

NUOVA COLLEZIONE
NEW COLLECTION

UPDATE 2022

FontanaArte

MILANO 1932

NUOVA COLLEZIONE /
NEW COLLECTION 2022

4 **FRENESI**

StudioLucaGuadagnino

8 - PARETE / WALL

10 - StudioLucaGuadagnino

12 **THEA**

Gabriele e Oscar Buratti

14 - TAVOLO / TABLE

18 - TERRA / FLOOR

20 - PARETE / WALL

24 - SOSPENSIONE / SUSPENSION

28 - Gabriele e Oscar Buratti

30 **TUTTI**

Matilde Cassani

34 - SOSPENSIONE / SUSPENSION

40 - Matilde Cassani

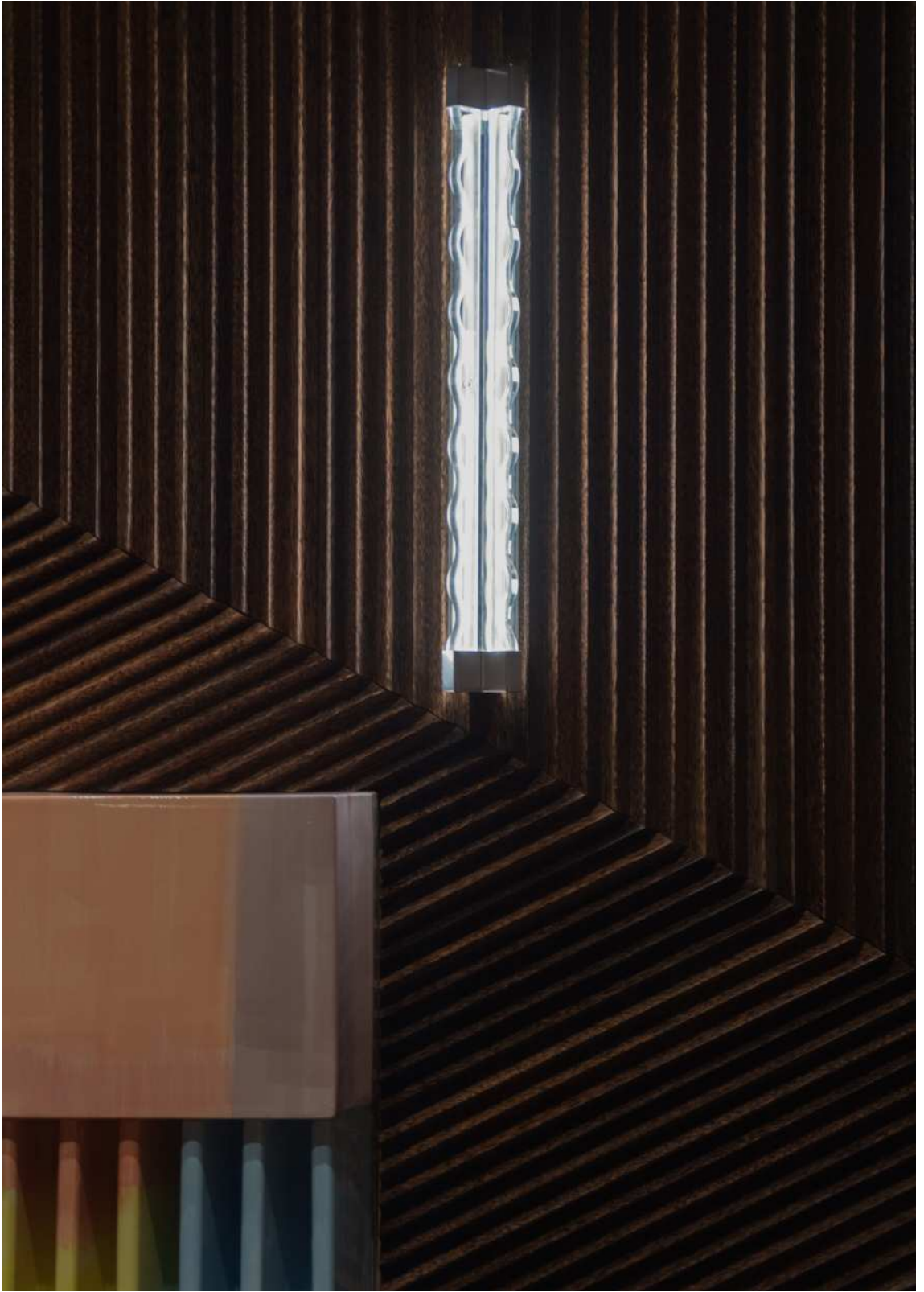

The *FRENESI* lamp comes from the author's passion – filmmaker Luca Guadagnino – for art deco, a style he loves in all its declinations, particularly for the angularity, the design, the regular shapes of the lines that meet and intersect. Today, the FontanaArte collection is still a synthesis of art deco, which, in an Italian key, illuminates homes all over the world. The designer questioned the form to which he should strive in order to create an object that respected the stylistic expression of the era from which it was inspired but with a contemporary language.

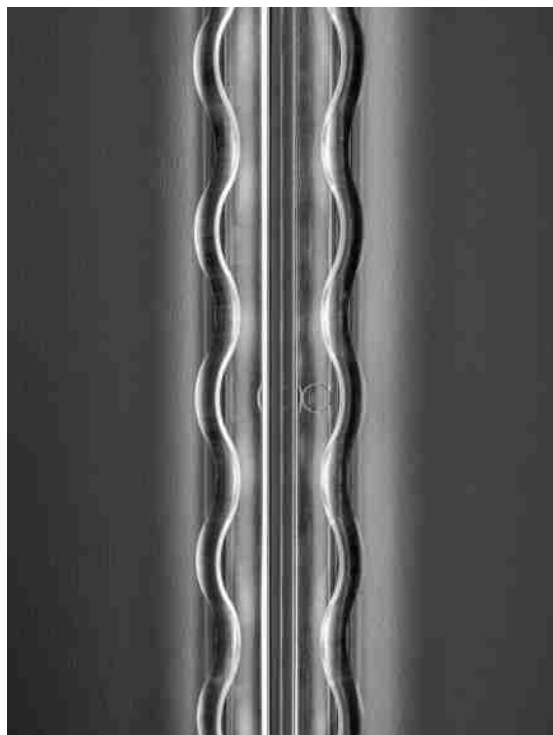

La lampada *FRENESI* nasce dalla passione dell'autore – il cineasta Luca Guadagnino – per l'art déco, stile amato in tutte le sue declinazioni, in particolare per l'angolarità, per il disegno, le forme regolari delle linee che si incontrano e incrociano. La collezione FontanaArte è tutt'oggi una sintesi di art déco che, in chiave italiana, illumina le case in tutto il mondo. L'autore si è interrogato sulla forma alla quale tendere per creare un oggetto che rispettasse l'espressione stilistica dell'epoca a cui si ispira ma con un linguaggio contemporaneo.

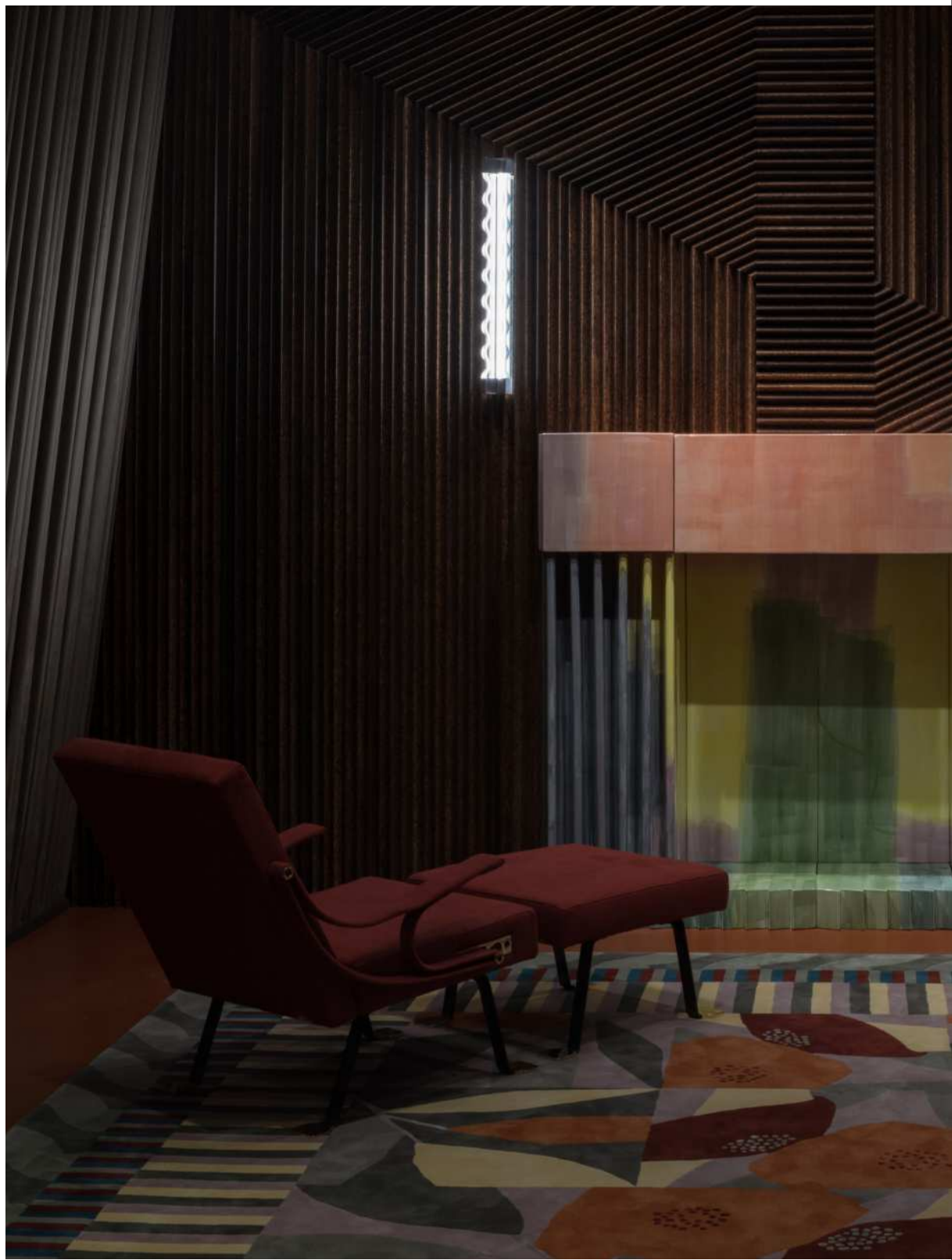



Nasce così Frenesi, dal nome della protagonista del romanzo *Vineland* dello scrittore statunitense Thomas Pynchon, ispirata all'idea dell'onda, una sensuale increspatura, realizzata nel materiale più puro e sostenibile come il vetro, che emana una luce morbida all'interno della struttura angolare.

This is how Frenesi was born, named after the protagonist of the novel *Vineland* by the American writer Thomas Pynchon, inspired by the idea of the wave, a sensual ripple, made of the purest and most sustainable material such as glass, which emanates a soft light within the angular structure.

Lampada da parete a luce diffusa dimmerabile. Diffusore in vetro in lastra tagliato, molato e lucidato. Spessore 2 cm in colore extra chiaro. Montatura in metallo cromato galvanizzato. Led integrato.

Wall lamp providing diffuse dimmable light. Sheet glass diffuser cut, ground and polished. 2 cm. thick in extra-clear colour. The frame is galvanised chrome-plated metal. LED integrated.



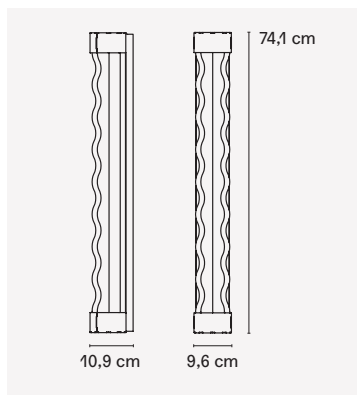

Codice Code	F446745550TCLE
Materiale Material	Vetro, Metallo Glass, Metal
Colore Color	Trasparente, Cromo Transparent, Chrome
Sorgente luminosa Light source	LED 2x7W (2700K, CRI>90, 1550Lm)
Dimmarabile Dimmable	Sì, a taglio di fase Yes, phase cut dimmer
Classe energetica Energy label	F

CE IP40

Studio Luca Guadagnino è uno studio di architettura d'interni con sede a Milano fondato dal regista Luca Guadagnino candidato premio Oscar nel 2017 e specializzato nel design contemporaneo mid-century italiano. Lo studio si occupa di progetti privati commissionati da clienti come Federico Marchetti, fondatore del gruppo Yoox Net-a-Porter e di progetti di retail per marchi del lusso tra i quali i nuovi negozi per il brand di skincare Aesop a Roma e a Londra e Redemption, brand di moda sostenibile, a New York. SLG è stato pubblicato su "By Design: The World's Best Contemporary Designers, un'autorevole guida che ha selezionato 100 tra i migliori e più creativi interior designers di oggi, edito da Phaidon nel 2021.

Studio Luca Guadagnino is a Milan-based interior architecture studio founded by 2017 Oscarnominated director Luca Guadagnino and specialising in contemporary mid-century Italian design. The studio handles private projects commissioned by clients such as Federico Marchetti, founder of the Yoox Net-a-Porter group, and retail projects for luxury brands including new shops for skincare brand Aesop in Rome and London and Redemption, a sustainable fashion brand, in New York. SLG was featured in By Design: The World's Best Contemporary Designers, an authoritative guide that selected 100 of today's best and most creative interior designers, published by Phaidon in 2021.

“FontanaArte is a magnificence of Made in Italy and represents Italian cosmopolitanism. Artists from all over the world have created unforgettable pieces over the years. A contamination of ideas, cultures, and visions, a set of identities that have resulted in all-Italian craftsmanship and savoir faire, which have created a collection of lamps that are part of design history. Designing alongside FontanaArte is a great wish come true and fills the entire studiolumacagnino with pride; I hope it is the beginning of a long-lasting collaboration.”

Luca Guadagnino

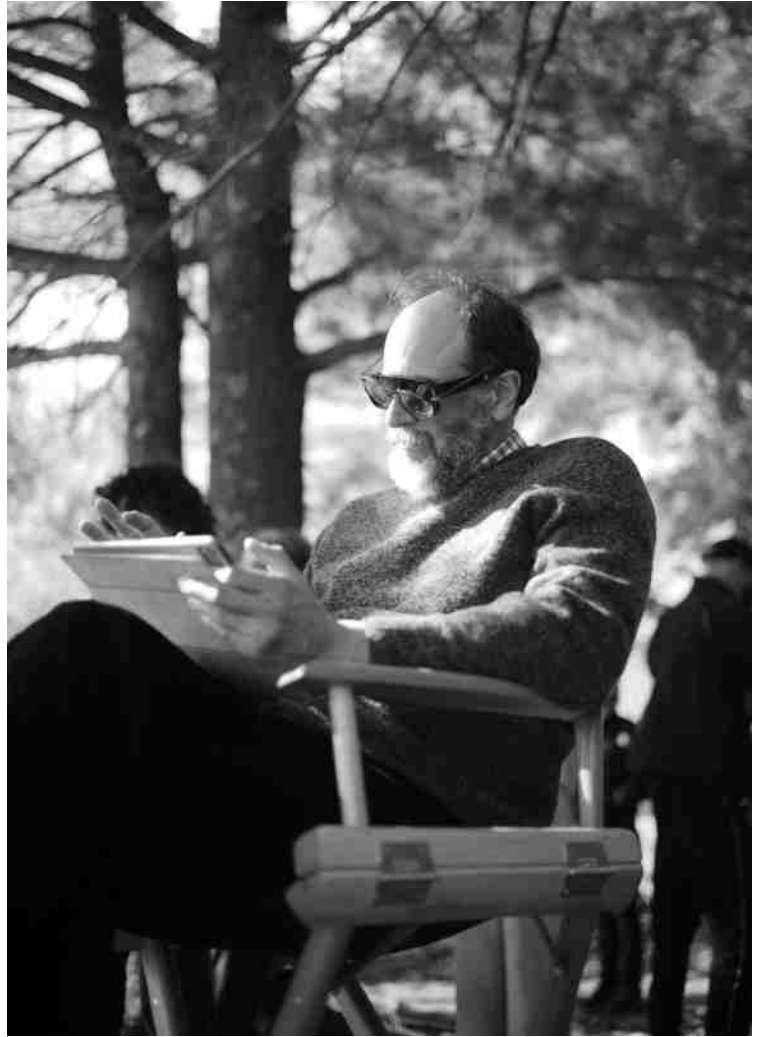

“FontanaArte è una magnificenza del Made in Italy e rappresenta il cosmopolitismo italiano. Artisti di tutto il mondo, negli anni, hanno creato pezzi indimenticabili. Una contaminazione di idee, culture e visioni, un insieme di identità sfociate nell’artigianalità e savoir faire tutto italiano, che hanno dato vita ad una collezione di lampade che fanno parte della storia del design. Progettare al fianco di FontanaArte è un grande desiderio che si avvera e riempie di orgoglio l’intero studiolumacagnino; spero sia l’inizio di una lunga collaborazione.”

Luca Guadagnino



The relationship between light and glass continues in Gabriele and Oscar Buratti's research which started with the Equatore lamp and has now culminated in the new *THEA* lamp collection, also designed for FontanaArte. *The magic of the reflections* that light gives off when it comes into contact with curved glass surfaces is the essential character of the lamp, thanks to its double diffuser: the first is small and internal, in white opaline glass, which has the function of diffusing the light homogeneously; the second diffuser, transparent or coloured, collects the light and multiplies it inside.



Continua il percorso di ricerca di Gabriele e Oscar Buratti sul tema del rapporto tra luce e vetro, iniziato con la lampada Equatore ed oggi approdato alla nuova collezione di lampade *THEA*, anche questa disegnata per FontanaArte.

La magia dei riflessi che la luce sprigiona al contatto con le superfici curve in vetro è il carattere essenziale della lampada, grazie alla doppia calotta: la prima piccola e interna, in vetro opalino bianco, che ha la funzione di diffondere la luce in modo omogeneo; la seconda calotta, trasparente o colorata, raccoglie la luce e la moltiplica al suo interno.

THEA

Tavolo, terra, parete, soffitto e sospensione, THEA è una famiglia di lampade trasversale alle tipologie di applicazione, pensata per un utilizzo sia negli ambienti domestici della casa che negli spazi più pubblici e contract dell'hotellerie, della ristorazione e del lavoro.

Table, floor, wall, ceiling and pendant, THEA is a family of lamps that covers all types of applications, designed for use both in the domestic environment of the home and in the more public and contract spaces of the hotel, restaurant and work sectors.







Lampada da tavolo a luce diffusa dimmerabile. Struttura in metallo galvanizzato. Diffusore interno in vetro soffiato bianco opalino acidato, diffusore esterno disponibile in vetro trasparente o colorato. Cavo di alimentazione, dimmer e spina neri. Alimentatore su spina con plug intercambiabili (UK, USA, Europa, Cina). Led integrato. La lampada mantiene memoria dell'ultima impostazione di dimmerazione.

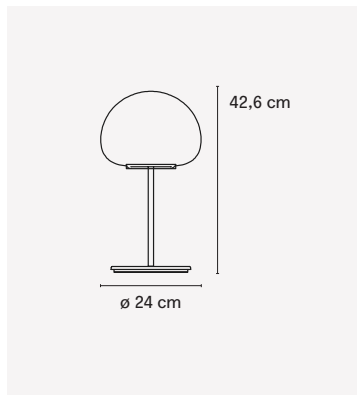

Table lamp providing diffuse dimmable light. Structure in galvanised metal. Inner diffuser in opal white blown acid-etched glass, outer diffuser available in transparent or coloured glass. Black power cable, dimmer and plug. Power supply on interchangeable plugs (UK, USA, Europe, China). Integrated LED. The lamps keeps memory of last dimming setting.

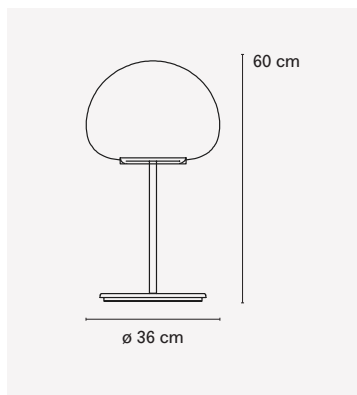

Codice Code	F444905550NFWL
Materiale Material	Vetro, Metallo Galvanizzato Glass, Galvanized Metal
Colore Color	Nero lucido, Fumè Glossy black, Grey fumè
Sorgente luminosa Light source	LED 3,85W (3000K, CRI>90, 640Lm)
Dimmer incluso Dimmer included	Si Yes
Classe energetica Energy label	F
	 <small>Classe III</small> IP20

Codice Code	F444905575RTWL
Materiale Material	Vetro, Metallo Galvanizzato Glass, Galvanized Metal
Colore Color	Rame lucido, Trasparente Glossy copper, Transparent
Sorgente luminosa Light source	LED 3,85W (3000K, CRI>90, 640Lm)
Dimmer incluso Dimmer included	Si Yes
Classe energetica Energy label	F
	 <small>Classe III</small> IP20



Codice Code	F444910550NFWL
Materiale Material	Vetro, Metallo Galvanizzato Glass, Galvanized Metal
Colore Color	Nero lucido, Fumè Glossy black, Grey fumè
Sorgente luminosa Light source	LED 11,6W (3000K, CRI>90, 1596Lm)
Dimmer incluso Dimmer included	Si Yes
Classe energetica Energy label	F
 VETRO SOFFIATO BLOWN GLASS	 ^{Classe III} IP20

Codice Code	F444910575RTWL
Materiale Material	Vetro, Metallo Galvanizzato Glass, Galvanized Metal
Colore Color	Rame lucido, Trasparente Glossy copper, Transparent
Sorgente luminosa Light source	LED 11,6W (3000K, CRI>90, 1596Lm)
Dimmer incluso Dimmer included	Si Yes
Classe energetica Energy label	F
 VETRO SOFFIATO BLOWN GLASS	 ^{Classe III} IP20



Lampada da terra a luce diffusa dimmerabile. Struttura in metallo galvanizzato. Diffusore interno in vetro soffiato bianco opalino acidato, diffusore esterno disponibile in vetro trasparente o colorato. Cavo di alimentazione, dimmer e spina neri. Alimentatore su spina con plug intercambiabili (UK, USA, Europa, Cina). Led integrato. La lampada mantiene memoria dell'ultima impostazione di dimmerazione. È possibile richiedere versione con Casambi integrato.

Floor lamp providing diffuse dimmable light. Structure in galvanised metal. Inner diffuser in opal white blown acid-etched glass, outer diffuser available in transparent or coloured glass. Black power cable, dimmer and plug. Power supply on interchangeable plugs (UK, USA, Europe, China). Integrated LED. The lamps keeps memory of last dimming setting. The product with integrated Casambi control system available on request.

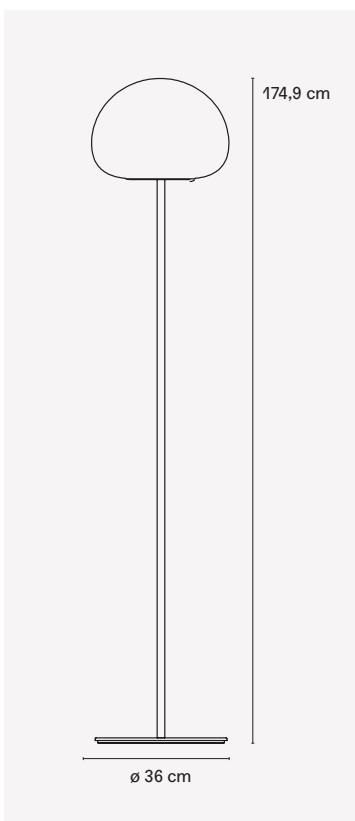

Codice Code	F444930550NFWL
Materiale Material	Vetro, Metallo Galvanizzato Glass, Galvanized Metal
Colore Color	Nero lucido, Fumè Glossy black, Grey fumè
Sorgente luminosa Light source	LED 11,6W (3000K, CRI>90, 1596Lm)
Dimmer incluso Dimmer included	Si Yes
Classe energetica Energy label	F
 VETRO SOFFIATO BLOWN GLASS	 ^{Classe III} IP20

Codice Code	F444930575RTWL
Materiale Material	Vetro, Metallo Galvanizzato Glass, Galvanized Metal
Colore Color	Rame lucido, Trasparente Glossy copper, Transparent
Sorgente luminosa Light source	LED 11,6W (3000K, CRI>90, 1596Lm)
Dimmer incluso Dimmer included	Si Yes
Classe energetica Energy label	F
 VETRO SOFFIATO BLOWN GLASS	 ^{Classe III} IP20

Lampada da parete/plafone a luce diffusa dimmerabile. Montatura in metallo verniciato. Diffusore interno in vetro soffiato bianco opalino acidato, diffusore esterno disponibile in vetro trasparente o colorato. Led integrato.

Wall/ceiling lamp providing diffuse dimmable light. Painted metal frame. Inner diffuser in opal white blown acid-etched glass, outer diffuser available in transparent or coloured glass. Integrated LED.



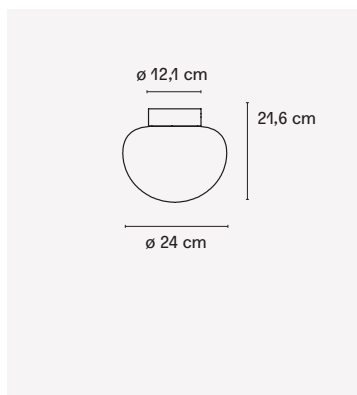

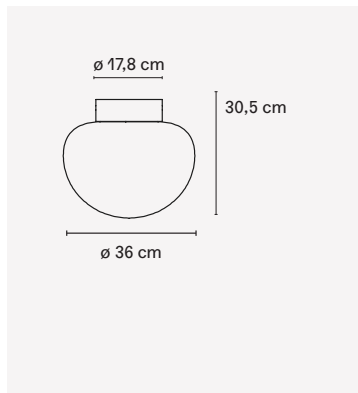

Codice Code	F444965550NFLE
Materiale Material	Vetro, Metallo Galvanizzato Glass, Galvanized Metal
Colore Color	Nero lucido, Fumè Glossy black, Grey fumè
Sorgente luminosa Light source	LED 3,85W (3000K, CRI>90, 640Lm)
Dimmerabile Dimmable	Si, TRIAC Yes, TRIAC
Classe energetica Energy label	F
 IP40	

Codice Code	F4449655575RTLE
Materiale Material	Vetro, Metallo Galvanizzato Glass, Galvanized Metal
Colore Color	Rame lucido, Trasparente Glossy copper, Transparent
Sorgente luminosa Light source	LED 3,85W (3000K, CRI>90, 640Lm)
Dimmerabile Dimmable	Si, TRIAC Yes, TRIAC
Classe energetica Energy label	F
 IP40	



Codice Code	F444970550NFLE
Materiale Material	Vetro, Metallo Galvanizzato Glass, Galvanized Metal
Colore Color	Nero lucido, Fumè Glossy black, Grey fumè
Sorgente luminosa Light source	LED 11,6W (3000K, CRI>90, 1596Lm)
Dimmerabile Dimmable	Si, 1-10V / PUSH Yes, 1-10V / PUSH
Classe energetica Energy label	F
	 IP40

Codice Code	F444970575RTLLE
Materiale Material	Vetro, Metallo Galvanizzato Glass, Galvanized Metal
Colore Color	Rame lucido, Trasparente Glossy copper, Transparent
Sorgente luminosa Light source	LED 11,6W (3000K, CRI>90, 1596Lm)
Dimmerabile Dimmable	Si, 1-10V / PUSH Yes, 1-10V / PUSH
Classe energetica Energy label	F
	 IP40





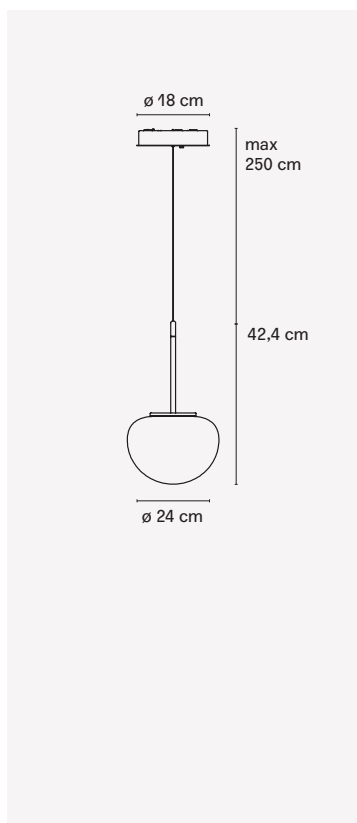

Lampada a sospensione a luce diffusa dimmerabile. Montatura in metallo galvanizzato. Diffusore interno in vetro soffiato bianco opalino acidato, diffusore esterno diponibile in vetro trasparente o colorato. Cavo di sospensione in acciaio. Cavo di alimentazione nero. Rosone in metallo verniciato bianco. Led integrato.

Pendant lamp providing diffused dimmable light. Galvanised metal frame. Inner diffuser in opal white blown acid-etched glass, outer diffuser in available in transparent or coloured glass. Steel suspension cable. Black power cable. Metal ceiling rose painted white. Integrated LED



Codice Code	F444985550NFLE
Materiale Material	Vetro, Metallo Galvanizzato Glass, Galvanized Metal
Colore Color	Nero lucido, Fumè Glossy black, Grey fumè
Sorgente luminosa Light source	LED 3,85W (3000K, CRI>90, 640Lm))
Dimmerabile Dimmable	Si, TRIAC Yes, TRIAC
Classe energetica Energy label	F
 VETRO SOFFIATO BLOWN GLASS	CE IP40

Codice Code	F444985575RTLE
Materiale Material	Vetro, Metallo Galvanizzato Glass, Galvanized Metal
Colore Color	Rame lucido, Trasparente Glossy copper, Transparent
Sorgente luminosa Light source	LED 3,85W (3000K, CRI>90, 640Lm))
Dimmerabile Dimmable	Si, TRIAC Yes, TRIAC
Classe energetica Energy label	F
 VETRO SOFFIATO BLOWN GLASS	CE IP40

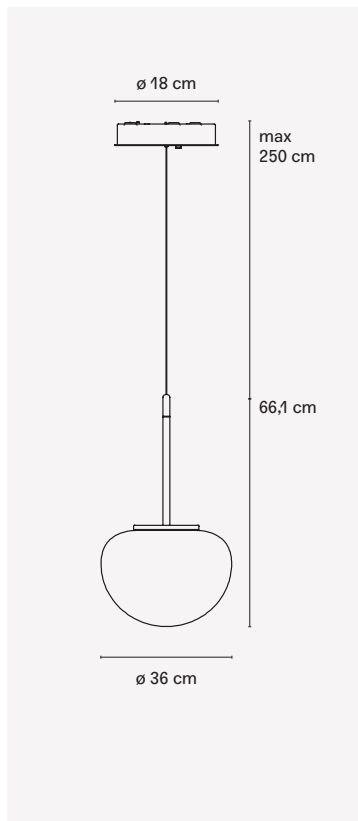

Codice Code	F444990550NFLE
Materiale Material	Vetro, Metallo Galvanizzato Glass, Galvanized Metal
Colore Color	Nero lucido, Fumè Glossy black, Grey fumè
Sorgente luminosa Light source	LED 11,6W (3000K, CRI>90, 1596Lm)
Dimmerabile Dimmable	Si, 1-10V / PUSH Yes, 1-10V / PUSH
Classe energetica Energy label	F



CE IP40

Codice Code	F444990575RTLE
Materiale Material	Vetro, Metallo Galvanizzato Glass, Galvanized Metal
Colore Color	Rame lucido, Trasparente Glossy copper, Transparent
Sorgente luminosa Light source	LED 3,85W (3000K, CRI>90, 640Lm))
Dimmerabile Dimmable	Si, 1-10V / PUSH Yes, 1-10V / PUSH
Classe energetica Energy label	F



CE IP40



Gabriele Buratti, architetto e professore di architettura degli interni alla Facoltà del Design del Politecnico di Milano (2003-2010), e Oscar Buratti, architetto, formano lo studio di architettura e design Buratti Architetti. Diverse sono le scale del progetto su cui lo studio lavora in maniera trasversale, passando dall'architettura di edifici ed aree urbane a quella degli interni, dal design di mobili ed oggetti all'allestimento di mostre e showroom, in un percorso professionale intenso e variegato, dove si intrecciano, contaminandosi, i temi, i luoghi e le tipologie, le aziende e le persone, i materiali e le lavorazioni. Progettano edifici residenziali, commerciali ed industriali, interventi in centri storici e ristrutturazioni di complessi edilizi, ville ed interni di uffici, abitazioni, negozi e showroom, con l'intento di coniugare cultura e specializzazione professionale, sperimentazione e tecnica, visioni originali e qualità del prodotto. Nel settore del retail collaborano con brand prestigiosi per i quali realizzano boutique nelle più importanti città del mondo. Collaborano con alcune fra le più prestigiose e rinomate aziende del design per le quali hanno firmato progetti dell'illuminazione e dell'arredo venduti in tutto il mondo.

Gabriele Buratti, architect and professor of interior architecture at the Faculty of Design of Politecnico of Milan (2003-2010), e Oscar Buratti, architect, form the architecture and design studio Buratti Architetti. There are several scales of the project on which the studio works, from the architecture of buildings and urban areas to the interior of buildings, from the design of furniture and objects to exhibitions and showrooms, in an intense and varied professional path, where themes, places and typologies, companies and people, materials and workmanship, are intertwined and contaminating. They design residential, commercial and industrial buildings, interventions in historic centers and renovations of complex buildings, villas and interiors of offices, dwellings, shops and showrooms, with the aim of combining culture and professional specialization, experimentation and technique, original visions and product quality. In the retail field they collaborated with prestigious brands for which they created boutiques in the most important cities around the world. They collaborate with some of the most prestigious and renowned design companies for which they have signed lighting and furniture projects that are sold all over the world.

“A product with a refined and timeless taste, shapes with a refined design that reinterpret some classic canons and typical characters of our design, projecting them into a context of contemporary signs.”

Gabriele e Oscar Buratti

“Un prodotto con un gusto raffinato e senza tempo, forme dal disegno ricercato che reinterpretano alcuni canoni classici e caratteri tipici del nostro design, proiettandoli in un contesto di segni contemporanei.”

Gabriele e Oscar Buratti





TUTTI designed by artist and designer Matilde Cassani for FontanaArte, tells a very topical story of contamination, of the union of similar yet opposite elements, of changing identities, of tastes and thoughts apparently opposed but belonging to the same individual; of peoples and cultures that mingle and become a single social nucleus, different in origin but united and for this reason extraordinary.



TUTTI disegnata per FontanaArte dall'artista e progettista Matilde Cassani, racconta una storia molto attuale di contaminazione, di unione fra elementi simili anche se opposti, di identità mutevoli, di gusti e pensieri apparentemente contrapposti ma che appartengono allo stesso individuo; di popoli e culture che si mischiano e diventano un unico nucleo sociale, diverso dalle origini ma unito e per questo straordinario.





Tutti è il trionfo degli opposti rappresentato da una serie di sagome appese che simboleggiano un mondo di contraddizioni e contrapposizioni: drappo religioso assieme allo scudetto della squadra di calcio; uomo e/o donna: gender fluidity; gonna e pantaloni; bottiglietta in plastica e pesce. Per citarne alcuni.

Tutti is the triumph of opposites represented by a series of hanging silhouettes symbolising a world of contradictions and contrasts: religious drape together with football team badge; man and/or woman: gender fluidity; skirt and trousers; plastic bottle and fish, to name a few.

Lampada a sospensione a luce diretta. L'effetto riflettente sugli elementi decorativi genera la diffusione della luce nell'ambiente circostante. Rosone in metallo verniciato. Elementi decorativi in metallo galvanizzato dello stesso colore del cavo di sospensione. Led integrato.

Pendant lamp providing direct light. The reflective effect on the decorative elements generates the diffusion of the light in the room. Painted metal ceiling rose. Galvanised metal decorative elements in the same colour as the suspension cable. Integrated LED.

Mela / Pera - Apple / Pear

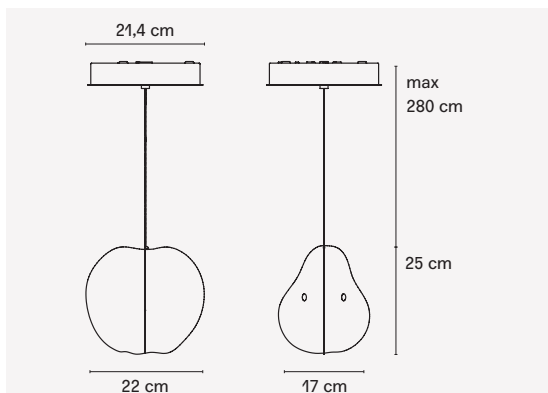

Codice Code	F446880240CRLE
Materiale Material	Metallo Metal
Colore Color	Cromo Chrome
Sorgente luminosa Light source	12W LED (3000K, CRI>90, 1470Lm)
Dimmerabile Dimmable	Si, TRIAC Yes, TRIAC
Classe energetica Energy label	F

Codice Code	F446880240OOLE
Materiale Material	Metallo Metal
Colore Color	Oro Gold
Sorgente luminosa Light source	12W LED (3000K, CRI>90, 1470Lm)
Dimmerabile Dimmable	Si, TRIAC Yes, TRIAC
Classe energetica Energy label	F

Mano aperta / Mano chiusa - Hand open / Hand close

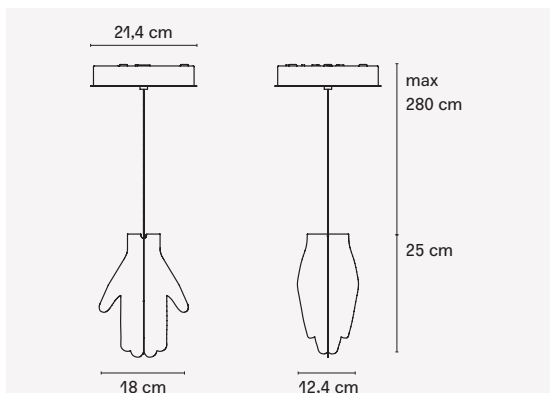

Codice Code	F446980240CRLE
Materiale Material	Metallo Metal
Colore Color	Cromo Chrome
Sorgente luminosa Light source	12W LED (3000K, CRI>90, 1470Lm)
Dimmerabile Dimmable	Si, TRIAC Yes, TRIAC
Classe energetica Energy label	F

Codice Code	F446980240OOLE
Materiale Material	Metallo Metal
Colore Color	Oro Gold
Sorgente luminosa Light source	12W LED (3000K, CRI>90, 1470Lm)
Dimmerabile Dimmable	Si, TRIAC Yes, TRIAC
Classe energetica Energy label	F

Uomo / Donna - Man / Woman

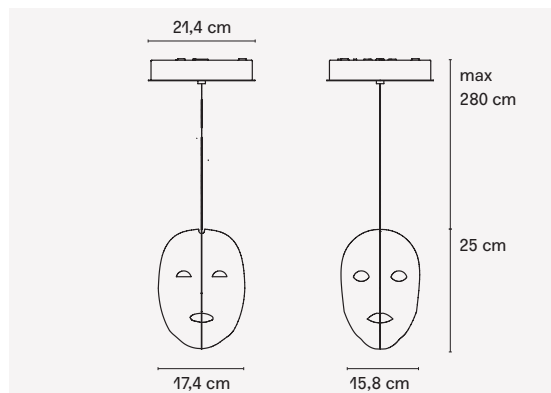

Codice Code	F447080240CRLE
Materiale Material	Metallo Metal
Colore Color	Cromo Chrome
Sorgente luminosa Light source	12W LED (3000K, CRI>90, 1470Lm)
Dimmerabile Dimmable	Si, TRIAC Yes, TRIAC
Classe energetica Energy label	F

Codice Code	F447080240OOLE
Materiale Material	Metallo Metal
Colore Color	Oro Gold
Sorgente luminosa Light source	12W LED (3000K, CRI>90, 1470Lm)
Dimmerabile Dimmable	Si, TRIAC Yes, TRIAC
Classe energetica Energy label	F

Bottiglia / Pesce - Bottle / Fish

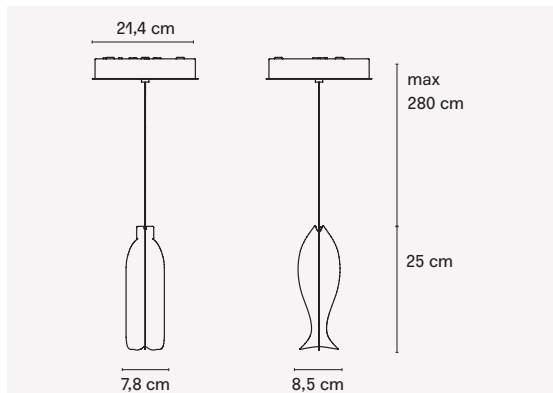

Codice Code	F447180240CRLE
Materiale Material	Metallo Metal
Colore Color	Cromo Chrome
Sorgente luminosa Light source	12W LED (3000K, CRI>90, 1470Lm)
Dimmerabile Dimmable	Si, TRIAC Yes, TRIAC
Classe energetica Energy label	F

Codice Code	F447180240OOLE
Materiale Material	Metallo Metal
Colore Color	Oro Gold
Sorgente luminosa Light source	12W LED (3000K, CRI>90, 1470Lm)
Dimmerabile Dimmable	Si, TRIAC Yes, TRIAC
Classe energetica Energy label	F

Foglie / Leaves

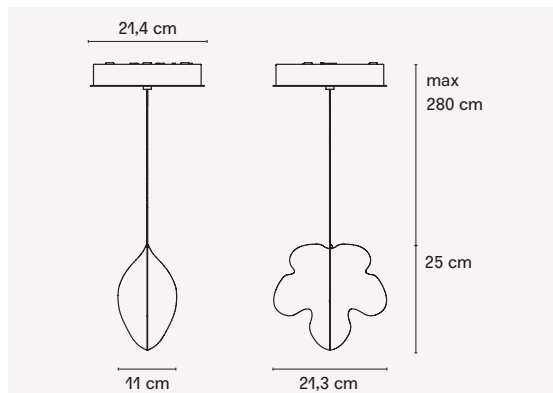

Codice Code	F447280240CRLE
Materiale Material	Metallo Metal
Colore Color	Cromo Chrome
Sorgente luminosa Light source	12W LED (3000K, CRI>90, 1470Lm)
Dimmerabile Dimmable	Si, TRIAC Yes, TRIAC
Classe energetica Energy label	F

Codice Code	F447280240OOLE
Materiale Material	Metallo Metal
Colore Color	Oro Gold
Sorgente luminosa Light source	12W LED (3000K, CRI>90, 1470Lm)
Dimmerabile Dimmable	Si, TRIAC Yes, TRIAC
Classe energetica Energy label	F

Sasso / Diamante - Stone / Diamond

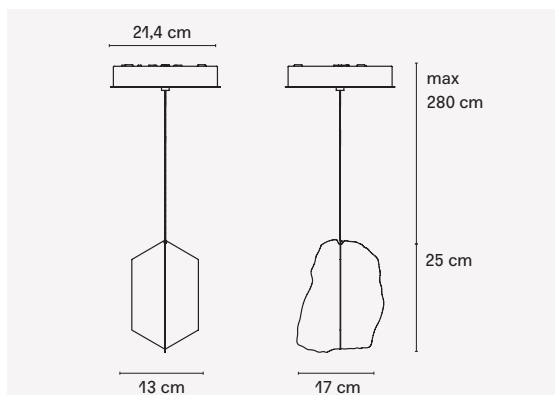

Codice Code	F447380240CRLE
Materiale Material	Metallo Metal
Colore Color	Cromo Chrome
Sorgente luminosa Light source	12W LED (3000K, CRI>90, 1470Lm)
Dimmerabile Dimmable	Si, TRIAC Yes, TRIAC
Classe energetica Energy label	F
CE IP20	

Codice Code	F447380240OOLE
Materiale Material	Metallo Metal
Colore Color	Oro Gold
Sorgente luminosa Light source	12W LED (3000K, CRI>90, 1470Lm)
Dimmerabile Dimmable	Si, TRIAC Yes, TRIAC
Classe energetica Energy label	F
CE IP20	

Drappo / Scudetto - Drape / Badge

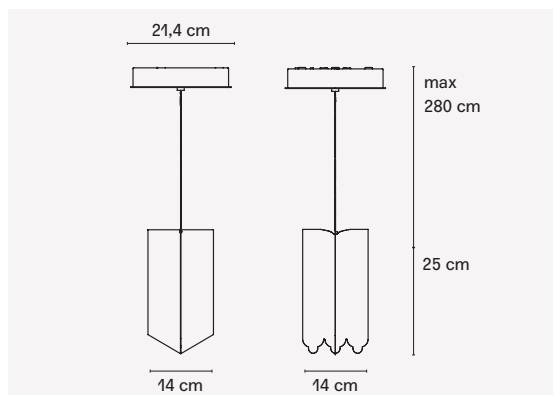

Codice Code	F447480240CRLE
Materiale Material	Metallo Metal
Colore Color	Cromo Chrome
Sorgente luminosa Light source	12W LED (3000K, CRI>90, 1470Lm)
Dimmerabile Dimmable	Si, TRIAC Yes, TRIAC
Classe energetica Energy label	F
CE IP20	

Codice Code	F447480240OOLE
Materiale Material	Metallo Metal
Colore Color	Oro Gold
Sorgente luminosa Light source	12W LED (3000K, CRI>90, 1470Lm)
Dimmerabile Dimmable	Si, TRIAC Yes, TRIAC
Classe energetica Energy label	F
CE IP20	

Gonna / Pantaloni - Skirt / Trousers

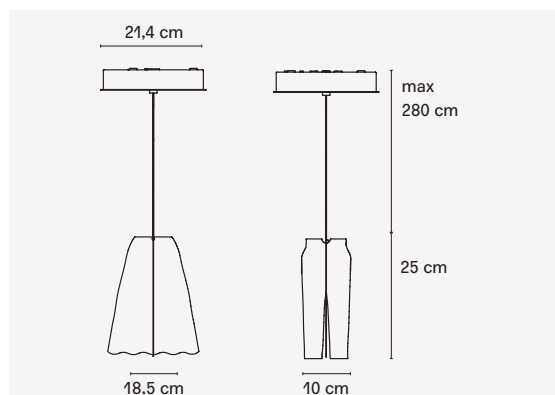

Codice Code	F447580240CRLE
Materiale Material	Metallo Metal
Colore Color	Cromo Chrome
Sorgente luminosa Light source	12W LED (3000K, CRI>90, 1470Lm)
Dimmerabile Dimmable	Si, TRIAC Yes, TRIAC
Classe energetica Energy label	F



Codice Code	F447580240OOLE
Materiale Material	Metallo Metal
Colore Color	Oro Gold
Sorgente luminosa Light source	12W LED (3000K, CRI>90, 1470Lm)
Dimmerabile Dimmable	Si, TRIAC Yes, TRIAC
Classe energetica Energy label	F



Lampada a sospensione multipla a luce diretta.

L'effetto riflettente sugli elementi decorativi genera la diffusione della luce nell'ambiente circostante. Rosone in metallo verniciato nero. Elementi decorativi in metallo galvanizzato dello stesso colore del cavo di sospensione. Led integrato.

Multiple pendant lamp providing direct light. The reflective effect on the decorative elements generates the diffusion of the light in the room. Black painted metal ceiling rose.

Galvanised metal decorative elements in the same colour as the suspension cable. Integrated LED.

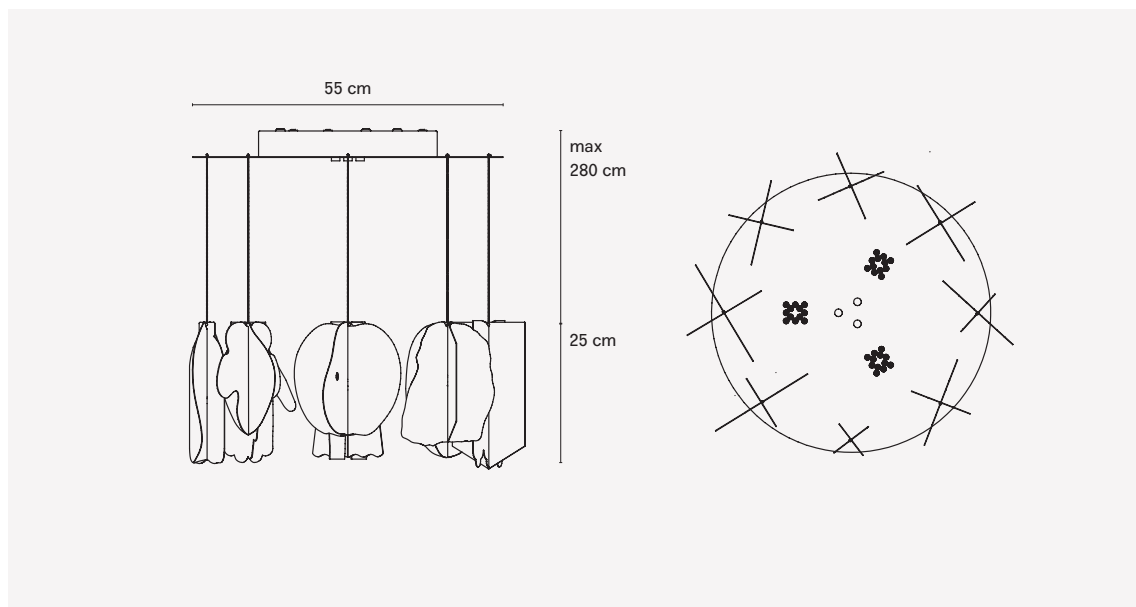

Codice Code	F446890240CRLE
Materiale Material	Metallo Metal
Colore Color	Cromo Chrome
Sorgente luminosa Light source	3x12W LED (3000K, CRI>90, 4410Lm)
Dimmerabile Dimmable	Si, TRIAC Yes, TRIAC
Classe energetica Energy label	F

CE IP20

Codice Code	F446890240OOLE
Materiale Material	Metallo Metal
Colore Color	Oro Gold
Sorgente luminosa Light source	3x12W LED (3000K, CRI>90, 4410Lm)
Dimmerabile Dimmable	Si, TRIAC Yes, TRIAC
Classe energetica Energy label	F

CE IP20

Matilde Cassani si muove in un'area di confine fra architettura, installazioni, ed event design. Il suo lavoro trova la propria origine nelle implicazioni spaziali del pluralismo culturale. I suoi lavori sono stati esposti in molte istituzioni e manifestazioni fra cui lo Storefront for Art and Architecture di New York (2011); tre edizioni della Biennale Architettura di Venezia (2012, 2014, 2018); Victoria and Albert Museum (2015); Triennale di Oslo (2016); Biennale di Architettura di Chicago (2017); Manifesta 12 (2018); Triennale di Milano (2019); Cassani ha insegnato in diverse università europee fra cui il Sandberg Instituut di Amsterdam, la Syracuse Architecture University di Firenze. Attualmente insegna alla NABA di Milano e alla AA, Architectural Association di Londra. Sue opere sono presenti nelle collezioni di diversi musei fra cui il Victoria and Albert Museum, il MAXXI e il Franz Hals Museum di Harleem.

Matilde Cassani moves on the border between architecture, installation and event design. Her practice deals with the spatial implications of cultural pluralism in the contemporary Western city. Her works have been exhibited in many institutions such as Storefront for Art and Architecture, New York (2011); Biennale Architettura di Venezia (2012, 2014, 2018); Victoria and Albert Museum (2015); Oslo Triennale (2016); Chicago Architecture Biennale (2017); Manifesta 12, Palermo (2018); Triennale di Milano (2019); She currently teaches at Naba in Milano and at the Architectural Association in London. Her works are present in several museum collections including Victoria and Albert Museum, il MAXXI e il Franz Hals Museum di Harleem.

“I observe people who at any given moment find themselves sharing, even accidentally, the same space, the same underground, the same station. They all represent the diversity of individuals: religious orientations, sporting passions, cultural and gender inclinations. It is an ark that contains everything that man, at this moment, would carry into the future. Its elements are the ex-votos of today. They revolve around themselves, showing their opposite.”

Matilde Cassani



“Osservo le persone che in un momento qualsiasi si trovano a condividere, anche accidentalmente, lo stesso spazio, la stessa metropolitana, la stessa stazione. Tutti rappresenta la diversità degli individui: gli orientamenti religiosi, le passioni sportive, le inclinazioni culturali e di genere. È un’arca che contiene tutto ciò che l’uomo, in questo momento, porterebbe nel futuro. I suoi elementi sono gli ex voto di oggi. Ruotano su sé stessi, mostrando il loro opposto.”

Matilde Cassani

