

LUMEN
CENTER
ITALIA



MADE IN ITALY

LUMEN CENTER ITALIA

THE EXCELLENCE OF LIGHTING DESIGN SINCE 1976



Dal 1976 LUMEN CENTER ITALIA è un grande laboratorio di ricerca, design e produzione di apparecchi per l'illuminazione.

La sua vocazione per il design contemporaneo ed il suo orientamento verso i mercati internazionali hanno origini lontane: l'azienda nasce, infatti, come LUMEN CENTER FRANCE a La Fare-les-Oliviers, con la collezione di lampade di importanti designer francesi, diviene LUMEN CENTER ITALIA, rafforza il proprio *core business*, cresce e si espande fino all'estremo Oriente con la nuova nata LUMEN CENTER JAPAN.

Da sempre attenta alla qualità, LCI è un luogo dove si indaga la relazione fra l'uomo e la luce, dove si sperimentano tecnologie che attraverso un utilizzo innovativo delle fonti luminose possano migliorare la qualità della vita e accompagnare nel modo più confortevole i diversi momenti della quotidianità, dal relax al lavoro, dalla fruizione culturale al convivio e al cibo.

Tra gli ultimi importanti progetti di ricerca, il progetto **luum®**, che offre sorgenti luminose LED attente all'interazione tra luce e metabolismo cellulare, con un'altissima resa cromatica e con uno spettro molto simile a quello della luce naturale.

Sono queste le sorgenti che LUMEN CENTER ITALIA ha scelto per illuminare la *food court* del padiglione Giappone ad Expo 2015 e la Veneranda Pinacoteca Ambrosiana di Milano, dove una luce di qualità LED esalta i dettagli e le cromie del cibo così come le opere di Leonardo Da Vinci, Tiziano, Raffaello, Bruegel e Botticelli.

Since 1976 LUMEN CENTER ITALIA is a big laboratory of research, design and production of light fittings. Its vocation for contemporary design and its international markets orientations has faraway origins: the company was born as LUMEN CENTER FRANCE in La Fare-les-Oliviers, with an important lighting collection of French designers. It becomes later LUMEN CENTER ITALIA strengthening its core business, growing and pushing itself up to the Far East with the newborn LUMEN CENTER JAPAN.

Always dedicated to quality, LUMEN CENTER ITALIA is a place where connections between man and light are studied, a place where new technologies are tested through an innovative use of light sources which improve quality of life and accompany different moments, from relaxing to work, from cultural enjoyment to food.

*In the latest research projects stands out **luum®**, which offers LED light sources attentive to the interactions between metabolism and light, with a very high colour rendering and a light source spectrum comparable to daylight.*

*LUMEN CENTER ITALIA has chosen **luum®** to light up Japan Pavilion food court at Expo 2015 and Veneranda Biblioteca Ambrosiana of Milan, where high-quality LED enhances details, warm colors and shades of food as well as Leonardo Da Vinci, Tiziano, Raffaello, Bruegel and Botticelli masterpieces.*

ルーメンセンター・イタリアは、1976年より照明機器の研究、デザイン、製造を一貫して行っている工房です。時流に沿ったデザインと国際市場に対する姿勢は、指標として創立当初より受け継がれております。

その誕生はルーメンセンター・フランスとしてラファール・レゾリヴィエール（フランス）に設立され、その当時から著名なフランス人デザイナーによる照明コレクションが数々と生み出されてきました。

その後、ルーメンセンター・イタリアとなり、そのコア・ビジネスを強化し、成長、拡大を続けることで新たにルーメンセンター・ジャパンを開設するまでに至りました。

ルーメンセンター・イタリアは、常日頃からその「品質」に重きを置きつつ、「人」と「光」の関係を研究し、革新的な光源のテクノロジーの追及も行っていきます。これによって、人々の生活向上と日常の様々な状況（リラックス、仕事、趣味行為、団らん、食事など）に適した『あかり』をお届けすることを目指しております。

数々の研究プロジェクトの中でも最も重要なものに「**luum®**」計画があげられます。

これは、光と人間の代謝の相互作用を考慮し、色彩再現力が非常に高く、光のスペクトルが自然光に最も近いLED光源を採用しています。

ルーメンセンター・イタリアは、ミラノ国際万博2015の日本館のフードコートと歴史あるアンブロジーアーナ絵画館のためにこのLED光源を導入しました。

これによって、食の空間から、レオナルド・ダヴィンチ、ティツィアーノ、ラファエロ、ブルーゲルやボッティチェリ達の作品といった芸術の世界まで、そのディテールと色彩の再現を可能と致しました。

LUMEN CENTER ITALIA

LIGHT, CREATIVITY, INNOVATION

Nasce nel 1976 a La-Fare-les-Oliviers in Francia sotto la direzione artistica di Gilles Derain, esponente di rilievo del design contemporaneo francese e tra i primi estimatori e studiosi dell'UAM - Union des Artistes Modernes - un movimento attivo tra il 1928 e il 1958, che confluì poi nel movimento moderno internazionale, e che vide tra i suoi fondatori artisti di spicco quali Eileen Gray, Charlotte Perriand, Jacques Adnet - di cui viene prodotta la lampada Quadro del 1929 - e Pierre Chareau, a cui viene dedicata la lampada MCP (Merci Chareau Pierre) che nel 1979 ebbe un grandissimo successo commerciale ed entrò a far parte della Collezione permanente del Museo di Belle Arti di Montreal.

Da sempre prodotti in Italia da una delle aziende di illuminazione del distretto milanese, i pezzi a catalogo, dell'allora francese Lumen Center, venivano commercializzati su territorio nazionale da LUMEN CENTER ITALIA, società italiana che qualche anno dopo rileva la società francese e diventa unica proprietaria e distributrice

sia a livello nazionale che internazionale. La consolidata collaborazione con i designer francesi tra cui Jean-Michel Wilmotte, autore della celebre lampada da tavolo Washington, e la ormai nota qualità dei prodotti offerti fanno sì che l'azienda, seppur di dimensioni ridotte e a conduzione familiare, acquisti sempre più quote di mercato consolidando la propria posizione nel panorama italiano ed internazionale dell'illuminazione.

È a fine anni Novanta che si prospetta una grande svolta, quando il DMC VillaTosca - coordinato e diretto da Augusto Grillo - entra in contatto con LUMEN CENTER ITALIA per la realizzazione del progetto di interior design e illuminazione del Royal Pines Hotel di Urawa in Giappone. Il progetto fu chiamato "Life River" e ancora oggi rappresenta l'altissima capacità tecnico-produttiva dell'azienda, nonché la capacità di realizzare con grande flessibilità progetti "tailor-made". L'avventura del DMC VillaTosca nel settore dell'illuminazione era però iniziata già nel 1993 in seguito ad un

programma di ricerca volto ad esplorare la luce colorata che confluì poi in un workshop sperimentale che si svolse nel suggestivo convento di Greccio e vide coinvolti numerosi studiosi e progettisti. Furono proprio i due progetti "Life River" ed "Heliopolis" che nel 2000 portarono il Gruppo VillaTosca ad acquisire LUMEN CENTER ITALIA.

Da allora, sono innumerevoli le iniziative portate avanti dall'azienda a livello internazionale; all'avanguardia le sperimentazioni sulle sinestesie tra luce, colore e suono, sull'utilizzo di sorgenti alternative come gli OLED o gli studi sull'interazione tra luce e metabolismo umano con l'avvio del progetto **luum**. Oggi LUMEN CENTER ITALIA vanta una filiale a Tokyo in Giappone con l'obiettivo di consolidare la sua presenza nei mercati dell'estremo Oriente, è stata sponsor dell'illuminazione della *food court* del Padiglione Giappone ad Expo 2015 e illumina le importanti opere di Leonardo Da Vinci, Tiziano, Raffaello, Bruegel e Botticelli presso la Veneranda Pinacoteca Ambrosiana di Milano.

Grounded in 1976 in La-Fare-les-Oliviers in France under the artistic direction of Gilles Derain, prominent exponent of the French contemporary design and one of the first admirers and researchers of UAM - Union des Artistes Modernes. This movement was active between 1928 and 1958, afterward it merged into the International Modern Movement and had among its founders prominent artists such as Eileen Gray, Charlotte Perriand, Jacques Adnet - whose table lamp Quadro designed in 1929 was produced by LCI - and Pierre Chareau to whom the lamp MCP was dedicated (Merci Pierre Chareau) which in 1979 had a huge commercial success and became part of the permanent collection of the Museum of Fine Arts in Montreal.

Since the beginning the lamps of the French Lumen Center catalogue have always been produced in Italy by a lighting manufacturer in the district of Milan and distributed on the national market by LUMEN CENTER ITALIA, an Italian company that a few years later took over the French company. It became

the sole owner and distributed the lamps on both the national and international markets. Thanks to the strict collaboration with French designers including Jean-Michel Wilmotte, designer of the famous table lamp Washington, and the long well known quality of the offered products, this company, albeit not big and family-run, has been gaining more and more market share consolidating its position in the Italian and international lighting sector.

In the late nineties a great turning point was close at hand, when the DMC Villa Tosca Design Management Centre - coordinated and directed by Augusto Grillo - came into contact with LUMEN CENTER ITALIA for the realization of the project of the interiors and lighting design of Urawa Royal Pines Hotel in Japan. The project was called "Life River" and still represents the company's very high technical-productive know-how and skill, as well as the ability to manage with great flexibility "tailor-made" projects. The adventure of DMC VillaTosca in the lighting industry, however, had its start in 1993 as

a result of a research program aimed at exploring the coloured light which then merged into an experimental workshop that took place in the striking convent of Greccio and saw many scholars, researchers and designers involved. It was these two projects "Life River" and "Heliopolis", that in 2000 led the Group VillaTosca to acquire LUMEN CENTER ITALIA.

*Since then, the company has made numerous innovations from being groundbreaking with studies on synesthesia (relations between light, colour and sound), to the use of alternative light sources as OLED or researches on the interactions between light and human metabolism with **luum** project. Nowadays LUMEN CENTER ITALIA claims another company in Tokyo (Japan) to consolidate its presence in Far East markets; indeed it has been technical sponsor of Japan Pavilion food court at Expo2015 and also lights up Leonardo Da Vinci, Tiziano, Raffaello, Bruegel and Botticelli masterpieces at Veneranda Pinacoteca Ambrosiana of Milan.*

1976年、フランスのラファール・レゾリヴィエールにルーメンセンターが創設されました。その創設はUAM*の最初の代表的な研究者でもあり、近代フランスデザイン界を象徴する人物でもあるジル・デレンがアートディレクションを担いました。
*UAM (Union des artistes modernes) は1928年から1958年まで活動し、国際的な近代芸術運動にまで発展しました。アイリーン・グレイ、シャルロット・ペリアン、ジャック・アドゥネが創設メンバーとしてその名を連ねています。ジャック・アドゥネは1929年に「クアドロ」をデザインしました。また、ピエール・シャローのためにはMCP (ピエール・シャローの追憶) が1979年に製品化されています。これは、商業的にも大成功を収め、モントリオール美術館に常設展示されています。

当時からフランスのルーメンセンターは、ミラノ工業地区の照明メーカーに製品の製造からカタログの作成まで依頼をしていました。その機関をルーメンセンター・イタリアと呼び、イタリア国内において商業展開も行っていました。その後、イタリアのメーカーがこの本家フランスのブランドを買収、これによって、国内外全てにおいて唯一のオーナーとしてその販売を行うこととなりました。その後もジャン＝ミッシェル・ウィルモット (テーブルランプ「フシントン」のデザイナー) をはじめとするフ

ランス人デザイナーたちとの密接なコラボレーションは行われました。家族経営と経営規模の縮小がおこなわれたにもかかわらず、この当時から、製品の品質が高いメーカーとして注目されており、イタリア国内をはじめ国際的な舞台においてその地盤を固めていきました。

90年代後半には大きなターニングポイントを迎えます。それは当時、DMCヴィットラスカ (アウグスト・グリッコ代表) が、日本の浦和バインズホテルのインテリアおよび照明デザイン計画のためルーメンセンター・イタリアと接触したことに始まります。「ライフリバー」と呼ばれた「テイラーメイド (特注)」デザインプロジェクトの中で、培われた生産技術は絶大な柔軟性を発揮し、今日にいたってもこのメーカーの最高水準の粋意を尽くしたものの代表的な作品となっています。DMCヴィットラスカは、既に1993年よりカラーライトの照明開発に着手しています。このプログラムは、魅力溢れるイタリアーグレッッチョ修道院にて数多くの専門家、研究者やデザイナーが参加した実験的なワークショップへと発展しました。この「ライフリバー」と「ヘリオポリス」の二つのプロジェクトが、2000年にヴィットラスカグループによってルーメンセンター・イタリアを買収するきっかけとなりました。これを境に、数多くの取り組みが国際的にも有数のレベルへと成長しました。

これを機に、前衛的で実験的な取り組みにおいても国際的な規模で数々のインシアチブを取っています。その例として「光」と「色」と「音」を同期させることによって行われる「シネステジア」、有機ELの照明用光源としての使用、光と人間の代謝の相互関係の研究結果としての最新LED光源の開発プロジェクト「ルーム / **luum**」などが挙げられます。

今日、ルーメンセンター・イタリアは極東市場における重要性を考慮し、日本の東京にLCIジャパンを開設しました。国際万博・Expo 2015 (イタリア・ミラノで開催) の日本館内部のフードコートの照明をスポンサーとして提供しました。さらに歴史あるアンブロジーアーナ絵画館 (イタリア・ミラノ・ヴァチカン市国所有) に収蔵されているレオナルド・ダヴィンチ、ティツィアーノ、ラファエロ、ブルーゲルやボッティチエッリ達の作品の照明機器を提供しています。

VILLATOSCA

DESIGN MANAGEMENT CENTRE

LUMEN CENTER ITALIA è parte del VillaTosca Design Management Centre - un'azienda specializzata nella gestione dei processi creativi - che, negli ultimi vent'anni, ha sviluppato metodologie innovative applicabili alle diverse fasi della progettazione: dalla ricerca tendenze, al concept di prodotti e servizi. L'anima del gruppo è il suo fondatore: Augusto Grillo - imprenditore, manager e sociologo dal percorso originale, contraddistinto dal profondo rapporto che lo lega con il Giappone, paese in cui ha studiato. Dal 2000, come proprietario e presidente di LUMEN CENTER ITALIA, ha guidato l'azienda in una direzione più internazionale ma l'ha anche trasformata in una azienda "design thinking" in cui Scienza e Umanesimo, Oriente ed Occidente, Numeri ed Estetica coesistono.

LUMEN CENTER ITALIA is part of VillaTosca Design Management Centre Group - a company specialized in managing creativity processes. In the last twenty years the company has developed innovative methodologies for the various phases of design from research on trends to the studies of concepts for products and processes. The soul of the Company is its founder, Augusto Grillo: entrepreneur, manager and sociologist who has a unique background, marked by the deep relationship that ties him to Japan, where he studied. Since 2000, Augusto Grillo has served as the owner and president of LUMEN CENTER ITALIA leading the company to a more international scope but also guiding it into a "design thinking" company in which Humanism and Science, West and East, Numbers and Aesthetics coexist.

ルーメンセンター・イタリアは、クリエイティブ事業に特化した組織である VillaTosca Design Management Centre グループの一員としても活動を行っています。過去20年間にわたり、トレンドの動向調査から製品・工程コンセプトの研究に至るまで、さまざまなデザイン段階において画期的な手法を開発してきました。ルーメンセンター・イタリアの企業精神は、代表者アウグスト・グリッコによって築かれました。起業家、マネージャー、社会学者など多彩な側面を持つグリッコは、日本への留学経験もあり、日本と深いかわりがあります。グリッコは2000年からルーメンセンター・イタリアのオーナー兼社長として就任し、当社をさらに国際的な舞台に導くと同時に、ヒューマニズムと科学、西洋と東洋、数字と美が共存するデザイン志向の企業として成長させてきました。

MILESTONES

LUMEN CENTER ITALIA

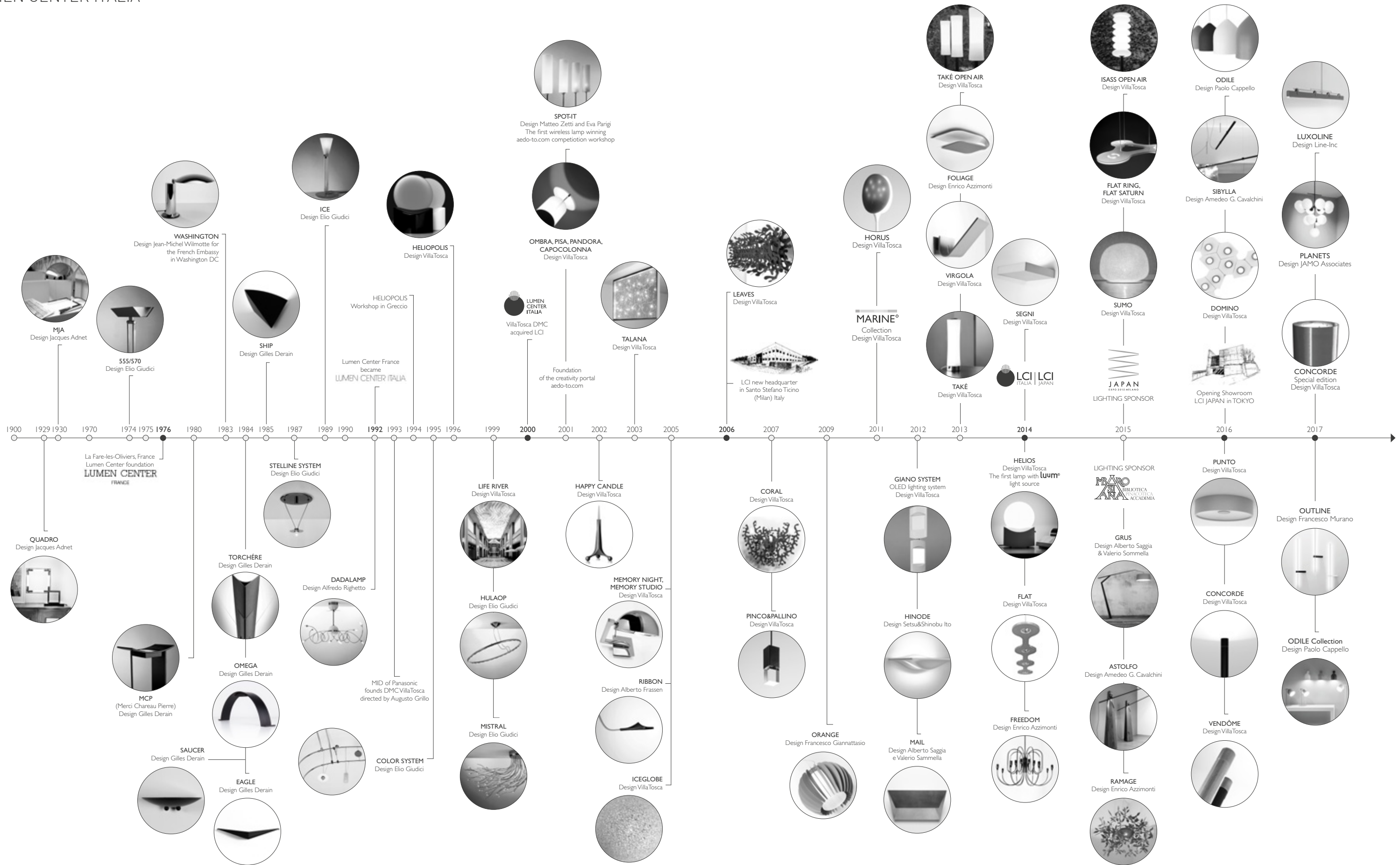

DESIGNER

lumencenteritalia.com/designers



ALBERTO SAGGIA /
VALERIO SOMMELLA



AMEDEO G. CAVALCHINI
www.studiocavalchini.com



BERNARD BROUSSE
www.bernardbrousse.com



ENRICO AZZIMONTI
www.enricoazzimonti.it



FRANCESCO GIANNATTASIO
www.francescogiannattasio.it



FRANCESCO MURANO
www.francescomurano.it

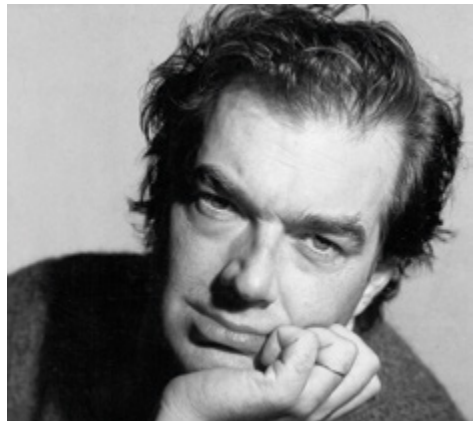

GILLES DERAÏN



JACQUES ADNET



JAMO ASSOCIATES
www.jamo.jp



JEAN-MICHEL WILMOTTE
www.wilmotte.com



LINE INC.
www.line-inc.co.jp



MARIO MAZZER
www.mariomazzer.it



NAKATA DESIGN



PAOLO CAPPELLO
www.paolocappello.com



SETSU&SHINOBU ITO
www.studioito.com

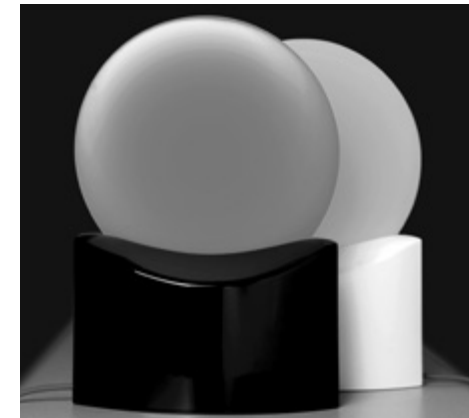

VILLATOSCA
www.dmcvillatosca.it

INDEX

CONTEMPORARY

	GRUS	14	
	NEW CONCORDE	18	
	VENDÔME	22	
	ASTOLFO LIM. ED.	26	
	ASTOLFO HT	30	
	NEW ODILE TERRA	32	
	NEW ODILE TAVOLO	32	
	NEW ODILE PARETE	32	
	ODILE S/M	36	
	ODILE PENDANT 3/5	38	
	NEW BRICK QUADRO 1/4	40	
	NEW BRICK RETTO 2/4	40	
	NEW BRAC 1/4	44	
	NEW BRAC 6/10	44	
	NEW DOMINO	48	
	NEW DOMINO ZERO	48	
	PUNTO	54	
	PUNTO P	54	
	NEW FOLIAGE 2700	58	
	NEW FOLIAGE 2700 P	58	
	NEW OUTLINE	62	
	HINODE	66	
	MAIL	70	
	MAIL S	70	
	MAIL L/XL	74	

SEGNO QUADRO	76	
SEGNO RETTO	76	
SEGNO TONDO	76	
SEGNO MAXI QUADRO	80	
SEGNO MAXI RETTO	80	
SEGNO MAXI DOUBLE	80	
VIRGOLA	82	
PINCO 21/21-I	86	
PINCO S/S-I	86	
PALLINO 21/21-I	90	
PALLINO S/S-I	90	
NEW LUXOLINE	92	
NEW LUXOLINE A/V	96	
NEW PLANETS	98	
FREEDOM 10L/16L	102	
FLAT 04/05/06	106	
FLAT RING 3/6/12	110	
FLAT SATURN 1/2/3	112	
NEW SIBYLLA BT S/M/L	114	
TAKÉ PLUS TOUCH 01	118	
TAKÉ PLUS TOUCH 02/03	118	
TAKÉ PLUS TOUCH 04/05/06	122	
TAKÉ PLUS BT OVAL 05	124	
TAKÉ PLUS BT OVAL 06	124	
TAKÉ PLUS BT S&P 04/05/06	126	
TAKÉ PLUS ON-OFF S1/S2/S3	128	
TAKÉ PLUS ON-OFF S4/S5/S6	130	
TAKÉ 27/27-I	132	
TAKÉ BUBBLE 04/08	132	

TAKÉ OPEN AIR 03	134	
TAKÉ OPEN AIR 10	134	
TAKÉ OPEN AIR 11	134	
TAKÉ OPEN AIR 21	134	
IG 02/L02	138	
IG MAXI 02/GIANT 02	138	
IG 10/11/12	142	
IG L10/L11/L12	144	
IG 21/21L	146	
ICEGLOBE S/LS	148	
IG MAXI S	148	
IG GIANT S	148	
IG SEMI MAXI	150	
IG SEMI GIANT	150	
IG BUBBLE 3/5/10	152	
IG BUBBLE MINI 3/5/10	152	
ICEGLOBE MINI 02	154	
IG MINI S	154	
IG MINI 21	154	
IG MINI 21B/21BL	156	
ICEGLOBE MICRO 03	158	
IG MICRO 21/21-I	158	
IG MICRO S/S-I	158	
IG MICRO BUBBLE 4/8/12/16	160	
ICELIGHT 20/30/45/60/60SEMI	162	
ICELIGHT PEN 3/5	165	
SUMO S/M/L/X	166	
SUMO 21/M21/L21	170	
SUMO 02/M02/L02/X02	172	
CORAL	174	
CORAL P	174	

SUPERCORAL 8L	178	
SUPERCORAL 16L	178	
MINICORAL S	180	
MINICORAL A	180	
MINICORAL P	180	
LEAVES S	182	
LEAVES 21	182	
MIDLEAVES	186	
SUPERLEAVES	186	
RAMAGE	188	

CLASSIC

NEW QUADRO VII RE-ED.	194	
NEW MJA LIM. ED.	196	
NEW MEMORY STUDIO LIM. ED.	198	
OMEGA LED	200	
WASHINGTON LED	202	
MCP LED	204	
VICTORY LED	206	
555 LED/570 LED	208	
BLUM LED	210	
EAGLE LED	212	
TRYLON LED	214	
TORCHÈRE LED	216	

CONTEMPORARY

GRUS

Design Alberto Saggia+Valerio Sommella



UNA GRU DI LUCE

A CRANE OF LIGHT

光のクレーン

GRUS metafora geometrica degli eleganti volatili dalle lunghe zampe e di una piccola costellazione, la cui conformazione ricorda proprio la figura di una "gru" pronta a spiccare il volo, la nuova lampada da terra disegnata da Alberto Saggia e Valerio Sommella per LUMEN CENTER ITALIA.

GRUS geometric metaphor of elegant birds with long paws and also of the homonym small constellation - named in latin Grus - whose stars seems to draw a crane ready to take off. This is the concept behind the new floor lamp designed by Alberto Saggia e Valerio Sommella for LUMEN CENTER ITALIA.

長い脚を持つ優雅な鳥「鶴」の幾何学的な隠喩とその姿を象った星座の「ツル座」。この空に飛び立つ「鶴」を思わせる「グルース」は、ルーメンセンター・イタリアのためにアルベルト・サッジャとヴァレリオ・ソムメッラによってデザインされた新しいフロアランプです。

GRUS

Design Alberto Saggia+Valerio Sommella

Lampada da terra con punto luce decentrato caratterizzata da un'esile struttura geometrica realizzata in lamiera verniciata e disponibile nelle finiture grigio grafite o grigio perla. La struttura portante è divisa in due parti - una imperniata sull'altra - tenute in tensione da un cavo metallico che scorre parallelo alla struttura e fissato alla base romboidale. La regolazione della tensione del cavo consente la regolazione in altezza del grande diffusore in tessuto che nasconde la sorgente luminosa. Diffusore disponibile nelle finiture white, red wine e sage.

Floor lamp with decentralized lighting spot and with a thin geometric structure finely realized in aluminium sheet and available in graphite grey or pearl grey finishes. The framework is composed of two parts, one pivoted on the other, fixed by a metal adjustable wire along the structure and set on the metal rhomboidal base. The adjustment of the metal wire allows height regulation of the large textile diffuser that hides the light source. Diffuser available in three colours: white, red wine and sage.

薄いスチールパネルによって幾何学的に構成されたアームを持つフロアーランプ。グラファイト・グレーとパール・グレーの二種類の塗装が用意されています。ヒンジ結合で重ね合わせた二つのパーツの構造体を平行の吊りワイヤーを介してひし形底座に固定します。この吊りワイヤーの長さを調整することによって光源を内蔵した布製の大きなセードの高さを調節が可能です。セードのカラーは、ホワイト、レッドワイン、ホワイトセージの3種類が用意されています。

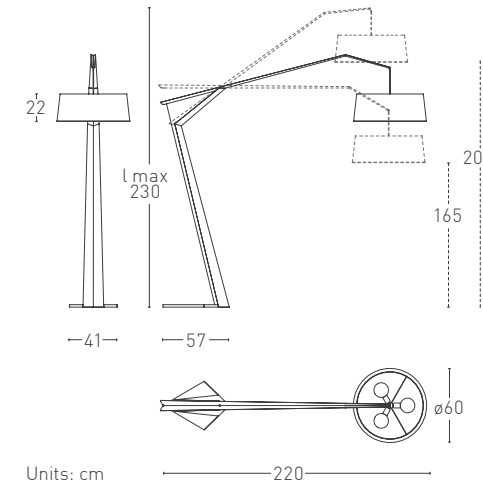

Finishes

- 115D FT Graphite grey
- 123 Pearl grey

Diffuser

- BC White
- R Red wine
- W Sage

Cable

Transparent

Dimmer

Included

Suggested light source

220/240V E27
100/120V E26

- Halogen ECO max 3x77W
- LED dimmable min 5W

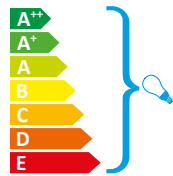

Certification



CONCORDE

Design VillaTosca



MONOLITE LUMINOSO

La *Ville Lumière* e una delle sue piazze più antiche e monumentali sono lo scenario a cui si ispira la lampada da terra CONCORDE. Affusolata e statuaria come un monolite, cilindrica e in metallo, cita l'obelisco della celebre piazza a pochi passi dagli eleganti Champs Elysées e ne rielabora la silhouette in una linea semplice e stilizzata. La cornice cromata alla sommità e alla base dà una piacevole sensazione di leggerezza. CONCORDE trova il suo naturale completamento nel progetto VENDÔME, lampada da terra ispirata a un altro dei luoghi storici di Parigi.

BRIGHT MONOLITH

The *Ville Lumière* and one of its oldest and most monumental squares are the scenario that inspired the floor lamp CONCORDE. Slight and majestic as a monolith, cylindrical and made of metal, it reminds the famous obelisk of the square close to the elegant Champs Elysées, as a silhouette in a simple and stylised line. The chrome frame at the top and base gives a pleasant feeling of lightness. CONCORDE finds its natural completion in VENDÔME, floor lamp inspired by another of the historical sites of Paris.

光るモノリス

輝く宮殿と最も古い広場の一つコンコルド広場、フロアランプ『コンコルド』はそこにそびえ立つ記念碑にインスピレーションを得ました。まるでモノリスのような細い彫像は円筒の金属製であり、その姿はシャンゼリゼ通りの先にそびえ立つオベリスクを思わせます。究極的に簡潔なシルエットを持ち、土台のある根元と、そこからスッと心地よく上部伸びた先にアクセントとなるクロム仕上げのリングが輝きます。『コンコルド』はやはりフランスの歴史的背景からインスピレーションを得た『ヴァンドーム』プロジェクトから派生したものです。



CONCORDE

Design VillaTosca

Un monolite in metallo cilindrico di 179 cm di altezza. La cornice cromata della sua sommità e lo scuretto della base alleggeriscono e rendono piacevole la semplicità della forma. Luce diretta verso l'alto. Nuova finitura in Red Montenapo + Satin Brass disponibile.

A cylindrical monolith in metal, height 179 cm. The chrome frame of his top and the shutter base lighten and make pleasant the simplicity of the form. Direct light upward. New finish in Red Montenapo + Satin Brass available.

高さ179 cm、金属製円筒のモノリス。シンプルなフォルムの中に上部と下部2か所のクロムメッキのアクセントが心地よく同居します。光は本体上部からの直接光になります。

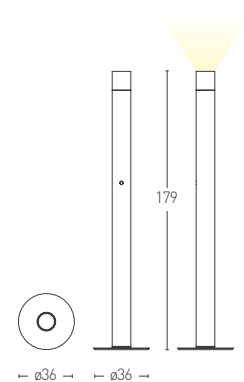

Units: cm



Finishes

- 103 FT Black + ● 150 Chrome
- 105 FT White + ● 150 Chrome
- 128 Red Montenapo + ● 152 Satin brass

Diffuser

PMMA methacrylate diffuser

Electronic driver

Dimmable included

Cable

Black fabric

Light source

LED

220/240V

LED 50W 4800lm 2700K CRI>90

100/120V

LED 36W 3500lm 2700K CRI>90

A

Certification

CE EAC PS E F IP20



VENDÔME

Design VillaTosca



COLONNA DI LEGNO E METALLO

La lampada da terra VENDÔME è come un frammento dello skyline di Parigi, città delle luci per eccellenza. Allungata e monolitica, evoca in chiave stilizzata la colonna attorno a cui si apre una delle piazze più famose del mondo. E dalla raffinatezza di Place VENDÔME, meta dello shopping e del lusso nel cuore elegante di Parigi, la lampada progettata da VillaTosca trae ispirazione per i materiali. Legno di rovere massello naturale e rovere massello tinto nero a poro aperto, caldo e prezioso, con dettagli metallici in bronzo e rame.

Il progetto VENDÔME trova il suo alter ego nella lampada da terra CONCORDE, ispirata a un altro dei luoghi simbolo Parigini.

METAL AND WOOD COLUMN

VENDÔME floor lamp is like a fragment of the skyline of Paris, the city of lights for excellence. Lengthened, monolithic, this lamp evokes the column of one of the most famous squares in the world. By the sophistication of Place VENDÔME, fancy shopping destination in the elegant heart of Paris, the lamp designed by VillaTosca gets inspiration for materials. Natural solid oak wood or open-pore solid oak black stained, warm and unique, with metal details in bronze or copper.

Vendôme finds its alter ego in CONCORDE, floor lamp, inspired by another symbol place of Paris.

木と金属からなる柱

フロアーランプ『ヴァンドーム』はパリの街の美しいスカイラインの光を切り取ったようなランプです。

細長いモノリスは世界でも有数の有名なヴァンドーム広場に収まる柱の様にも見えます。ヴァンドーム広場はパリの中でもとてもエレガントな高級ショッピングエリアの中央に位置し、VillaTosca Designはそこからインスピレーションを得て、素材を吟味いたしました。

温かみと高級感を醸し出す、天然の無垢オーク材はナチュラルカラーと黒色染め、金属部は真鍮と銅を使用しました。

フロアーランプ『コンコルド』は『ヴァンドーム』同様、パリのシンボルに触発されて開発された姉妹品です。

VENDÔME

Design VillaTosca

Un monolite cilindrico in legno e metallo dalle diverse finiture di 179 cm di altezza. Luce indiretta da atmosfera attraverso la striscia di luce verticale inserita lungo il fusto in legno e luce più potente posizionata nella sua sommità e rivolta verso l'alto rendono VENDÔME una lampada flessibile nell'uso e ricercata nelle soluzioni. La morbidezza e il colore del legno opposta alla durezza del metallo ne fanno un oggetto di arredo facilmente integrabile in molte tipologie stilistiche.

A cylindrical monolith of 179 cm in height in wood and metal by various finishes. The vertical light strip inserted along the wooden frame to create a warmer atmosphere and more powerful light positioned in its top facing upward make VENDÔME a flexible lamp in use and refined in the solutions. The softness and colour of the wood opposite to the hardness of the metal make Vendome an object that can be easily integrated into many stylistic decor types.

高さ179 cm、複数の金属と木材の融合による円筒のモノリス『ヴァンドーム』は木製フレームに内蔵された縦長の間接照明と本体上部から天井に向けて照射される強力な光のコンビネーションを持っており、様々な環境に対して柔軟に対応が可能です。特徴的な柔らかな木の色の温もりとそれに相反する金属の融合を持つこのランプは様々なインテリアの中に調和しつつもその存在を主張することでしょう。

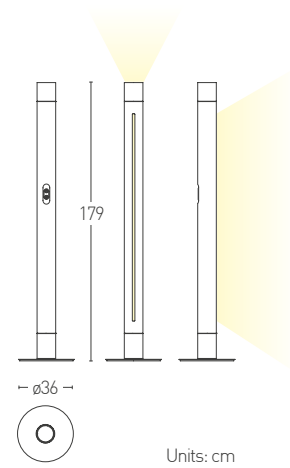

Units: cm



Finishes

- LR Oak + ● 176 Bronzed brass
- LRN Black Oak + ● 177 Copper plated brass

Diffuser

PMMA methacrylate diffuser

Electronic driver

Dimmable included

Cable

Black fabric

Light source

LED

- UP **LED** 100/120V light indirect 36W
3500lm 2700K CRI>90
- UP **LED** 220/240V light indirect 50W
4800lm 2700K CRI>90
- BACK **LED** 100/240V light diffused 24W
2160lm 3000K CRI>90

A

Certification

CE EAC PS E F IP20



ASTOLFO

Design Amedeo G. Cavalchini

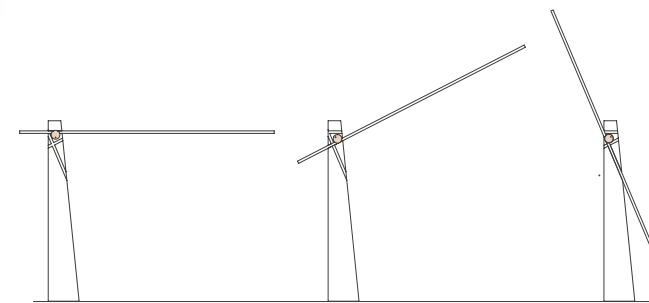

CAVALIERE LUMINOSO

L'epica cavalleresca offre lo spunto progettuale per la lampada da terra ASTOLFO, connubio tra la struttura ancestrale e rassicurante del legno e la tecnologia estrema della sorgente LED e del profilo minimale. Il suo design emula l'ordinato grafismo di una lancia luminosa, sottile e tecnologica, inserita meccanicamente in un fusto di legno massiccio attraversato da tagli netti e precisi, in cui la lancia può essere inserita secondo tre diversi angoli e orientamenti.

BRIGHT KNIGHT

The chivalrous epic inspires the floor lamp ASTOLFO, melting the ancestral and soothing structure of wood, the extreme technology of LED source and its minimal outline. Its design emulates the linear graphism of a light spear, thin and technological, mechanically inserted in a solid wood stem crossed by sharp and precise carves, where the light-spear can be placed in three different angles and orientations.

輝く騎士 (ナイト)

騎士の抒情詩が、このフロアーランプ「アストルフォ」のデザインの出発点となりました。不変とも言える天然木から作られた構造体と与える安心感に、ミニマルなラインで作られた最新技術のLED光源を融合させました。見た目にも特徴的なこの精悍な細く光る「テクノロジーの槍」とも言える発光部が、木製の台座に刻まれた溝の中に納まります。この溝によって3つの違う角度に向きが変えられます。

ASTOLFO LIMITED EDITION

Design Amedeo G. Cavalchini

Lampada da terra con doppia sorgente luminosa LED. Costituita da una base in legno massello di rovere o noce nazionale e un'asta in alluminio anodizzato di colore nero. Le tre scanalature presenti nella parte superiore della base consentono all'asta di essere posizionata con tre differenti angoli rispetto alla base stessa, consentendo un approccio tattile e personale con la lampada.

Le sorgenti LED dimmerabili sono collocate lungo l'asta e nel retro della base consentendo un'illuminazione sia diretta che indiretta.

Floor lamp with double LED light sources. Solid oak or walnut base and arm in black anodized aluminum. Three carves on the top of the trunk allow to place the arm in three different angles giving the lamp a personal touch. The dimmable LED sources are along the arm and on the base back, creating both indirect and direct lighting.

二重のLED光源を持つフロアーランプ。ウォールナットまたはオークの無垢木材のベースにアルミ製ブラック・アルマイト仕上げのアーム。台座の上部に刻まれた溝は、アーム部分を三つの異なる角度に固定することができます。これによってこのランプは、見た目と空間と共に自由なアプローチを生み出す事が可能です。アーム部分とベースの背面に内蔵されたLED光源は、調光が可能で、直接照明と間接照明の二種類のあかりを同時に演出します。

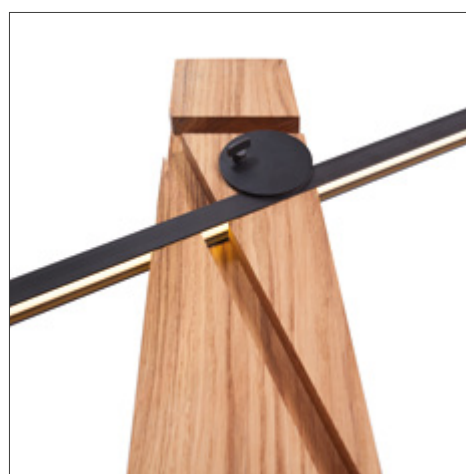
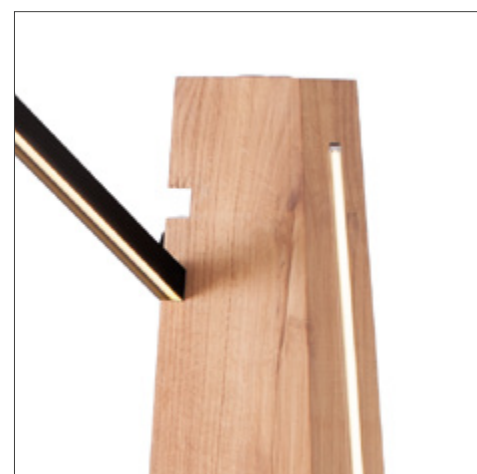
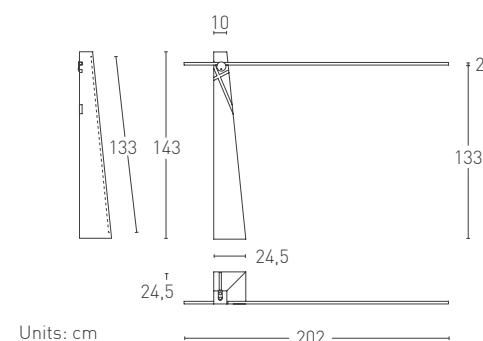

Finishes

- LN Walnut
- LR Oak

Diffuser

- 174 Black anodized aluminum

Cable

Black fabric

Electronic driver

Dimmable included

Light source

LED

ARM **LED** 36W 100/120V or 220/240V
3240lm 3000K CRI>90
BACK **LED** 24W 100/120V or 220/240V
2160lm 3000K CRI>90

A

Certification



ASTOLFO HT

Design Amedeo G. Cavalchini

Lampada da terra con base realizzata in scatolato di acciaio verniciato e fronte in massello di rovere. Le tre scanalature presenti nella parte superiore della base consentono all'asta luminosa - realizzata in alluminio anodizzato nero - di essere posizionata con tre differenti angoli rispetto alla base stessa, consentendo un approccio tattile e personale con la lampada.

La sorgente LED dimmerabile collocata nell'asta fornisce luce diretta o indiretta a seconda del posizionamento.

Floor lamp with folded sheet steel case and front cover in solid oak. Three carves on the top of the trunk allow to place the arm - with black anodized aluminum finish - in three different angles giving the lamp a personal touch.

The dimmable LED source placed along the arm gives direct or indirect light according to the different positioning.

スチール製ケースの台座にウォールナットまたはオークの無垢木材のファサード（表面）を使用したフロアランプ。台座の上部に刻まれた溝は、アーム部分を三つの異なる角度に固定することができます。これによってこのランプは、見た目と空間と共に自由なアプローチを生み出す事が可能です。

アーム部分は直接照明と間接照明の二種類のあかりを好みの配置によって選ぶことができます。

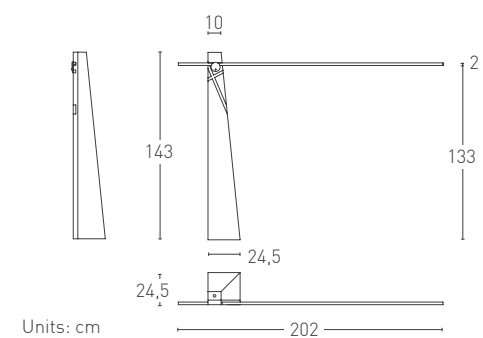

Finishes

- 115D FT Graphite grey + ● LR Oak

Diffuser

- 174 Black anodized aluminum

Cable

Black fabric

Electronic driver

Dimmable included

Light source

LED

LED 36W 100/120V or 220/240V
3240lm 3000K CRI>90



Certification

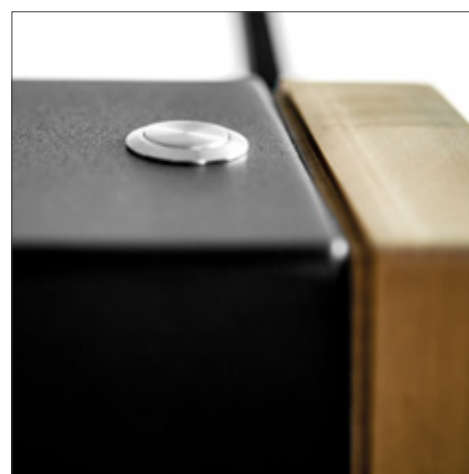
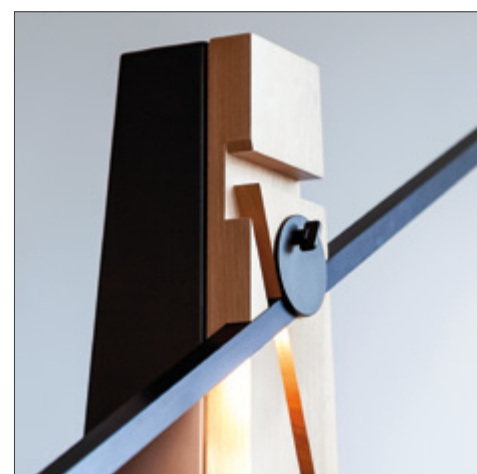

ODILE COLLECTION

Design Paolo Cappello



SEMPLICITA' ED EQUILIBRIO

Morbida e iconica collezione che unisce l'essenzialità e l'eleganza delle forme alla semplicità e all'equilibrio delle linee.

SIMPLICITY AND BALANCE

Soft and iconic collection that combines essentiality and elegance of forms to simplicity and balance of lines.

シンプルでバランスの取れたデザイン

優雅さとシンプルさが調和したシルエット。柔らかな印象でアイコン的なコレクションです。

ODILE TERRA/LETTURA/PARETE

Design Paolo Cappello

La collezione si arricchisce della versione applique ODILE PARETE, terra ODILE TERRA e tavolo ODILE LETTURA. Il design pulito e i colori pastello donano una piacevole sensazione di semplicità ed equilibrio. Struttura in metallo e calotta in alluminio, verniciate a polveri epossidiche.

The collection enriches with bracket lamp ODILE PARETE, floor stand ODILE TERRA and table ODILE LETTURA versions. Its smart design and pastel colours give a pleasant sensation of simplicity and balance. Metal structure and aluminum shade, epoxidic powder paint finishes.

『オディーレ』はこれまでのペンダントタイプに、ウォールタイプ(パレーテ)、フロアタイプ(テッラ)、テーブルタイプ(レットウーラ)の3種類が加わりました。洗練されたデザインと柔らかな色彩は明るい気分にしてくれます。アルミニウム製のシェードは粉体塗装(パウダーコーティング)です。

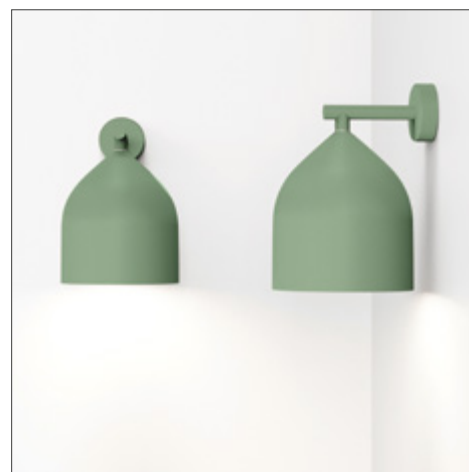
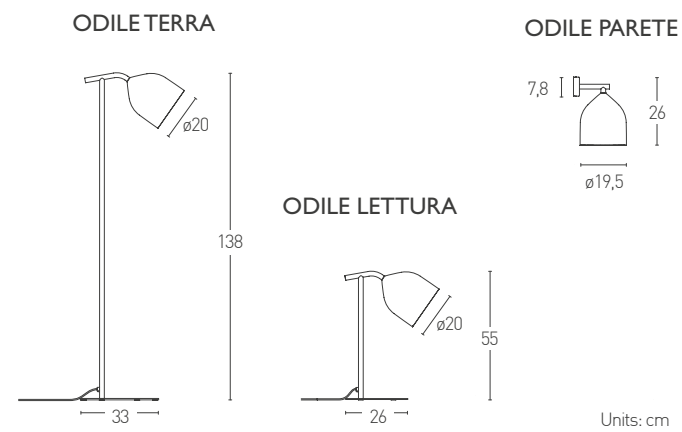

Finishes

- 105 FT White
- 125 FT Anthracite grey
- 126 FT Sage green
- 127 FT Senape

Cable

Transparent

Suggested light source

- 220/240V E27
- 100/120V E26
- Halogen ECO max 57W
- ECO Fluo
- LED

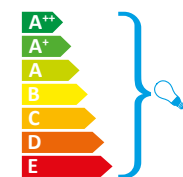

Certification



ODILE PARETE Classe I



ODILE S/M

Design Paolo Cappello

Forme sussurate, linee tratteggiate con dolcezza e uno studio del colore che rende l'effetto d'insieme ancora più gentile e delicato. Le lampade a sospensione ODILE, con la loro avvolgente silhouette a campana, sono una presenza misurata e elegante nello spazio. La palette di toni pastello mat, per i modelli proposti in due dimensioni, valorizza con discrezione la purezza del design.

Whispered shapes, sweet outlines and color study make ODILE, suspension lamp, delicate and gentle.

With its charming silhouette, the suspension ODILE is an elegant and chic furnishing element. The matte pastel tones palette, for the following models proposed in two dimensions, enhance with discretion the design purity.

ささやくような淡いフォルム、消え入るような繊細な線、甘く柔らかな雰囲気と色の探求、その全てが一つに合わさり誰もが好むであろう、一つの結果に集約します。

『オディーレ』は鐘のようなシルエットを纏ったペンダントランプであり、ご使用になる様々な空間どこであってもエレガントな存在感を示します。

表面の仕上げはパステル調の柔らかなつや無し塗装で、形は究極に研ぎ澄まされた大小違ったフォルムの2種類からなります。

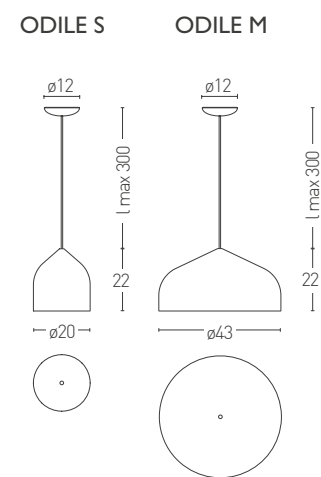

Units: cm



Finishes

- 105 FT White
- 125 FT Anthracite grey
- 126 FT Sage green
- 127 FT Senape

Ceiling rose

ABS white

Cable

Transparent

Suggested light source

220/240V E27

100/120V E26

Halogen ECO

ODILE S 1x57W max

ODILE M 1x77W max

ECO Fluo

LED

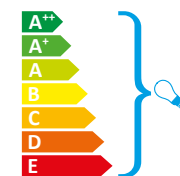

Certification



ODILE PENDANT 3/5

Design Paolo Cappello

Attacco al soffitto bianco opaco dotato di 3 o 5 bracci disposti a raggera che consente la libera configurazione delle sospensioni ODILE S e M.

Matte white ceiling connection provided with 3 or 5 ray system arms that makes possible the free configuration of suspension lamps ODILE S and M.

『オディーレ』SとMをお好きな組み合わせでまとめることのできるアタッチメントです。3本もしくは5本の放射状に広がるアームを持つ天井用ベースキットはつや消しのホワイト仕上げです。



Finishes

- 105 FT White
- 125 FT Anthracite grey
- 126 FT Sage green
- 127 FT Senape

Ceiling rose

- 106 Matte white

Cable

Transparent

Suggested light source

220/240V E27

100/120V E26

Halogen ECO

ODILE S 1x57W max

ODILE M 1x77W max

ECO Fluo

LED

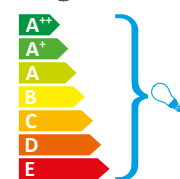

Certification



ODILE PENDANT 3

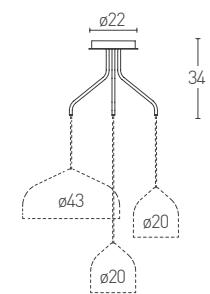

— ø max 80 —

ODILE PENDANT 5

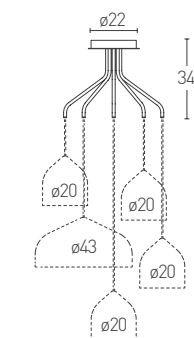

— ø max 80 —

Units: cm



BRICK

Design VillaTosca



FORME ELEMENTARI

Forme elementari, BRICK richiama alla mente i mattoncini della nostra infanzia. Cerchi di luce iscritti nelle più rigide geometrie del quadrato e del rettangolo.

ELEMENTARY FORM

Elementary forms, BRICK recalls the playing bricks of our childhood. Circles of light inserted in the most rigid geometries of the square and the rectangle.

ベーシックなフォルム

ベーシックなフォルムを纏ったシーリングランプです。『不朽』とも言えるそのシンプルなデザインは、子供の頃に見たブロックを連想させます。円状の光は幾何学的形状の代表ともいえる正方形と長方形の板面にその姿を落とします。

BRICK QUADRO 1/4 - RETTO 2/4

Design VillaTosca

Ingenuità e rigore si uniscono in questa plafoniera dal design essenziale, quasi grafico. Tre moduli base. Un quadrato e due rettangoli nei quali sono iscritti cerchi di luce. Mattoncini luminosi da usare singolarmente o da accostare liberamente, per costruire soluzioni geometriche di qualunque dimensione e per ogni tipologia di ambiente.

Realizzati in metallo con finitura Bianco Fine Textured (FT) e anelli cromati.

Nuovi colori disponibili a pagina 52.

Naivety and rigour are combined in this ceiling lamp of essential design, almost graphic. Three basic modules: a square and two rectangles in which circles of light are inscribed. Bright bricks that can be combined individually or stacked freely, for building geometric solutions of any size and for any type of location.

Made of metal with Fine Textured (FT) White finish and chromed rings.

New colours available on page 52.

創意工夫を凝らし天井に緻密にベーシックなフォルムを並べ、お気に入りの形を創作する楽しさ、それはまるでグラフィックデザインの世界です。

構成は3つの基本形、正方形と2つの別の形の長方形となっており、その上に円形の光源が収まります。

単品でもご使用いただけますが、空間にあわせて複数を組み合わせてより魅力的な空間を創作して頂くことも可能です。素材はメタル製で仕上げは複数色のファインテクスチャー(FT)と箔仕上げ、光源部のリングはクロムメッキと複数色のファインテクスチャー(FT)です。



Finishes

Lamp body:

- 105 FT White (W)
- 138 Titanium (T)
- 126 FT Sage green (G)
- 115R Sand grey (S)
- 139 Cor-ten (N)
- 130 Gold foil (O)
- 131 Silver foil (A)

Ring:

- 105 FT White (W)
- 138 Titanium (T)
- 126 FT Sage green (G)
- 115R Sand grey (S)
- 139 Cor-ten (N)
- 119 Chartreuse green (H)
- 120 Red (R)
- 150 Chrome (C)
- 152 Satin Brass (B)

Diffuser

PMMA methacrylate diffuser
WIDE / MEDIUM / HONEY COMB

Electronic driver

Dimmable included TRIAC

Light source

LED

100/120V or 220/240V
2700K/3000K/4000K CRI>90

QUADRO 1 1x5,8W 690lm

QUADRO 4 4x5,8W 2760lm

RETTO 2 2x5,8W 1380lm

RETTO 4 4x5,8W 2760lm

A

Certification

CE EAC PS E F IP20 Classe I

OPTIONAL SPEAKER BT ACCESSORY

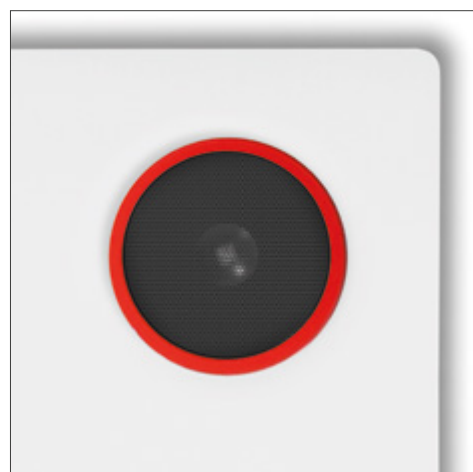

QUADRO 1

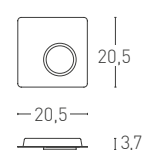

QUADRO 4

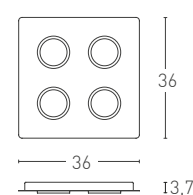

RETTO 2

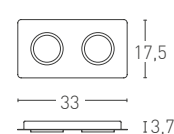

RETTO 4

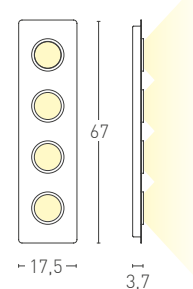

Units: cm



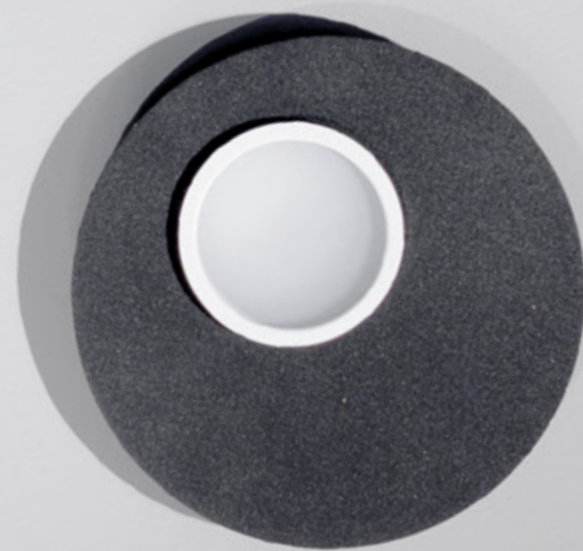

PUREZZA DEL CERCHIO

La purezza del cerchio che include altri cerchi di luce posti in libertà. Un ossimoro che sorprende ed esalta la semplicità del cerchio.

CIRCLE PURITY

The purity of the circle that includes other circles of lights placed freely. An oxymoron that surprises and underlines the simplicity of the circle.

純粹な円

魅惑的なデザインのシーリングランプです。真円の上いくつかの光の円が自由に配置されています。シンプルな円のみで構成されているのに、驚きを与える辺りの矛盾さをデザインに生かしました。

BRAC 1/4/6/10

Design VillaTosca

Le plafoniere BRAC, nella loro purezza e semplicità, disegnano cerchi di luce che richiamano cangianti giochi d'acqua. Gocce di luce distribuite con apparente casualità su una superficie rotonda. La purezza del design offre nuove suggestioni. Moltiplicate a soffitto le lampade BRAC creano composizioni dinamiche.

Realizzati in metallo con finitura Bianco Fine Textured (FT) e anelli cromati.

Nuovi colori disponibili a pagina 52.

The ceiling lamps BRAC, in their simplicity and minimalism, draw light circles that remind bright water effects. Drops of light arranged on a round surface. The design purity always offers new suggestions.

Several BRAC ceiling lamps create dynamic compositions.

Made of metal with Fine Textured (FT) White finish and chromed rings.

New colours available on page 52.

シーリングタイプの照明『ブラック』は、ミニマリズム的なシンプルさの中に描かれた光の水滴を思わせる光源を持ち、その光のしずくは円状の表面に広がります。デザインは基本に立ち返った時に常に何か新しい提案を与えてくれます。もし「BRAC」を複数組み合わせれば思いがけない空間を創作できることでしょう。素材はメタル製で仕上げは複数色のファインテクスチャー(FT)と箔仕上げ、光源部のリングはクロムメッキと複数色のファインテクスチャー(FT)です。

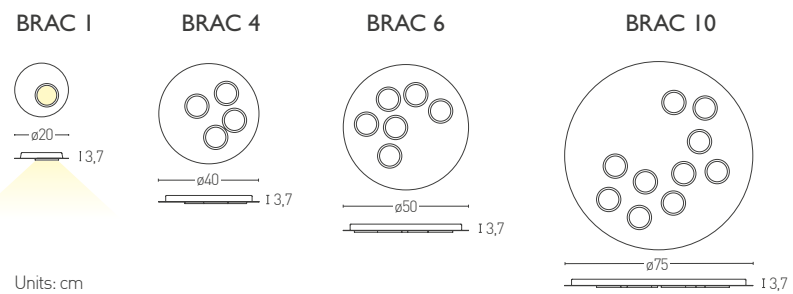

OPTIONAL OKKIO SPOT ACCESSORY

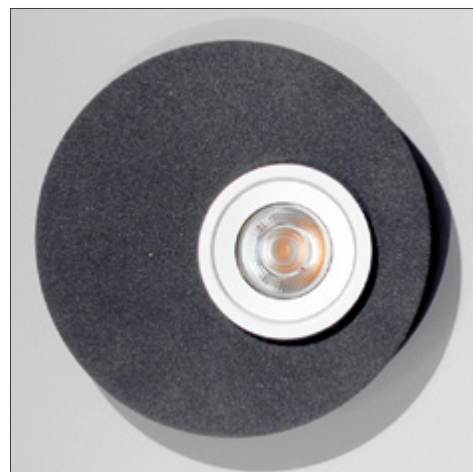

Finishes

Lamp body:

- 105 FT White (W)
- 138 Titanium (T)
- 126 FT Sage green (G)
- 115R Sand grey (S)
- 139 Cor-ten (N)
- 130 Gold foil (O)
- 131 Silver foil (A)

Ring:

- 105 FT White (W)
- 138 Titanium (T)
- 126 FT Sage green (G)
- 115R Sand grey (S)
- 139 Cor-ten (N)
- 119 Chartreuse green (H)
- 120 Red (R)
- 150 Chrome (C)
- 152 Satin Brass (B)

Diffuser

PMMA methacrylate diffuser
WIDE / MEDIUM / HONEY COMB

Electronic driver

Dimmable included TRIAC

Light source

LED

100/120V or 220/240V
2700K/3000K/4000K CRI>90
BRAC 1 1x5,8W 690lm
BRAC 4 4x5,8W 2760lm
BRAC 6 6x5,8W 4140lm
BRAC 10 10x5,8W 6950lm

A

Certification

CE EAC PS E F IP20 Classe I

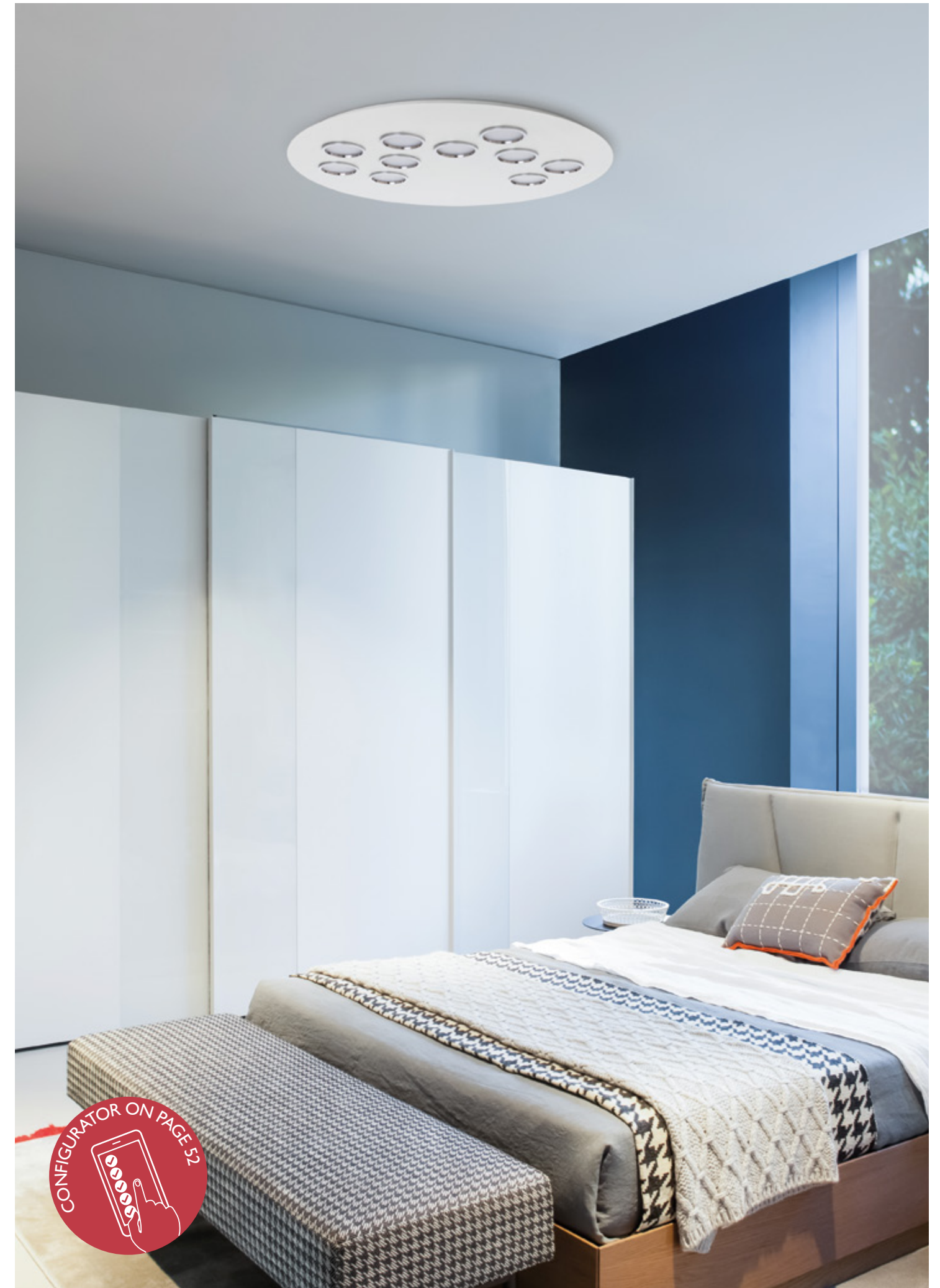

DOMINO

Design VillaTosca

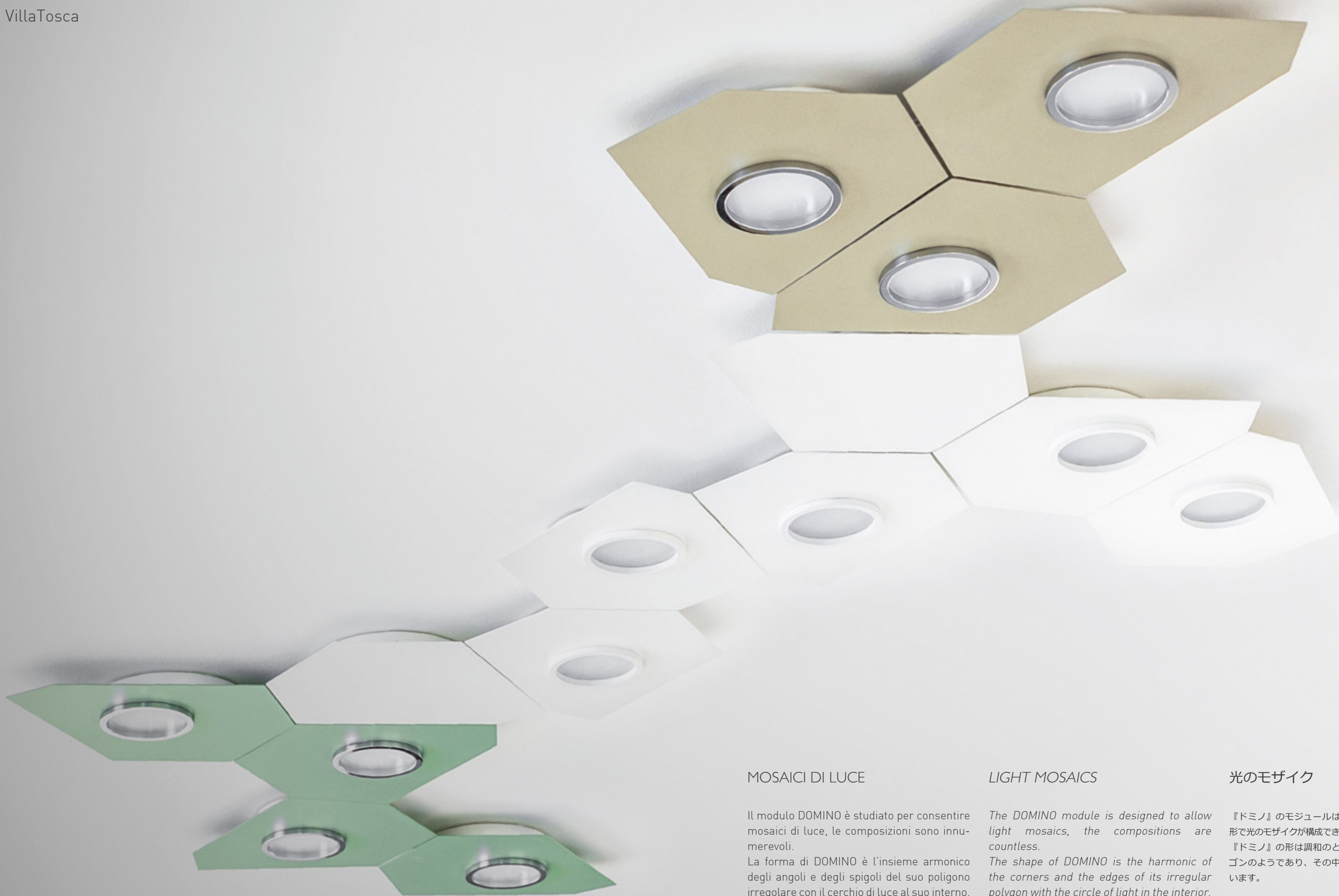

MOSAICI DI LUCE

Il modulo DOMINO è studiato per consentire mosaici di luce, le composizioni sono innumerevoli.

La forma di DOMINO è l'insieme armonico degli angoli e degli spigoli del suo poligono irregolare con il cerchio di luce al suo interno.

LIGHT MOSAICS

The DOMINO module is designed to allow light mosaics, the compositions are countless.

The shape of DOMINO is the harmonic of the corners and the edges of its irregular polygon with the circle of light in the interior.

光のモザイク

『ドミノ』のモジュールは数え切れないほどの様々な形で光のモザイクが構成できるように考えられています。

『ドミノ』の形は調和のとれた角度で構成されたポリゴンのものであり、その中心には真円の光が収まっています。

DOMINO

Design VillaTosca

Un esagono irregolare e un cerchio di luce al suo interno. Questa è la matrice di infinite combinazioni possibili. DOMINO è un nuovo concetto di plafoniera. Un sistema che invita a comporre e accostare le diverse tessere di un mosaico di luce sempre diverso. Come nell'antico gioco cinese del tangram o in un frattale della natura, la logica delle composizioni è aperta e creativa. Realizzati in metallo con finitura Bianco Fine Textured (FT) e anelli cromati.

Nuovi colori disponibili a pagina 52

An irregular hexagon and a light circle in its inside. This is the origin of possible endless combinations. DOMINO is a new concept of ceiling lamp. A system that invites to combine different tiles of an always new light mosaic. As in the Chinese game of tangram or in a nature fractal, the logic of the compositions is open and creative.

Made of metal with Fine Textured (FT) White finish and chromed rings.

New colours available on page 52.

不規則な六角形の中心に光の輪。これは無限の組合せが可能なマトリックス(基盤)です。『ドミノ』は天井の新しい概念です。光のモザイクは無限の組み合わせにより様々な違った空間へあなたを誘います。

それはタングラム(古代中国のパズル)や自然界のフラクタルの様にあなたの開かれたアイデアの前で無限に広がっていくでしょう。素材はメタル製で仕上げは複数のファインテクスチャー(FT)と箔仕上げ、光源部のリングはクロムメッキと複数のファインテクスチャー(FT)です。

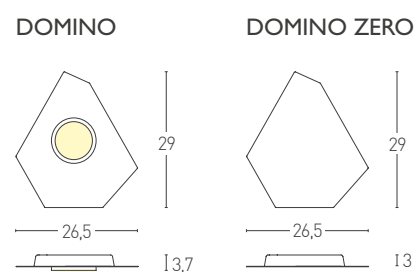
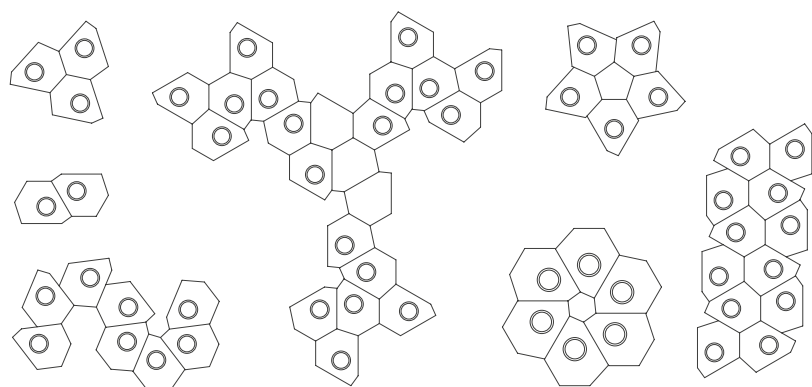

Units: cm



Finishes

Lamp body:

- 105 FT White (W)
- 138 Titanium (T)
- 126 FT Sage green (G)
- 115R Sand grey (S)
- 139 Cor-ten (N)
- 130 Gold foil (O)
- 131 Silver foil (A)

Ring:

- 105 FT White (W)
- 138 Titanium (T)
- 126 FT Sage green (G)
- 115R Sand grey (S)
- 139 Cor-ten (N)
- 119 Chartreuse green (H)
- 120 Red (R)
- 150 Chrome (C)
- 152 Satin Brass (B)

Diffuser

PMMA methacrylate diffuser
WIDE / MEDIUM / HONEY COMB

Electronic driver

Dimmable included TRIAC

Light source

LED

LED 1x5,8W 100/120V or 220/240V
2700K/3000K/4000K 690lm CRI>90

A

Certification

CE EAC PS E F IP20 Classe I



CONFIGURATOR CREATE YOUR OWN STYLE!

Visit lumencenteritalia.com

MODELLO Model	FINITURA BASE Basic finishing	FINITURA SUPERFICIE Cover finishing	FINITURA ANELLI Rings finishing
<input checked="" type="checkbox"/> BRICK Q1	<input checked="" type="checkbox"/> WHITE	<input checked="" type="checkbox"/> WHITE	<input type="checkbox"/> WHITE
BRICK Q4	TITANIUM	TITANIUM	TITANIUM
BRICK R2	SAGE GREEN	SAGE GREEN	SAGE GREEN
BRICK R4	SAND GREY	SAND GREY	SAND GREY
BRAC 1	COR-TEN	COR-TEN	COR-TEN
			<input checked="" type="checkbox"/> GREEN CHARTREUSE
BRAC 4		GOLD FOIL	GREEN CHARTREUSE
BRAC 6		SILVER FOIL	RED
BRAC 10			CHROME
DOMINO			SATIN BRASS
DOMINO ZERO			

OTTICA Optique	TEMPERATURA COLORE Colour Temperature	ALIMENTATORE Driver	ACCESSORIO Optional	ACCESSORIO Optional
<input checked="" type="checkbox"/> WIDE	2700 KELVIN	220/240 VOLT	SPEAKER BT 5V BATTERY BLUETOOTH SOUND CONTROL	OKKIO SPOT DIRECTIONABLE SPOTLIGHT 6W 100/120V OR 220/240V 3000K BEAM 36° SWIVEL VERTICALLY 45° ROTATE HORIZONTALLY 360°
<input checked="" type="checkbox"/> MEDIUM	3000 KELVIN	110/120 VOLT		
<input checked="" type="checkbox"/> HONEY COMB	4000 KELVIN			

Shape: BRICK QUADRO 4
 Basic finishing: TITANIUM
 Cover finishing: TITANIUM
 Ring: GREEN CHARTREUSE
 Optique: HONEY COMB
 Colour Temperature: 3000K
 Driver: 110/120V
 Optional: NO

CONFIGURA BRICK, BRAC, DOMINO

Crea la lampada e il sistema più adeguato e armonico attraverso il CONFIGURATORE, avendo la possibilità di scegliere tra forme, potenza luminosa, colori, finiture, temperatura colore della luce ed ottiche. Nuovi accessori come OKKIO SPOT, un faretto direzionabile con ottica di 36° e SPEAKER BT, una piccola cassa acustica bluetooth, fanno del CONFIGURATORE un'opzione per esprimere al meglio stile e personalità con infinite possibilità.

CONFIGURE BRICK, BRAC, DOMINO

Create your own lamp and most suitable system with the CONFIGURATOR, having the chance to choose between forms, lumen watts, colours, finishes, colour temperature and optics. New accessories as OKKIO SPOT, a directional spotlight with optic 36° and SPEAKER BT, a small Bluetooth speaker, make the CONFIGURATOR an option to best express style and personality in infinite ways.

カスタマイズ可能な BRICK, BRAC, DOMINO

種類、明るさ、色、仕上げ、色温度、配光角度をリストから選択することができ、お好みの照明を製作することができます。さらに、配光角36°のユニバーサルスポットライト(OCCHIO)、小型Bluetoothスピーカーも選択肢に加わりました。無数に広がる組み合わせの中から、あなたの個性をより表現する1品を製作してみませんか。

PUNTO

Design VillaTosca



PUNTO DI LUCE

Un punto in un punto di luce. Plafoniera di grande versatilità, richiama con i puntini luminosi che traspaiono dal diffusore le analisi di Fibonacci sulla disposizione dei semi di girasole.

POINT OF LIGHT

A point in a point of light. Ceiling lamp of great versatility, recalls, with bright shining dots, the Fibonacci analysis of sunflower seeds.

点の光

『ポイント』は点の光です。非常に汎用性の高いシーリングランプであり、発光面に浮かぶ小さな光の点はフィボナッチの法則に基づいた、ひまわりの種の配列を思わせます。

PUNTO / PUNTO P

Design VillaTosca

Le leggi della natura e quelle della matematica si incontrano in un corpo di luce essenziale e versatile. I delicati puntini luminosi che traspaiono dal diffusore riprendono l'affascinante spirale dei semi di girasole, di cui il matematico Fibonacci aveva colto il ritmo numerico. La forma a cerchio della plafoniera viene ripresa dal punto centrale. Più plafoniere disposte in libertà sbocciano sul soffitto come eleganti fiori geometrici.

Laws of nature and mathematics meet in an essential and versatile body of light. The soft light small spots that shine from the diffuser remind the fascinating spiral of sunflower seeds that the mathematician Fibonacci studied and discovered numerical rhythm behind it. The circle shape of the ceiling lamp is recalled in the central point. Several ceiling spots create on wall elegant geometric flowers shadows.

自然界の法則から導き出された数学の世界が照明の上に重なり合います。照明の発光面に浮かぶ光の点で作られる魅力的な幾何学模様、それは数学者フィボナッチによって定義つけられたひまわりの種の配列を模した螺旋模様です。中心の小さな点から照明本体の淵にあたる円までその螺旋は広がっていきます。天井に配置されたこのシーリングランプは天井にエレガントな幾何学模様の花を咲かせます。



PUNTO P

PUNTO

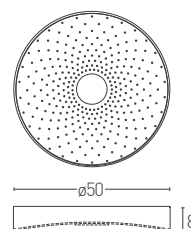
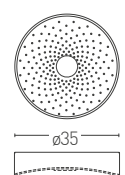

Units: cm

Finishes

- 105 FT White
- 115R FT Sand grey
- 125 FT Anthracite grey

Diffuser

PMMAD methacrylate diffuser

Electronic driver

Dimmable included TRIAC

Light source

LED

LED Total power
100/120V or 220/240V 3000K CRI>90
PUNTO P 21W 2700lm
PUNTO 33W 4300lm

Certification

CE EAC PS E F IP20 Classe I



FOLIAGE 2700

Design Enrico Azzimonti



EMOZIONI LUMINOSE

FOLIAGE 2700, applique disegnata da Enrico Azzimonti che si propone di riportare attraverso linee essenziali e giochi di luce indiretta le emozioni luminose che si provano standosene sdraiati sotto la chioma di un albero e osservandone le foglie.

BRIGHT EMOTIONS

FOLIAGE 2700, bracket lamp designed by Enrico Azzimonti aims to restore, through essential lines and games of indirect light, the same bright emotions felt lying under a tree foliage and watching its leaves.

光のエモーション

「フォリアージュ2700」はルーメンセンター・イタリアのためにエンリーコ・アズィモンティによってデザインされたLED光源を内蔵したランプのシリーズ。この優雅なラインでデザインされたランプは、樹木の下に横たわって木漏れ日を見上げた時に現れるような光の再現を目指して作られました。



FOLIAGE 2700 / FOLIAGE 2700 P

Design Enrico Azzimonti

FOLIAGE 2700, applique e plafoniera a sorgente LED disegnata da Enrico Azzimonti. È presentata in due misure combinabili a parete o soffitto. Disponibile nelle finiture bianco fine textured/bianco opaco, grigio sabbia fine textured/bianco opaco, Cor-Ten/bianco opaco. Sorgente luminosa LED da 2x6W 1200lm per la versione P da 38 cm e 4x6W 2400lm per la versione da 56 cm.

FOLIAGE 2700, wall and ceiling lamps with LED light sources designed by Enrico Azzimonti. Available in two sizes combinable as wall or ceiling lamps. Available colour combinations: fine textured white/matte white, fine textured sand grey/matt white, Cor-Ten/matt white. LED light source 2x6W 1200lm for the P version (38 cm) and 4x6W 2400lm for the 56 cm version.

「フォリアージュ2700」シリーズのウォール/シーリングランプ。ルーメンセンター・イタリアのためにエンリーコ・アッツイモンティによってデザインされたLED光源ランプ。二種類のサイズで壁/天井の両方に使用が可能です。塗装のコンビネーションは、梨地状のファインテクスチャー（以下FT）FTホワイト/ホワイト半光沢、FTサンド・グレー/ホワイト半光沢、FTコールドレン/ホワイト半光沢の3種類から選択できます。LED光源は2x6ワット、1200ルーメンが「フォリアージュP」のバージョンに、4x6ワット、2400ルーメンが「フォリアージュ」56cmのバージョンに内蔵されています。



FOLIAGE

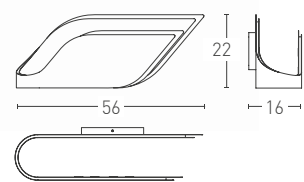

FOLIAGE P

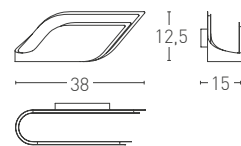

Units: cm



Finishes

- 105 FT + 106
Fine textured White and Matte white
- 115R FT + 106
Fine textured Sand grey and Matte white
- 139 + 106
Cor-Ten and Matte white

Electronic driver

Dimmable included TRIAC

Light source

LED

100/120V or 220/240V

FOLIAGE 2700

LED Total power 24W
2400lm 2700K CRI>90

FOLIAGE 2700 P

LED Total power 12W
1200lm 2700K CRI>90

A

Certification

CE EAC PS E F Classe I IP20



OUTLINE

Design Francesco Murano

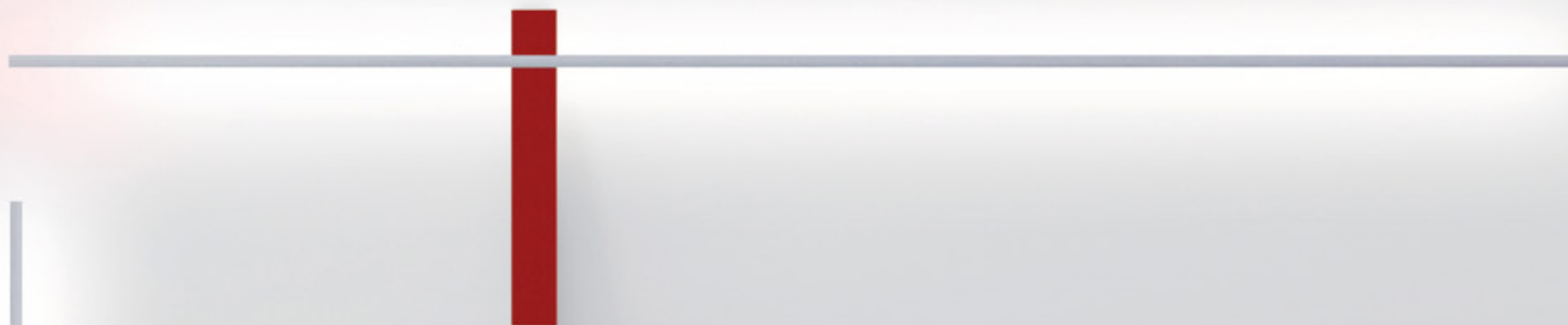

PROFILI DI LUCE

L'apparecchio luminoso è concepito come elemento compositivo della luce policroma proiettata sul muro.

La lampada e la luce diventano affresco luminescente nello spazio, segno grafico di forte impatto visivo, capace di caratterizzare la parete e l'ambiente.

LIGHT OUTLINES

The light device was created as composition element of the polychrome light projected onto the wall.

Lamp and light become a fresco in the space, graphic signal for a strong visual impact, able to characterize wall and setting itself.

グラフィック ライト サイン

この照明は様々な色の光を壁に映し出す照明器具として製作されました。

器具とその光は壁面においてフレスコ画のように映し出され、その強い視覚効果は壁面と器具自体に個性を生み出します。

OUTLINE

Design Francesco Murano

OUTLINE, sottile applique in alluminio con sorgenti LED integrate di altissima resa cromatica. Disponibile nelle versioni con luce all'estremità "Total White" e "Red Light".

OUTLINE, thin aluminum wall lamp with high colour rendering LED integrated. Available in version with tail light in "Total White" and "Red Light".

アウトラインは、非常に薄いアルミの棒で作られたウォールランプで、演色性の高いLED光源を搭載しています。

赤いLEDの光を放つ部分は、その赤い光の点と白光りするフレームの細い線から、まるでキャンドルがマッチに炎がともっているかのようなイメージを与えます。組み立ては簡単で、それは位置を決める際にも有効です。

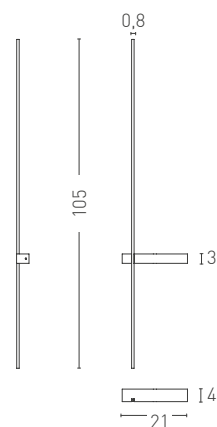

Units: cm

Finishes

- 103FT Black + 172 Natural anodized
- 105FT White + 172 Natural anodized
- 129FT Red + 172 Natural anodized

Electronic driver

Included ON/OFF

Light source

LED

LED 12W + 1W Red
50/60 Hz 220/240V 1560lm 3000K CRI>90

LED 12W + 1W Total white
50/60 Hz 220/240V 1560lm 3000K CRI>90

A

Certification

CE F IP20 Classe I

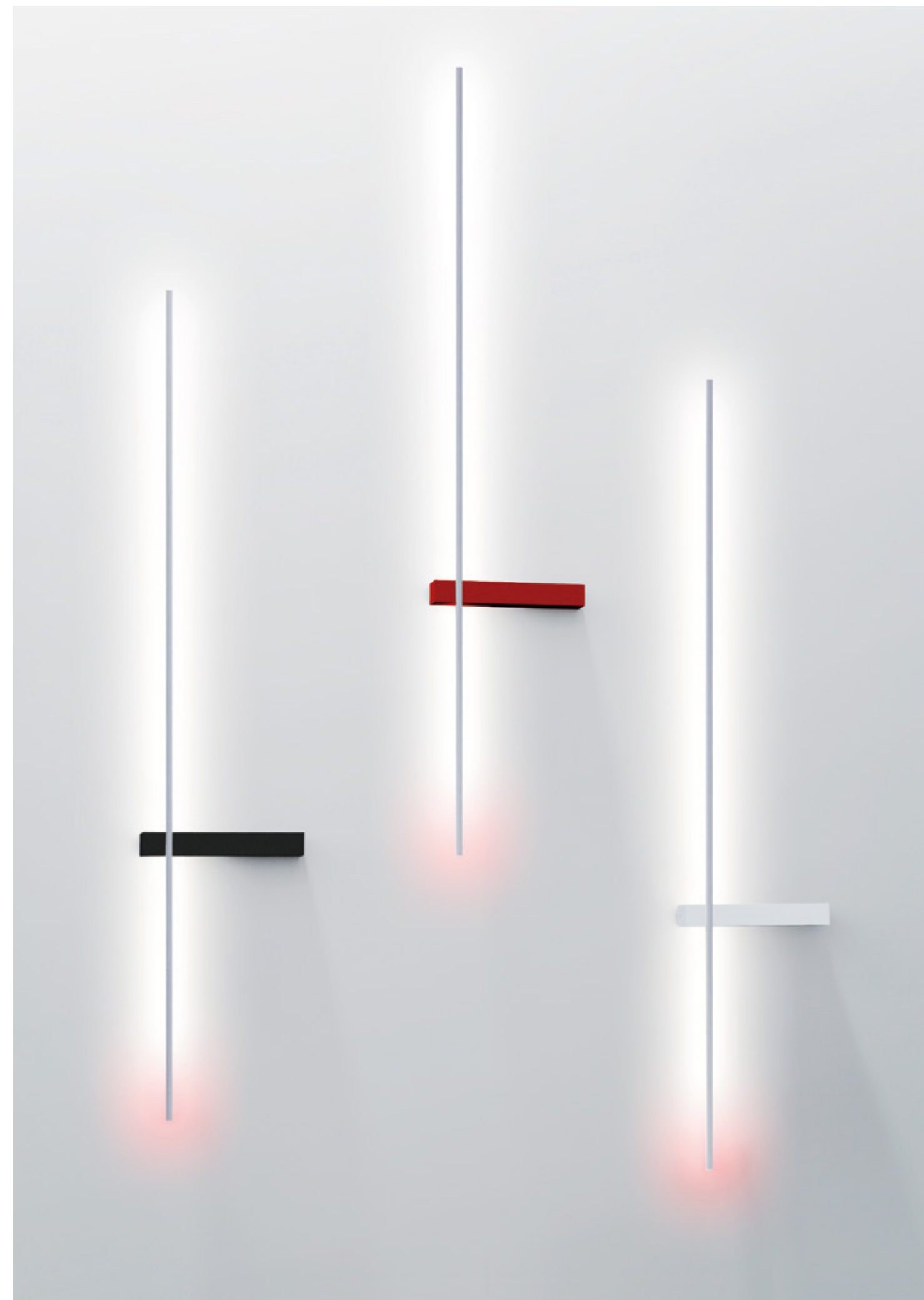



ALBA E TRAMONTO IN UNA NUOVA APPLIQUE

HINODE, applique a luce indiretta disegnata da Setsu&Shinobu Ito. La lampada, liberamente ispirata alla luce del giorno che sorge e tramonta sulla linea dell'orizzonte, illumina generosamente verso l'alto e diffonde, attraverso una fessura nel corpo lampada, una morbida luce verso il basso.

SUNSHINE AND SUNSET IN A NEW WALL LAMP

HINODE an indirect light wall lamp designed by Setsu&Shinobu Ito. The lamp, inspired by the daylight that rises and sets on the horizon line, lights generously upwards and spreads a soft light downwards through a slot in the lamp structure.

日の出と夕暮れを 新しいウォールランプに

「日の出」は、ルーメンセンター・イタリアのため伊藤節と伊藤しのぶによってデザインされたウォールタイプの間接照明です。地平線から日が昇り、そして日が沈む様子をイメージして製作されました。光が惜しみなく上向きに放射されるとともに、ランプ構造の隙間からやわらかく下方に広がります。

HINODE

Design Setsu&Shinobu Ito

HINODE, applique in alluminio pressofuso con sorgente LED o alogena ECO Energy Saver, disegnata da Setsu&Shinobu Ito. Disponibile nelle finiture: bianco opaco, alluminio sabbato e grigio perla.

HINODE is a wall lamp in die cast aluminum with LED or ECO halogen light source, designed by Setsu&Shinobu Ito. Available in the following finishes: matte white, sandblasted aluminum or pearl grey.

「日の出」はアルミダイキャスト成型にLEDまたはエナジーセーバー・エコハロゲンの光源を持つ、ウォールタイプのランプです。ルーメンセンター・イタリアのため伊藤節+伊藤しのぶがデザインしました。ホワイト半光沢、アルミ・サンドブラスト仕上げ、パール・グレイの塗装から選択できます。

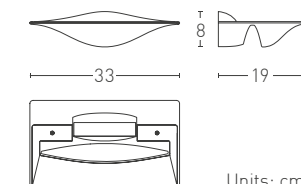
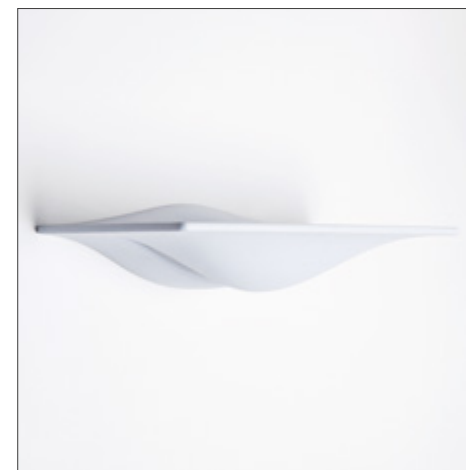

Units: cm

Finishes

- 106 Matte white
- 121 Sandblasted aluminum
- 123 Pearl grey

Electronic driver

HINODE LED Dimmable included TRIAC

Suggested light source

HINODE  100/240V
R7s Linear Halogen ECO 114,2 mm
max 1x230W

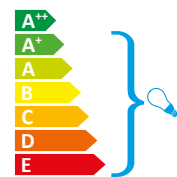

Light source

LED

HINODE LED 100/120V or 220/240V

LED Total power 42W
3850lm 3000K CRI>90

A

Certification

CE EAC   Classe I IP20



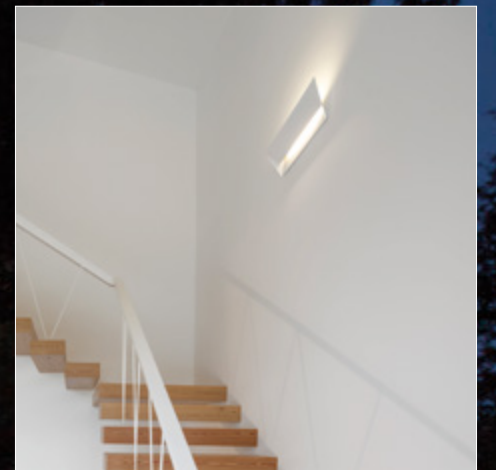
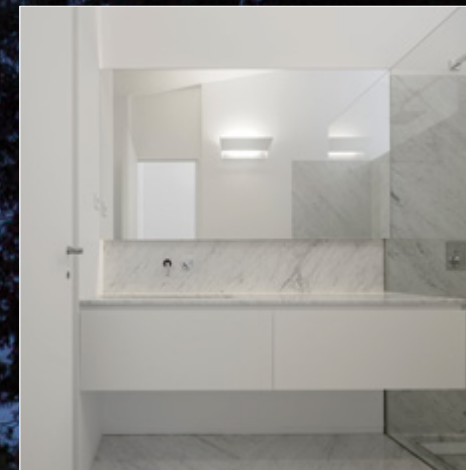
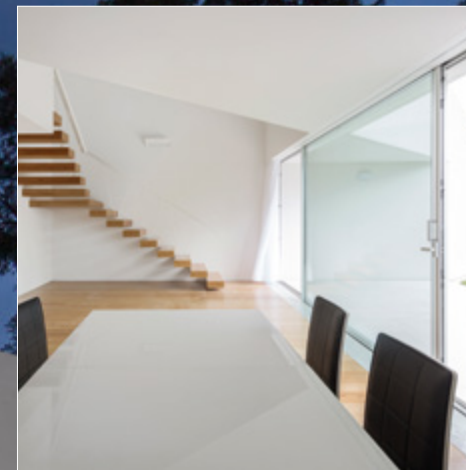
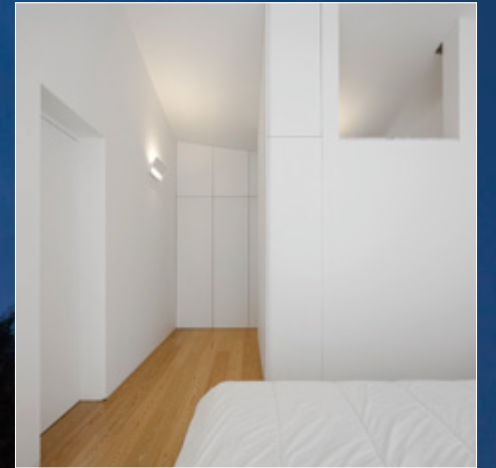
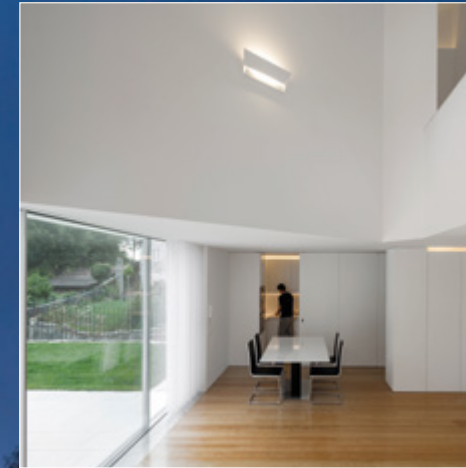
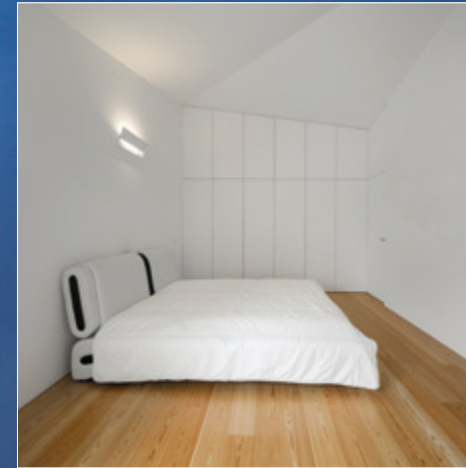

IRONIA E SEMPLICITÀ

MAIL, serie di applique disegnate da Alberto Saggia e Valerio Sommella, è protagonista dell'illuminazione di Casa Taíde - l'innovativo progetto degli architetti Rui Vieira Oliveira e Vasco Manuel Fernandez realizzato a Taíde, Póvoa de Lahnoso (Portogallo) e vincitore dei premi Architizer: A+ Award 2015 Jury Winner e A+ Awards 2015 Popular Choice Winner.

IRONY AND SIMPLICITY

Mail, wall lamp series designed by Alberto Saggia and Valerio Sommella, is protagonist of Casa Taíde illumination - an innovative project by the architects Rui Vieira Oliveira and Vasco Manuel Fernandez realized in Taíde, Póvoa de Lahnoso (Portugal) and winner of Architizer awards: A+ Award 2015 Jury Winner e A+ Awards 2015 Popular Choice Winner.

アイロニーとシンプルさ

「メール」は、アルベルト・サジヤとヴァレリーオ・ソーンメッラによってデザインされたウォールタイプのランプ。このランプは、アメリカの建築・デザインWEBサイト「アルキタイザー(Architizer)」主催の「A+Awards」賞で審査員賞およびポピュラーチョイス賞の二つを受賞したプロジェクト「タイデ邸 (Taíde House)」(設計: ルイ・ヴィエーラ・オリヴィエーラ+ヴァスコ・マヌエル・フェルナンデス/ポルトガル)に使用されました。

MAIL / MAIL S

Design Alberto Saggia+Valerio Sommella

MAIL è l'ironica collezione di applique disegnata da Alberto Saggia e Valerio Sommella. In queste pagine viene presentata nella versione "regular" (l 34 cm) e "small" (l 19 cm). Entrambe forniscono luce indiretta attraverso una sorgente LED o alogena ECO Energy Saver. MAIL e MAIL S sono disponibili in cinque diverse finiture: bianco opaco, grigio sabbia FT, grigio perla, foglia oro e foglia rame.

MAIL is the ironic collection of wall lamps designed by Alberto Saggia and Valerio Sommella. In these pages it is presented in its "regular" (l 34 cm) and "small" (l 19 cm) versions. They both produce indirect light using a LED system or an ECO Energy Saver halogen light source. MAIL and MAIL S are available in five different finishes: matte white, sand grey FT, pearl grey, gold foil and copper foil.

「メール」は、アルベルト・サッジャとヴァレリオ・ソンメッラがルーメンセンター・イタリアのためにデザインしたシニカルな作品。このページでは、レギュラーサイズ（幅34 cm）とスモールサイズ（幅19 cm）の製品を紹介します。両方ともLED光源とエコハロゲン・エナジーセーバーのランプの二種類を取り揃えています。「メール」と「メールS」は、以下の五種類の塗装から選ぶことができます。ホワイト半光沢、サンド・グレーFT、パール・グレー、金箔仕上げ、銅箔仕上げ。

MAIL S

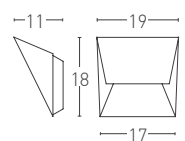

MAIL

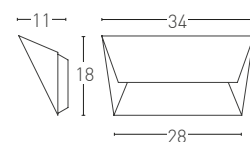

Units: cm

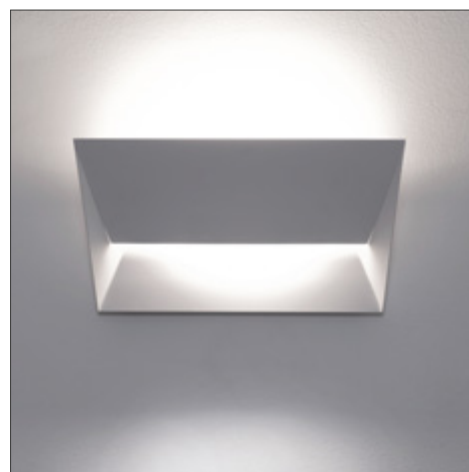

Finishes

- 106 Matte white
- 115R FT Sand grey
- 123 Pearl grey
- 130 Gold foil
- 132 Copper foil

Electronic driver

MAIL S LED Drive included
MAIL LED Dimmable driver included TRIAC

Light source LED

MAIL S LED 220/240V
LED 9,2W 780lm 3000K CRI>90
MAIL LED 100/120V or 220/240V
LED 25W 2320lm 3000K CRI>90

A

Suggested light source

100/240V

MAIL S G9 Halogen ECO
max 1x60W

MAIL R7s Linear Halogen ECO 114,2 mm
max 1x230W

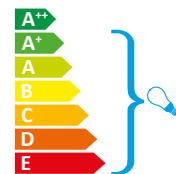

Certification

CE ENEC PS E IP20 Classe I



MAIL L/XL

Design Alberto Saggia+Valerio Sommella

MAIL L e XL nella versione "large" (l 56 cm) e "extra large" (l 81 cm). Utilizzano sorgenti LED o fluorescenti ECO Energy Saver.

Disponibili in cinque diverse finiture: bianco opaco, grigio sabbia FT, grigio perla, foglia oro e foglia rame.

MAIL L and XL in "large" (l 56 cm) and "extra large" (l 81 cm) versions with embedded LED or Ecofluor light source.

Available in five different finishes: matte white, sand grey FT, pearl grey, gold foil and copper foil.

「メールL」と「メールXL」は、ラージサイズ（幅56 cm）とエクストラ・ラージサイズ（幅81 cm）の製品です。両方ともLED光源とエコハロゲン・エナジーセーバーのランプの二種類を取り揃えています。以下の五種類の塗装から選ぶことができます。ホワイト半光沢、サンド・グレーFT、パール・グレー、金箔仕上げ、銅箔仕上げ。

MAIL L

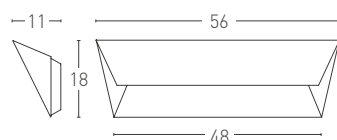

MAIL XL

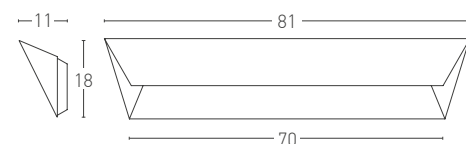

Units: cm



Finishes

- 106 Matte white
- 115R FT Sand grey
- 123 Pearl grey
- 130 Gold foil
- 132 Copper foil

Electronic driver

Included for LED version only:
Dimmable TOUCH DIM, DALI

Light source LED

MAIL L LED
LED Total power 40W 220/240V
3765lm 3000K CRI>90

MAIL XL LED
LED Total power 60W 220/240V
5650lm 3000K CRI>90



Light source



MAIL L
ECO Fluor 2G11 220/240V
1x24W 1800lm 3000K **AL.EL.**

MAIL XL
ECO Fluor 2G11 220/240V
1x55W 4800lm 3000K **AL.EL.**



Certification

CE ENEC IP20 Classe I





UN CONCENTRATO DI LUCE

SEGNI, famiglia di punti luce a parete caratterizzati dal design estremamente minimale, progettata per ottenere il miglior rendimento luminoso con il minore ingombro e utilizzo di materiale possibile. Il risultato è un concentrato di luce in cui il corpo lampada sparisce sulla parete per dare risalto alle potenzialità dei LED utilizzati. Nuove le versioni orientabili e con doppia sorgente LED (3000K CRI>90).

A CONCENTRATION OF LIGHT

Segni, collection of wall spot lights characterized by an extremely minimal shape, is designed to get the best light output in the smallest amount of space possible. The outcome is a concentrate of light where the lamp body disappears and LED technology stands out. New adjustable versions and with double LED light source (3000K CRI>90).

光の結晶

「セーニ」は、ミニマルデザインの極限を再現したウォールランプでのシリーズ、必要最小限のサイズと材料の消費で最大限の効果を発揮できる照明を目指してデザインされました。その結果としてLED光源(3000ケルビン、CRI>90)の性能を光の結晶として最大限に活用することでランプ自体がまるで壁に溶け込んでしまった様な印象を創り出すことが出来ました。シリーズには新たに照射角度自在式タイプと上下二重光源内蔵タイプが加わりました。

SEGNI QUADRO/RETTO/TONDO

Design VillaTosca

SEGNI è la collezione di piccoli punti luce a parete che esalta le potenzialità dei LED utilizzati, rendendo minimo l'ingombro e l'utilizzo di materiale del corpo lampada. Disponibili nelle finiture: bianco fine textured, nero fine textured. Utilizzano sorgenti LED da 10W, 3000K e resa luminosa da 780lm.

SEGNI is the collection of small wall spot lights, that emphasizes the potential of the LED used, in a minimum amount of space and with the smallest use of materials for the lamp body. Available in the following finishes: white fine textured, black fine textured. LED light source 10W 3000K, 780lm.

「セーニ」は、ミニマルデザインの極限を再現したウォールランプで、必要最小限のサイズと材料の消費で最大限の効果を発揮できる照明を目指してデザインされました。塗装は、梨地状のファインテクスチャー(以下FT)仕上げで、FTホワイト、FTブラックが用意されています。

LEDは10ワット、3000ケルビン、780ルーメン。

SEGNO QUADRO

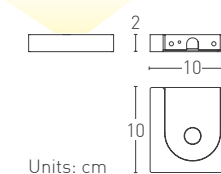

SEGNO TONDO

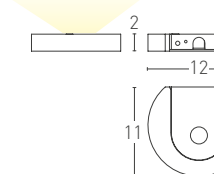

SEGNO RETTO

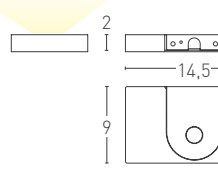

Units: cm



Finishes

- 103 FT Black
- 105 FT White

Electronic driver

LED Light Engine dimmable TRIAC

Light source LED

LED 10W 100/120V or 220/240V
780lm 3000K CRI>90



Certification

CE ENEC PS E F Classe I IP20

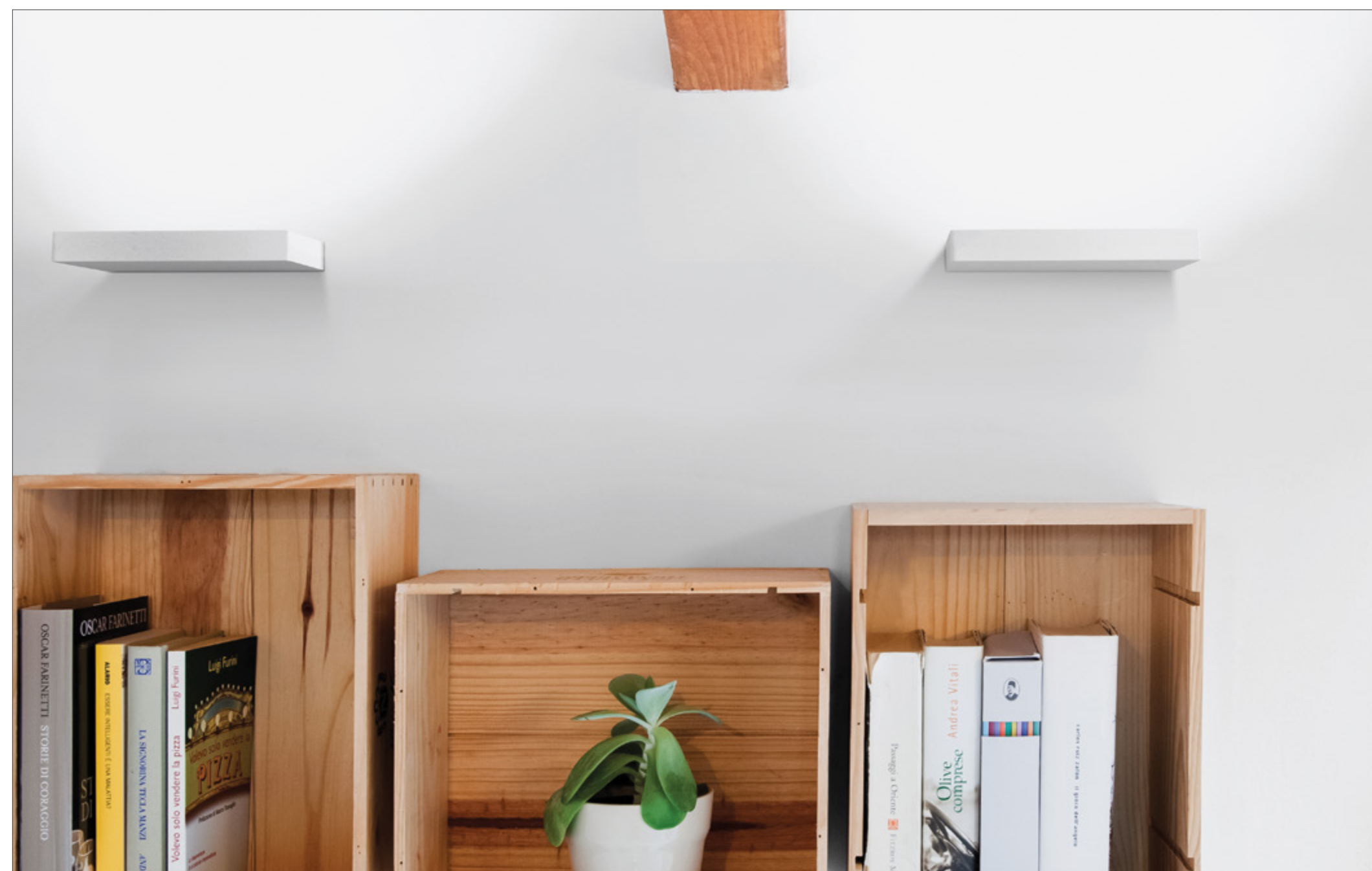

SEGNI MAXI QUADRO/RETTO/DOUBLE

Design VillaTosca

Punti luce a parete dall'elevata potenza luminosa. Disponibili nelle finiture Bianco Fine Textured (FT) e Nero Fine Textured (FT). Sorgente LED da 20W, 3000K, 1560lm, CRI>90. Disponibile anche nella versione MAXI DOUBLE con doppia sorgente luminosa collocata nella parte superiore e inferiore del corpo lampada.

High luminous intensity wall spot lights. Available in the following finishes: White Fine Textured (FT) and Black Fine Textured (FT). LED light source 20W, 3000K, 1560lm CRI>90. The MAXI DOUBLE version has double light source located both in the upper and lower part of the lamp body.

強力的な光を生むウォールタイプのポイントライト。塗装は梨地状のファインテクスチャー(以下FT)仕上げでFTホワイト、FTブラックが用意されています。LEDは20ワット、3000ケルビン、1560ルーメン、CRI>90。「マキシ・ダブル」のバージョンは二重光源を持ち上部と下部を同時に照らすことができます。



Finishes

- 103 FT Black
- 105 FT White

Electronic driver

LED Light Engine dimmable TRIAC

Light source LED

LED 20W 100/120V or 220/240V

SEGNO MAXI QUADRO
1560lm 3000K CRI>90

SEGNO MAXI RETTO
1560lm 3000K CRI>90

SEGNO MAXI DOUBLE

LED Up: 20W 1560lm 3000K CRI>90

LED Down: 10W 780lm 3000K CRI>90



Certification

CE ENEC PS E F Classe I IP20

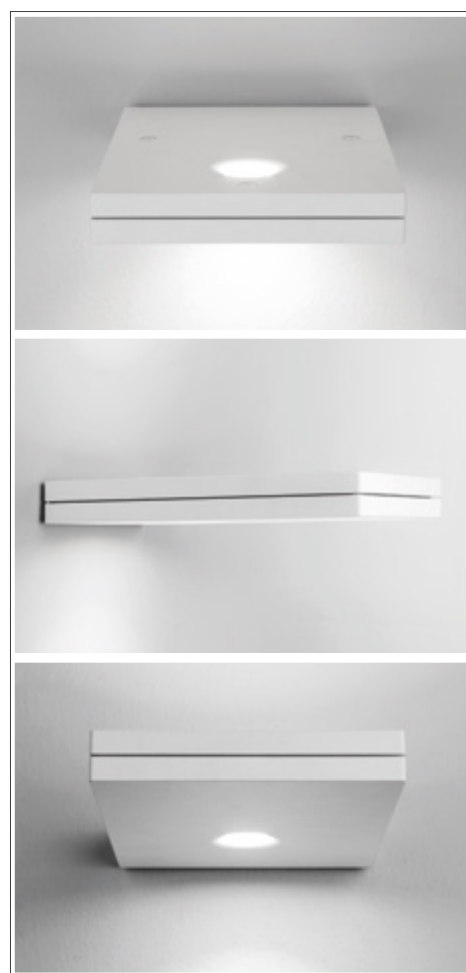

SEGNO MAXI QUADRO

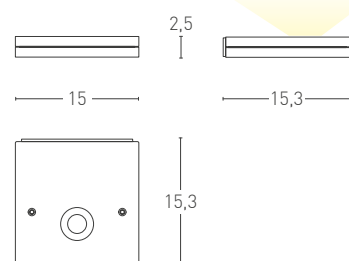

SEGNO MAXI RETTO

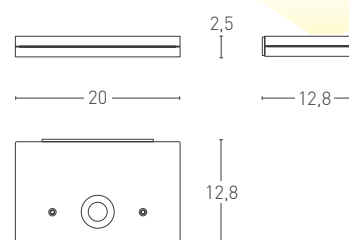

SEGNO MAXI DOUBLE

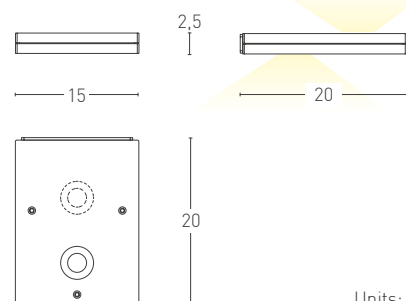

Units: cm



VIRGOLA

Design VillaTosca



STILE MINIMAL,
LUCE AL MASSIMO

VIRGOLA, applique caratterizzata dal design estremamente minimale: la lampada é infatti concepita per ottenere il miglior rendimento luminoso con il minore ingombro e utilizzo di materiale.

MINIMAL DESIGN,
MAXIMUM LIGHT PERFORMANCE.

VIRGOLA, wall lamp characterized by an extremely minimal design: the lamp is in fact designed to obtain the best illumination result in a minimum amount of space and with the smallest use of materials.

ミニマル・スタイル
最大の光

「ヴィルゴラ」は、ウォールタイプの間接照明ランプです。究極のミニマル・デザインを特徴とする製品で、最低限の大きさと最小限のマテリアルの消費によって最大の光効率を実現するべくデザインされました。

VIRGOLA

Design VillaTosca

VIRGOLA, lampada da parete a luce indiretta. Il design estremamente minimal che caratterizza il prodotto, consente la massima resa della tecnologia LED utilizzata. Disponibile con sorgente LED da 20W e 1560lm. Finiture: Bianco Fine Textured (FT), Grigio Sabbia Fine Textured (FT) e Cor-Ten.

VIRGOLA, indirect light wall lamp. The extremely minimal design that characterizes the product allows the maximum exploitation of the LED technology used. Available with LED light source 20W and 1560lm. Finishes: White Fine Textured (FT), Sand Grey Fine Textured (FT) and Cor-Ten.

「ヴィルゴラ」は、ウォールタイプの間接照明ランプです。究極のミニマル・デザインを特徴とする製品で、使われているLED光源技術が与えるその効果は製品のコンセプトに大きく貢献しています。LED光源は、20ワット/1560ルーメン。塗装は、ファイン・テクスチャー塗装 (FT) : ホワイト、サンド・グレー、コールテンの3種類が用意されています。

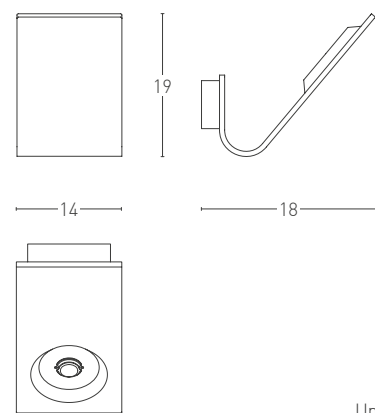

Finishes

- 105 FT White
- 115R FT Sand grey
- 139 Cor-Ten

Electronic driver

LED Dimmable TRIAC

Light source

LED

LED 20W 100/120V or 220/240V
1560lm 3000K CRI>90

A

Certification

CE EAC PS E F Classe I IP20

Units: cm





PUNTI DI LUCE

PINCO&PALLINO, collezione di illuminazione puntuale a sorgente LED. PINCO e PALLINO diventano la sorgente luminosa ideale per illuminare piccoli spazi, per fare luce su banconi e penisole, oppure come punto luce in serie a soffitto e parete. Ogni prodotto è presentato nelle versioni applique, sospensione e nelle versioni applique e sospensione da incasso per renderne più agevole l'installazione in abbassamenti, contropareti e soffitti.

POINTS OF LIGHT

PINCO&PALLINO, line of spot lights using LED light source. PINCO and PALLINO are the ideal light source to light up small spaces, to provide light on counters and peninsulas, or as an in-line light source on ceiling or wall. Each product is presented in the following versions: wall lamp, suspension and in their built-in versions, suitable for lowerings, double walls and ceilings.

点のひかり

「ピンコ&パल्लीノ」はLEDを光源に持つポイントライトシリーズです。限られた空間のカウンターや長テーブルを照らす為の理想的な照明ですが、スポット/アクセントライトとして天井や壁に使用するにも最適です。各デザインにウォール/シーリング/ペンダント、タイプを用意しており、埋め込みタイプのモデルは壁や天井の穴に簡単に設置できるバイオネット式の取り付け金具を有しています。

PINCO 21/21-I/S/S-I

Design VillaTosca

PINCO 21 e PINCO 21-I, piccoli punti luce da parete o soffitto. La versione 21 è dotata di alimentatore integrato nella base, mentre, la versione 21-I da incasso, può essere fornita con diversi alimentatori remoti a seconda del numero di lampade installate.

PINCO S e PINCO S-I, punti luce a sospensione disponibili anche nella versione ad incasso. Diffusore realizzato in metacrilato trasparente. Sorgente luminosa LED da 4,5W 430lm, 3000K, CRI>90. Finiture disponibili: bianco opaco, nero opaco e cromato.

PINCO 21 and PINCO 21-I are small wall or ceiling spot lights. The 21 version is equipped with an electronic driver integrated into the base, while the 21-I recessed lighting version can be provided with different remote electronic drivers according to the number of lamps installed.

PINCO S and PINCO S-I are pendant spot lights also available in recessed lighting. Diffuser in transparent methacrylate. LED light source of 4,5W 430lm, 3000K, CRI>90. Finishes: matte white, matte black and chrome.

「ピンコ21&ピンコ21-I」は壁や天井に設置する小さなポイントライトです。バージョン「21」はドライバー内蔵型、バージョン「21-I」は埋め込み型でドライバーは必要な照明の数にあわせて別置で設定ができます。

「ピンコS&ピンコS-I」はペンダントタイプのポイントランプで、埋め込み型も用意しています。発光部は透明のメタクリレート樹脂製。光源はLED(4.5ワット、430ルーメン、3000ケルビン、CRI>90)。筐体の仕上げは、ホワイト半光沢、ブラック半光沢、クロムメッキ。

PINCO 21

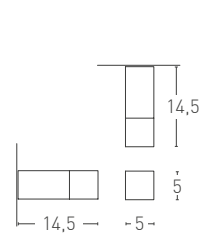

PINCO 21-I

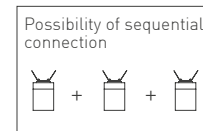
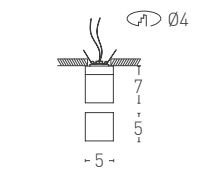

Units: cm

PINCO S

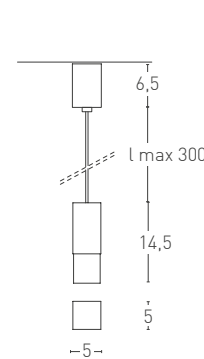

PINCO S-I

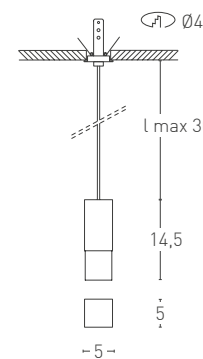

Finishes

- 102 Matte black
- 106 Matte white
- 150 Chrome

Diffuser

PMMA transparent methacrylate

Cable

PINCO S / PINCO S-I
Transparent

Electronic driver

PINCO 21 / PINCO S / PINCO S-I
Included
PINCO 21-I
Not included (250mA 20V)

Light source LED

LED 1x4,5W 100/240V
430lm 3000K CRI>90



Certification

CE ENEC PS E F IP20 Classe I

PINCO 21-I



PALLINO 21/21-I/S/S-I

Design VillaTosca

PALLINO 21 e PALLINO 21-I, piccoli punti luce da parete o soffitto. La versione 21 è dotata di alimentatore integrato nella base, mentre, la versione 21-I da incasso, può essere fornita con diversi alimentatori remoti a seconda del numero di lampade installate.

PALLINO S e PALLINO S-I, punti luce a sospensione disponibili anche nella versione ad incasso. Diffusore realizzato in metacrilato trasparente. Sorgente luminosa LED da 4,5W 430lm, 3000K, CRI>90. Finiture disponibili: bianco opaco, nero opaco e cromato.

PALLINO 21 and PALLINO 21-I are small wall or ceiling spot lights. The 21 version is equipped with an electronic driver integrated into the base, while the 21-I recessed lighting version can be provided with different remote electronic drivers according to the number of lamps installed.

PALLINO S and PALLINO S-I are pendant spot lights also available in lighting version. Diffuser in transparent methacrylate. LED light source of 4,5W 430lm, 3000K, CRI>90. Finishes: matte white, matte black and chrome.

「パッリーノ21&パッリーノ21-I」は壁や天井に設置する小さなポイントライトです。バージョン「21」はドライバー内蔵型、バージョン「21-I」は埋め込み型でドライバーは必要な照明の数にあわせて別置で設定ができます。

「パッリーノS&パッリーノS-I」はペンダントタイプのポイントランプで、埋め込み型も用意しています。発光部は透明のメタクリレート樹脂製。光源はLED(4,5ワット、430ルーメン、3000ケルビン、CRI>90)。筐体の仕上げは、ホワイต์半光沢、ブラック半光沢、クロムメッキ。

PALLINO 21

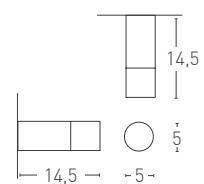

PALLINO 21-I

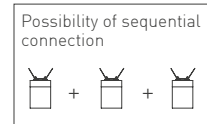
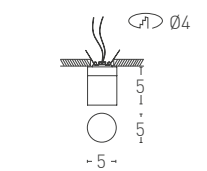

Units: cm

PALLINO S

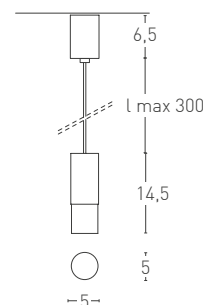

PALLINO S-I

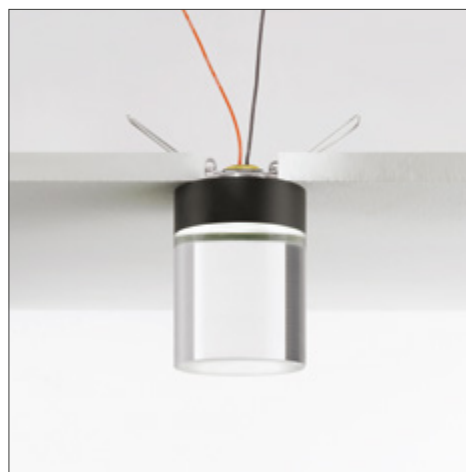
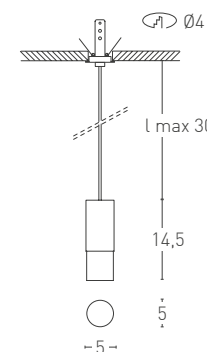

Finishes

- 102 Matte black
- 106 Matte white
- 150 Chrome

Diffuser

PMMA Transparent methacrylate

Cable

PALLINO S / PALLINO S-I
Transparent

Electronic driver

PALLINO 21 / PALLINO S / PALLINO S-I
Included

PALLINO 21-I
Not included (250mA 20V)

Light source LED

LED 1x4,5W 100/240V
430lm 3000K CRI>90



Certification



PALLINO 21-I



IP20 Classe I





L'ELEGANZA DEL LUSSO

All'apparente semplicità della linea, LUXOLINE associa la ricercatezza delle lavorazioni metalliche e delle finiture in cuoio esprimendo al meglio il magnifico connubio tra l'estetica, le forme e la funzione.

ELEGANCE OF LUXURY

Opposed to an apparent simplicity of its lines, LUXOLINE combines sophistication of its materials together with its leather finishes, gathering the interesting bond between aesthetics, forms and function.

こころに届く一筋の光

LIGHTINGの分野は技術の革新と共に“光”をミニマルで無垢な存在へ進化させています。一方でプリミティブでありながら確かな品質を継承し続けているのが工芸の分野です。照明を“装置”から“道具”へという想いの元この2つの世界、いわば「テクノロジー」と「クラフトマンシップ」の掛け合わせによりLUXOLINE「一筋の光」という照明が誕生しました。

LUXOLINE

Design LINE INC.

Sospensione lineare con struttura esterna in ottone bronzato o nickel satinato e con rivestimento in cuoio naturale e in pelle nera con cuciture sui bordi.

Le sorgenti LED con indice di resa cromatica superiore e diffusore in metacrilato rendono uniforme il flusso luminoso. L'alimentatore, alloggiato all'interno del corpo lampada, consente un facile controllo della intensità luminosa tramite il sistema di regolazione PUSH. Altezza disponibile su richiesta fino a 200cm.

Linear suspension in bronzed brass or satin nickel and stitched cover in natural leather or black leather.

LED light sources with high color rendering index and PMMA diffuser uniform to give a clean and powerful light. The driver, embedded in the lamp body allows a simple control of the intensity thanks to dimming system PUSH.

Upon request 200cm height available.

細長い光源を持つペンダントランプです。

色はサテンプラス+ナチュラルレザーとサテンニッケル+ブラックレザーの2種類で、皮革部分の淵にはアクセントのステッチが入ります。

演色効果の高いLED光源はメタクリレート樹脂製の拡散光板を通し均一な光を照射します。

照明本体に内蔵された電源装置はPUSH制御システムを介して好きな明るさに調光が可能です。

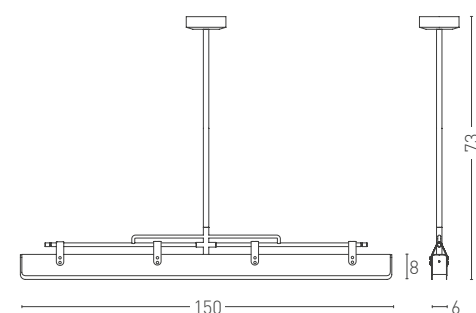

Units: cm



Finishes

- 152 Satin Brass + CN Natural Leather
- 166 Satin Nickel + CB Black Leather

Diffuser

PMMA methacrylate diffuser

Electronic driver

Dimmable included PUSH

Light source

LED

LED Total power
100/240V 30W 3900lm 3000K CRI>90



Certification

CE PS E F IP20 Classe I



LUXOLINE A/V

Design LINE INC.

Nelle versioni applique orizzontale e verticale, LUXOLINE A/V è disponibile con le stesse finiture della versione sospensione. Le sorgenti LED con indice di resa cromatica superiore e diffusore in metacrilato rendono uniforme il flusso luminoso. L'alimentatore, alloggiato all'interno del corpo lampada, consente un facile controllo della intensità luminosa tramite il sistema di regolazione PUSH.

In the horizontal and vertical wall lamp versions, LUXOLINE A/V is available in the same finishes of the suspension. LED light sources with high color rendering index and PMMA diffuser uniform to give a clean and powerful light. The driver, embedded in the lamp body allows a simple control of the intensity thanks to dimming system PUSH.

LUXOLINE · A/Vは横向きと縦向きのウォールタイプの照明でペンダントタイプと同じ仕上げになります。演色効果の高いLED光源はメタクリレート樹脂製の拡散光板を通し均一な光を照射します。照明本体に内蔵された電源装置はPUSH制御システムを介してお好きな明るさに調光が可能です。

LUXOLINEA

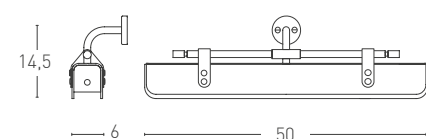

Units: cm

LUXOLINEV

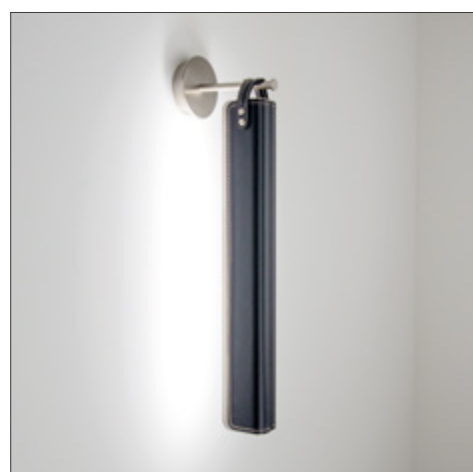
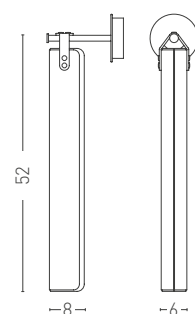

Finishes

- 152 Satin Brass + CN Natural Leather
- 166 Satin Nickel + CB Black Leather

Diffuser

PMMA methacrylate diffuser

Electronic driver

Dimmable included PUSH

Light source

LED

LED Total power
100/240V 9W 1170lm 3000K CRI>90

A

Certification

CE PS E F IP20 Classe I



PLANETS

Design JAMO Associates



LA PERFEZIONE SFERICA

La perfezione sferica come archetipo dei pianeti. PLANETS si ispira ed ispira il loro fascino e la loro sempiterna capacità attrattiva.

THE SPHERICAL PERFECTION

The spherical perfection as planets' archetype. PLANETS is inspired and inspires their outstanding attractiveness and their everlasting allure.

自然界の究極形

自然界の究極形。星、惑星など実際に自然界で浮遊するカタチ「球形」を使うことで、上にあることへの違和感を排除し、存在感を担保しながらもよりスムーズに空間になじみます。

PLANETS

Design JAMO Associates

La perfezione sferica come archetipo dei pianeti. PLANETS si ispira ed ispira il loro fascino e la loro sempiterna capacità attrattiva. Sospensione in ottone bronzato e sfere in PE speciale, donando lucidità e trasparenza come il vetro. Altezza disponibile su richiesta fino a 200cm.

The spherical perfection as planets' archetype. PLANETS is inspired and inspires their outstanding attractiveness and their everlasting allure. Suspension lamp in bronzed brass and shades in special high quality PE, giving a glossy and transparent finish as glass. Upon request 200cm height available.

球体のセードをぶどうの房のように立体的に形成することで、どの角度から見ても美しいシルエットで空間を照らします。洗練されたクラシックな空間からシンプルモダンな空間まで、さまざまなスタイルで圧倒的な存在感を発揮します。素材はブロンズブラスのフレームにガラスの様な光沢と透明性を持った特殊PE製の球型セード。

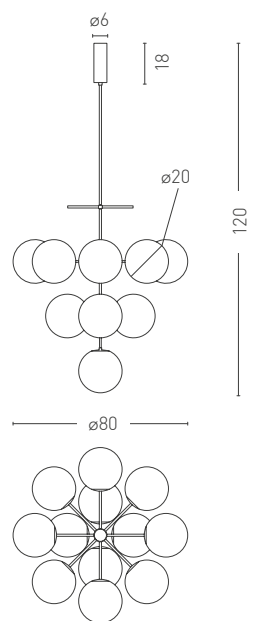

Units: cm



Finishes

● 156 Bronzed brass

Diffuser

Polyethylene glossy white

Suggested light source

220/240V E14

100/120V E12

 Halogen ECO max 13x30W

 LED 8W OPALE

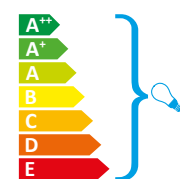

Certification

   IP20 Classe I



FREEDOM

Design Enrico Azzimonti

CANDELIERE IN CHIAVE MODERNA A MODERN CHANDELIER

Ispirata dalla percezione di circolarità della luce generata dalla fiamma di una candela in cui forma, colore, luce e calore sembrano essere magicamente racchiusi su loro stessi per poi aprirsi rischiando il buio e donando benessere, nasce FREEDOM - design Enrico Azzimonti - una rivisitazione contemporanea del candeliere.

Inspired by light circularity perception created by a candle flame where shape, color, light and heat seem to be magically enclosed in themselves waiting to be opened, enlightening and giving wellness, arise FREEDOM - design Enrico Azzimonti - a contemporary re-edition of the chandelier.

感情と感覚を開放するあかり

キャンドルの炎によって円形に拡散するあかりが生まれるフォルム、カラー、光、暖かさのそれらの感覚からインスピレーションを受け、この感覚の特徴を魅惑的に封じ込み、闇を照らしながらもその快適さを与えるそんな発想から「フリーダム」は生まれました。エンリーコ・アズィモンティのデザインによる現代版のシャンデリア・デザインを目指した、ペンダントタイプのランプです。

FREEDOM 10L/16L

Design Enrico Azzimonti



FREEDOM lampadario a sospensione disegnato da Enrico Azzimonti. Caratterizzato dalla semplicità delle linee, è disponibile nelle versioni a 10 o 16 luci. Finiture disponibili: nichel nero e bianco opaco.

FREEDOM chandelier designed by Enrico Azzimonti. Characterized by the simplicity of the lines, the lamp is available with 10 or 16 lights. Finishes available: black nickel and matte white.

「フリーダム」は、ルーメンセンター・イタリアのためにエンリーコ・アズィモンティによってデザインされたシャンデリアタイプのランプ。シンプルなラインが特徴です。このシャンデリアは、10灯、16灯の二種類が用意されています。塗装はニッケル・ブラックとホワイト半光沢の二種類が用意されています。



Finishes

- 106 Matte white
- 157 Black nickel

Suggested light source

220/240V E14
100/120V E12

- Halogen ECO
- FREEDOM 10L max 10x46W**
- FREEDOM 16L max 16x46W**

LED

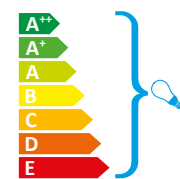

Certification

CE EAC PS E F Classe I IP20

FREEDOM 10L

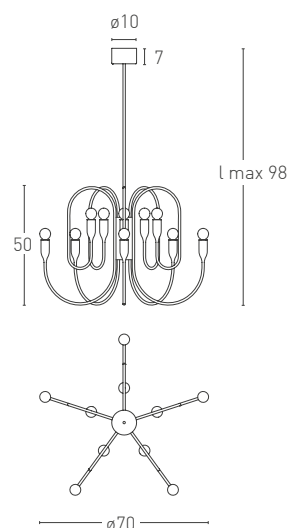

FREEDOM 16L

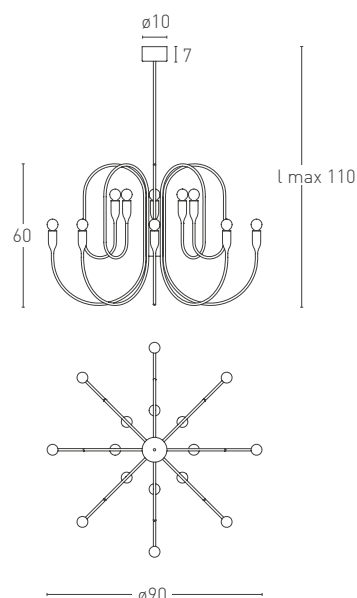

Units: cm



FLAT COLLECTION

Design VillaTosca



UN SOTTILE STRATO DI LUCE

FLAT è il sistema di illuminazione disegnato da VillaTosca. Il progetto condensa al minimo la superficie del corpo lampada con notevoli vantaggi in termini di leggerezza e riduzione degli ingombri. Le sorgenti LED utilizzate forniscono luce diretta verso il basso mentre lo strato di metacrilato la diffonde in maniera diffusa nell'ambiente.

A THIN LAYER OF LIGHT

FLAT is the lighting system designed by VillaTosca. The project condenses to a minimum the surface of the lamp body with considerable advantages in terms of lightness and space reduction. The LED light sources used provide direct light downwards while the layer of methacrylate spreads diffusely into the environment.

薄い光のレイヤー

「フラット」は、ヴィットラトスカによってデザインされたルーメンセンター・イタリアの新しい照明システムです。この製品は、ライト本体の表面を最小限に抑え、大幅な軽量化と省スペースを実現しています。LED光源による下方向への直接照明のほか、メタクリレート樹脂層によって光が拡散して空間に溶け込む間接照明を生み出します。

FLAT 04/05/06

Design VillaTosca

Collezione di sottili sospensioni a 4, 5 o 6 punti luce disposti linearmente. La struttura, realizzata da due lamine di alluminio anodizzato naturale frapposti da uno strato di metacrilato trasparente, fornisce luce indiretta verso l'alto e luce diretta verso il basso diffusa attraverso diffusori lenticolari in policarbonato. Alimentatore dimmerabile alloggiato nel rosone. Cavi di alimentazione e sospensione trasparenti.

Collection of thin suspensions with 4, 5, or 6 LED linear light sources. The structure is composed of three thin sheets, externally natural anodized aluminum and internally methacrylate, which provides direct light downward through lenticular polycarbonate diffusers, while the methacrylate layer spreads diffusely light in the surrounding. Dimmable power supply located in the ceiling rose. Transparent power and suspension cables.

直線上に並んだ4, 5, 6灯を備えた薄型のペンダントランプシリーズ。この構造体はアルマイト処理された二枚のアルミによって透明メタクリレートを挟む構造になっています。ポリカーボネート製レンズディフューザーによって上向きに間接照明、下向きに直接照明を拡散することができます。フランジカバー内には調光機能内蔵ドライバーが設置されています。電源ケーブルを兼ねた吊り下げワイヤーには細く柔軟性の高い素材を使用しました。

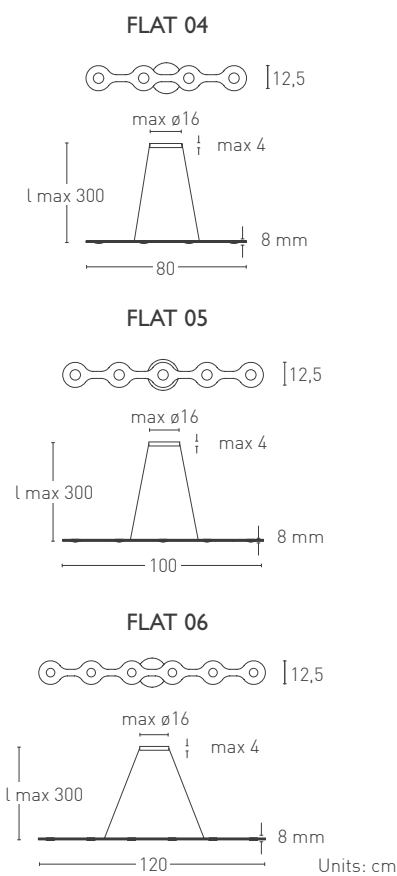

Finishes

- 172 Natural anodized aluminum
- 105 FT White
- 130 Gold foil
- 131 Silver foil
- 132 Copper foil

Diffuser

Lenticular PC

Cable

Transparent

Electronic driver

220/240V Dimmable only TRIAC
100/120V Dimmable only PUSH / 1-10V

Light source

LED

FLAT 04: LED 25W

2250lm 2700K CRI>90
2500lm 3000K CRI>90

FLAT 05: LED 32W

2850lm 2700K CRI>90
3150lm 3000K CRI>90

FLAT 06: LED 38W

3420lm 2700K CRI>90
3800lm 3000K CRI>90

A

Certification

CE EAC PS E F Classe I IP20



FLAT RING 3/6/12

Design VillaTosca

Collezione di sottili sospensioni a 3, 6 o 12 punti luce a LED disposti in circolo. La struttura, realizzata da due lamine di alluminio anodizzato naturale frapposti da uno strato di metacrilato trasparente, fornisce luce indiretta verso l'alto e luce diretta verso il basso attraverso diffusori lenticolari in policarbonato. Alimentatore dimmerabile alloggiato nel rosone. Cavi di alimentazione e sospensione trasparenti.

Collection of thin circular suspensions with 3, 6, or 12 LED light sources. The structure is composed of three thin sheets, externally natural anodized aluminum and internally methacrylate, which provides direct light downward through lenticular polycarbonate diffusers, while the methacrylate layer spreads diffusely light in the surrounding. Dimmable power supply housed in the ceiling rose. Transparent power and suspension cables.

リング状に3、6、12灯を備えた薄型のペンダントランプシリーズ。この構造体はアルマイト処理された二枚のアルミによって透明メタクリレートを挟む構造になっています。ポリカーボネート製レンズディフューザーによって上向きに間接照明、下向きに直接照明を拡散することができます。フランジカバー内には調光機能内蔵ドライバーが設置されています。電源ケーブルを兼ねた吊り下げワイヤーには細く柔軟性の高い素材を使用しました。

FLAT RING 3

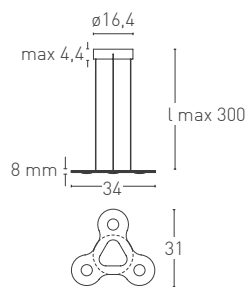

FLAT RING 6

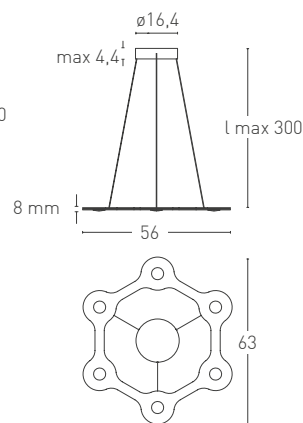

FLAT RING 12

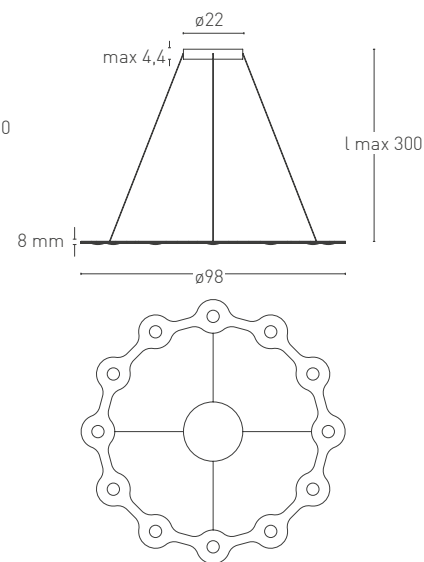

Units: cm



Finishes

- 172 Natural anodized aluminum
- 105 FT White
- 130 Gold foil
- 131 Silver foil
- 132 Copper foil

Diffuser

Lenticular PC

Cable

Transparent

Electronic driver

220/240V Dimmable only TRIAC
100/120V Dimmable only PUSH / 1-10V

Light source

LED

FLAT RING 3: LED 19W
1700lm 2700K CRI>90
1890lm 3000K CRI>90

FLAT RING 6: LED 38W
3420lm 2700K CRI>90
3800lm 3000K CRI>90

FLAT RING 12: LED 76W
6800lm 2700K CRI>90
7560lm 3000K CRI>90

A

Certification

CE EAC PS E F Classe I IP20



FLAT SATURN 1/2/3

Design VillaTosca

FLAT SATURN è un sistema di illuminazione che combina i modelli RING3, RING6, RING12 in un'unica sospensione. La lampada è disponibile nelle versioni a due elementi R3+R6, R6+R12 e nel modello a tre costruito combinando R3+R6+R12.

Alimentatore dimmerabile alloggiato nel rosone. Cavi di alimentazione e sospensione trasparenti.

FLAT SATURN is a lighting system which combines RING3, RING6, RING12 in one suspension. It's available in two rings versions: R3+R6 and R6+R12; and also in three rings version combining R3+R6+R12. Dimmable power supply located in the ceiling rose.

Transparent power and suspension cables.

「フラット・サトゥーン」は「フラット・リング3」、「フラット・リング6」、「フラット・リング12」を一つのペンダントランプとして組み合わせたシステムです。二つのエレメントを組み合わせたタイプ「R3+R6」、「R6+R12」と三つのエレメント全てを組み合わせた「R3+R6+R12」の三種類を用意しました。フランジカバー内には調光機能内蔵ドライバーが設置されています。電源ケーブルを兼ねた吊り下げワイヤーには細く柔軟性の高い素材を使用しました。

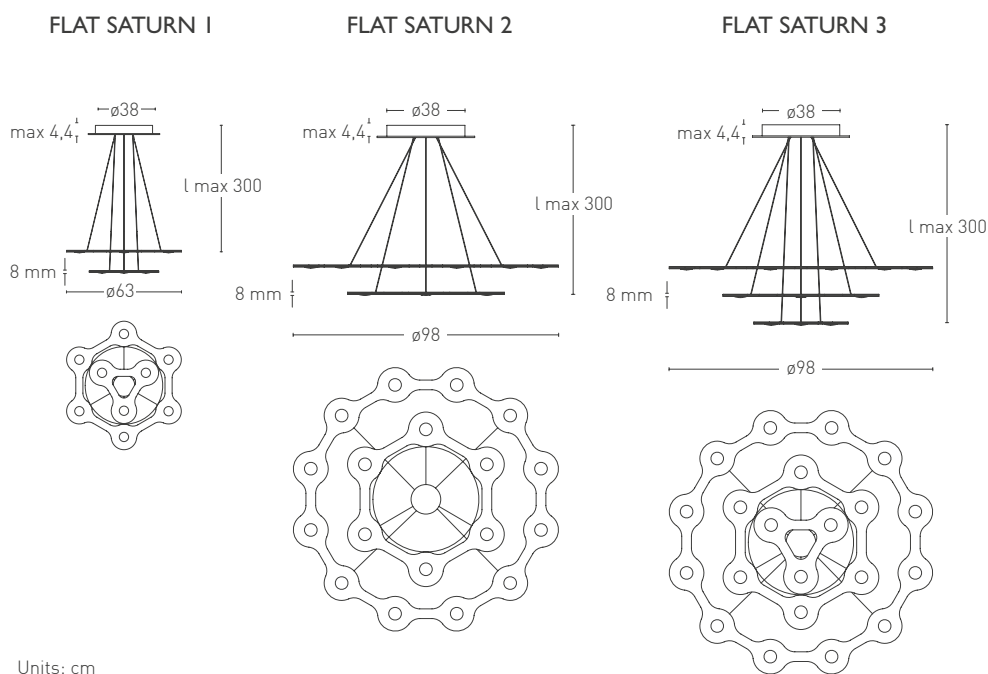

Units: cm



Finishes

- 172 Natural anodized aluminum
- 105 FT White
- 130 Gold foil
- 131 Silver foil
- 132 Copper foil

Diffuser

Lenticular PC

Cable

Transparent

Electronic Driver

220/240V Dimmable only TRIAC
100/120V Dimmable only PUSH / 1-10V

Light source

LED

FLAT SATURN 1: LED 57W
5100lm 2700K CRI>90
5670lm 3000K CRI>90

FLAT SATURN 2: LED 113W
10170lm 2700K CRI>90
11300lm 3000K CRI>90

FLAT SATURN 3: LED 132W
11900lm 2700K CRI>90
13323lm 3000K CRI>90

A

Certification

CE EAC PS E F Classe I IP20



SIBYLLA BT

Design Amedeo G. Cavalchini



RAGGIO DI LUCE

Un raggio di luce rubato al Sole. SIBYLLA BT modula la temperatura colore della luce. Oltre ai toni caldi e freddi è possibile variare anche l'intensità luminosa. Le sospensioni sono dotate di un sistema saliscendi per variare la loro distanza dai soffitti e dalle superfici che illuminano.

RAY OF LIGHT

A ray of light stolen from the Sun. SIBYLLA BT offers the possibility to vary the colour temperature of light and its intensity (warm and cold tones). The suspensions are equipped with a system to vary their distance from the ceilings and surfaces that illuminate.

光の線

「朝から夕の光を再現」『シビッラBT』は光の色温度を変えることができます。色温度の低い暖かな光から色温度の高い清んだ光への変化に加え、光の強さも変化させることができます。このペンダントランプの中には、天井からの高さが簡単に調整できる機構が内蔵されています。

SIBYLLA BT S/M/L

Design Amedeo G. Cavalchini

SIBYLLA BT S

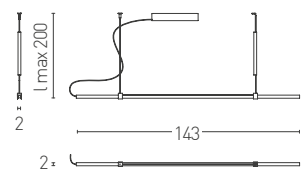

SIBYLLA BT M

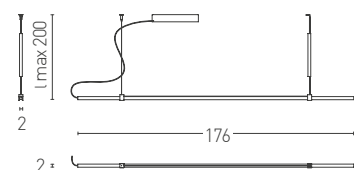

SIBYLLA BT L

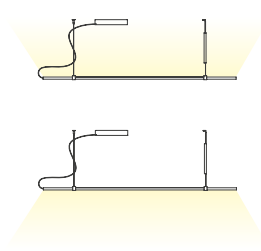
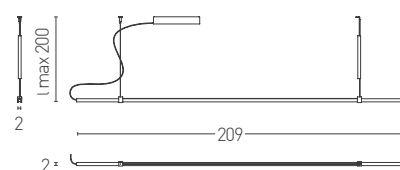

Con la sua forma allungata, una semplice barra in alluminio regolabile in altezza, SIBYLLA BT esprime la punta avanzata nella ricerca del light design. La sofisticata tecnologia dei LED a luce dinamica permette di controllare non solo l'intensità, ma anche la temperatura colore della luce. Tramite LCI Light App si può passare liberamente da 2700 gradi Kelvin, che corrispondono alla luce del sole poco prima del tramonto, a 6300 gradi Kelvin, con un effetto sole in pieno giorno.

A tre diverse lunghezze 143 cm, 176 cm e 209 cm, SIBYLLA BT crea scenografie luminose sempre nuove anche grazie al sistema saliscendi che ne varia la distanza dal soffitto e dalla superficie che illumina.

With its long shape, a simple height-adjustable aluminum bar, SIBYLLA BT is master level in light design research. The sophisticated technology of dynamic LED light allows the control of intensity but also the colour temperature of light. Via LCI Light App you can freely switch from 2700 Kelvin, which corresponds to sunlight just before sunset, to 6300 Kelvin, full daylight.

With three different lengths 143 cm, 176 cm and 209 cm, SIBYLLA BT always creates new lights sceneries thanks to the latch system that lead to change the distance from the ceiling and from the lighted up surface.

『シビッラBT』は一見すると細長いシンプルなアルミ製の照明ですが、簡単に高さの調整が可能であるなど、最新のデザインを持つペンダントランプです。機能面だけでなく光源部も最新のLED技術が盛り込まれており、光の強さだけでなく光の色温度までも調節が可能です。LCIのAppにより夕焼け前の色温度2700Kから日中の色温度6300Kの色温度までを再現する事が出来ます。『シビッラBT』は3つの異なるサイズで構成されており、そのサイズは143 cm、176 cm、209 cmとなります。これらのペンダントランプの中には、天井からの高さが調整できる機構が内蔵されています。

SET-UP MODALITIES

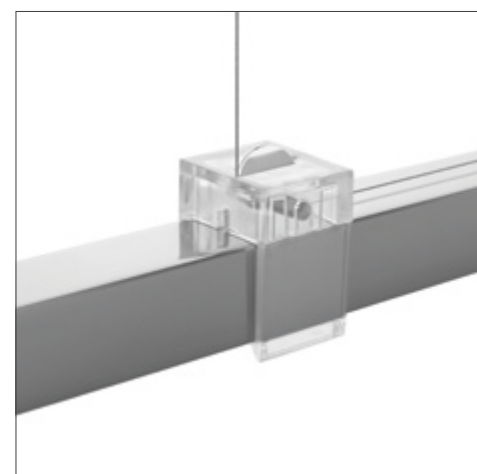
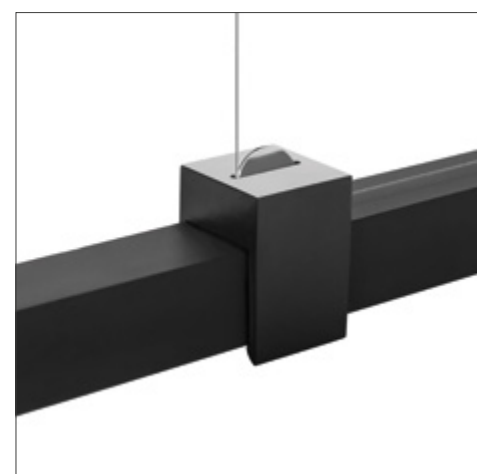
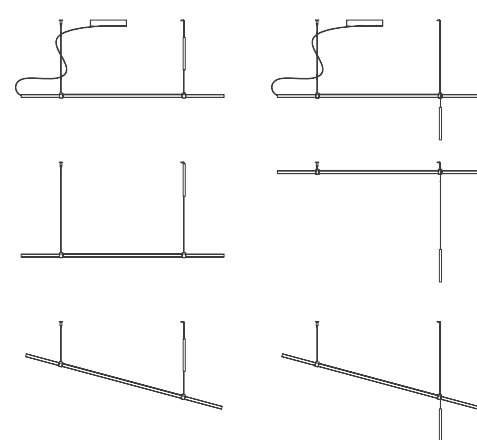

Finishes

- 172 Natural anodized aluminum
- 174 Black anodized aluminum

Diffuser

PMMA methacrylate

Clips

Black plastic or transparent plastic

Counterweight cylinder

● 150 Chrome

Ceiling rose

● 150 Chrome

Cable

Black with steel stop and steel wire

Electronic driver

Two-channel dimmer included
Control with (Bluetooth) application for Android and iOS Systems.

Light source

LED

LED 100/240V

Dinamic White Control DWC

DWC 2700/6300K CRI>90

SIBYLLA BT S 24W 2800lm

SIBYLLA BT M 30W 3500lm

SIBYLLA BT L 36W 4200lm

A

Certification

CE EAC PS E F IP20 Classe I



TAKÉ PLUS COLLECTION

Design Villa Tosca

ECOSISTEMI DI LUCE

TAKÉ PLUS è la linea di lampade, a sorgente luminosa LED, caratterizzata dalla grande flessibilità d'uso e personalità estetica. Grazie ad un progetto che ne ottimizza l'assemblaggio e processo produttivo, sono nate sette diverse tipologie di prodotto in grado di rispondere alle diverse esigenze di illuminazione sia di ambienti domestici che di grandi spazi retail o di intrattenimento, garantendo sempre un elevato standard di qualità della luce.

Le versioni da Terra (da 04 a 06 e OVAL) e S&P, vengono fornite con i nuovi driver a controllo della dimmerazione diretta tramite pulsante integrato nell'alimentatore o tramite App per sistemi operativi iOS e Android. Le versioni a Sospensione sono previste con accensione ON-OFF, a richiesta dimmer integrato nell'alimentatore con controllo della funzione PUSH o tramite App per sistemi operativi iOS e Android.

LIGHT ECOSYSTEM

TAKÉ PLUS is the lamp collection equipped with LED light sources, characterized by a great versatility and personality. Thanks to a process that optimizes assembly and productive process, this collection has built up seven different types of products to meet the diverse needs of lighting: from the most intimate spaces of home, to major retail and entertainment spaces, always ensuring a high standard of quality of light.

In standard equipment for ground versions (from 04 to 06 and OVAL) and S&P, new drivers with direct control of dimming via dimmer or via App for iOS and Android operating systems.

The suspension version are provided with ON-OFF switch, by request integrated dimmer in the power supply with control of PUSH function or via App for iOS and Android operating systems.

ライティング・エコシステム

「タケ・プラス」は様々な使い方ができるLED光源を内蔵した個性的なデザインが特徴のランプシリーズです。

組み立て及び製造工程を最適化したデザインから7種類のタイプが生まれました。これによって「高い水準の光のクオリティー」を保持しながら家庭的な環境から商空間に至るまで幅広いニーズにこたえることができます。

フロアタイプ (04, 05, 06、オーバル)、S & Pタイプには新たに照明本体から調光する機能に加え、スマートフォン (iOSおよび Android) 等からAppを通じて調光可能な機能も搭載しました。ペンダントタイプの「オン/オフ」シリーズもオプションで同機能をお選びいただけます。

TAKÉ PLUS TOUCH 01/02/03

Design VillaTosca

TAKÉ PLUS Touch 01 è la versione da tavolo della serie: costituita da un solo elemento illuminante. TAKÉ PLUS Touch 02 e 03 rappresentano le versioni da "conversazione" rispettivamente a 2 e 3 elementi. Sono dotate di touch dimmer per l'accensione e variazione dell'intensità luminosa. Il diffusore, è realizzato in Polietilene (PE) bianco opale. Le finiture disponibili per le basi sono: cromato e bianco opaco.

TAKÉ PLUS Touch 01 table version made of one lighting module. TAKÉ PLUS Touch 02 and 03 are the "conversation" versions made of 2 and 3 sections. They are equipped with touch dimmer for starting and luminous intensity variation. The diffuser is made of opal white Polyethylene (PE). Bases available in the following finishes: chrome and matte white.

「タケ・プラス タッチ01」は「タケ」シリーズのテーブルランプです。「タケ・プラス タッチ02」と「タッチ03」は2つ及び3つのモジュールから構成される、会話のしやすい落ち着いた雰囲気演出に向けたフロアタイプのランプです。ランプの上部には電源ボタンがあり、同じ部分を操作することで調光が可能です。グローブはポリエチレン(PE)製(色/オパール・ホワイト)。筐体の仕上げはクロムとホワイト半光沢。

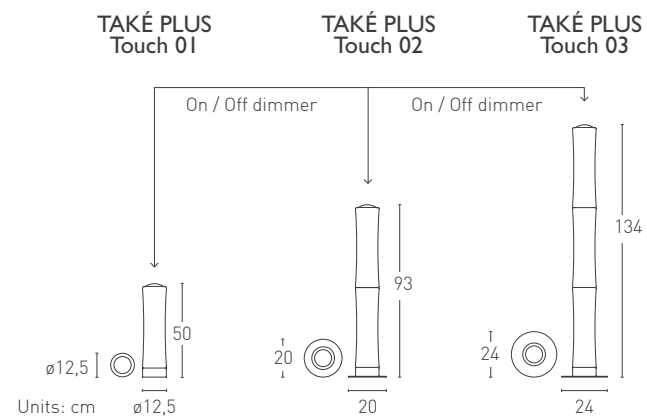

Finishes

- 106 Matte white
- 150 Chrome

Diffuser

PE Polyethylene opal white

Cable

Transparent

Electronic driver

Dimmable included

Light source

LED

LED 100/240V

TAKÉ PLUS Touch 01 16W
1100lm 3000K CRI>90

TAKÉ PLUS Touch 02 32W
2200lm 3000K CRI>90

TAKÉ PLUS Touch 03 48W
3300lm 3000K CRI>90

A

Certification

CE EAC PS E F Classe I IP20



TAKÉ PLUS BT 04/05/06

Design VillaTosca

Lampade da terra, disponibili in tre differenti altezze a seconda degli elementi utilizzati (4, 5 o 6). Dotata di regolatore di intensità luminosa, la lampada diffonde una luce intensa e uniforme lungo tutto il diffusore realizzato in PE bianco opale. Ogni elemento utilizza una sorgente luminosa LED da 16W a temperatura colore prossimale di 3000K.

In dotazione standard nuovi driver con controllo della dimmerazione diretta tramite dimmer a pedale o tramite App per sistemi operativi iOS e Android.

La base e il dimmer a pedale sono di metallo e disponibili in finitura bianco opaco o cromato.

Floor lamp in three different heights according to the used sections (4, 5 or 6). The lamp - equipped with a lighting dimmer - diffuses an intense and uniform light along the whole diffuser made of opal white PE. Each module has a 16W LED lighting source with 3000K colour temperature.

In standard equipment new drivers with direct control of dimming via pedal dimmer or via App for iOS and Android operating systems.

The base and the pedal dimmer are made of metal and available in matte white or chrome finish.

このフロアタイプのバージョンでは、モジュールの使用数（4、5、6）によって3つの高さのバリエーションがあります（調光器付き）。ランプは、オパール・ホワイト仕上げのポリエチレン製のグローブ全体を通して全体的にくっきりとした光を広げます。各モジュールは、16ワットのLED光源を内蔵しており、色温度は3000ケルビン。調光機能については、従来の照明本体から直接操作するものに加え、新たにスマートフォン（i-OSおよび Android）等からAppを通じて調光可能な機能も搭載しました。照明ベースと調光装置ともなるアダプターは金属製で塗装は、ホワイト半光沢、クロムの二種類があります。

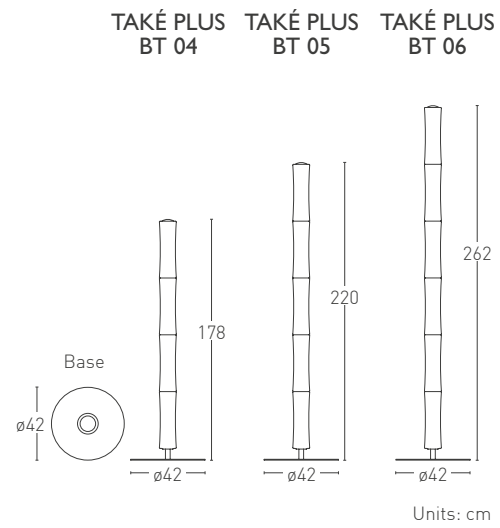

Finishes

- 106 Matte white
- 150 Chrome

Diffuser

PE polyethylene opal white

Cable

Transparent

Electronic driver

Dimmable included

Dimmer

Pedal dimmer and Bluetooth control App for Android and iOS systems

Light source

LED

LED 100/240V

TAKÉ PLUS BT 04 64W
4400lm 3000K CRI>90

TAKÉ PLUS BT 05 80W
5500lm 3000K CRI>90

TAKÉ PLUS BT 06 96W
6600lm 3000K CRI>90

A

Certification

CE EAC PS E F Classe I IP20



TAKÉ PLUS BT OVAL 05/06

Design VillaTosca

TAKÉ PLUS BT OVAL, lampada da terra con stelo inclinato di 12° su base ovale composta da 5 o 6 elementi. La sorgente LED utilizzata ha temperatura colore di 3000K e diffonde uniformemente la luce lungo tutto l'elemento diffusore in PE. Le potenze variano da 80W per il modello a 5 moduli a 96W per il modello a 6 moduli.

In dotazione standard nuovi driver con controllo della dimmerazione diretta tramite dimmer a pedale o tramite App per sistemi operativi iOS e Android.

La base e il dimmer a pedale sono di metallo e disponibili in finitura bianco opaco o cromato.

TAKÉ PLUS BT OVAL, floor lamp with a 12° inclined stem, on an oval base, made of 5 or 6 sections. The LED light source has a 3000K colour temperature and diffuses uniformly the light along the whole PE diffuser. The lighting powers vary from 80W for the 5 sections model to 96W for the 6 sections model.

In standard equipment new drivers with direct control of dimming via pedal dimmer or via App for iOS and Android operating systems.

The base and the pedal dimmer are made of metal and available in matte white or chrome finish.

「タケ・プラス BTオーバル」は、楕円形のベースに垂直から12度傾斜した支柱に5つあるいは6つのモジュールで構成されたフロアタイプのランプ、LED光源をポリエチレン製グローブ内に中心から全体に向け配置、それにより各モジュールは色温度3000ケルビンの光を周囲に均等に広げることができます。出力は5モジュールで80ワット、6モジュールで96ワットの二種類があります。調光機能については、従来の照明本体から直接操作するものに加え、新たにスマートフォン (i-OSおよび Android) 等からAppを通じて調光可能な機能も搭載しました。照明ベースと調光装置ともなるアダプターは金属製で塗装は、ホワイต์半光沢、クロムの二種類があります。



Finishes

- 106 Matte white
- 150 Chrome

Diffuser

PE Polyethylene opal white

Cable

Transparent

Electronic driver

Dimmable included

Dimmer

Pedal dimmer and Bluetooth control App for Android and iOS systems

Light source LED

LED 100/240V

TAKÉ PLUS BT OVAL 05 80W
5500lm 3000K CRI>90

TAKÉ PLUS BT OVAL 06 96W
6600lm 3000K CRI>90

A

Certification

CE EAC PS E F Classe I IP20

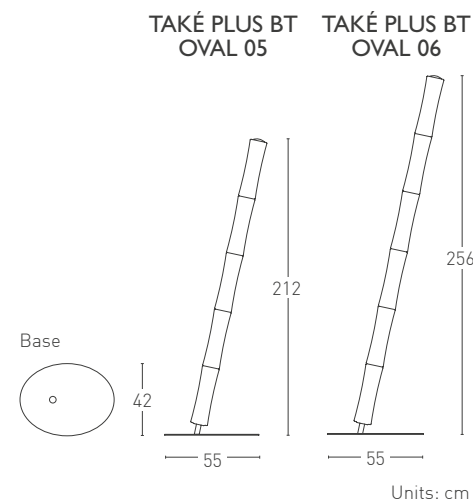

TAKÉ PLUS BT S&P 04/05/06

Design VillaTosca

TAKÉ PLUS BT S&P è una particolare versione soffitto-pavimento che ottimizza lo spazio necessario al collocamento della lampada. Il punto di ancoraggio è a soffitto e viene alimentata tramite una normale presa elettrica a parete. È disponibile a 4, 5 o 6 moduli. È dotata di variatore di intensità luminosa e fornisce una luce uniforme lungo tutto l'elemento diffusore grazie alla particolare tecnologia LED utilizzata.

In dotazione standard nuovi driver con controllo della dimmerazione diretta tramite dimmer a pedale o tramite App per sistemi operativi iOS e Android.

Dimmer a pedale e parti metalliche sono disponibili in bianco opaco o cromato.

TAKÉ PLUS BT S&P is a unique ceiling-floor version that optimizes the available space to collocate the lamp. The anchoring point is on the ceiling and it is powered through a normal electric wall socket. It is available with 4, 5 or 6 sections. It is equipped with a dimmer and gives a uniform light along the whole diffuser thanks to its particular LED technology.

In standard equipment new drivers with direct control of dimming via pedal dimmer or via App for iOS and Android operating systems.

Pedal dimmer and metal parts are available in matte white or chrome.

「タケ・プラス BT S&P」は、特別なシーリング/フロアーランプのバージョンです。空間のニーズに適応した形でランプを配置することができます。アンカーポイントは、天井に取り付け、電源は通常の壁に取り付けられた電源プラグを利用することができます。4、5、6モジュールのバリエーションがあります。なお調光器を内蔵しており、特別なLEDテクノロジー採用により光を各モジュール全体に広げることが出来ます。調光機能については、従来の照明本体から直接操作するものに加え、新たにスマートフォン（i-OSおよびAndroid）等からAppを通じて調光可能な機能も搭載しました。照明ベースと調光装置ともなるアダプターは金属製で塗装は、ホワイト半光沢、クロムの二種類があります。

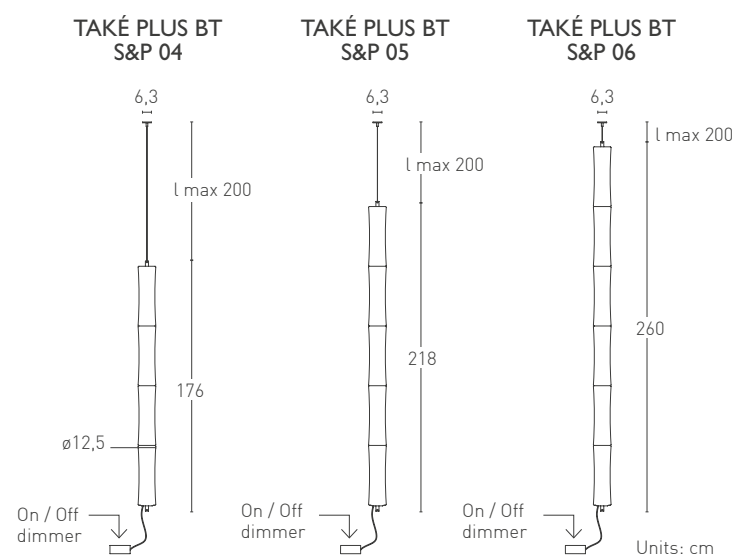

Finishes

- 106 Matte white
- 150 Chrome

Diffuser

PE Polyethylene opal white

Cable

Transparent

Electronic driver

Dimmable included

Dimmer

Pedal dimmer and Bluetooth control App for Android and iOS systems

Light source

LED

LED 100/240V

TAKÉ PLUS BT S&P 04 64W
4400lm 3000K CRI>90

TAKÉ PLUS BT S&P 05 80W
5500lm 3000K CRI>90

TAKÉ PLUS BT S&P 06 96W
6600lm 3000K CRI>90

A

Certification

CE EAC PS E F Classe I IP20



TAKÉ PLUS BT ON-OFF S1/S2/S3

Design VillaTosca

TAKÉ PLUS BT ON/OFF si declina nelle versioni a sospensione da 1 fino a 3 elementi. Gli attacchi forniti consentono di realizzare versioni in orizzontale, verticale o obliquo. A seconda del numero di elementi, varia la potenza luminosa dei circuiti LED utilizzati. La temperatura di colore dei LED utilizzati è 3000K. Il diffusore è realizzato in PE bianco opale. La finitura delle parti metalliche è bianco opaco o cromato. Accensione ON-OFF, a richiesta dimmer integrato nell'alimentatore con controllo della funzione PUSH o tramite LCI Light App per sistemi operativi iOS e Android.

TAKÉ PLUS BT ON/OFF extends its versions from 1 up to 3 sections suspension lamps. The supplied ceiling holders allow you to make a horizontal, vertical or oblique lamp mounting. According to the number of elements, the light power of the LED strips varies. The colour temperature of the LED is 3000K. The diffuser is made in opal white PE. The metal parts finish is matte white or chrome. ON-OFF switch and upon request integrated dimmer in the power supply with control of PUSH function or via LCI Light App for iOS and Android operating systems.

「タケ・プラスBT-オン/オフ」は、1つから3つのモジュールで展開されるペンダントタイプのランプです。付属の取付金具によって、水平/垂直/傾斜の異なる設置が可能です。全体の出力はモジュールに内蔵されるLED光源の違いで変動します。色温度は3000ケルビンのLEDを使用。グローブはポリエチレン製のオパール・ホワイト仕上げ。金属部の塗装は、ホワイト半光沢、クロムの二種類があります。調光機能については長押しボタン式の調光に加え、新たにスマートフォン (i-OSおよびAndroid) 等からAppを通じて調光可能な機能を選択することもできます。



TAKÉ PLUS S1

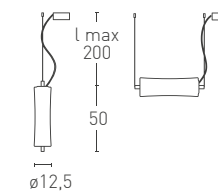

TAKÉ PLUS S2

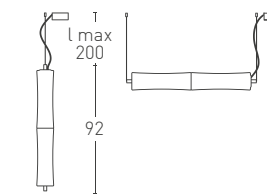

TAKÉ PLUS S3

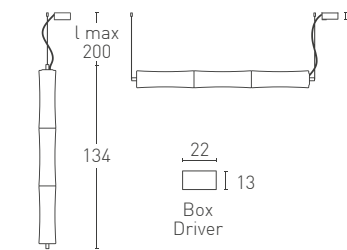

Units: cm

SET-UP MODALITIES

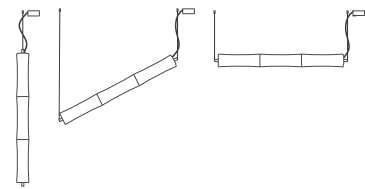

Finishes

- 106 Matte white
- 150 Chrome

Diffuser

PE Polyethylene opal white

Cable

Transparent

Electronic driver

Standard version ON / OFF or Dimmer included by request for BT version (Bluetooth) application for Android and iOS Systems

Light source

LED

LED 100/240V

TAKÉ PLUS ON/OFF S1 16W

1100lm 3000K CRI>90

TAKÉ PLUS ON/OFF S2 32W

2200lm 3000K CRI>90

TAKÉ PLUS ON/OFF S3 48W

3300lm 3000K CRI>90



Certification

CE ENEC PS E F Classe I IP20

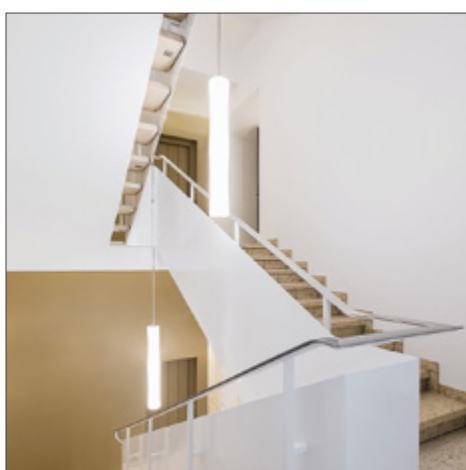

TAKÉ PLUS BT ON-OFF S4/S5/S6

Design VillaTosca

TAKÉ PLUS BT ON/OFF si declina nelle versioni a sospensione da 4 fino a 6 elementi. Gli attacchi forniti consentono di realizzare versioni in orizzontale, verticale o obliquo. A seconda del numero di elementi, varia la potenza luminosa dei circuiti LED utilizzati. La temperatura di colore dei LED utilizzati è 3000K. Il diffusore è realizzato in PE bianco opale. La finitura delle parti metalliche è bianco opaco o cromato. Accensione ON-OFF, a richiesta dimmer integrato nell'alimentatore con controllo della funzione PUSH o tramite LCI Light App per sistemi operativi iOS e Android.

TAKÉ PLUS BT ON/OFF extends its versions from 4 up to 6 sections suspension lamps. The supplied ceiling holders allow you to make a horizontal, vertical or oblique lamp mounting. According to the number of elements, the light power of the LED strips varies. The colour temperature of the LED is 3000K. The diffuser is made in opal white PE. The metal parts finish is matte white or chrome. ON-OFF switch and upon request integrated dimmer in the power supply with control of PUSH function or via LCI Light App for iOS and Android operating systems.

「タケ・プラスBT-オン/オフ」は、4から6のモジュールで展開されるペンダントタイプのランプです。付属の取付金具によって、水平/垂直/傾斜の異なる設置が可能です。全体の出力はモジュールに内蔵されるLED光源の違いで変動します。色温度は3000ケルビンのLEDを使用。グローブはポリエチレン製のオパール・ホワイト仕上げ。金属部の塗装は、ホワイト半光沢、クロムの二種類があります。調光機能については長押しボタン式の調光に加え、新たにスマートフォン (iOSおよびAndroid) 等からAppを通じて調光可能な機能を選択することもできます。

TAKÉ PLUS S4

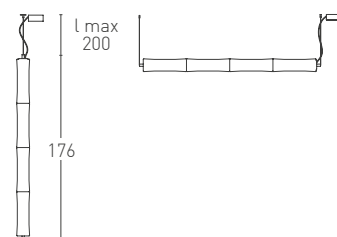

TAKÉ PLUS S5

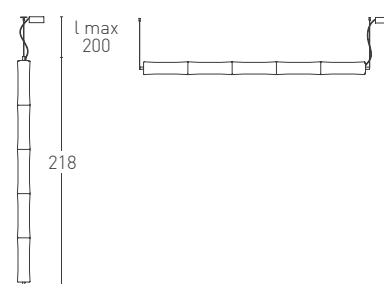

TAKÉ PLUS S6

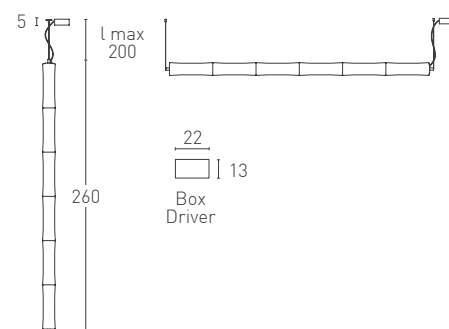

Finishes

- 106 Matte white
- 150 Chrome

Diffuser

PE Polyethylene opal white

Cable

Transparent

Electronic driver

Standard version ON / OFF or Dimmer included by request for BT version (Bluetooth) application for Android and iOS Systems

Light source **LED**

LED 100/240V

TAKÉ PLUS ON/OFF S4 64W

4400lm 3000K CRI>90

TAKÉ PLUS ON/OFF S5 80W

5500lm 3000K CRI>90

TAKÉ PLUS ON/OFF S6 96W

6600lm 3000K CRI>90

A

Certification

CE EAC PS E F Classe I IP20



TAKÉ 27/27-I / BUBBLE 04/08

Design VillaTosca

TAKÉ 27 è un sistema di lampade a sospensione semplificato, che permette di utilizzare normali lampadine con attacco E27 fino ad un massimo di 57W. La versione da 1 modulo può essere fissata al soffitto tramite rosone oppure con attacco ad incasso (TAKÉ 27-I). Disponibile con dettagli metallici cromati o laccati bianco opaco.

Partendo dal singolo modulo TAKÉ 27 è possibile configurare sospensioni multiple utilizzando 4, 8 o 12 elementi. Ogni versione dispone di un rosone *ad hoc* con finitura cromo o bianco opaco.

TAKÉ 27 is a simplified system of suspension lamps which allows to use conventional bulbs with E27 sockets, max 57W. The 1 section version can be mounted to the ceiling by means of the ceiling rose or the built-in kit (TAKÉ 27-I). Available with chrome or matte white metal details.

Starting from the single section of TAKÉ 27 it is possible to create multiple suspensions made of 4, 8 or 12 sections. Each version is supplied with an ad hoc ceiling rose, available in chrome or matte white.

「タケ27」は、シンプルなペンダントタイプのランプシステム。E27の金口に最大57ワットの電球の使用が可能です。このシングルモジュールのバージョンは、フランジの取付金具または埋め込み式 (タケ27-I)の2種類があります。ディテール部品の塗装は、クロム、ホワイト半光沢があります。

「タケ27」のシングルモジュールをベースに4、8、12灯式のシャンデリアタイプの構成が可能です。各バージョンごとに特別なフランジが用意されています。塗装は、クロムとホワイト半光沢があります。



Finishes

- 106 Matte white
- 150 Chrome

Diffuser

PE Polyethylene opal white

Cable

Transparent

Suggested light source

- 220/240V E27
- 100/120V E26
- Halogen ECO max 57W
- ECO Fluo
- LED

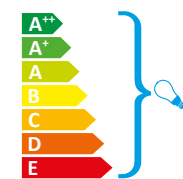

Certification

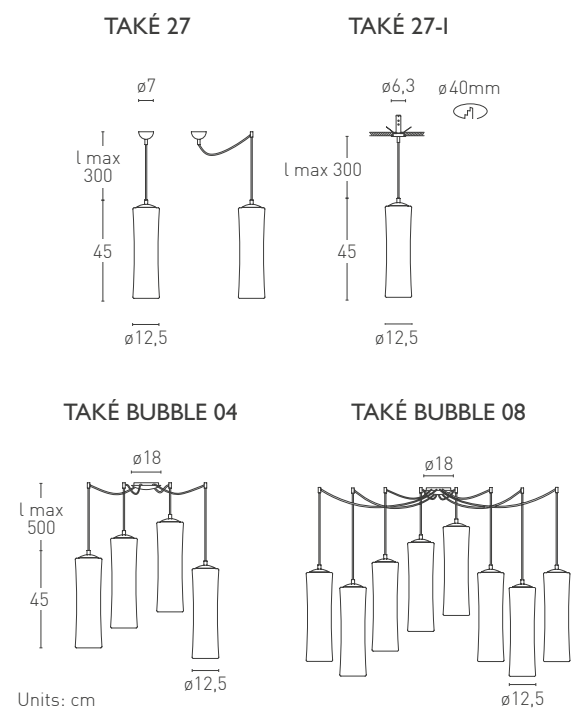

Units: cm



TAKÉ OPEN AIR

Design VillaTosca

OUTDOOR COLLECTION

Grazie agli accessori di cui è composta la serie, la lampada si presta ad essere utilizzata in vari contesti; con ancoraggio a terra o tramite picchetto diventa il prodotto ideale per costruire sistemi di illuminazione da giardino/terrazzo personalizzati.

OUTDOOR COLLECTION

Thanks to the various accessories available, this lamp is suitable for use in various contexts; by anchoring on the ground or through a picket, it becomes the ideal product to create customized garden/terrace lighting systems.

アウトドア・コレクション

設置する場所にあわせた様々なアクセサリーを用意しています。基本はランプを付属の固定台座で設置しますが、アクセサリーの「ピケット（地杭）」で直接地面に差し込む事もでき、庭やテラスの照明システムを構築するのに理想的なランプです。

TAKÉ OPEN AIR 03/10/11/21

Design VillaTosca

TAKÉ OPEN AIR è il sistema di illuminazione per esterni con sistema di ancoraggio al terreno personalizzabile. La lampada può essere appoggiata al terreno con l'accessorio base o tramite l'accessorio picchetto - PICKET.

È disponibile per parete e in tre diverse altezze.

TAKÉ OPEN AIR is an outdoor lighting system with possibility of customized ground anchoring. The lamp can be placed in the ground using the steel base or the picket. It is available for wall bracket and in three different heights.

「タケ・オープンエア」は屋外向け照明システムです。用途に応じた専用のアタッチメントによって様々な使い方が可能です。屋外の壁面用、地上用があり、地上用には支柱によって固定、もしくは「ピケット（地杭）」によって直接地面に差し込んで固定するタイプがあります。地上用は3段階の高さのバージョンを用意しました。

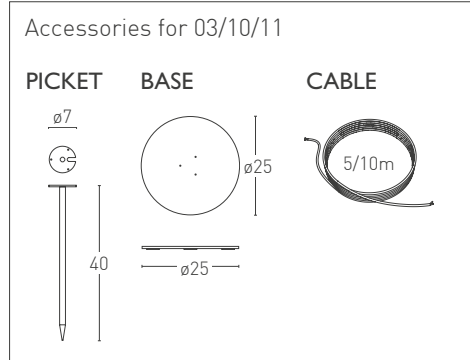
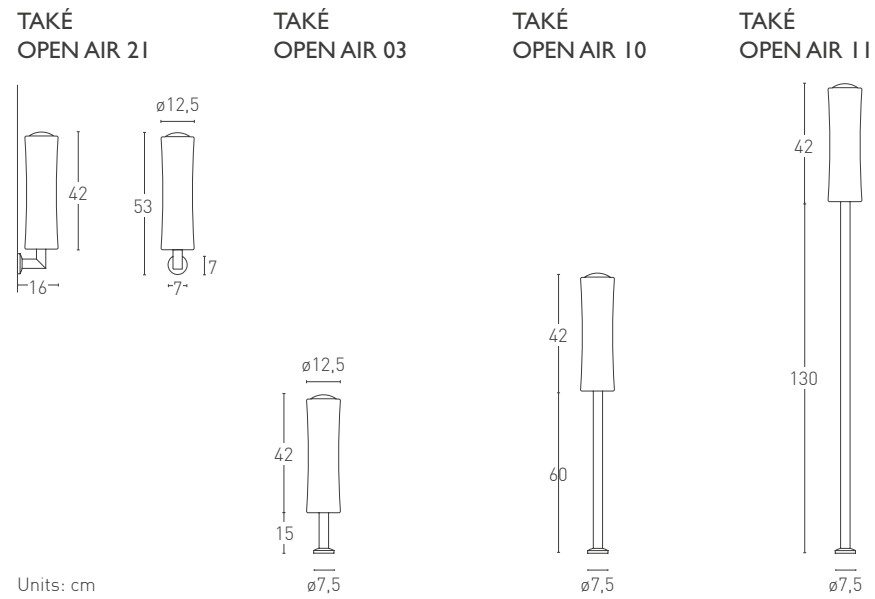

Finishes

- 173 Dark brown (outdoor use)

Diffuser

PE Polyethylene opal white

Cable

5/10 m on demand

Suggested light source

220/240V E27

100/120V E26

Halogen ECO max 57W

ECO Fluo

LED

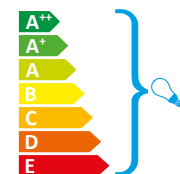

Certification

CE EAC PS E F Classe I IP54



ICEGLOBE COLLECTION

Design VillaTosca

LUCE ARTICA

ICEGLOBE è l'iconica collezione di lampade a sospensione, plafoniera, applique, terra e tavolo realizzate in polycarbonato microforato con la tecnologia dello stampaggio rotazionale.

La collezione, che dal 2005 è uno tra i prodotti best seller, è declinata in innumerevoli versioni realizzate con sfere dal diametro differente: la famiglia ICEGLOBE include sfere con diametro di cm: 30, 45, 57, 78; la famiglia MINI sfere con diametro 20 cm e la famiglia MICRO sfere dal diametro 12 cm.

ARTIC LIGHT

ICEGLOBE is the iconic collection of suspension, ceiling, wall, floor and table lamps made of micropunched polycarbonate by rotational molding technology. The collection, that represents one of the "best sellers" products since 2005, is available in numerous versions made of spheres with different diameters: the ICEGLOBE family includes spheres with diameters of 30, 45, 57, 78 cm; the MINI family includes spheres with diameter of 20 cm while the MICRO family includes spheres with diameter of 12 cm.

北極からのひかり

「アイスグローブ」は、ペンダントタイプ、シーリングタイプ、ウォールタイプ、フロアタイプ、テーブルタイプで提供している、ヴィットラトスカを代表する照明コレクションです。耐熱性ポリカーボネートを回転成形して作った本体から無数の孔を通して光が射します。本コレクションは、2005年から続くベストセラー商品の一つとしてさまざまなタイプとサイズを展開。「アイスグローブ」シリーズには、直径30センチ、45センチ、57センチ、78センチがあります。「ミニ」シリーズは直径20センチ、「マイクロ」シリーズは直径12センチとなります。

ICEGLOBE 02/L02/MAXI 02/GIANT 02

Design VillaTosca

ICEGLOBE da tavolo e terra. Disponibile nei diametri da 30, 45, 57 e 78 cm.

La sfera realizzata in policarbonato microforato e autoestinguente é appoggiata nella base metallica con finitura nichel satinato. Regolatore di intensità luminosa incluso.

ICEGLOBE table and floor model with diameters of 30, 45, 57 and 78 cm.

The sphere, made of self-extinguishing micropunched polycarbonate, is supported on a metallic base characterized by a satin nickel finish. Dimmer included.

アイスグローブのテーブル/フロアタイプのランプ。ニッケルサテン仕上げのメタル製のベースに載せられるグローブの直径は30,45,57,78cmから選べます。素材はポリカーボネート製で自己消化性素材です。調光器付き。

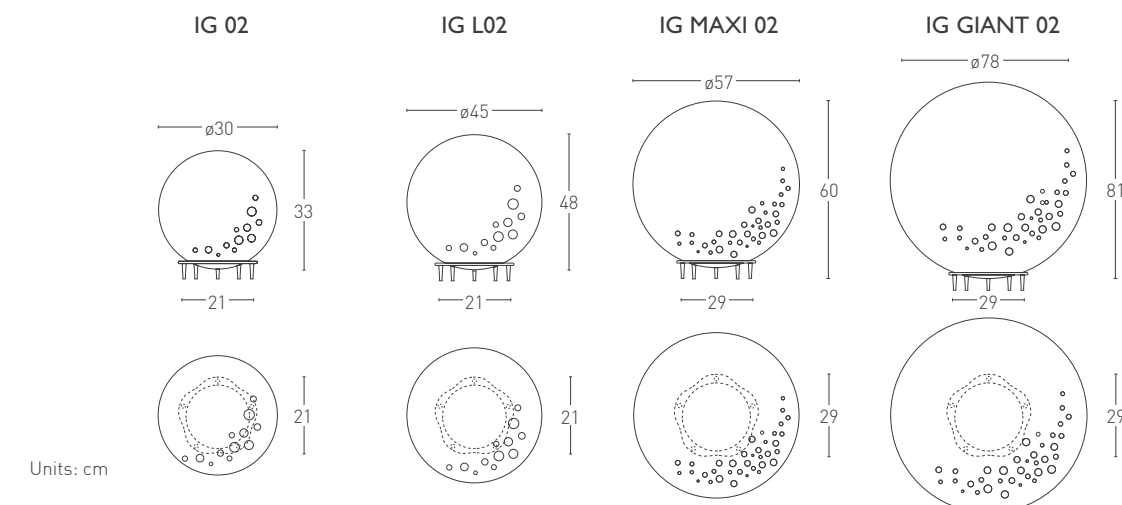

Finishes

- 166 Satin nickel

Diffuser

PC Polycarbonate

Cable

Transparent

Dimmer

Included

Suggested light source

220/240V E27

100/120V E26

Halogen ECO

ICEGLOBE 02 max 77W

ICEGLOBE L02 max 116W

ICEGLOBE MAXI 02 max 116W

Halogen ECO

ICEGLOBE GIANT 02 max 205W

LED dimmable min 5W

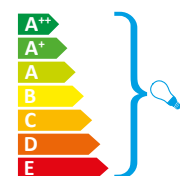

Certification



ICEGLOBE 10/11/12

Design VillaTosca

ICEGLOBE da terra con sfera da 30 cm. Stelo disponibile in 3 diverse altezze. Diffusore realizzato in policarbonato microforato autoestinguente. Stelo e base realizzati in metallo con finitura nichel satinato. Regolatore di intensità luminosa incluso.

ICEGLOBE floor model with a sphere of 30 cm. Stem available in 3 different heights. Diffuser made of self-extinguishing micropunched polycarbonate. Stem and base made of metal with a satin nickel finish. Dimmer included.

グローブ直径30cmのフロアタイプの「アイスグローブ」。支柱の長さの違いから、3つの高さが選べます。グローブは、ポリカーボネート(自己消化性素材)製。支柱とベースは、ニッケルサテン仕上げのメタル製。調光器付き。

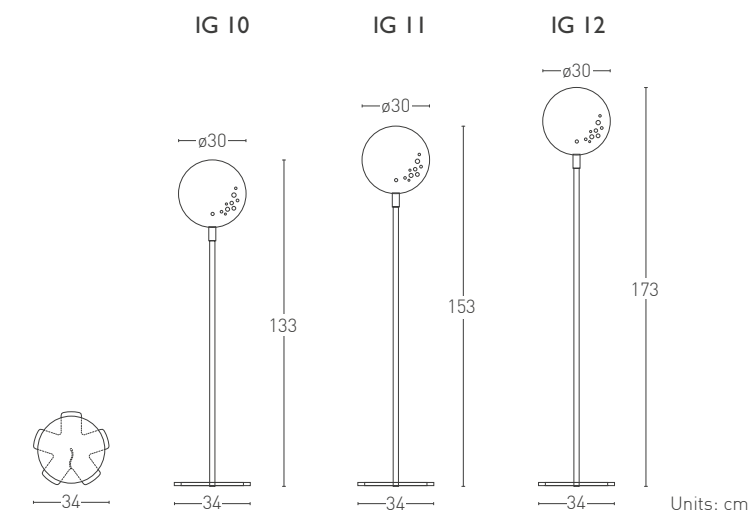

Finishes

● 166 Satin nickel

Diffuser

PC Polycarbonate

Cable

Transparent

Dimmer

Included

Suggested light source

220/240V E27

100/120V E26

Halogen ECO max 116W

LED dimmable min 5W

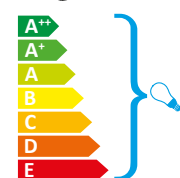

Certification

CE EAC



ICEGLOBE LI0/LI1

Design VillaTosca

ICEGLOBE da terra con sfera da 45 cm. Stelo disponibile in due diverse altezze. Diffusore realizzato in policarbonato microforato autoestinguento. Stelo e base realizzati in metallo con finitura nichel satinato. Regolatore di intensità luminosa incluso.

ICEGLOBE floor model with a sphere of 45 cm. Stem available in two different heights. Diffuser made of self-extinguishing micropunched polycarbonate. Stem and base made of metal with a satin nickel finish. Dimmer included.

フロアタイプの「アイスグローブ」。グローブは直径45cm。ステムの高さは2つの長さ中から選べます。グローブは、ポリカーボネート(自己消化性素材)製。ステムとベースは、ニッケルサテン仕上げのメタル製。調光器付き。



Finishes

● 166 Satin nickel

Diffuser

PC Polycarbonate

Cable

Transparent

Dimmer

Included

Suggested light source

220/240V E27

100/120V E26

Halogen ECO max 1x116W

LED dimmable min 5W

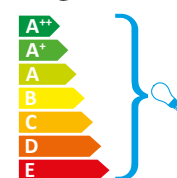

Certification

CE EAC PS E F IP20

IG LI0

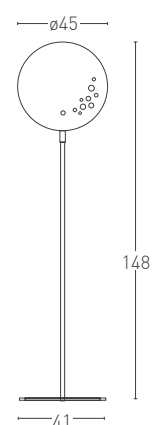

IG LI1

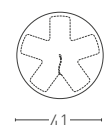
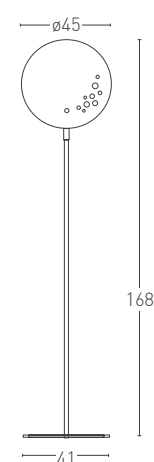

Units: cm



ICEGLOBE 21/21L

Design VillaTosca

ICEGLOBE nelle versioni da parete e plafone con diametro 30 o 45 cm. Diffusore realizzato in policarbonato microforato autoestinguente, attacco a muro con finitura nichel satinato.

ICEGLOBE in the wall and in the ceiling versions with a diameter of 30 cm and 45 cm. Diffuser made of self-extinguishing micropunched polycarbonate, wall holder with a satin nickel finish.

アイスグローブのウォール/シーリングタイプ。グローブの直径は30cmと45cm。グローブは、ポリカーボネート(自己消化性素材)製。取り付けベースは、ニッケルサテン仕上げのメタル製。

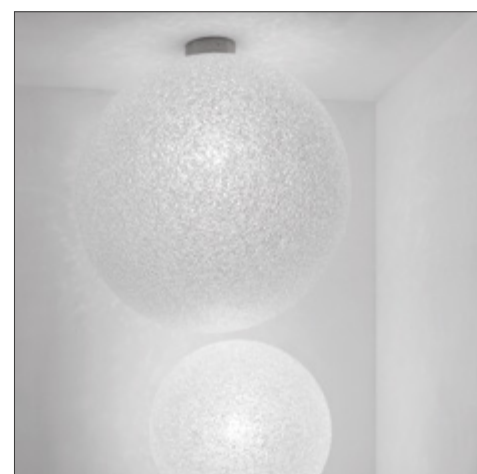

IG 21

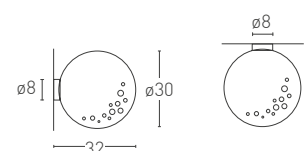

IG 21L

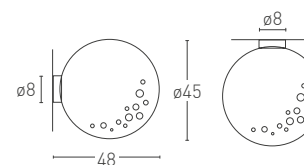

Units: cm



Finishes

- 166 Satin nickel

Diffuser

PC Polycarbonate

Cable

Transparent

Suggested light source

220/240V E27

100/120V E26

 Halogen ECO

ICEGLOBE 21 max 77W

ICEGLOBE 21L max 116W

 ECO Fluo

 LED

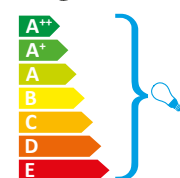

Certification

    Classe I IP20



ICEGLOBE S/LS/MAXI S/GIANT S

Design VillaTosca

ICEGLOBE nelle versioni a sospensione da 30, 45, 57 e 78 cm. Diffusore realizzato in policarbonato microforato autoestinguente, rosone con finitura nichel satinato. Possibilità di attacco a soffitto decentrato rispetto al rosone per i modelli: IG S, IG LS, IG MAXI S.

ICEGLOBE line for suspension lamps of 30, 45, 57 and 78 cm. Diffuser made of self-extinguishing micropunched polycarbonate, ceiling rose with a satin nickel finish. It may be mounted on the ceiling off centre with respect to the ceiling rose for the models: IG S, IG LS, IG MAXI S.

ペンダントタイプのアイスグローブ・シリーズは直径30、45、57、78 cmの四つのサイズで展開。グローブは、自己消化性を持つポリカーボネート製。フランジは、ニッケル・サテン仕上げ。「IG S」、「IG LS」、「IG MAXI S」は、ランプをフランジとは別の位置に設置することも可能です。

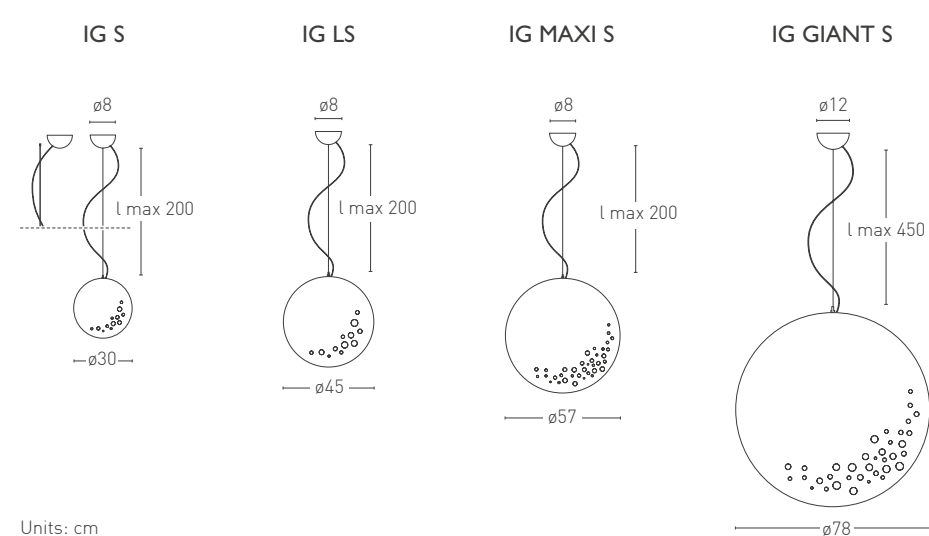

Units: cm



Finishes

● 166 Satin nickel

Diffuser

PC Polycarbonate

Cable

Transparent

Suggested light source

220/240V E27

100/120V E26

Halogen ECO

ICEGLOBE S max 1x77W

ICEGLOBE LS / MAXI S max 1x116W

ICEGLOBE GIANT S max 1x205W

ECO Fluo

LED

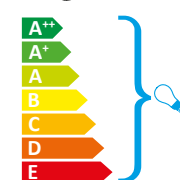

Certification

CE EAC Classe I IP20



ICEGLOBE SEMI MAXI / SEMI GIANT

Design VillaTosca

ICEGLOBE nelle versioni a semisfera a sospensione da 57 o 78 cm di diametro. Diffusore realizzato in policarbonato microforato autoestinguente, rosone con finitura nichel satinato. Possibilità di attacco a soffitto decentrato rispetto al rosone per il modello IG SEMI MAXI.

ICEGLOBE in the half-sphere suspension models with a diameter of 57 or 78 cm. Diffuser made of self-extinguishing micropunched polycarbonate, supplied with ceiling rose with a satin nickel finish. It may be mounted on the ceiling off centre with respect to the ceiling rose for IG SEMI MAXI only.

アイスグローブの半球体セードのバージョン。直径57と78cmのサイズで構成されています。グローブは、自己消化性を持つポリカーボネート製。フランジは、ニッケル・サテン仕上げ。「IG MAXI SEMI」は、ランプをフランジとは別の位置に設置することも可能です。



Finishes

- 166 Satin nickel

Diffuser

PC Polycarbonate

Cable

Transparent

Suggested light source

220/240V E27

100/120V E26

 Halogen ECO

ICEGLOBE SEMI MAXI max 1x116W

ICEGLOBE SEMI GIANT max 3x116W

 ECO Fluo

 LED

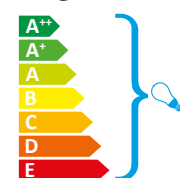

Certification

    Classe I IP20

IG SEMI MAXI

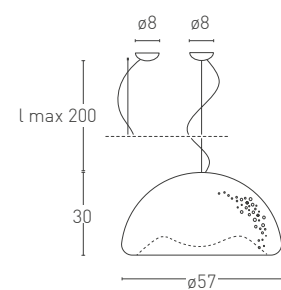

IG SEMI GIANT

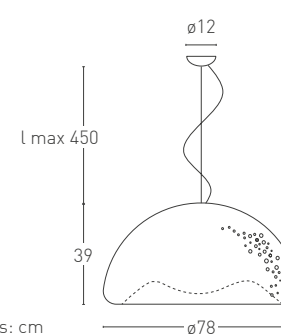

Units: cm



ICEGLOBE BUBBLE 3/5/10 / MINI BUBBLE 3/5/10

Design VillaTosca

ICEGLOBE BUBBLE, sospensione a cascata da 3, 5 o 10 elementi. Sfera realizzata in policarbonato autoestinguente microforato dal diametro di 30 e 20 cm per la versione MINI. Rosone per attacco a soffitto disponibile in bianco opaco con dettagli nichel satinato. Lunghezza cavo massima 3 metri.

ICEGLOBE BUBBLE, cascade suspension version composed of 3, 5 or 10 elements. Sphere made of self-extinguishing micropunched polycarbonate with a diameter of 30 and 20 cm for the MINI version. The canopy is available in matte white finish with details in satin nickel. Cable length: max 3 m.

「アイスグローブ・バブル」は、3/5/10個のエレメントからなるペンダントタイプのシャンデリア。グローブは、30cmと20cm(「ミニ」バージョン)のポリカーボネート製(自己消化性素材)。天井取り付け用フランジカバーは、ニッケルサテンとホワイト半光沢から選択可能。ケーブルの最大の長さは3メートル。

IG BUBBLE 3

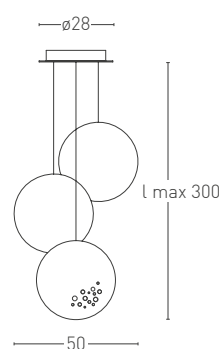

IG BUBBLE 5

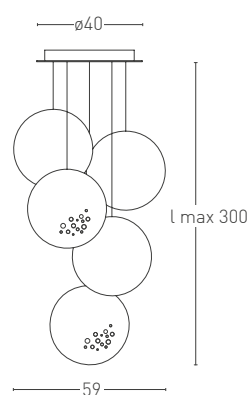

IG BUBBLE 10

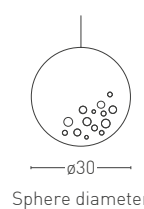
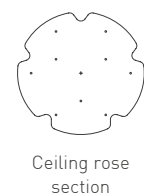
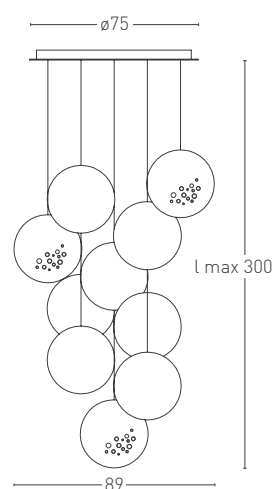

IG MINIBUBBLE 3

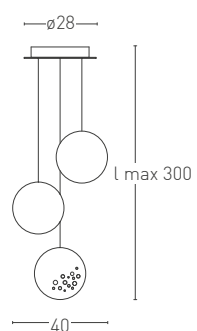

IG MINI BUBBLE 5

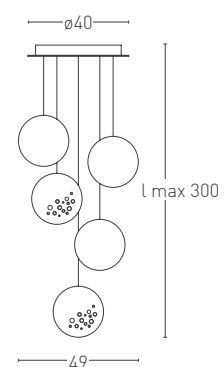

IG MINI BUBBLE 10

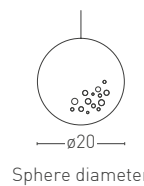
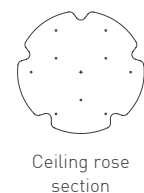
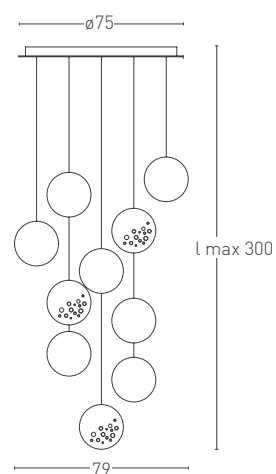

Finishes

Ceiling rose:

○ 106 Matte white

Details:

● 166 Satin nickel

Diffuser

PC Polycarbonate

Cable

Transparent

Suggested light source

220/240V E27

100/120V E26

IG BUBBLE 3/5/10

Halogen ECO max 77W

ECO Fluo

LED

IG MINI BUBBLE 3/5/10

Halogen ECO max 42W

ECO Fluo

LED

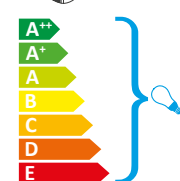

Certification

CE EAC PS E F Classe I IP20



Units: cm

ICEGLOBE MINI 02/S/21

Design VillaTosca

Sfera da 20 cm di diametro realizzata in polycarbonato microforato autoestinguente, declinata nelle versioni da tavolo, a parete e sospensione. Finitura dei dettagli metallici: nichel satinato.

Sphere with a diameter of 20 cm made of self-extinguishing micropunched polycarbonate, available in table, wall and suspension versions. Metal details finish: satin nickel.

自己消化性を持つポリカーボネート製の直径20cmのグローブを持つランプ。テーブルランプ、ウォールタイプ、ペンダントタイプの三種類で構成される製品。ディテール部品はメタル製のニッケル・サテン仕上げ。

IG MINI 02

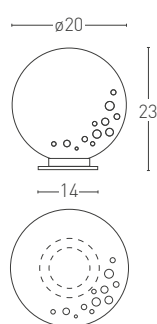

IG MINI 21

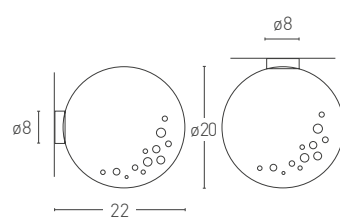

IG MINI S

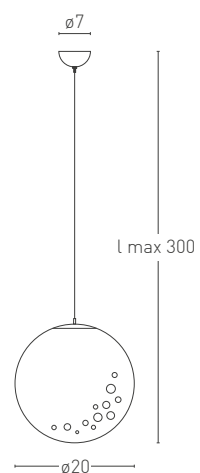

Units: cm



Finishes

- 166 Satin nickel

Diffuser

PC Polycarbonate

Cable

Transparent

Suggested light source

220/240V E27

100/120V E26

Halogen ECO max 42W

ECO Fluo

LED

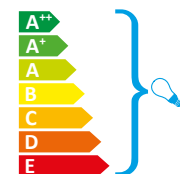

Certification

CE EAC IP20

IG MINI S/21 Classe I

IG MINI 02



ICEGLOBE MINI 21B/21BL

Design VillaTosca

Lampada da parete con stelo in due misure. Diffusore a sfera da 20 cm di diametro realizzato in policarbonato microforato auto-estinguente. Finitura delle parti metalliche: nichel satinato.

Wall lamp with stem available in two sizes. Sphere diffuser with a diameter of 20 cm made of self-extinguishing micropunched polycarbonate. Metal details finish: satin nickel.

二つのサイズを持つ、支柱付きウォールタイプのランプ。自己消化性を持つポリカーボネート製の直径20cmのグローブ。ディテール部品は、メタル製のニッケル・サテン仕上げ。



IG MINI 21B

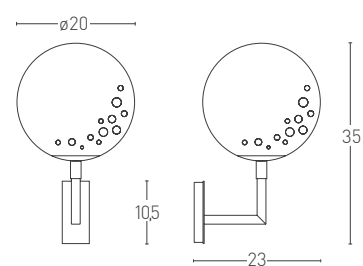

IG MINI 21BL

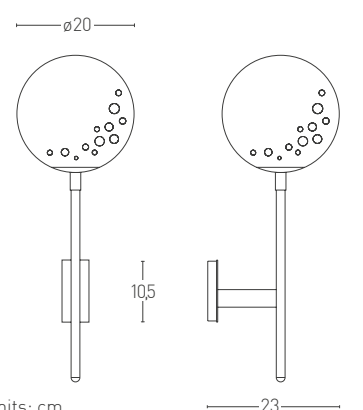

Units: cm



Finishes

- 166 Satin nickel

Diffuser

PC Polycarbonate

Suggested light source

220/240V E27

100/120V E26

 Halogen ECO max 42W

 ECO Fluo

 LED

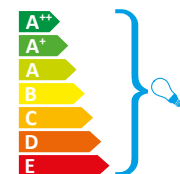

Certification

CE EAC PS E F Classe I IP20



ICEGLOBE MICRO 03/21/21-I/S/S-I

Design VillaTosca

Versioni da tavolo/parete/plafone e sospensione con attacco a rosone o incasso con diffusori in policarbonato microforato autostinguente. Sfere dal diametro di 12 cm. Dettagli metallici con finitura bianco opaco. Nella versione da tavolo, la base e lo stelo sono anch'essi realizzati in metallo laccato bianco opaco.

Table / Wall / Ceiling and Suspension lamp versions with ceiling rose or recessed attachment. Shades made of self-extinguishing micropunched polycarbonate in 12cm diameter. Details in Matte White laquered metal. In Table version, the base and stem are in Matte White laquered metal too.

テーブル/壁/天井/ペンダントと様々なバージョンを持つグローブ直径12cmのランプシリーズ。グローブは自己消化性を持つポリカーボネート製。ディテール部品は、メタル製のホワイト半光沢仕上げ。

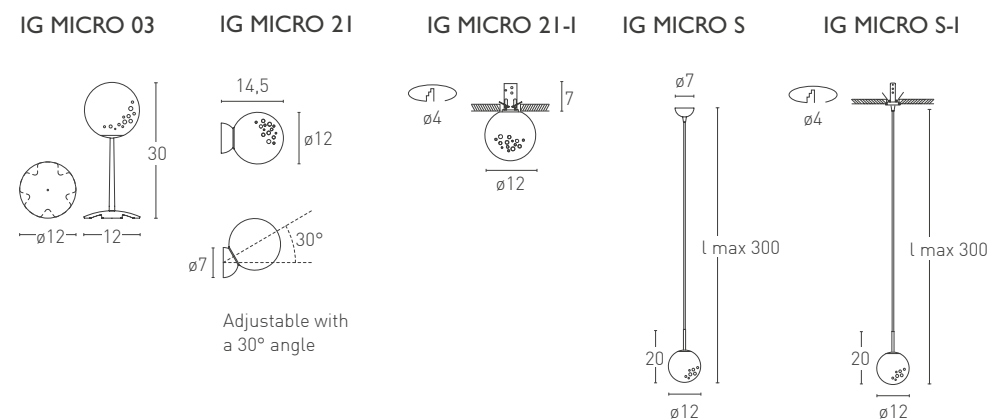

Units: cm



Finishes

○ 106 Matte white

Diffuser

PC Polycarbonate

Cable

White

Suggested light source

100/240V G9

Halogen ECO max 1x33W

LED

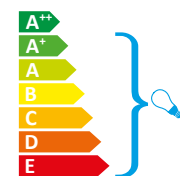

Certification



ICEGLOBE MICRO BUBBLE 4/8/12/16

Design VillaTosca

Versione a sospensioni multiple con rosone in metallo laccato bianco opaco. Sfere dal diametro di 12cm in policarbonato microforato autoestinguente. Configurazione disponibile dai 4 fino ai 16 elementi.

Multiple suspension lamps with ceiling rose in matte white lacquered metal. Shades in 12cm diameter made of self-extinguishing micropunched polycarbonate. Configuration from 4 to 16 spheres available.

アイスグローブ・バブルは4個から16個までのグローブを吊り下げられるペンダントタイプのランプシリーズ。直径12cmのグローブは自己消化機能を持つポリカーボネート製。ディテール部品は、メタル製のホワイト半光沢仕上げ。



IG MICRO BUBBLE 4

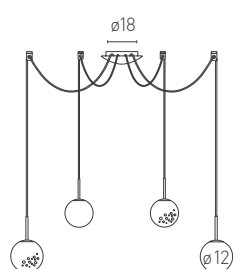

IG MICRO BUBBLE 8

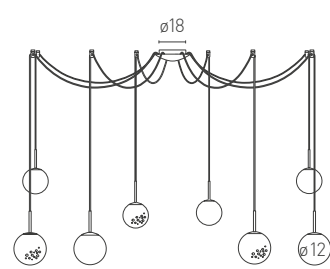

IG MICRO BUBBLE 12

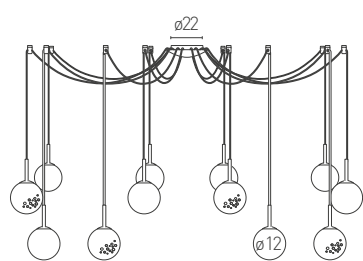

IG MICRO BUBBLE 16

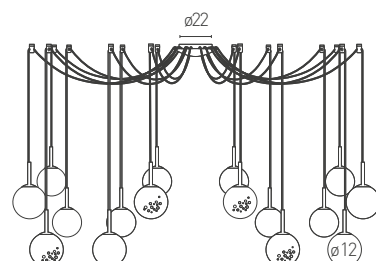

Finishes

○ 106 Matte white

Diffuser

PC Polycarbonate

Cable

White

Suggested light source

100/240V G9

 Halogen ECO

IG MICRO 21/21-I/S/S-I max 1x33W

IG MICRO BUBBLE 4 max 4x33W

IG MICRO BUBBLE 8 max 8x33W

IG MICRO BUBBLE 12 max 12x33W

IG MICRO BUBBLE 16 max 16x33W

 LED

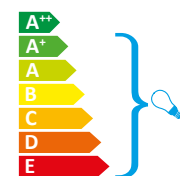

Certification

Units: cm



ICELIGHT

Design VillaTosca



LUCE ARTICA

Collezioni di sospensioni in policarbonato microforato e rosone in ABS bianco opale. Disponibile anche nella versione a sospensione multipla con struttura in metallo verniciato bianco opaco.

ARTIC LIGHT

Collection of suspensions in micro-punched polycarbonate with ceiling rose in ABS opal white. Also available as multiple suspension with metal structure painted in matte white.

北極からのひかり

ビーズ状のポリカーボネート製のグローブを持つペンダントタイプのシリーズ。フランジはABS樹脂製オパール・ホワイト。複数のグローブ（3体あるいは5体）のマルチ・ペンダントバージョンも用意しています。この筐体は、メタル製ホワイト半光沢塗装。

ICELIGHT 20/30/45/60/60 SEMI

Design VillaTosca

ICELIGHT è una collezione di lampade a sospensione che sfrutta al massimo le potenzialità dello stampaggio polimerico e che standardizza il prodotto per renderlo semplice e versatile per il settore contract e grandi forniture. L'attacco a soffitto è realizzato interamente in ABS bianco opaco ed è standard per tutta la collezione. La sfera è disponibile nei diametri: 20, 30, 45, 57 cm e nella versione SEMI da 57 cm di diametro.

ICELIGHT is a collection of suspension lamps in polymer moulding, simple and versatile for contract and supplies sectors. The ceiling rose is entirely in matte white ABS, standard for all the collection. Sphere diameters: 20, 30, 45, 57 cm and SEMI version in 57 cm diameter.

「アイスライト」は、樹脂成型の可能性を最大限に生かしたペンダントランプシリーズです。大小用意されたシンプルなデザインは様々な空間で自由な使い方が可能で、コントラクト等の大規模利用に最適です。全てのサイズに採用されているフランジカバーとランプボディはホワイト半光沢のABS製。グローブ部は、直径20、30、45、57cmと半球体57cmの5種類が用意されています。

(品名:20、30、45、60、SEMI60)



Finishes

○ ABS White

Diffuser

PC Polycarbonate

Cable

Transparent

Suggested light source

220/240V E27

100/120V E26

Halogen ECO

IL 20 max 42W

IL 30 max 77W

IL 45/60/60S max 116W

ECO Fluo

IL 20 max 11W

ECO Fluo

IL 30/45/60/60S max 24W

LED

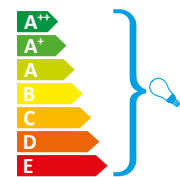

Certification

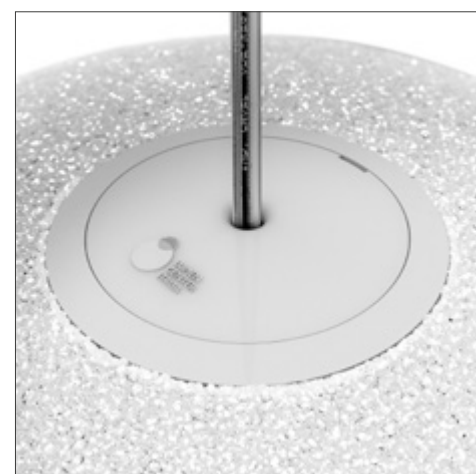
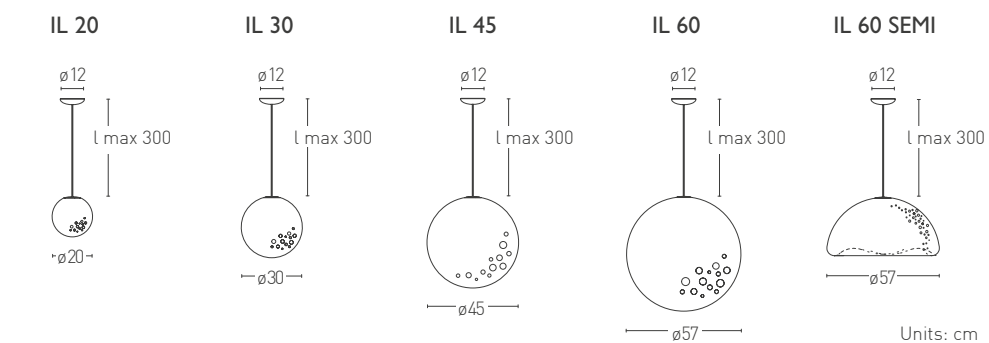

ICELIGHT PENDANT 3/5

Design VillaTosca

Attacco a soffitto dotato di 3 o 5 bracci disposti a raggiera che consente la libera configurazione di sospensioni utilizzando 3 o 5 sfere a scelta tra i diametri 20, 30, 45 cm della collezione ICELIGHT. Finitura bianco opaco.

Ray system ceiling rose with 3 or 5 arms; the lamp allows the free configuration of the suspensions settings using 3 or 5 spheres (diameters 20, 30, 45 cm) of ICELIGHT collection. Matte white finish.

天井取り付けベースに3つあるいは5つのアームを備えたペンダントタイプのランプ。アイスライトシリーズのグローブ(20、30、45 cm)から組み合わせが自由に選択できます。塗装はホワイト半光沢。



IL PEN 3

IL PEN 5

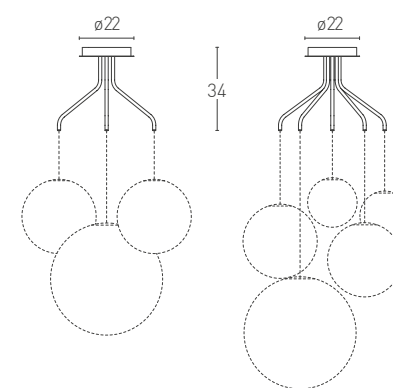

Units: cm

ICELIGHT PENDANT COMPOSITION

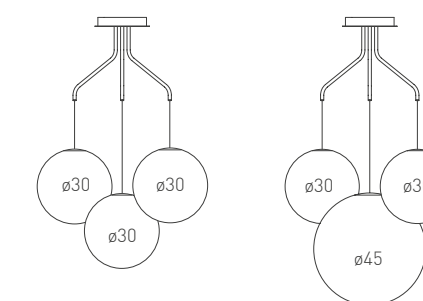

ILPEN3+3xIL30

ILPEN3+2xIL30+IL45

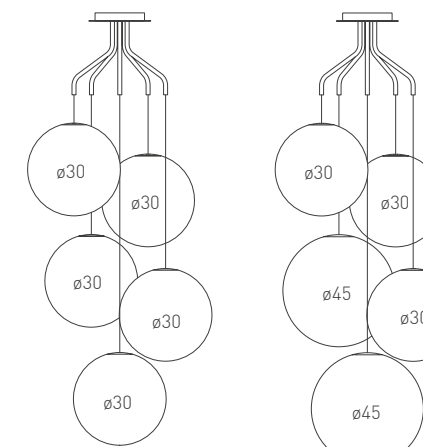

ILPEN5+5xIL30

ILPEN5+3xIL30+2xIL45



Finishes

○ 106 Matte white

Diffuser

PC Polycarbonate

Cable

Transparent

Certification



SUMO COLLECTION

Design VillaTosca

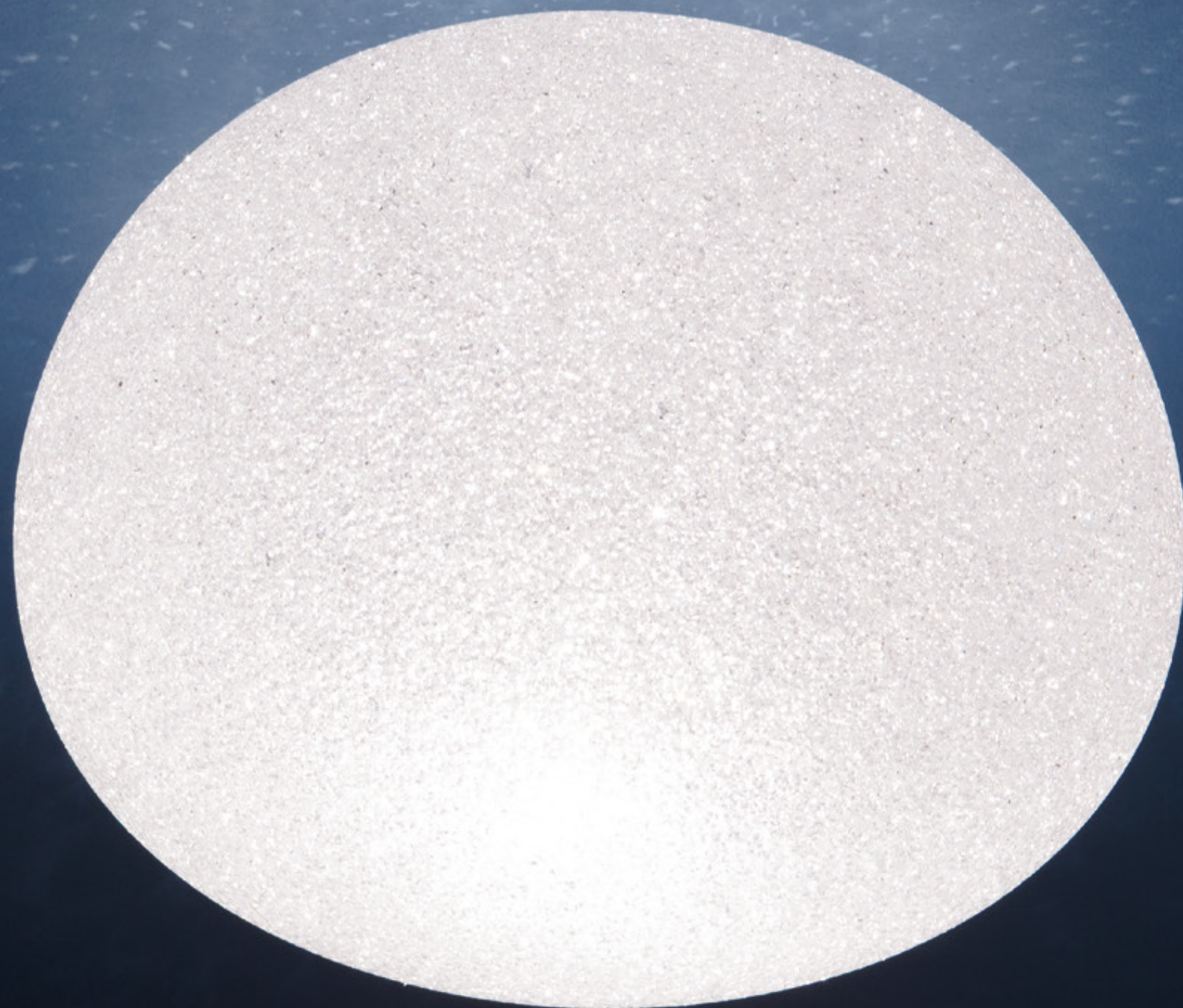

LUCE DALL'ORIENTE

Metaforicamente ispirate alle forme del corpo dei lottatori di Sumo, la divertente collezione di sospensioni, applique e lampade da terra con diffusore in policarbonato microforato è disponibile in varie tipologie e dimensioni. Finitura delle strutture bianco opaco.

LIGHT FROM THE FAR EAST

Metaphorically inspired to Japanese wrestlers body, this funny collection of suspensions, wall and floor lamps with micropunched polycarbonate diffuser, is available in different sizes and typologies. Matte white frame finish.

東洋からの光

相撲の力士の体型にヒントを得たユニークなシリーズ。ビーズ状のポリカーボネートを成型し作られたグローブは大小さまざまなサイズを持ち、用途もシーリング/ウォール、ペンダント、フロアと幅広い用途でお選び頂けます。筐体の仕上げはホワイต์半光沢。

SUMO S/M/L/X

Design VillaTosca

Sospensioni in policarbonato microforato, realizzate in tre forme e 4 differenti diametri. Rosone realizzato in ABS bianco opaco.

Suspension lamps in micropunched polycarbonate, three sizes and 4 different diameters. Ceiling rose in matte white ABS.

ピース状のポリカーボネート製グローブのペンダントランプ、3種類の形状から成る4つのサイズ構成。フランジはABS製（色/ホワイト半光沢）。

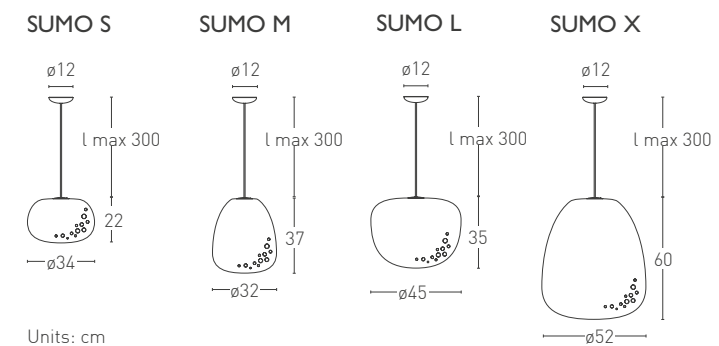

Finishes

○ ABS White

Diffuser

PC Polycarbonate

Cable

Transparent

Suggested light source

220/240V E27

100/120V E26

LED

SUMO S

Halogen ECO max 1x77W

ECO Fluo

SUMO M/L/X

Halogen ECO max 116W

ECO Fluo

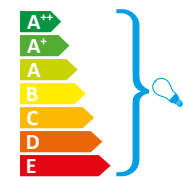

Certification

CE EAC PS E F IP20



SUMO 21/M21/L21

Design VillaTosca

Applique e plafoniere in policarbonato microforato. Attacco realizzato in metallo verniciato bianco opaco.

Wall and ceiling lamps in micropunched polycarbonate. Metal frame is powder coated in matte white.

ビーズ状のポリカーボネート製グローブのシーリング/ウォールランプ。スチール製の筐体はホワイト半光沢の塗装仕上げ。



Finishes

- 106 Matte white

Diffuser

PC Polycarbonate

Suggested light source

220/240V E27

100/120V E26

ECO Fluo

LED

SUMO 21

Halogen ECO max 77W

SUMO M21/L21

Halogen ECO max 116W

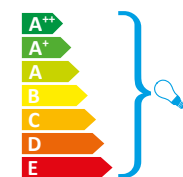

Certification

CE EAC PS E F Classe I IP20

SUMO 21

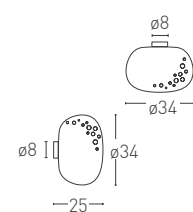

SUMO M21

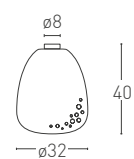

SUMO L21

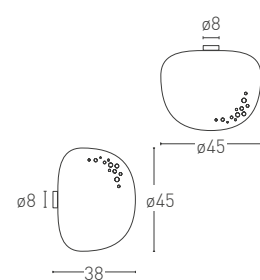

Units: cm



SUMO 02/M02/L02/X02

Design VillaTosca

Lampade da tavolo realizzate in policarbonato microforato. Base realizzata in metallo verniciato bianco opaco. Regolatore di intensità luminosa incluso.

Table lamps in micropunched polycarbonate. Metal frame is powder coated in matte white. Dimmer included.

ピース状のポリカーボネート製グローブのテーブルランプ。スチール製の筐体はホワイト半光沢の塗装仕上げ。調光機能付き。

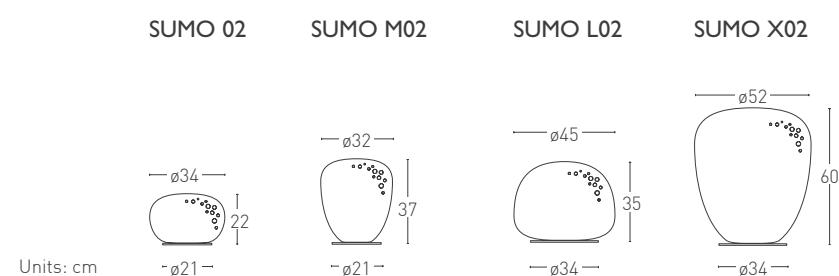

Finishes

○ 106 Matte white

Diffuser

PC Polycarbonate

Dimmer

SUMO L02 / X02 Included

Suggested light source

220/240V E27

100/120V E26

SUMO 02/M02

Halogen ECO max 77W

ECO Fluo

LED

SUMO L02/X02

Halogen ECO max 77W

LED dimmable min 5W

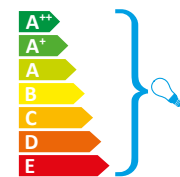

Certification



CORAL COLLECTION

Design VillaTosca

CORALLI BAROCCHI

CORAL, la serie che coniuga esteticamente lo stile barocco con le forme naturali dei coralli, offre diverse tipologie di prodotti a sospensione, a plafone e parete nelle misure "super" e "mini".

Icona della collezione, il candeliere a 8 luci declinato anche nella versione a 16 luci.

BAROQUE STYLE CORALS

CORAL, the collection which combines baroque style with the natural shapes of coral offers a selection of fittings designed for direct mounting on ceilings and walls or for suspended mounting. Available in two designated sizes "super" and "mini".

The core of the collection is a chandelier which is available in an eight or a sixteen lamp version.

バロックスタイルのサンゴ

「コーラル」は、バロックスタイルと自然の形を融合したデザインのシリーズです。シーリングタイプ、ウォールタイプの様に直接設置可能なものから、シャンデリアタイプまで幅広く展開しています。このシリーズの中心は、8灯タイプと16灯タイプの二種類のシャンデリアで構成されています。他に「スーパー」と「ミニ」の2サイズが選べます。

CORAL / CORAL P

Design VillaTosca

CORAL è la versione a 8 luci che dà origine all'intera serie. Realizzata in metallo laccato, è disponibile nelle finiture: nero lucido, bianco lucido, verde chartreuse, rosso, foglia oro e foglia argento. Diffusori realizzati in vetro Pyrex serigrafato.

CORAL P, lampada a plafone a 6 luci. Realizzata in metallo laccato, è disponibile nelle finiture: nero lucido, bianco lucido, verde chartreuse, rosso, foglia oro e foglia argento. Diffusori realizzati in vetro Pyrex serigrafato.

CORAL is a 8 light chandelier that forms the basis of the collection. Made of lacquered metal, it is available in glossy black, glossy white, chartreuse green, red, gold foil and silver foil. The diffusers are made of etched Pyrex glass.

CORAL P, the ceiling lamp with 6 light. Made of lacquered metal, it is available in glossy black, glossy white, chartreuse green, red, gold foil and silver foil. The diffusers are made of etched Pyrex glass.

「コーラル」は8灯シャンデリアタイプで、このシリーズ全体の基本となっています。メタルの塗装仕上げで、ブラック光沢、ホワイト光沢、ライトグリーン、レッド、金箔、銀箔が選べます。セードはバイレックスにエッチング加工が施してあります。

「コーラル P」は、6灯式シーリングタイプのランプ。メタル製の本体は、以下の塗装から選択できます。ブラック光沢、ホワイト光沢、レッド、ライトグリーン、金箔仕上げ、銀箔仕上げ。セードは、バイレックスのエッチング仕上げ。

CORAL

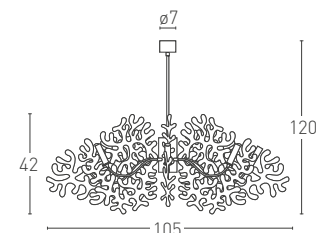

CORAL P

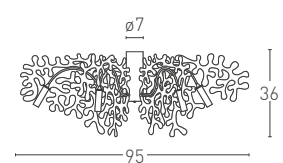

Units: cm



Finishes

- 112 Glossy black
- 114 Glossy white
- 119 Chartreuse green
- 120 Red
- 130 Gold foil
- 131 Silver foil

Diffuser

Etched Pyrex

Suggested light source

100/240V G9

LED

Halogen ECO

CORAL max 8x33W

CORAL P max 6x33W

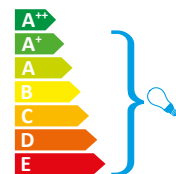

Certification

CE EAC PS E F Classe I IP20



SUPERCORAL 8L/16L

Design VillaTosca

SUPERCORAL 8L e 16L, grande lampadario da 8 o 16 luci dal diametro di 140 cm. Realizzata in metallo laccato, é disponibile nelle finiture: nero lucido, bianco lucido, verde chartreuse, rosso, foglia oro e foglia argento. Diffusori realizzati in vetro Pyrex serigrafato.

SUPERCORAL 8L and 16L is a large chandelier (140 cm diameter). Made of lacquered metal, it is available in the following finishes: glossy black, glossy white, chartreuse green, red, gold foil and silver foil. The diffusers are made of etched Pyrex glass.

「スーパーコーラル8L/16L」は、8灯及び16灯の直径140cmのシャンデリアタイプの照明です。メタル製の本体の仕上げは、ブラック光沢、ホワイト光沢、ライトグリーン、レッド、金箔仕上げ、銀箔仕上げ。セードはパイレックスにエッチング加工が施してあります。

SUPERCORAL 8L

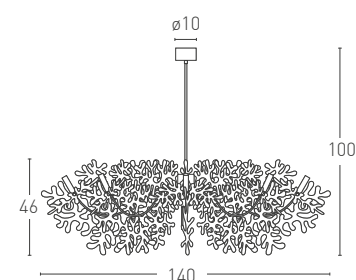

SUPERCORAL 16L

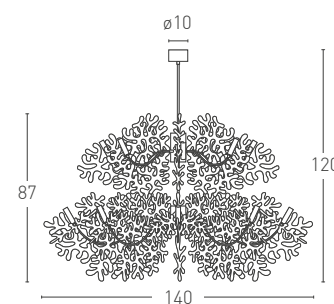

Units: cm



Finishes

- 112 Glossy black
- 114 Glossy white
- 119 Chartreuse green
- 120 Red
- 130 Gold foil
- 131 Silver foil

Diffuser

Etched Pyrex

Suggested light source

100/240V G9

 LED

 Halogen ECO

SUPERCORAL 8L max 8x48W

SUPERCORAL 16L max 16x33W

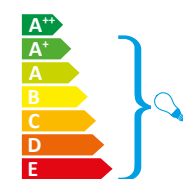

Certification

CE EAC   Classe I IP20



MINICORAL S/A/P

Design VillaTosca

MINICORAL è una serie di piccoli punti luce a sospensione, a parete e plafone realizzati in metallo laccato e disponibili nelle finiture: nero lucido, bianco lucido, verde chartreuse, rosso, foglia oro e foglia argento. Diffusori realizzati in vetro Pyrex serigrafato.

MINICORAL is a collection of small spot lights, in suspension, ceiling and wall lamp version. Made of lacquered metal it is available in glossy black, glossy white, chartreuse green, red, gold foil and silver foil. The diffusers are made of etched Pyrex glass.

「ミニコーラル」は、シャンデリア、シーリング、ウォールタイプが揃った小さなスポット照明コレクション。メタルの塗装仕上げで、ブラック光沢、ホワイト光沢、ライトグリーン、レッド、金箔、銀箔が選べます。セードは、パイレックスのエッチング仕上げ。



Finishes

- 112 Glossy black
- 114 Glossy white
- 119 Chartreuse green
- 120 Red
- 130 Gold foil
- 131 Silver foil

Diffuser

Etched Pyrex

Cable

Transparent

Suggested light source

100/240V G9

Halogen ECO max 48W

LED

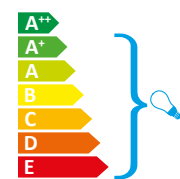

Certification

CE ENEC PS E F Classe I IP20



MINICORAL S

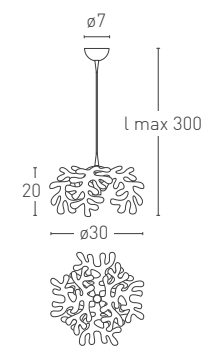

MINICORAL A

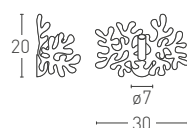

MINICORAL P

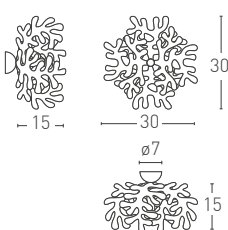

Units: cm



LEAVES

Design VillaTosca

VEGETAZIONE LUMINOSA

LEAVES è una divertente collezione di sospensioni, applique e plafoniere dal colorato fogliame metallico. Le molteplici e diverse versioni si adattano perfettamente ad ambienti giovani, accoglienti e familiari. Disponibili nei colori: rosso lucido, verde chartreuse, nero lucido, bianco lucido, foglia oro e foglia argento.

LIGHTING GREENERY

LEAVES is a pleasant collection of suspension lamps, wall lamps and ceiling lamps supplied with a colored metal foliage. The various versions are perfectly suited for use in familiar, comfortable and young settings. Available in the colors: glossy red, chartreuse green, glossy black, glossy white gold/silver foil.

緑豊かなあかり

「リーブス」は、鮮やかな色合いの金属製の群葉が特徴的な楽しいシリーズです。ペンダントタイプ、ウォール/シーリングタイプなど多様なバージョン展開により、若者向けにも、普段使いのくつろぎ空間にも完璧にマッチします。カラー展開は、レッド光沢、ライトグリーン光沢、ブラック光沢、ホワイト光沢、金箔、銀箔仕上げの6種類を用意しております。

LEAVES S/21

Design VillaTosca

LEAVES è la più piccola versione della serie, disponibile come sospensione o applique/plafone. Realizzata in fogli di metallo tagliati a laser e successivamente modellati a mano, è disponibile nelle finiture: nero lucido, bianco lucido, verde chartreuse, rosso, foglia oro e foglia argento. Per la versione a sospensione, è possibile decentrare l'attacco a soffitto rispetto al rosone o ordinare un rosone con doppia uscita per collegare due lampade.

LEAVES is the smallest version of the collection, available as suspension or wall/ceiling lamp. Made of metal leaves shaped by hand. Available in glossy black, glossy white, chartreuse green, red, gold and silver foil finishes. The suspension lamps may be mounted on the ceiling off centre with respect to the ceiling rose alternatively a double socket ceiling rose is available to facilitate the connection of two lamps.

「リーフス」シリーズの中で一番小さな製品。ペンダント/シーリング/ウォールタイプの三種類に対応することができます。レーザーカットされたメタルを手作業で折り曲げています。塗装は、ブラック光沢、ホワイト光沢、ライトグリーン、レッド、金箔仕上げ、銀箔仕上げの中から選択できます。ペンダントタイプの場合は、フランジから別の位置に配置することができます。さらに、オーダーでひとつのフランジから二体のランプに電源供給することも可能です。



LEAVES S

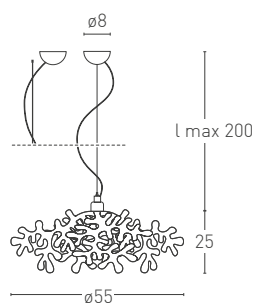

LEAVES 21

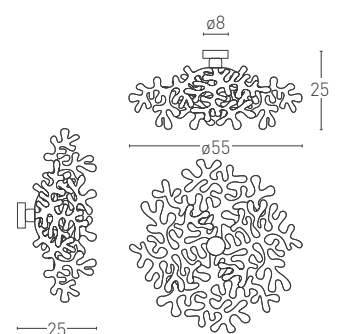

Units: cm



Finishes

- 112 Glossy black
- 114 Glossy white
- 119 Chartreuse green
- 120 Red
- 130 Gold foil
- 131 Silver foil

Cable

Transparent

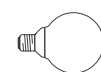

Light source

220/240V E27

100/120V E26

LEAVES S

ECO Fluo Globe ø100 mm max 24W

LED (suggested)

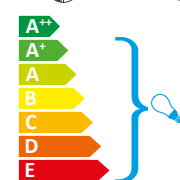

Suggested light source

220/240V E27

100/120V E26

LEAVES 21

Special Mirror Silver max 100W

LED Special Mirror Silver

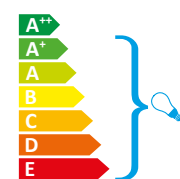

Certification

CE EAC PS E F Classe I IP20



MIDILEAVES / SUPERLEAVES

Design VillaTosca

MIDILEAVES e SUPERLEAVES sono le versioni a sospensione rispettivamente dal diametro di 75 e 105 cm. Realizzata in fogli di metallo tagliati a laser e successivamente modellati a mano, è disponibile nelle finiture: nero lucido, bianco lucido, verde chartreuse, rosso, foglia oro e foglia argento.

MIDILEAVES and SUPERLEAVES are the suspension versions available respectively with a diameter of 75 and 105 cm. Made of laser cut metal leaf shaped by hand, available in glossy black, glossy white, chartreuse green, red, gold and silver foil finishes.

「ミディリーブス(直径75cm)」、「スーパーリーブス(直径105cm)」は、シャンデリアタイプのバージョンです。レーザーカットされたメタルを手作業で折り曲げています。塗装は、ブラック光沢、ホワイト光沢、ライトグリーン、レッド、金箔仕上げ、銀箔仕上げの中から選択できます。

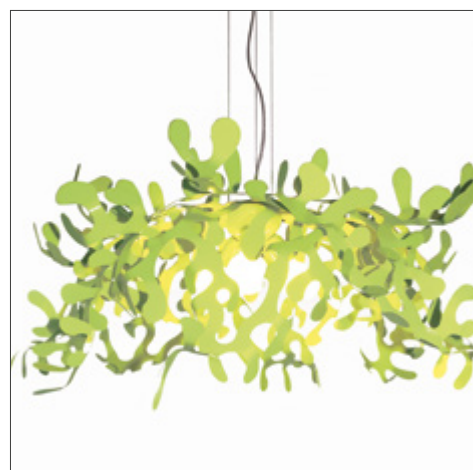

MIDILEAVES

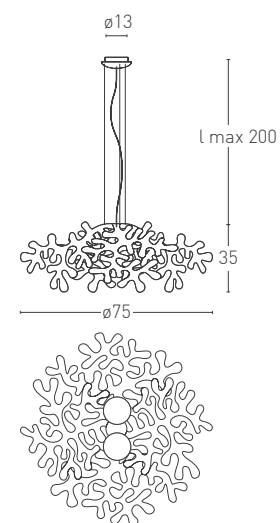

SUPERLEAVES

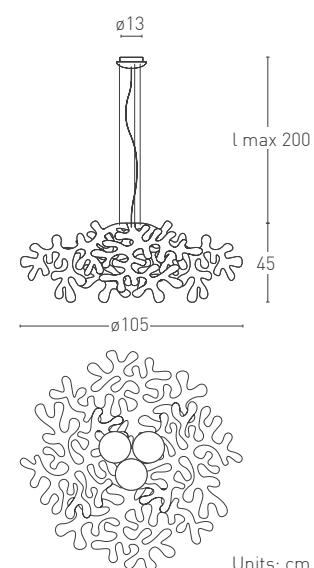

Finishes

- 112 Glossy black
- 114 Glossy white
- 119 Chartreuse green
- 120 Red
- 130 Gold foil
- 131 Silver foil

Cable

Transparent

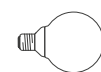

Light source

220/240V E27
100/120V E26
ECO Fluo Globe ø100 mm
MIDILEAVES max 2x24W
SUPERLEAVES max 3x24W
LED (suggested)

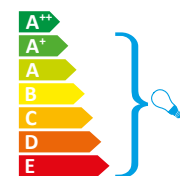

Certification

CE EAC PS E F Classe I IP20



RAMAGE

Design Enrico Azzimonti

FOGLIE HI-TECH

Prolunga sulle pareti un effimero gioco di luci ed ombre il paralume di RAMAGE, sospensione disegnata da Enrico Azzimonti che riproduce un lussureggiante fogliame tecnologico. Ogni singola foglia, in metallo tagliato al laser, è modellata manualmente da abili artigiani in grado di creare unici ed irripetibili pezzi dalle organiche forme naturali.

HI-TECH LEAVES

RAMAGE, suspension lamp designed by Enrico Azzimonti. Its lampshade extends on walls an ephemeral game of light and shadows. It reproduces a lush hi-tech foliage, where each leaf, in laser-cut steel, is shaped by skilled craftsmen who create unique and unrepeatable pieces with natural forms.

ハイテクの木の葉

「ラマーヂュ」は壁に投射されるはかどない光と影の楽しみを生み出すペンダントタイプのランプです。メタルプレートからレーザーカットされ作り出される木の葉のささやきを感じさせるセード部は熟練の職人の手によって自然な形にボリュームを与えられ、一品ごとが唯一無二の作品となります。

RAMAGE

Design Enrico Azzimonti

Lampada a sospensione con paralume metallico. La doppia sorgente luminosa LED collocata al centro del corpo lampada consente di illuminare sia verso l'alto sia verso il basso, creando un divertente gioco di luci ed ombre. Finiture: bianco opaco e oxyde FT. Alimentatore elettronico dimmerabile incluso.

Suspension with metallic diffuser. The double LED light source is placed at the center of the body lamp and allows to light up either upwards or downwards, creating a funny game of lights and shadows each light source). Finishes: matte white and oxyde FT. Dimmable electronic driver included

メタル製セードのペンダントランプ。二重のLED光源を本体の中心に内蔵しております。これによって上部と下部の両方の組み合わせで光と影を楽しむことができます。塗装は、ホワイト半光沢、梨地状のファインテクスチャーのFTオレンジの2種類。調光可能な電源を内蔵。

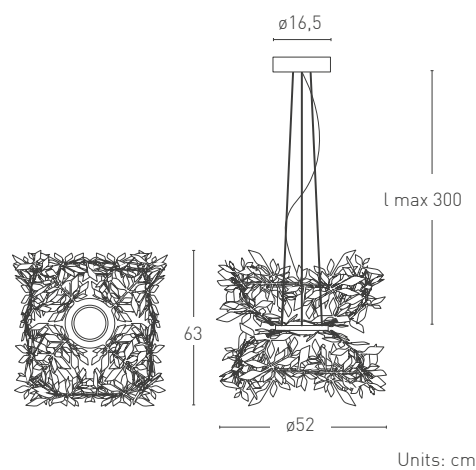

Units: cm



Finishes

- 106 Matte white
- 117 FT Oxyde

Electronic driver

RAMAGE: Dimmable included TRIAC

Light source **LED**

220/240V

LED UP - 17,5W
1750lm 3000K CRI>90

LED DOWN - 17,5W
1750lm 3000K CRI>90

A

Certification

CE EAC F IP20 Classe I



CLASSIC

QUADRO LED VII (RE-EDITION 2014)

Design Jacques Adnet, 1929/2014

Lampada da tavolo icona della collezione Classic LCI disegnata nel 1929 da Jacques Adnet esponente di spicco del Modernismo francese e, in quegli anni, direttore de "La Compagnie des Arts Francais" in cui operarono Francois Jourdain, Charlotte Perriand e Georges Jouve. QUADRO, da sempre a catalogo LCI, fu realizzata su decisione dell'allora direttore artistico Gilles Derain, tra i primi estimatori e studiosi dei movimenti modernisti francesi. La lampada è realizzata in tubolare d'ottone con placcatura elettrolitica in Palladio o in Oro Zecchino. Diffusori in resina acrilica sabbata. Base in marmo nero Marquina e marmo bianco di Carrara, cavo elettrico in tessuto nero. Pulsante di accensione con regolatore di intensità luminosa. Sorgenti luminose LED integrate.

Table lamp, icon of the Classic Collection LCI, designed in 1929 by Jacques Adnet great exponent of French Modernism and director of the "La Compagnie des Arts Francais" where Francois Jourdain, Charlotte Perriand and Georges Jouve also served. QUADRO, since ever in LCI catalogue, was built upon a decision by Gilles Derain, LCI Art Director at that time and one of the French modernist movements estimators. The lamp is made with a tube shaped structure in brass with electrolytic plating in Palladium or Gold. Diffusers in sand acrylic resin. Base in black Marquina marble or white Carrara marble and electric cable in black fabric. Dimmable power-button. Embedded LED light sources.

1929年にフランスのモダニズムの第一人者であるジャック・アドゥネによってデザインされたLCIのクラシック・コレクションを代表するテーブルランプです。当時彼は 'La Compagnie des Arts Francais' (芸術性の高い家具メーカー) のディレクターとして、シャルロット・ペリアン、フランシス・ジオルダン、ジョルジュ・ジューヴら錚々たるメンバーを指揮していました。「クアドロ」は常にLCIのカタログの中に位置していますが、始まりはフランスモダニズム運動の研究者としても第一人者でもあったアートディレクター、ジル・ドレンの判断による復刻でした。ランプの筐体は管状の真鍮をパラジウムメッキで仕上げたもので、発光部はつや消し仕上げのアクリル製。台座は大理石（黒マルキナ石）、電源コードは布カバー仕様。電源ボタンは調光機能を兼ねています。光源はLED。

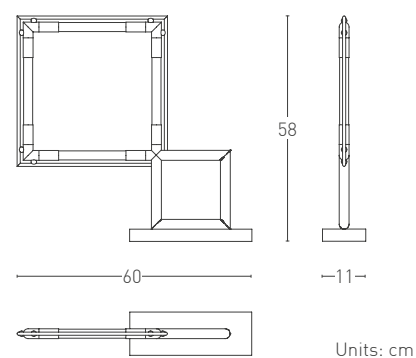

Units: cm

Finishes

- 160 Palladium + ● Black Marquina
- 154 Gold + ○ White Carrara

Diffuser

RA acrylic resin

Cable

Black fabric

Electronic driver

Dimmable included

Light source

LED

LED 110/240V 8x2W
2000lm 2700K CRI>90

A

Certification

CE EAC PS E F IP20



MJA LIMITED EDITION

Design Jacques Adnet, 1930

Lampada da tavolo disegnata nel 1930 da Jacques Adnet esponente di spicco del Modernismo francese e, in quegli anni, direttore de "La Compagnie des Arts Francais" in cui operarono Francois Jourdain, Charlotte Perriand e Georges Jouve. MJA (Memory of Jacques Adnet) entrò in produzione solo nel 2005; in precedenza non fu mai realizzata se non a livello di prototipo. La lampada, composta da una calotta sferica poggiata su un piedistallo dalla forma quadrangolare, è realizzata in ottone con finitura Palladio o in Oro Zecchino.

Table lamp designed in 1930 by Jacques Adnet great exponent of French Modernism. During those years he was director of "La Compagnie des Arts Francais" where Francois Jourdain, Charlotte Perriand and Georges Jouve worked too. MJA (Memory of Jacques Adnet) in production from 2005, was earlier only realized as a prototype. The lamp, with a spherical cap resting upon a quadrangular base, is made of brass with a Palladium or Gold finishes.

1930年にフランスのモダニズムの第一人であるジャック・アドゥネによってデザインされたテーブルランプです。当時彼は「La Compagnie des Arts Francais」(芸術性の高い家具メーカー)のディレクターとして、シャルロット・ペリアン、フランシス・ジョルダン、ジョルジュ・ジュヴら錚々たるメンバーを指揮していました。MJA (Memory of Jacques Adnet (ジャック・アドゥネの記憶))は試作のみで生産は実現しなかった幻の作品を2005年に蘇らせたものです。四角形の台座の上に半球のセードを合わせた構成のランプで、真鍮製、パラディウムメッキ仕上げ。

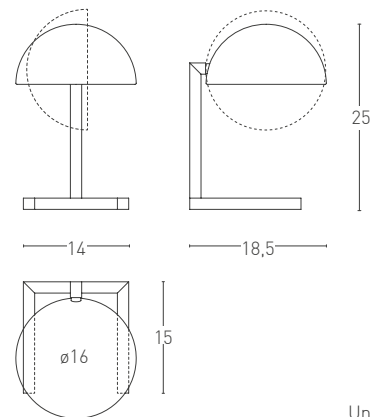
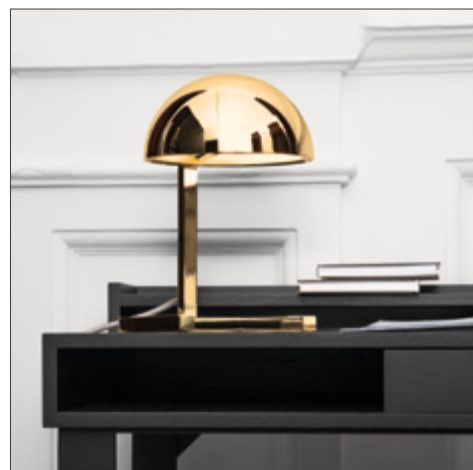

Units: cm



Finishes

- 160 Palladium
- 154 Gold

Cable

Transparent

Suggested light source

220/240V E14

100/120V E12

Halogen ECO max 30W

LED

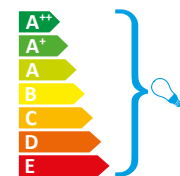

Certification



MEMORY STUDIO LIMITED EDITION

Design VillaTosca 2005

MEMORY STUDIO nasce come omaggio al designer francese Jacques Adnet e ne declina il progetto - rieditato da LUMEN CENTER ITALIA e chiamato MJA - in una versione da tavolo più alta con snodi sia nello stelo che nella calotta. Finiture disponibili sia in Palladio che in Oro Zecchino. Cavo trasparente.

MEMORY STUDIO was born as a tribute to the French designer Jacques Adnet and decline his project - reissued by LUMEN CENTER ITALIA and called MJA - in a higher table version and with junctions in the stem and in the shell.

Available finishes in Palladium and Gold. Transparent cable.

「メモリー・ストゥーディオ」は、フランス人デザイナー:ジャック・アドゥネに敬意を表して生まれた作品。ルーメンセンターによって「MJA (エムジェイエー)」として再版された作品のバリエーションです。位置調整の可能な長い支柱を持ったデスクランプです。

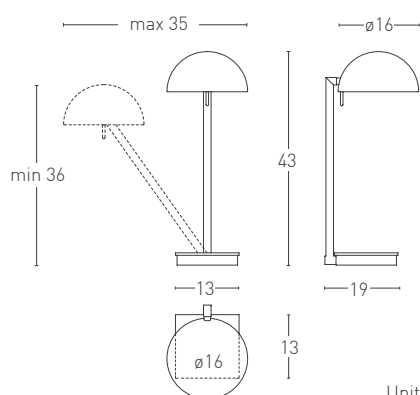

Units: cm

Finishes

- 160 Palladium
- 154 Gold

Cable

MEMORY STUDIO Transparent

Suggested light source

220/240V E14
100/120V E12

Halogen ECO max 30W

LED

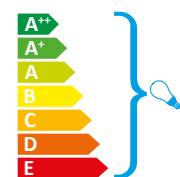

Certification

CE EAC PS E F IP20

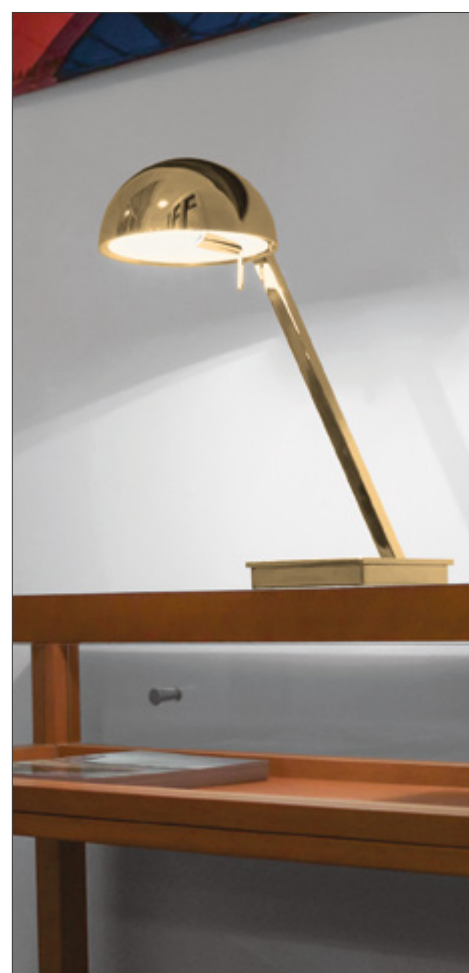

OMEGA LED

Design Gill Derain, 1984/2016

OMEGA intesa come conclusione perfetta di un lavoro iniziato con la prima lettera l'Alfa. La lampada da tavolo OMEGA è un semicerchio in metallo che richiama l'incontro tra il cielo e la terra. Diffonde una luce di altissima qualità (LED **luum**® CRI>97) con spettro luminoso molto simile a quello della luce naturale.

*OMEGA understood as a perfect end to a job started with the first letter "Alfa". The OMEGA table lamp is a metal semi-circle that recalls the encounter between heaven and earth. It uses **luum**® LED light source (CRI>97) with a very high quality light and with a bright spectrum similar to natural light.*

「オメガ」はα（アルファ）の文字から始まった仕事の最後を締めくくるに相応しい照明です。このテーブルランプは金属製の半球の形を持ち、それは天と地の出会いを連想させます。光源には自然光にとても近い高品質の光をお届けできるLED (LED **luum**® CRI>97) を使用しております。

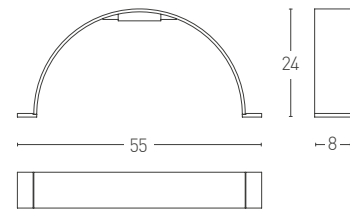

Units: cm

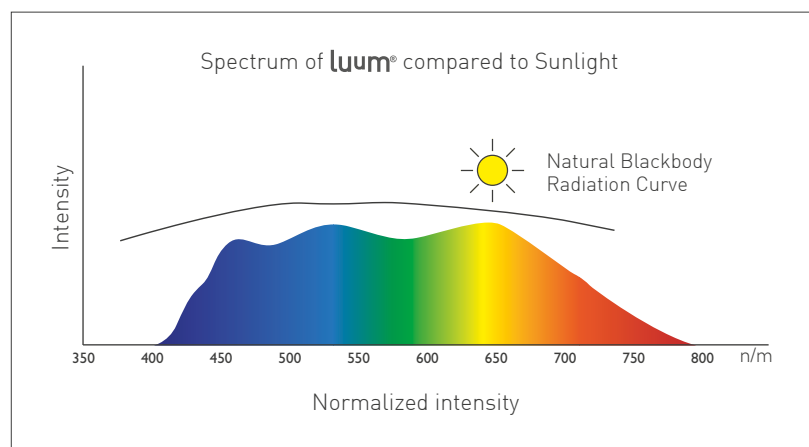
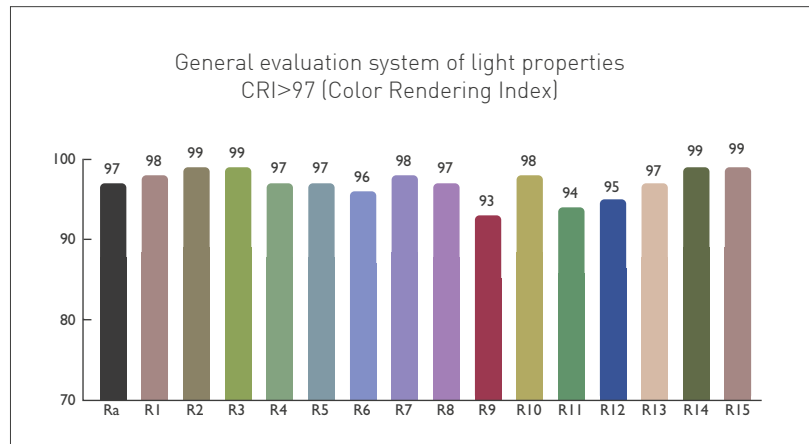

Finishes

- 102 Matte black
- 106 Matte white

Cable

Black / Transparent

Electronic driver

Included

Electronic driver

Dimmable included

Light source

LED

LED **luum® 12W 100/240V**
730lm 2700K CRI>97

A

Certification



WASHINGTON LED

Design Jean-Michel Wilmotte, 1983/2015

Disegnata nel 1983 dall'architetto francese Jean-Michel Wilmotte per l'Ambasciata Francese di Washington DC, da sempre celebra l'eleganza istituzionale della Collezione Classic LUMEN CENTER ITALIA. Realizzata in metallo cromato o laccato con polveri epossidiche.

Diffonde una luce di altissima qualità (LED **luum**® CRI>97) con spettro luminoso molto simile a quello della luce naturale. Regolatore di intensità luminosa incluso.

Designed in 1983 by the French architect Jean-Michel Wilmotte for the French Embassy in Washington DC. It keeps on celebrating the institutional elegance of the Classic Collection of LUMEN CENTER ITALIA. Made in chrome metal or in lacquered metal with epoxy powders.

*It uses **luum**® LED light source (CRI>97) with a very high quality light and with a bright spectrum similar to natural light. Dimmer included.*

1983年にワシントンDCのフランス大使館のためにフランスの建築家ジャン=ミッシェル・ウィルモットによってデザインされたLCIのクラシックコレクションの中でも特にエレガンスを感じさせるデスクランプです。

筐体はスチール製で、カラーはクロムメッキとエポキシ樹脂塗装仕上げのブラック。

光源には自然光に近いスペクトラムを持つ非常に高品質のLED(**luum**® CRI>97)を採用しています。

調光機能内蔵。

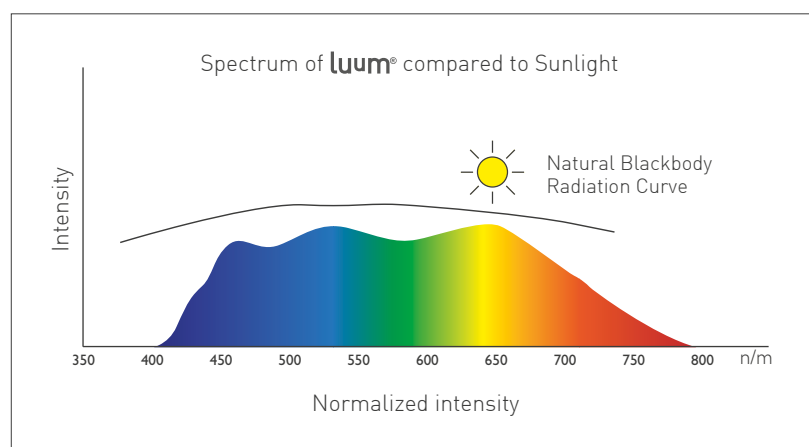
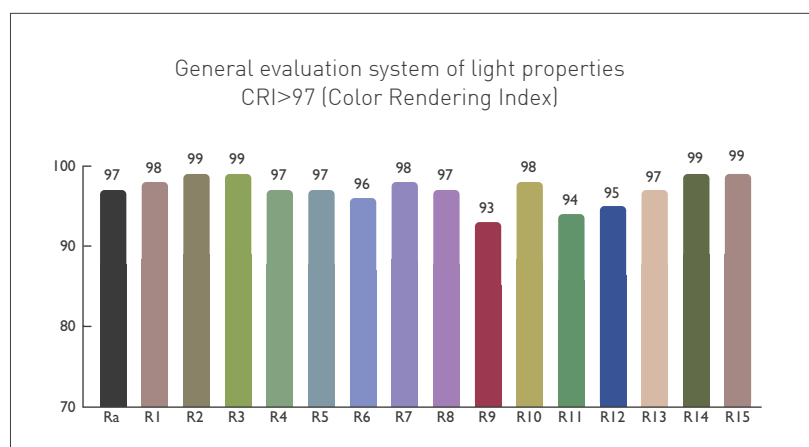
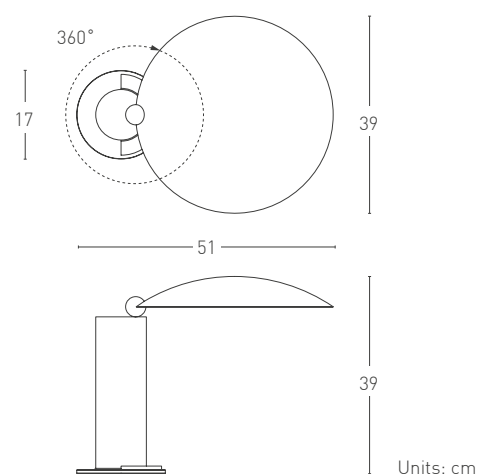

Finishes

- 102 Matte black
- 150 Chrome

Cable

Black fabric

Electronic driver

Included

Light source

LED

LED **luum** 12W 100/240V
730lm 2700K CRI>97

A

Certification



MCP LED

Design Gilles Derain, 1980/2016

Importante esemplare della collezione Classic LCI, la lampada da terra MCP (Merci Chateau Pierre) fu disegnata nel 1980 da Gilles Derain in onore del celebre architetto de "La Maison de Verre", Pierre Chateau. Realizzata in metallo laccato a polveri epossidiche, utilizza sorgenti a LED ed è dotata di regolatore di intensità luminosa. Disponibile nelle finiture nero opaco o alluminio sabbia- to con particolari cromati.

Important piece of LCI Classic collection, MCP (Merci Chateau Pierre) is a floor lamp designed by Gilles Derain in 1980 in honor of the famous architect Pierre Chateau de "La Maison de Verre". It is made of lacquered metal in epoxy powders. Light source LED and dimmer included. Available in matte black or sandblasted aluminum finishes with chrome details.

「MCP (Merci Chateau Pierre)」はLCIのクラシック・コレクションの中でも重要なフロアーランプです、これは1980年にジル・ドレーンが「ラ・メゾン・ド・ヴェール」の設計で有名な建築家ピエール・シャローに捧げる形でデザインしたものです。筐体はスチール製でエポキシ塗装仕上げ。光源には新たにLEDを搭載しました。調光機能内蔵。塗装はブラック半光沢及び梨地アルミカラーにクロムメッキのディテールによるコンビネーション。

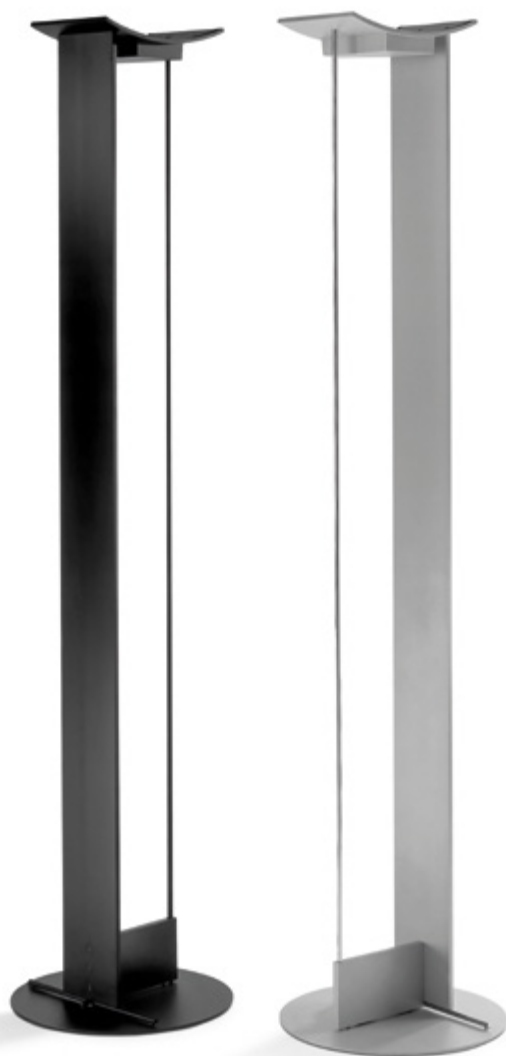
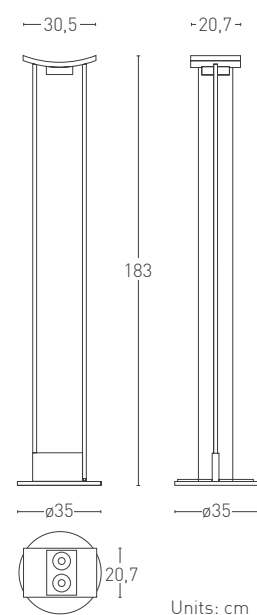

Finishes

- 102 Matte black
- 121 Sandblasted aluminum

Details finishes

- 150 Chrome

Cable

Black

Dimmer

Switch dimmer included

Electronic driver

Dimmable included

Light source

LED

LED 40W 100/120V or 220/240V
3120lm 3000K CRI>90



Certification

CE EAC PS E F Classe I IP20



VICTORY LED

Design Artoff, 1984/2016

Lampada da terra, design Artoff del 1984. Il simbolo "V" come segno di vittoria. La grafica essenziale e l'armoniosa parabola orientabile, evocano il ricordo di un antico trofeo. Dotata di regolatore di intensità luminosa è disponibile nelle finiture: nero opaco, alluminio sabbiato, ottone lucido e cromo.

Floor lamp, designed by Artoff in 1984. The symbol "V" as a sign of victory. The essential graphics and harmonious adjustable reflector recall the memory of an ancient trophy. Dimmer included, it is available in the following finishes: matte black, sandblasted aluminum, polished brass and chrome.

勝利のシンボル"V"『ヴィクトリー』は古代のトロフィーを連想させる非常に簡潔なグラフィックを持ったフロアタイプのランプでアートオフによって1984年にデザインされた作品です。発光部でもある上部の半球体は角度が自由に変わります。調光器付き。塗装は、ブラック半光沢、アルミ・サンドブラスト仕上げ、真鍮・磨き仕上げ、クロム仕上げ。

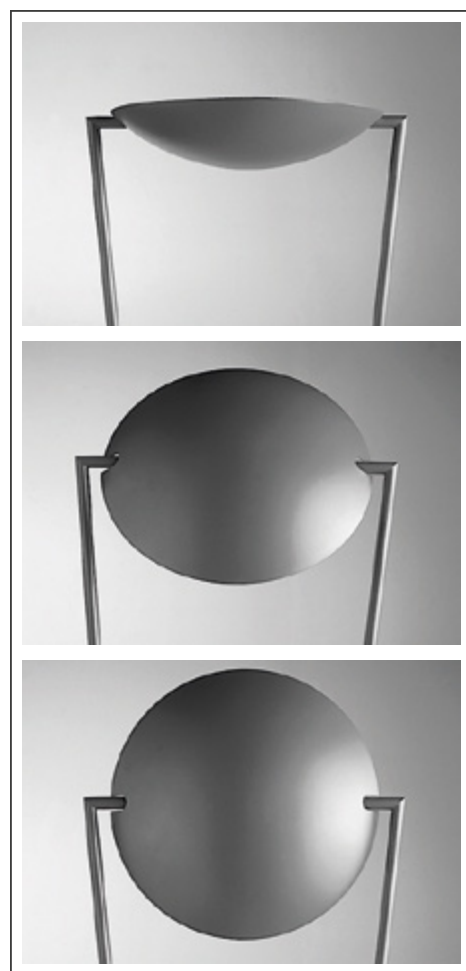
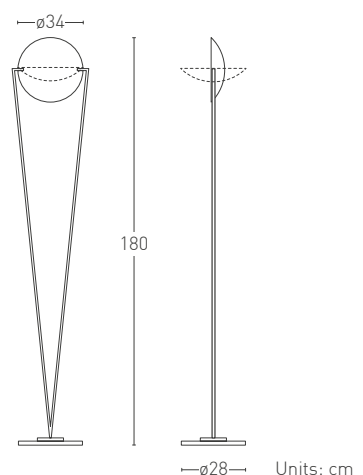

Finishes

- 102 Matte black
- 121 Sandblasted aluminum
- 150 Chrome
- 153 Polished brass

Cable

Black

Electronic driver

Dimmable included

Dimmer

Switch dimmer included

Light source

LED

LED 30W 100/120V or 220/240V
2310lm 3000K CRI>90

A

Certification

CE EAC PS E F Classe I IP20



555 LED / 570 LED

Design Elio Giudici, 1974/2016

555 e 570, storici pezzi della collezione LUMEN CENTER ITALIA, rispettivamente in versione da terra e applique. Il diffusore orientabile è realizzato in metallo, così come il resto della struttura. Forniscono luce indiretta. Disponibili nelle finiture: nero opaco, ottone satinato, cromo, ottone lucido e nichel satinato. Versione da terra dotata di regolatore di intensità luminosa.

555 and 570, historical pieces belonging to the LUMEN CENTER ITALIA collection, respectively floor and wall versions. The adjustable diffuser is made of metal, as the rest of the structure. The lamps give indirect light. Available in the following finishes: matte black, satin brass, chrome, polished brass and satin nickel. The floor version is supplied with a lighting dimmer.

「555」と「570」は、ルーメンセンターのコレクションの中でも歴史的な作品です。この製品は、フロアタイプとウォールタイプで構成されています。拡散光板をはじめ本体は全てメタル製です。ディフューザーの向きが調整が可能です。新たに搭載されたLEDによる間接照明をお届けします。カラーは、ブラック半光沢、真鍮サテン仕上げ、クロム仕上げ、真鍮磨き仕上げ、ニッケル・サテン仕上げが用意されています。フロアタイプには調光器が付属しています。

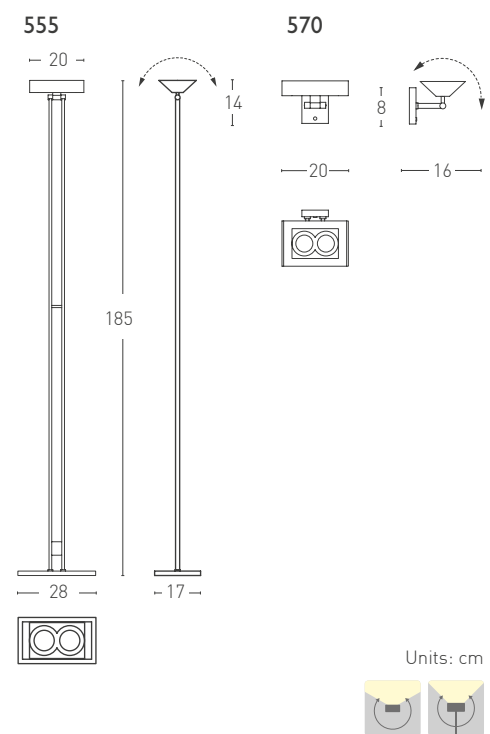

Finishes

- 102 Matte black
- 150 Chrome
- 152 Satin brass
- 153 Polished brass
- 166 Satin nickel

Electronic driver

570 LED Dimmable TRIAC

Dimmer

555 Switch dimmer included

Light source

LED

LED 30W 100/120V or 220/240V
2310lm 3000K CRI>90

A

Certification

CE EAC PS E F Classe I IP20

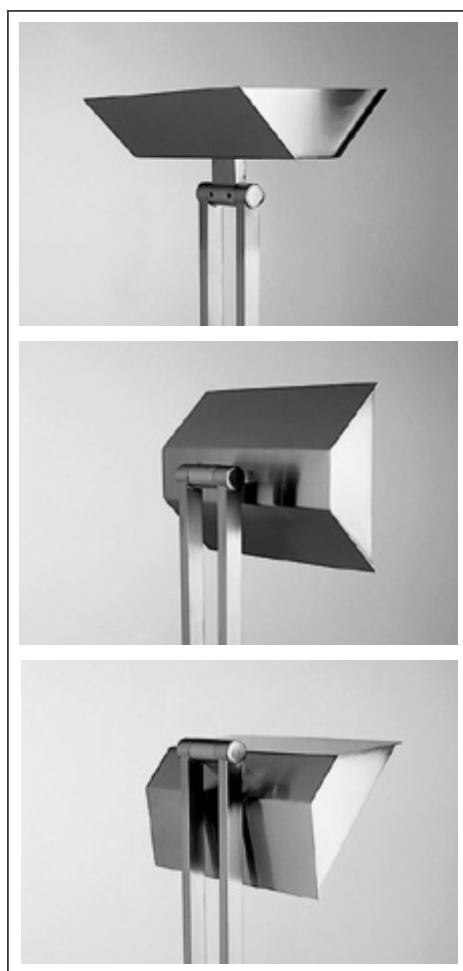

BLUM LED

Design Bernard Brousse, 1997/2016

Disegnata da Bernard Brousse nel 1997 per LUMEN CENTER ITALIA, BLUM è da allora icona della collezione Classic LCI. Realizzata in metallo e caratterizzata da linee molto semplici è disponibile nelle finiture: nero opaco, bianco opaco, grigio sabbia FT.

Designed by Bernard Brousse in 1997 for LUMEN CENTER ITALIA, BLUM since then has been an icon of the Classic LCI collection. Made of metal and characterized by very simple lines, it is available in matte black, matte white, sand grey FT.

1997年ベルナルド・ブルッスによってルーメンセンター・イタリアのためデザインされた作品です。「ブルム」はその当時よりLCIクラシックコレクションの代表的な作品です。メタル製のシンプルなラインによって描き出された作品で、塗装は、ブラック半光沢、ホワイト半光沢、FTサンド・グレー、の3種類が用意されています。

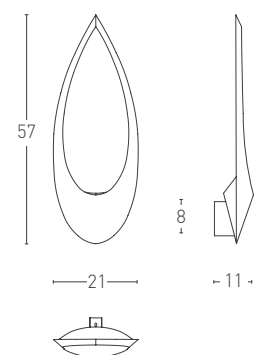

Units: cm



Finishes

- 102 Matte black
- 106 Matte white
- 115R FT Sand Grey

Electronic driver

LED Light Engine Dimmable TRIAC

Light source

LED

LED 15W 100/120V or 220/240V
1155lm 3000K CRI>90

A

Certification

CE EAC PS E F IP20



EAGLE LED

Design Gilles Derain, 1984/2015

Lampada da parete a luce indiretta, disegnata da Gilles Derain nel 1984. Realizzata in metallo laccato a polveri epossidiche. Sorgente LED.

Indirect light wall lamp, designed by Gilles Derain in 1984. Made of lacquered metal in epoxy powder. LED light source.

ウォールタイプ間接照明ランプ。1984年にジル・デレンによってルーメンセンター・イタリアのためにデザインされたランプ。筐体はスチール製でエポキシ樹脂塗装仕上げ。光源はLEDに換装。

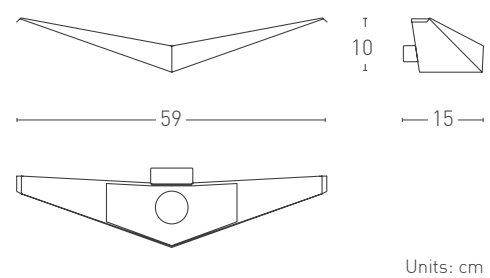
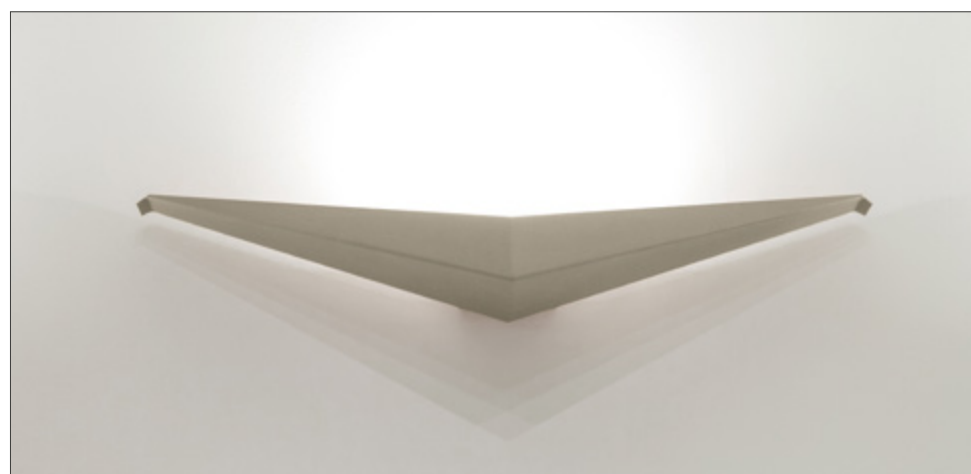

Units: cm

Finishes

- 102 Matte black
- 106 Matte white
- 115R FT Sand grey

Electronic driver

LED dimmable TRIAC

Light source

LED

LED 20W 100/120V or 220/240V
1560lm 3000K CRI>90



Certification

CE EAC PS E F Classe I IP20



TRYLON LED

Design Gilles Derain, 1987

TRYLON, applique disegnata da Gilles Derain nel 1987 realizzata in metallo e disponibile nelle finiture: nero opaco, grigio sabbia FT, cromo e inox satinato.

TRYLON, bracket lamp designed by Gilles Derain in 1987 in metal and available in these finishes: matte black, sand grey FT, chrome and satin inox.

トリロンはルーメンセンター・イタリアのためにジル・デレンがデザインした、ウォールタイプ、ペンダントタイプのクラシックコレクション。この重要なモデルは今、LED版へ進化しました。筐体はメタル製で塗装はブラック半光沢、FTサンド・グレー、クロムメッキ、ステンレス・サテン仕上げが用意されています。

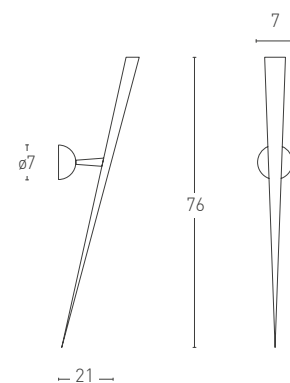

— 21 —

Units: cm



Finishes

TRYLON LED

- 102 Matte black
- 115R FT Sand grey
- 150 Chrome
- 165 Satin inox

Electronic driver

LED Dimmable TRIAC

Light source

LED

TRYLON LED

LED 8W 100/120V or 220/240V

540lm 2700K CRI>90



Certification

CE EAC PSE F IP20 Classe I



TORCHÉRE LED

Design Gilles Derain, 1984/2016

TORCHÉRE, in versione a LED, lampada da parete con attacco a terra. Struttura realizzata in metallo. Disponibile nelle finiture: acciaio inox lucido, acciaio inox satinato, nero opaco e grigio sabbia FT. Regolatore di intensità incluso.

TORCHÉRE LED version, wall lamp with floor socket. Metal structure. Available finishes: polished inox, satin inox, matte black and sand grey FT. Dimmer included.

「トルシエ」は、壁付き電源プラグから給電するウォールタイプのランプです。形はそのままに光源はLEDに換装いたしました。メタル構造でステンレス磨き仕上げ、ステンレス・サテン仕上げ、ブラック半光沢塗装、アルミ・サンドブラスト仕上げが用意されています。調光器付き。

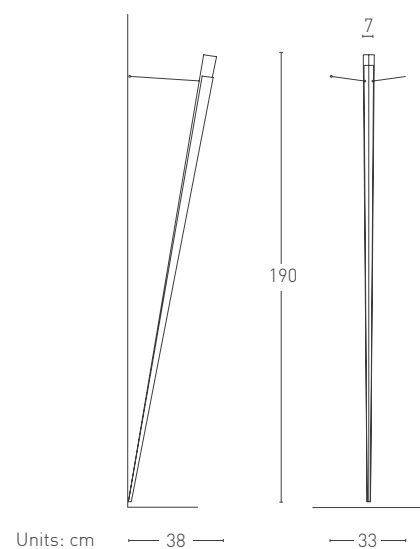

Units: cm — 38 — — 33 —



Finishes

- 102 Matte black
- 115R FT Sand grey
- 155 Polished inox
- 165 Satin inox

Cable

Black

Electronic driver

Dimmable included

Dimmer

Switch dimmer included

Light source

LED

LED 28W 100/240V
2845lm 3000K CRI>90

A

Certification

CE EAC PS E F Classe I IP20

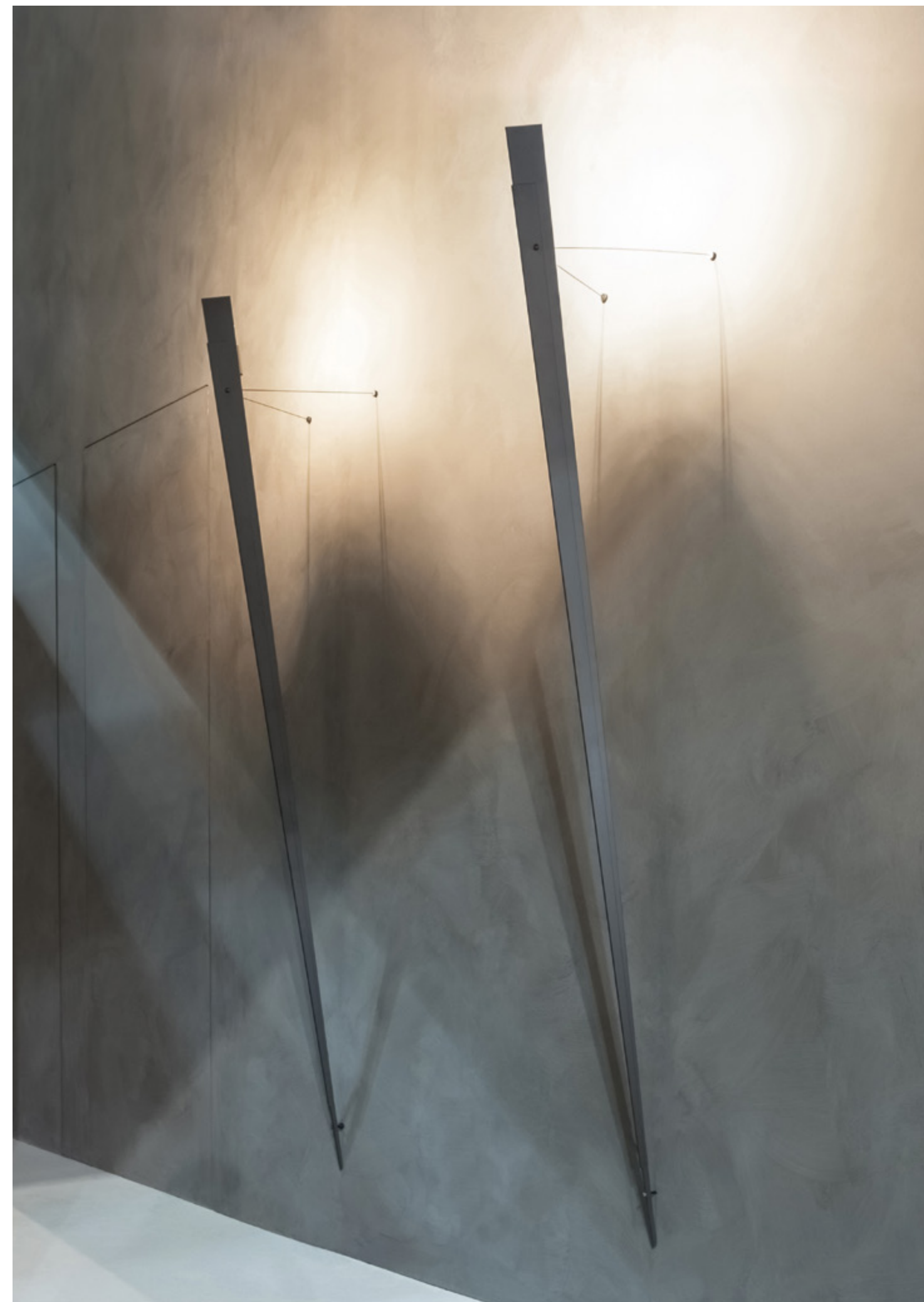

PROJECTS&SYSTEMS

La vocazione di LUMEN CENTER ITALIA per il "su misura" affonda le radici nel tempo ed ha creato negli anni importanti occasioni per crescere, sperimentare e per realizzare grandi progetti a livello internazionale. Attraverso i progetti custom LUMEN CENTER ITALIA ha creato nuovi prodotti, personalizzato ed adattato i propri per creare esperienze di luce che rendessero speciali quei luoghi per cui erano state pensate. La capacità di saper lavorare in maniera "sartoriale" continua a far sì che LUMEN CENTER ITALIA possa realizzare forniture speciali per progetti architettonici e contract, possa realizzare prodotti di illuminazione su disegno del cliente e installazioni artistiche.

"UN GRANDE LABORATORIO CHE PERSEGUE L'ECCELLENZA, IN CUI DESIGNER, ARCHITETTI, INGEGNERI, TECNICI E ARTIGIANI LAVORANO INSIEME"

Augusto Grillo, Presidente LCI

LUMEN CENTER ITALIA's vocation for "custom made" products has deep roots in the past and has created during the years important opportunities to grow, experiment and realize big projects worldwide. Through custom-made projects, LUMEN CENTER ITALIA has created new products, modifying and adapting its standard products to create experiences of light to make special those places they were designed for. The ability to deliver a "custom made" service allows LUMEN CENTER ITALIA to make special editions for architectural and contract suppliers of lighting systems according to the customer's design and for artistic installations.

"A GREAT LABORATORY THAT PURSUES EXCELLENCE, WHERE DESIGNERS, ARCHITECTS, ENGINEERS, TECHNICIANS AND CRAFTSMEN WORK TOGETHER"

Augusto Grillo, President LCI

ルーメンセンター・イタリアの「オーダーメイド」に対する思いは長きに亘って存在しています。数々の重要な機会の度に実験と成長を繰り返し国際レベルのプロジェクトを実現してきました。カスタマイズ化されたプロジェクトを通してルーメンセンター・イタリアは新しい製品を生み出してきました。製品が設置される空間を「光の経験」によって特別なものへするため変更、改良を行ってきました。衣服の様に「テーラー・メイド」することができる実力を備えています。このためルーメンセンター・イタリアは特別な建築・コンラクトプロジェクトの製品提供を可能にし、さらにクライアントのデザインなど芸術的な照明インストールのための製品等も実現可能にしているのです。

「偉大なる工房とは、デザイナー、設計者、技術者や職人などのエンジニアが一丸となって卓越性を追及出来る場です」

アウグスト・グリッロ LCI代表

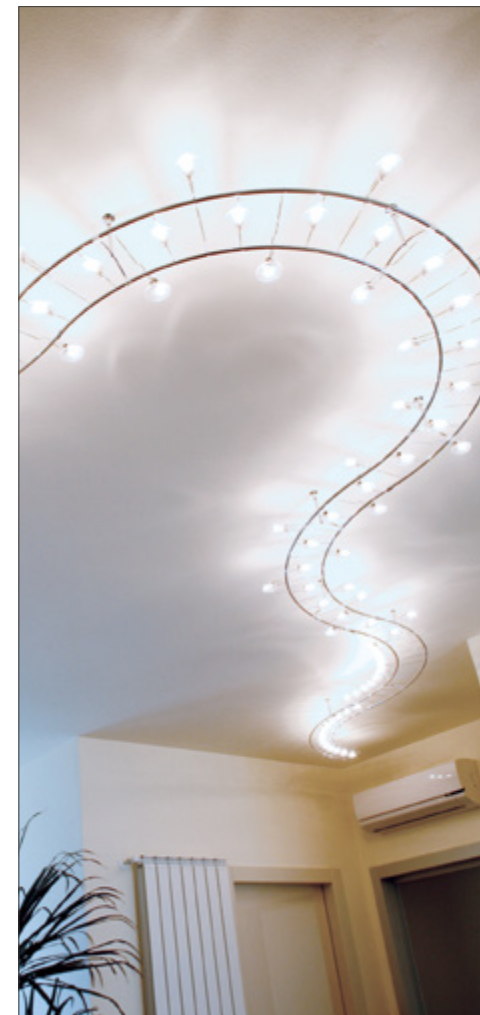
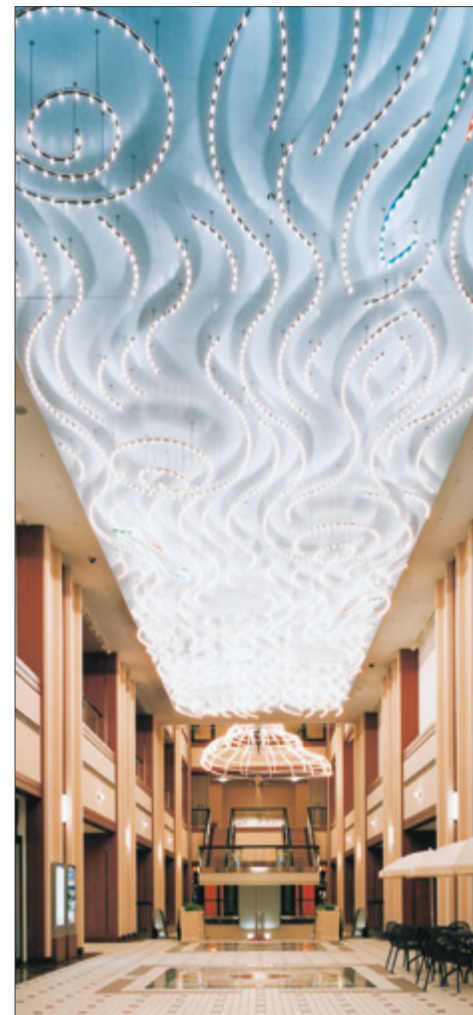

TECHNICAL INFORMATION

Tutti i prodotti LUMEN CENTER ITALIA che rientrano nell'ambito di applicazione della direttiva europea bassa tensione B.T. 73/23 e successiva modifica 93/68, soddisfano ai requisiti richiesti e recano la marcatura CE. Tutte le dimensioni sono espresse in cm. salvo se diversamente indicato nella scheda tecnica. Le istruzioni di montaggio e di manutenzione sono incluse negli imballi, così come i certificati e le condizioni di garanzia. Le indicazioni relative a materiali e finiture riguardano solo le parti principali visibili dei prodotti. Generalmente i prodotti sono forniti senza lampadina salvo se diversamente indicato nel listino prezzi. LUMEN CENTER ITALIA Srl si riserva di apportare qualsiasi modifica tecnica o formale ai prodotti a catalogo senza dovere di preavviso.

Tutti i dati relativi all'efficienza luminosa emessa dai nostri apparecchi, sono da intendersi nominali e riferiti alle specifiche tecniche delle sorgenti luminose (lampade a LED, alogene e fluorescenti) dichiarate dal costruttore. I dati di effettivo consumo ed emissione luminosa, basati sulle caratteristiche elettriche (tensioni e correnti di alimentazione, dimmerabilità ecc.), fisiche ed estetiche degli apparecchi (colore, materiale, tipologia ecc.), verranno fornite al cliente su specifica richiesta.

All LUMEN CENTER ITALIA products that are part of the scope of the European low voltage directive BT 73/23 and consecutive amendment 93/68, meet the necessary requirements and bear the CE labeling. All dimensions are in cm., unless otherwise indicated in the technical sheet. The assembly and maintenance instructions are included in the packages, as well as all certificates and warranty conditions. The indications about the materials and the finishes only refer to the main visible parts of the products. In general, the products are supplied without bulbs, unless otherwise indicated in the price list. LUMEN CENTER ITALIA Srl reserves the right to make any technical or formal modifications to the products contained in the catalogue, without any notice.



















All the data related to the bright efficiency emitted by our devices, are nominal and concerning to the specific technics of our bright sources (LED, halogen and fluorescent lamps) declared by the producer. The data of effective consumption and luminous emission, based on electric characteristics (potential differences and power supplies, dimming etc.) on physic and aesthetic of the devices (colour, material, type etc.) will be provided on customers demand.

ルーメンセンター・イタリアの全ての製品はヨーロッパの低電圧適合指示「B.T.73/23」とその改正事項「93/68」に則って製造されており、その要求仕様を満たした上でCE規格を表示しています。全ての寸法はセンチメートル単位です（テクニカル・シートに特別に記載されている寸法を除く）。取扱説明書、組み立て説明等は商品に同梱されています。証明書ならびに保証書も同様です。製造素材や、塗装に関しては製品の主要部品に関してのみ指定されています。大多数の製品は、電球無しで納品しております。（プライスリストに標記されているものを除く）ルーメンセンター・イタリア Srlはカタログ内にある製品の技術的、デザイン的な変更を前向きなく行うことができる権利を保持しています。

このカタログに記載されている弊社の照明器具で使用している光源の出力データ及び消費電力などはすべて光源製造元の標準データに基づくものです。光源（LED、ハロゲン、蛍光灯、等）の技術仕様は各製造元の情報をご確認ください。照明に搭載されお客様の元に届いている弊社の商品の実際の出力及び消費電力などは、ご使用になる電気の種類（電源の電圧、電流、調光時の状態、等）、照明本体の造形上の特性（色、素材、仕様状態、等）などから、お客様のお手元に届いた商品ごとに標準データと違う場合がございます。あらかじめご了承ください。

Suspension lamp	Dual-emission light	Table lamp	Product conforms to European Community Directive
Diffused light	Indirect light	Diffused light	Product Safety of Electrical Appliance & Materials certification for Japan
Direct light	Diffused indirect light	Dual-emission light	Certification for Russian Federation
Dual-emission light	Indirect light	Direct studio light	
Linear dual-emission light	Diffused light beam	Adjustable light beam studio	IP20 Protected against entry of solid objects larger than 12 mm. No protection against the ingress of water
Indirect light	Adjustable light	Outdoor lamp	IP44 Protected against entry of solid objects larger than 1 mm. Protected against water spray from all direction
Ceiling lamp	Indirect light		IP54 Protected against dust. Protected against water spray from all direction
Diffused light	Floor lamp	Suitable for mounting on normally inflammable surface	
Diffused light beam	Diffused light	Built-in driver	
Diffused light beam	Dual-emission light	Electronic driver	
Diffused indirect light	Indirect light	Classe I Class 1	
Wall lamp	Adjustable light beam	Class 2	
Diffused light	Indirect light	Class 3	

ACCESSORIES AND REPLACEMENTS

	112 114 119 120 130 131 166	Ceiling rose ø8 x 5 cm		ABS P1 Ceiling rose Japan ø9 x 12,5 cm		03 Diffuser Murano Glass HELIOPOLIS HELIOLED HELIO5 18 x 11,6 x 20 cm
	112 114 119 120 130 131 160	Double ceiling rose ø8 x 5 cm		ABS P2 Ceiling rose Japan for steel cable ø9 x 12,5 cm		Diffuser Etched Pyrex CORAL Serie ø2,6 x 9 cm
	112 114 119 120 130 131 166	Small ceiling rose ø7 x 3,5 cm		106 P3 Ceiling rose Japan adapter ø13 x 3,5 cm		Switch dimmer 100/500W 220/240V
	106 150	Ceiling rose 4/8 ø18 x 5 cm		106 P4 Adjustable ceiling rose Japan adapter ø13 x 3,5 cm		Switch dimmer 60/130W 230V
	106 150	Ceiling rose 12/16 ø22 x 5 cm		Picket outdoor TAKË Open air ISASS Open air ø1,5 x 40 cm		
	ABS	Ceiling rose ø12 x 3 cm		Base outdoor TAKË Open air ISASS Open air ø27 x 1,5 cm		
	112 114 119 120 130 131 166	Ceiling rose UL adapter ø12 x 0,6 cm		Cable outdoor 5/10 m		

COLOURS AND FINISHES

EPOXY-POWDERS LAQUERING		102 Matte black		126 Fine textured (FT) Sage green (G)		166 Satin Nickel	LEATHER		CB Black Leather
		103 Fine textured (FT) Black		127 Fine textured (FT) Senape		168 Natural polished Aluminum			CN Natural Leather
		105 Fine textured (FT) White (W)		128 Red Montenapo		171 Polished Aluminum	WOOD		LN Walnut
		106 Matte white		129 Fine textured (FT) Red		172 Natural anodized Aluminum			LR Oak
		112 Glossy black		138 Titanium (T)		173 Dark brown (outdoor use)	GLASSES		LRN Black Oak
		114 Glossy white		139 Cor-ten (N)		174 Black anodized Aluminum			03 Acid opal white
		115E Fine textured (FT) Dust grey	GALVANIC FINISHES		150 Chrome (C)		175 Gold polished Aluminum		04 Acid transparent
		115D Fine textured (FT) Graphite grey			154 Gold		176 Bronzed Brass	OTHER MATERIALS	
		115R Fine textured (FT) Sand grey (S)		157 Black Nickel		177 Copper plated Brass			AL Painted die cast Aluminum
		117 Fine textured (FT) Oxyde	NATURAL METALS		160 Palladium	FOIL FINISHES		130 Gold foil (O)	
	119 Chartreuse green (H)			152 Satin Brass (B)			131 Silver foil (A)		P Satined Pyrex glass
	120 Red (R)		153 Polished Brass		132 Copper foil		PE Polyethylene		
	121 Sandblasted Aluminum	TEXTILE		155 Polished Inox		BC White		PMMA Methacrylate	
	123 Pearl grey			163 Copper		R Red wine		PMMAD Methacrylate Diffuser	
	125 Fine textured (FT) Anthracite grey		165 Satin Inox		W Sage		RA Acrylic resin		

CREDITS

ART DIRECTION

Alessandro Zamperetti

PHOTOS

Barbara Bonomelli
Gianni Comunale
Fernando Guerra / FG+SG
Simona Monfrinotti
Paolo Pandullo
Francesco Radino
Marco Zani
Luigi Cirio

PHOTO EDITING

Marco Zani
Takahiro Aoyama

GRAPHIC DESIGN

Marco Zani

TRANSLATION

Takahiro Aoyama
Cinzia Carnevale
Fabiola Grillo
Simona Secchi

CONTENT DEVELOPMENT

Alessandro Zamperetti
Fabiola Grillo

TECHNICAL DEVELOPMENT

Mario Carcano
Daniele Gianella
Takahiro Aoyama

PRINT

Reda Print Srl

ASSOCIATION

ASSOLOMBARDA
www.assolombarda.it
ASSOLUCE
www.federlegnoarredo.it
ECOLIGHT
www.ecolight.it
LANDBELL
www.landbell.de



LIGHTING SPONSOR



SPECIAL THANKS

LUMEN CENTER ITALIA Srl thanks in particular Casa Linea & Vierwändewerk, Wuppertal (Germany) / Michael and Ulriche Albermann / Casa Taide, Rui Viera Oliveira and Vasco Manuel Fernandez architects - Lahnoso (Portugal) / House of Denmark / De Padova Srl / Il Loft Spa / Casa Cantoni / Casa Cesar Sergio / Casa Pruner / Composit Srl cucine / Novamobili Spa / Ozzio Italia (Pozzoli Group) / Francesca Grillo / Simona Monfrinotti.

Thanks to all the collaborators who have daily supported and worked at the new company relaunch.

Questa pubblicazione sostituisce ed aggiorna i precedenti cataloghi con riferimento ai prodotti elencati in questa pubblicazione.

This publication replaces and updates the previous catalogues with reference to the products contained in this publication.

このカタログに記載されているデータは、これまで出版されたカタログのものから変更されている場合がございます

LUMEN CENTER ITALIA Srl

Via Donatori del Sangue n.37
20010 Santo Stefano Ticino (MI) Italia
tel. +39 02 3654 4811
info@lumencenteritalia.com

ITALY OFFICE

tel. +39 02 3654 4311
italysales@lumencenteritalia.com

EXPORT OFFICE

tel. +39 02 3654 4308
exportsales@lumencenteritalia.com

TOKYO SHOWROOM

1-4-10, Aobadai, Meguro-Ku
153-0042 Tokyo, Japan
tel. +81 3 57 84 31 70
info@lcij.jp

MILAN SHOWROOM

Via Gran San Bernardo n.2
20154 Milano, Italia
tel. +39 02 3180 6511
info@lumencenteritalia.com





LCI
ITALIA

LCI
JAPAN

lumencenteritalia.com
LIGHT CREATIVITY INNOVATION