

NOVELTIES 2023

Lumen center.

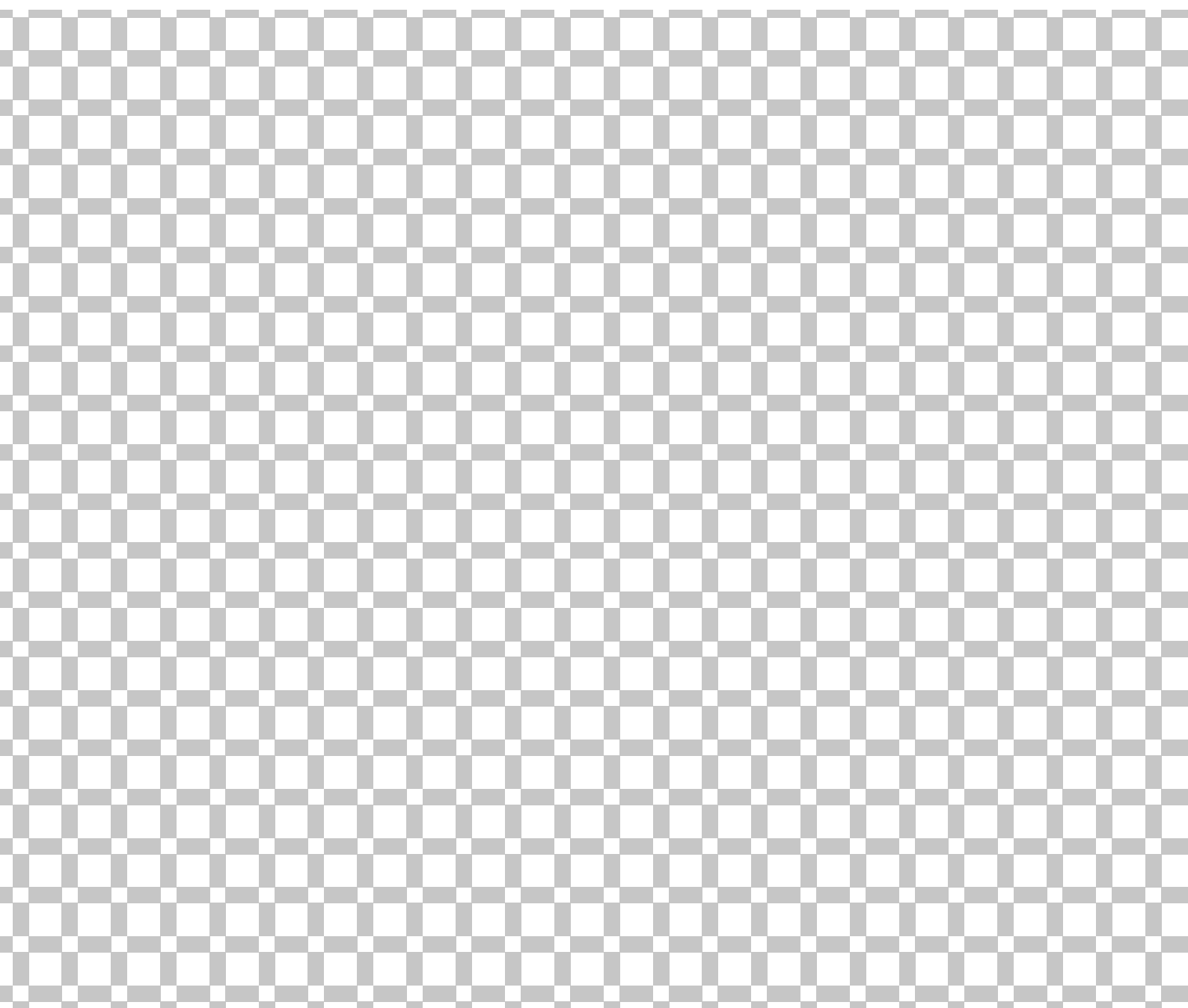

NOVELTIES 2023

Lumen
center.

LA NOSTRA STORIA

—

OUR STORY

L'azienda nasce nel 1976 come LUMEN CENTER nella città provenzale di La-Fare-les-Oliviers, sotto la direzione artistica di Gilles Derain; esponente di rilievo del design contemporaneo francese, Derain fu tra i primi estimatori e studiosi dell'UAM - Union des Artistes Modernes, movimento artistico attivo tra il 1928 e il 1958, che confluì poi nel movimento moderno internazionale.

L'Union des Artistes Modernes annoverava tra i suoi membri e fondatori, designer e architetti tra i quali il celebre Jacques Adnet, che nel 1960 divenne direttore dell'École Nationale Supérieure des Beaux-Arts, posizione che mantenne fino al 1970.

Grazie al suo insegnamento, Gilles Derain impronta il proprio approccio stilistico e progettuale al design dimostrandosi degno erede della lezione del modernismo internazionale, raccogliendo e perpetrando l'importante eredità artistica di Adnet: un esempio tra tutti è la lampada MCP (Merci Chareau Pierre), realizzata da Derain nel 1979 che costituì un enorme successo commerciale, al punto da essere inclusa nella collezione permanente del Museo di Arti Decorative di Montreal.

Nel 1992, LUMEN CENTER viene rilevata da un imprenditore milanese: la consolidata collaborazione con noti designer francesi, tra cui Jean-Michel Wilmotte, e l'alta qualità dei prodotti offerti fanno sì che l'azienda consolidi in poco tempo la propria posizione nel panorama italiano e internazionale dell'illuminazione.

Sul finire degli anni Novanta, l'azienda entra in contatto con il Centro Europeo di Design di Panasonic, VillaTosca Design, realizzando congiuntamente un importante e ambizioso progetto di interior design e illuminazione per il Royal Pines Hotel di Urawa in Giappone. Il progetto viene chiamato "Life River" e ancora oggi rappresenta l'altissimo know-how tecnico-produttivo dell'azienda, nonché la capacità di realizzare con grande flessibilità progetti "tailor-made".

Da allora, innumerevoli sono le iniziative portate avanti dall'azienda

a livello internazionale, come le sperimentazioni sulle sinestesie tra luce, colore e suono, l'utilizzo di sorgenti alternative come gli OLED e gli studi sull'interazione tra luce e metabolismo umano.

LUMEN CENTER è stata inoltre sponsor dell'illuminazione della food court del Padiglione Giappone ad Expo 2015 e illumina le importanti opere di Leonardo Da Vinci, Tiziano, Raffaello, Bruegel e Botticelli presso la Veneranda Pinacoteca Ambrosiana di Milano.

Our company started in 1976 as LUMEN CENTER in the Provencal city of La-Fare-les-Oliviers, under the artistic direction of Gilles Derain. Derain was a prominent exponent of the UAM - Union des Artistes Modernes, an artistic movement active from 1928 to 1958, which later merged into International Modernism.

The Union des Artistes Modernes boasted influential designers, architects, and artists among its members and founders there was the renowned Jacques Adnet, who in 1960 became the director of École Nationale Supérieure des Beaux-Arts, until 1970.

Through his teachings, Gilles Derain imprinted his stylistic and design approach on the organization, proving himself a worthy heir to International Modernism, carrying forward the artistic patrimony that Adnet had established. One example is the MCP lamp (Merci Chareau Pierre), made by Derain in 1979. It was such an enormous commercial success that it was eventually included in the permanent collection of the Montreal Museum of Fine Arts.

In 1992, LUMEN CENTER was acquired by a Milanese entrepreneur. Its well-established collaboration with renowned French designers, including Jean-Michel Wilmotte, and the exceptional quality of its products meant that the company has consolidated its position in the Italian and International stage.

At the end of the 1990s, the company began to collaborate with the European Design Center of Panasonic, VillaTosca Design. Together, they designed and carried out an ambitious interior design and

illumination project for the Royal Pines Hotel in Urawa, Japan. The project was called "Life River". It continues to epitomize the impressive technical-productive know-how of the company and its incredible ability to accomplish "tailor-made" projects.

Since then, LUMEN CENTER has fulfilled countless projects at an international level, experimenting with synesthesia among light, color, and sound; the use of alternative lighting sources like OLED; and the study of the interaction between light and human metabolism.

LUMEN CENTER was also the lighting sponsor of the food court at the Japanese Pavilion at the EXPO 2015 and has illuminated important works from Leonardo Da Vinci, Tiziano, Raffaello, Bruegel, and Botticelli at the Veneranda Pinacoteca Ambrosiana di Milano.

INDEX



44	CHIOCCIOLA FAMILY	LC COLLECTION	
46	CHIOCCIOLA FLOOR		Floor
48	CHIOCCIOLA READING		Floor
48	CHIOCCIOLA TABLE		Table
12	KIRON	LC COLLECTION	Floor
16	LUXSI FAMILY	ESSENTIAL	
18	LUXSI FLOOR		Floor
20	LUXSI READING		Floor
50	ORBIT	LC COLLECTION	Table
38	PLANETS FAMILY	LC COLLECTION	
42	PLANETS 05/08/13		Suspension
34	RING	LC COLLECTION	Suspension
22	SEAFLOWER	ESSENTIAL	Floor
26	SKYLINES FAMILY	ESSENTIAL	
28	SKYLINES S&P		Suspension
30	SKYLINES SUSPENSION		Suspension
32	SKYLINES SYSTEMS		Suspension
06	WASHINGTON (Limited Ed. 40°)	LC COLLECTION	Table
54	ZERO FAMILY	ESSENTIAL	
56	ZERO 11		Floor
58	ZERO FLOOR		Floor
60	ZERO TABLE		Table
62	COLOURS & FINISHES		

40'

LIMITED EDITION (1983 - 2023)





Washington

LIMITED EDITION 40° (1983 - 2023)

SOBRIA ELEGANZA

Disegnata nel 1983 dall'architetto francese Jean-Michel Wilmotte per l'Ambasciata Francese di Washington D.C., Washington celebra alla perfezione la sobria e classica eleganza della LC Collection. Si adatta con versatilità a qualunque contesto, dal soggiorno di casa all'ufficio, emettendo una luce brillante e diffusa.

SUBTLE ELEGANCE

Designed in 1983 by the French architect Jean-Michel Wilmotte for the French embassy in Washington D.C., Washington perfectly celebrates the simple, classic elegance of the LC Collection. Its versatility allows it to adapt to any environment, from the living room to the office, emitting a bright and diffused light.

ÉLÉGANCE SOBRE

Conçue en 1983 par l'architecte français Jean-Michel Wilmotte pour l'ambassade de France à Washington D.C., Washington célèbre à la perfection l'élégance sobre et classique de la LC Collection. Il s'adapte avec polyvalence à tous les contextes, du salon au bureau, émettant une lumière vive et diffuse.

SCHLICHTE ELEGANZ

Die 1983 von dem französischen Architekten Jean-Michel Wilmotte für die französische Botschaft in Washington D.C. entworfene Leuchte Washington verkörpert perfekt die schlichte, klassische Eleganz der LC Collection. Durch ihre Vielseitigkeit passt sie sich jeder Umgebung an, vom Wohnzimmer bis zum Büro, und spendet ein helles und gedämpftes Licht.

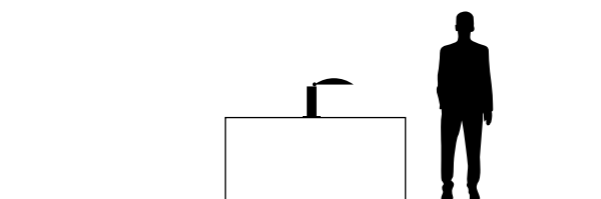

WASHINGTON (Limited Edition 40°)

Design J.M. Wilmotte

- Lampada da tavolo realizzata in metallo, composta dal riflettore orientabile fissato su un corpo cilindrico. Sorgente luminosa LED integrata, dimmer su cavo incluso. Disponibile in due nuove finiture in edizione limitata in occasione del 40° dalla sua ideazione: Nickel Nero Satinato e Rame Spazzolato.

- Table lamp made of metal, composed of adjustable reflector fixed to a cylindrical body. Embedded LED light source, dimmer on cable included. Now available in two new limited edition finishes on the occasion of the 40th anniversary of its creation: Satin Black Nickel and Brushed Copper.

- Lampe à poser en métal, composée d'un réflecteur orientable fixé sur un corps cylindrique. Source de lumière LED intégrée, variateur de lumière sur le câble inclus. Disponible en deux nouvelles finitions en édition limitée à l'occasion du 40e anniversaire de sa conception: Nickel Noir Brossé et Cuivre Brossé.

- Tischleuchte aus Metall, bestehend aus einem verstellbaren Reflektor, der an einem zylindrischen Körper befestigt ist. Eingebaute LED-Lichtquelle mit Dimmer am mitgelieferten Kabel. Anlässlich des 40. Jahrestages ihrer Entstehung ist sie jetzt in zwei neuen, limitierten Ausführungen erhältlich: Satin Black Nickel und Brushed Copper.



FINISHES

- 158 Satin Black Nickel
- 163 Brushed Copper

CABLE

Black fabric

ELECTRONIC POWER

Dimmable Included

LIGHT SOURCE

LED 10W 100/110V or 220/240V
900lm 2700K CRI>90

CERTIFICATION

CE   IP20

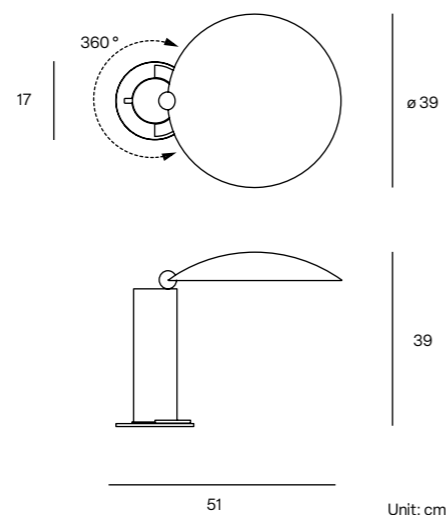



_ Kiron

UN FEDELE CENTAURO DI LUCE

L'antico cavallo da sempre dedito e fedele all'umano spirito, porta su di sé con delicata forza la luce. Far vedere i dettagli, le sfumature, le tinte, le ombre e sullo sfondo le sottili trame della vita. Protendersi e mai sottrarsi al servizio umile e costante di una migliore cura della persona.

A FAITHFUL CENTAUR OF LIGHT

The ancient horse, always dedicated and faithful to the human spirit, carries the light on itself with delicate strength. Show the details, the nuances, the hues, the shadows and the subtle textures of life in the background. Reach out and never withdraw from the humble and constant service of better personal care.

UN CENTAURE DE LUMIÈRE FIDÈLE

Le cheval antique, toujours dévoué et fidèle à l'esprit humain, porte la lumière sur lui avec une force délicate. Montrez les détails, les nuances, les teintes, les ombres et les textures subtiles de la vie en arrière-plan. Tendre la main et ne jamais se retirer du service humble et constant de meilleurs soins personnels.

EIN TREUER ZENTAUR DES LICHTS

Das uralte Pferd, das dem menschlichen Geist stets treu ergeben ist, trägt das Licht mit zarter Kraft auf sich. Zeigt die Details, die Nuancen, die Schattierungen, die Schatten und die subtilen Strukturen des Lebens im Hintergrund. Greifen Sie zu und ziehen Sie sich niemals aus dem bescheidenen und ständigen Dienst einer besseren persönlichen Pflege zurück.

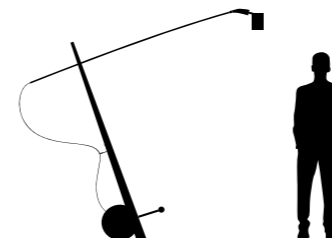

KIRON

Design Ahlux

Kiron è una lampada da terra mobile composta da un'asta in legno pregiato ancorata a due ruote in marmo. Il proiettore di luce sulla sua sommità è orientabile grazie alle tre possibili posizioni dell'asta metallica. I LED di nuova generazione "blue hazard free" con CRI >97 e driver "flicker free" la rendono una lampada ad alto comfort visivo.

Il raccordo tra l'asta e il corpo illuminante è in legno di rovere lavorato a mano, mentre le ruote sono in marmo bianco di Carrara. Disponibile in finitura Nero FT.

Kiron is a movable floor lamp composed of a precious wooden structure anchored to two marble wheels. The LED spot on its top can be adjusted thanks to the three possible positions of the metal rod. The new generation "blue hazard free" LEDs with CRI >97 and driver "flicker free" make it high visual comfort lamp.

The connection between the metal rod and the lighting body is in hand-crafted solid wood, while the wheels are in Carrara marble. Available in black FT finish.

Kiron est un lampadaire mobile composé d'une tige en bois précieux ancrée à deux roues en marbre. Le spot LED sur son dessus est orientable grâce aux trois positions possibles de la tige métallique. Les LED nouvelle génération "blue hazard free" avec CRI >97 et driver "flicker free" en font une lampe à haut confort visuel. Le raccord entre la tige et le spot est en bois de chêne travaillé à la main, tandis que les roues sont en marbre blanc de carrare. Disponible en noir FT.

Kiron ist eine bewegliche Stehleuchte, die aus einem hochwertigen Holzstab besteht, der auf zwei Marmorrädern verankert ist. Der LED-Spot an der Spitze kann, dank der drei möglichen Positionen des Metallstabs, eingestellt werden. Die neue Generation der "Blue Hazard Free"-LEDs mit einem CRI >97 und Driver "Flicker Free" machen sie zu einer Lampe mit hohem Sehkomfort. Die Verbindung zwischen der Stange und dem Leuchtkörper besteht aus handgefertigtem, massivem Eichenholz, während die Räder aus weißem Carrara-Marmor bestehen. Erhältlich in schwarzer FT Lackierung.



FINISHES

103 FT Black + LR Oak

DETAILS

White Carrara Marble

ELECTRONIC DRIVER

Foot dimmer included Dali /Push 01-10

CABLE

Black

LIGHT SOURCE

LED 220/240V
30W 2900lm 2700K CRI>97
BEAM ANGLE: 45°

CERTIFICATION

CE RoHS IP20

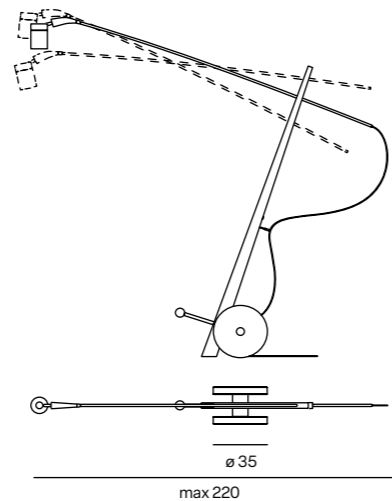

25

206
max

Unit: cm





- Luxsi

FAMILY

UN CORAZZIERE LUMINOSO

Come un corazziere alla guardia, vigile e immoto. Bello, di presenza, alto. Trae dal sole ispirazione per la sua luce armoniosa, equilibrata e naturale.

A BRIGHT CUIRASSIER

Like a cuirassier on guard, watchful and motionless. Handsome, present, tall. From the sun draws inspiration for its harmonious, balanced and natural light.

UN CUIRASSIER LUMINEUX

Comme un cuirassier en garde, vigilant et immobile. Beau, présent, grand. Il s'inspire du soleil pour sa lumière harmonieuse, équilibrée et naturelle.

EIN STRAHLENDER KÜRASSIER

Wie ein Wachmann, immer wachsam und ruhig. Anmutig, präsent, groß. Das harmonische, ausgewogene und natürliche Licht wird von der Sonne inspiriert.

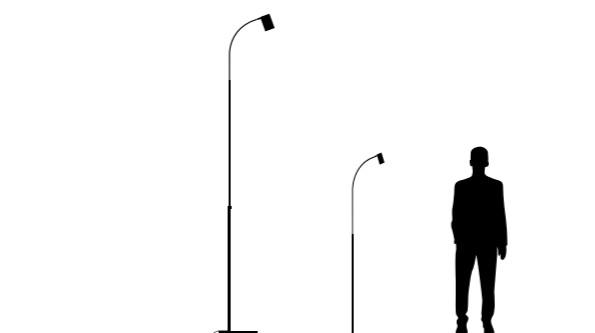

LUXSI FLOOR

Design Ahlux

- Luxsi é una lampada composta da un'asta verticale telescopica, leggermente ricurva sulla sommità che consente di direzionare il corpo illuminante e di posizionarlo a diverse altezze da terra.

I LED di nuova generazione "blue hazard free" con CRI>97 e driver "flicker free" la rendono una lampada ad alto comfort visivo.

Finiture in Bianco e Nero FT con base circolare in marmo bianco di Carrara.

- Luxsi is a lamp composed of a vertical telescopic rod, slightly curved at its top which allows the lighting body to be directed and positioned at different heights from the ground.

The new generation "blue hazard free" LEDs with CRI >97 and driver "flicker free" make it a lamp with high visual comfort.

Finishes in black and white FT with circular base in Carrara white marble.

- Luxsi est une lampe composée d'une tige télescopique verticale, légèrement incurvée à son sommet qui permet d'orienter et de positionner le corps éclairant à différentes hauteurs du sol.

Les LED nouvelle génération "blue hazard free" avec CRI >97 et driver "flicker free" en font une lampe à haut confort visuel.

Finitions en noir et blanc FT avec une base circulaire en marbre blanc de Carrara.

- Luxsi ist eine Leuchte, die aus einer vertikalen, oben leicht gebogenen Teleskopstange besteht, die es ermöglicht, den Leuchtkörper in verschiedenen Höhen über dem Boden auszurichten und zu positionieren.

Die "blue hazard free" LEDs der neuen Generation mit CRI>97 und driver "flicker free" machen sie zu einer Leuchte mit hohem Sehkomfort.

Schwarze und weiße FT Lackierung mit rundem Sockel aus weißem Carrara-Marmor.



FINISHES

103 FT Black + White Carrara Marble
105 FT White + White Carrara Marble

ELECTRONIC DRIVER

Foot dimmer included

CABLE

Black or Transparent

LIGHT SOURCE

LED 220/240V 35W
3300lm 2700K CRI>97
BEAM ANGLE: 45°

CERTIFICATION

CE RoHS IP20

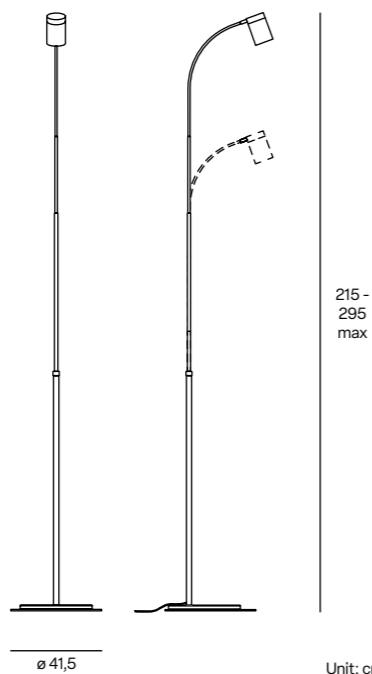

LUXSI READING

Design Ahlux

- Luxsi reading è concepita come lampada da lettura.

Composta da un'asta verticale leggermente ricurva alla sua sommità, permette di direzionare il corpo illuminante consentendo una lettura ottimale da una scrivania o da un divano.

I LED di nuova generazione "blue hazard free" con CRI>97 e driver "flicker free" la rendono una lampada ad alto comfort visivo.

Finiture in Bianco e Nero FT.

- Luxsi reading is conceived as a reading lamp. Composed of a vertical rod slightly curved at the top that allows the lighting body to be directed for optimal reading on a desk or sofa.

The new generation "blue hazard free" LEDs with CRI >97 and driver "flicker free" make it a lamp with high visual comfort.

Black and white FT finishes.

- Luxsi reading est conçue comme une lampe de lecture. Composée d'une tige verticale légèrement incurvée à son sommet en permettant d'orienter le corps d'éclairage, pour une lecture optimale sur un bureau ou un canapé. Les LED nouvelle génération "blue hazard free" avec CRI>97 et driver "flicker free" en font une lampe à haut confort visuel.

Finitions en noir et blanc FT.

- Luxsi reading ist als Leselampe konzipiert. Sie besteht aus einem vertikalen Stab, der an der Spitze leicht gebogen ist und die Ausrichtung des Lichtkörpers ermöglicht, so dass man vom Schreibtisch oder vom Sofa aus optimal lesen kann.

Die "blue hazard free"-LEDs der neuen Generation mit CRI >97 und driver "flicker free" machen sie zu einer Lampe mit hohem Sehkomfort.

Schwarz und weiß FT lackiert.



FINISHES

- 103 FT Black
- 105 FT White

ELECTRONIC DRIVER

Foot dimmer included

CABLE

Black or Transparent

LIGHT SOURCE

LED 220/240V

15W 1400lm

2700K CRI>97

BEAM ANGLE: 43°

CERTIFICATION

CE Luum RoHS IP20

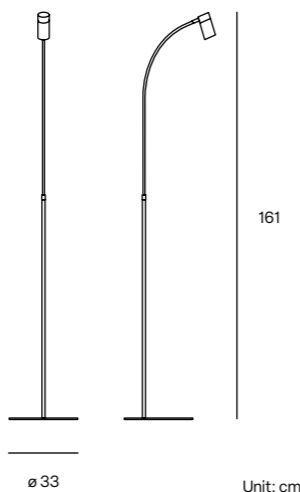

- Seaflower

FIORE RESILIENTE E LUMINOSO

Come un fiore proteso dall'acqua verso l'alto, sottile, resiliente, dona il suo splendore agli oggetti della nostra memoria.

RESILIENT AND BRIGHT FLOWER

Like a flower stretched out from the water upwards, thin, resilient, it gives its splendor to the objects of our memory.

FLEUR RÉSILIENTE ET LUMINEUSE

Comme une fleur tendue de l'eau vers le haut, subtile, résiliente, elle donne sa splendeur aux objets de notre mémoire.

WIDERSTANDSFÄHIGE UND LEUCHTENDE BLUME

Wie eine Blume, die sich aus dem Wasser nach oben streckt, dünn und widerstandsfähig, verleiht sie den Objekten unserer Erinnerung ihren Glanz.

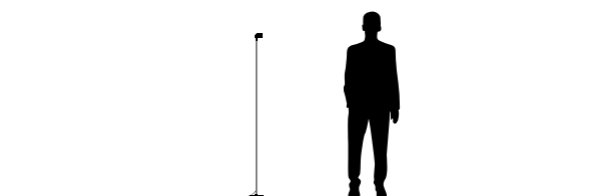

SEAFLOWER

Design Ahlux

- Lampada da terra composta da una esile asta verticale e una basetta di metallo sormontata da marmo Verde Alpi; permette di direzionare il corpo illuminante verso oggetti, sculture, dipinti. Una luce d'accento naturale e preziosa. I LED di nuova generazione "blue hazard free" con CRI>97 e driver "flicker free" la rendono una lampada ad alto comfort visivo.

Finitura in Nero FT.

- Floor lamp composed of a thin vertical rod and a metal base surmounted by Verde Alpi marble; allows the lighting body to be directed towards objects, sculptures, paintings. A natural and precious accent light.

The new generation of LEDs "blue hazard free" with CRI>97 and driver "flicker free" make it a lamp with high visual comfort.

Finish in black FT.

- Lampadaire composée d'une mince tige verticale et une base en métal surmontée de marbre Verde Alpi; permet de diriger le corps éclairant vers des objets, des sculptures, des peintures. Une lumière d'accent naturelle et précieuse.

Les LED de nouvelle génération "blue hazard free" avec CRI >97 et driver "flicker free" en font une lampe à haut confort visuel.

Finition en noir FT.

- Die Stehlampe besteht aus einer schlanken vertikalen Stange mit einem Metallsockel der von Verde Alpi Marmor gekrönt wird. Sie ermöglicht es, den Lichtkörper auf Objekte, Skulpturen und Gemälde zu richten. Ein natürliches und wertvolles Akzentlicht.

Die neue Generation von LEDs "blue hazard free" mit CRI>97 und driver "flicker free" machen sie zu einer Lampe mit hohem Sehkomfort.

Ausführung in schwarzer FT Farbe.



FINISHES

103 FT Black + Verde Alpi Marble

CABLE

Black

ELECTRONIC POWER

Foot dimmer included

LIGHT SOURCE

LED 220/240V

11W 1000lm

2700K CRI>97

BEAM ANGLE : 56°

CERTIFICATION

CE lum RoHS IP20

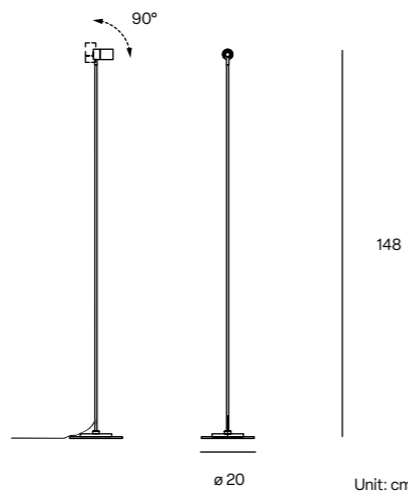



— Skylines

FAMILY

SOTTILI FILI DI LUCI

Come esili fili nel cielo tessono geometrie essenziali. Rimandano alla materia e ai suoi immensi vuoti puntellati di luce. Linee di luce e fili neri, punti di luce e ombre. Poesia nello spazio che si fa chiarore e cura. Skylines è una famiglia di lampade da sospensione e applique composta da sottili tubi metallici intervallati da corpi illuminanti lineari e puntiformi.

SLENDER THREADS OF LIGHTS

Like slender threads in the sky that weave essential geometries. Referring to the matter and its immense voids dotted with light. Lines of light and black threads, points of light and shadows. Poetry in space that becomes light and cure. Skylines is a family of suspension and wall lamps composed of thin metal tubes interspersed with linear and punctiform lighting bodies.

FIN FILS DE LUMIÈRES

Comme de fins fils dans le ciel, que tissent des géométries essentielles. Ils font référence à la matière et à ses immenses vides parsemés de lumière. Lignes de fils clairs et noirs, points de lumière et d'ombres. Poésie dans l'espace qui devient lumière et guérison. Skylines est une famille de suspensions et d'appliques composées de fins tubes métalliques entrecoupés de corps lumineux linéaires et ponctuels.

SCHLANKE FÄDEN AUS LICHT

Wie schlanke Fäden am Himmel weben sie geometrische Formen. Sie verweisen auf die Materie und ihre unermesslichen, von Licht durchzogenen Leerräume. Linien aus Licht und schwarzen Fäden, Lichtpunkte und Schatten. Poesie im Raum, die mit Licht zum Wohlbefinden wird. Skylines ist eine Familie von Hänge- und Wandleuchten, die aus dünnen Metallrohren bestehen, die mit linearen und punktförmigen Lichtkörpern durchsetzt sind.

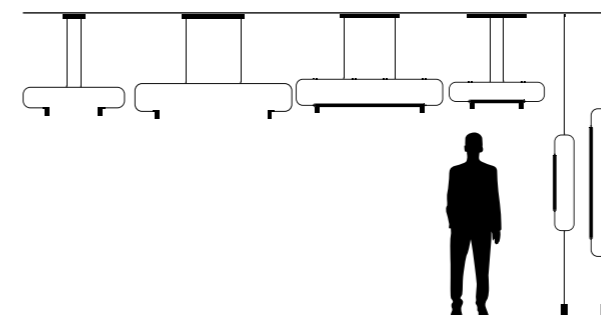

SKYLINES S&P

Design Ahlux

- Lampada da soffitto - pavimento, con ancoraggio a soffitto adattabile a varie altezze e alimentazione da presa elettrica a parete.

Disponibile con vetro Pyrex lineare a forma di fiore o con proiettori orientabili. I proiettori montano LED di nuova generazione "blue hazard free" con CRI >97 e driver "flicker free" la rendono una lampada ad alto comfort visivo.

Finitura in Nero FT e arricchita da dettagli in ottone.

- Ceiling - floor lamp, mounted to the ceiling and adaptable to various heights with plug-in power from electrical wall outlet.

Available with linear Pyrex glass in flower shape or with adjustable projectors. The new generation LED spotlights "blue hazard free" with CRI >97 and driver "flicker free" make it a lamp with high visual comfort.

Black FT finish and enriched with brass details.

- Plafonnier - lampadaire, avec ancrage au plafond adaptable à différentes hauteurs et alimentation par prise électrique murale.

Disponibile avec verre Pyrex linéaire en forme de fleur ou avec des projecteurs orientables. Les projecteurs sont équipés de LED de nouvelle génération "blue hazard free" avec CRI >97 et driver "flicker free" en font une lampe à haut confort visuel.

Finition en Noir FT et enrichie de détails en laiton.

- Decke - Stehleuchte, an der Decke montiert und an verschiedene Höhen mit Steckdosenleiste anpassbar.

Erhältlich mit linearem Pyrex-Glas in Blütenform oder mit verstellbaren Projektoren. Die LED-Strahler der neuen Generation "blue hazard free" mit CRI >97 und Treiber driver "flicker free" machen sie zu einer Leuchte mit hohem Sehkomfort.

Schwarzes FT-Finish und mit Messingdetails verziert.



FINISHES

103 FT Black + 152 Satin Brass

ELECTRONIC POWER

Dimmable included

LIGHT SOURCE

LED 220/240V BEAM ANGLE: 50°

SKYLINES S&P LIN. MIDI 6W 780lm 2700K/3000K CRI>90

SKYLINES S&P LIN. MAXI 12W 1560lm 2700K/3000K CRI>90

SKYLINES S&P SPOT 2x15W 2800lm 2700K/3000K CRI>97

CERTIFICATION

SKYLINES S&P LINEAR   Classe I IP20

SKYLINES S&P SPOT    lum RoHS IP20

SKYLINES S&P MIDI (linear and spot version)

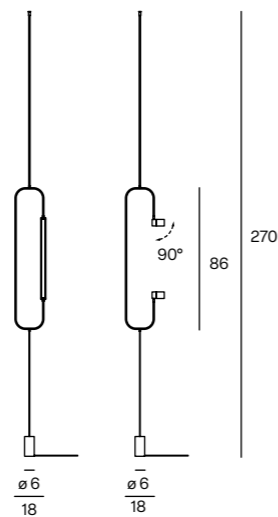

SKYLINES S&P MAXI (linear and spot version)

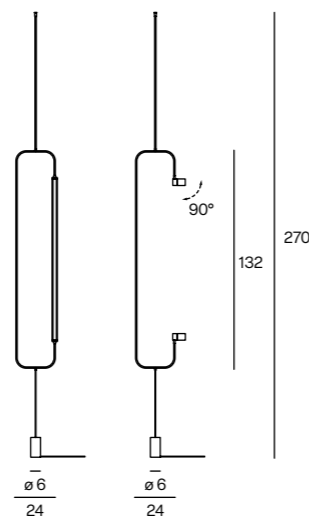

Unit: cm



SKYLINES SUSPENSION

Design Ahlux

- Sospensione disponibile con vetro Pyrex lineare a forma di fiore o con proiettori orientabili. I proiettori montano LED di nuova generazione "blue hazard free" con CRI>97 e driver "flicker free" la rendono una lampada ad alto comfort visivo.

Finitura in Nero FT e arricchita da dettagli in ottone.

- Suspension lamp available with linear Pyrex glass in flower shape or with adjustable projectors. The new generation LED spotlights "blue hazard free" with CRI >97 and driver "flicker free" make it a lamp with high visual comfort. Black FT finish and enriched with brass details.

- Suspension disponible avec verre Pyrex linéaire en forme de fleur ou avec projecteurs orientables. Les projecteurs sont équipés de LED de nouvelle génération "blue hazard free" avec CRI >97 et driver "flicker free" en font une lampe à haut confort visuel.

Finition en Noir FT et enrichie de détails en laiton.

- Hängeleuchte erhältlich mit linearem Pyrex-Glas in Blütenform oder mit verstellbaren Projektoren. Die LED-Strahler der neuen Generation "blue hazard free" mit CRI>97 und driver "flicker free" machen sie zu einer Leuchte mit hohem Sehkomfort.

Schwarzes FT-Finish und mit Messingdetails verziert.



FINISHES

103 FT Black + 152 Satin Brass

ELECTRONIC POWER

Dimmable included

LIGHT SOURCE

LED 220/240V BEAM ANGLE: 50°

SKYLINES SUS. LIN. SMALL 6W 780lm 2700K/3000K CRI>90

SKYLINES SUS. LIN. BIG 12W 1560lm 2700K/3000K CRI>90

SKYLINES SUS. SPOT 2x15W 2800lm 2700K/3000K CRI>97

CERTIFICATION

SKYLINES SUS. LINEAR Classe II IP20

SKYLINES SUS. SPOT lum RoHS IP20

SKYLINES SUSPENSION SMALL
(linear and spot version)

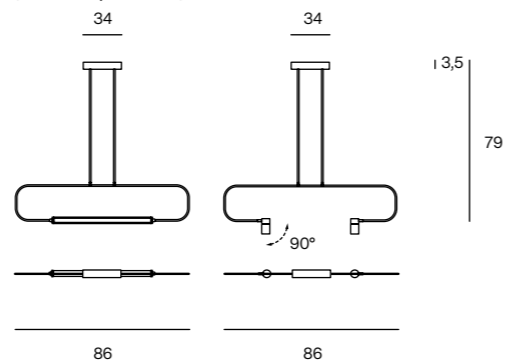

SKYLINES SUSPENSION BIG
(linear and spot version)

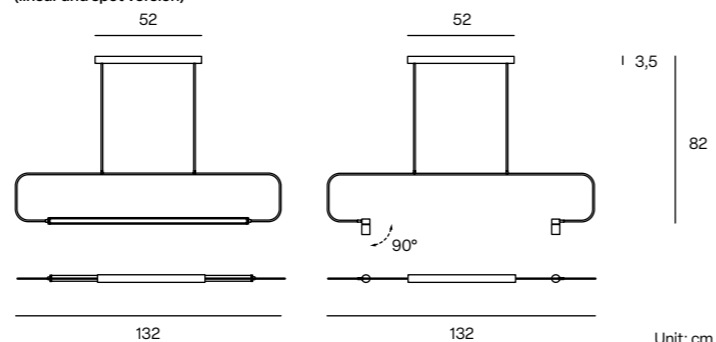

Unit: cm



SKYLINES SYSTEMS

Design Ahlux

- Sistema a sospensione componibile in linee parallele da 2, 3 o 4 moduli.

Disponibile con vetro Pyrex lineare a forma di fiore e con proiettori orientabili. I proiettori montano LED di nuova generazione "blue hazard free" con CRI >97 e driver "flicker free" la rendono una lampada ad alto comfort visivo.

Finitura in Nero FT e arricchita da dettagli in ottone.

- Modular lighting system in parallel lines of 2, 3 or 4 modules.

Available with linear Pyrex glass in flower shape and with adjustable projectors. The new generation LED spotlights "blue hazard free" with CRI >97 and driver "flicker free" make it a lamp with high visual comfort.

Black FT finish and enriched with brass details.

- Système d'éclairage modulaire en lignes parallèles de 2, 3 ou 4 modules.

Disponibile avec verre Pyrex linéaire en forme de fleur et avec projecteurs orientables. Les projecteurs sont équipés de LED de nouvelle génération "blue hazard free" avec CRI >97 et driver "flicker free" en font une lampe à haut confort visuel.

Finition en Noir FT et enrichie de détails en laiton.

- Modulares Aufhängungssystem, in parallelen Linien von 2, 3 oder 4 Modulen.

Erhältlich mit linearem Pyrex-Glas in Blütenform und mit verstellbaren Projektoren. Die LED-Strahler der neuen Generation "blue hazard free" mit CRI >97 und driver "flicker free" machen sie zu einer Leuchte mit hohem Sehkomfort.

Schwarzes FT-Finish und mit Messingdetails verziert.



FINISHES

103 FT Black + 152 Satin Brass

ELECTRONIC POWER

Dimmable included

LIGHT SOURCE

LED 220/240V BEAM ANGLE: 50°

SKYLINES LINEAR MIDL 6W 780lm 2700K/3000K CRI>90

SKYLINES LINEAR MAXI 12W 1560lm 2700K/3000K CRI>90

SKYLINES SPOT 2x15W 2800lm 2700K/3000K CRI>97

CERTIFICATION

SKYLINES LINEAR   Classe I IP20

SKYLINES SPOT    lum RoHS IP20

SKYLINES SYSTEMS 2+1 SMALL

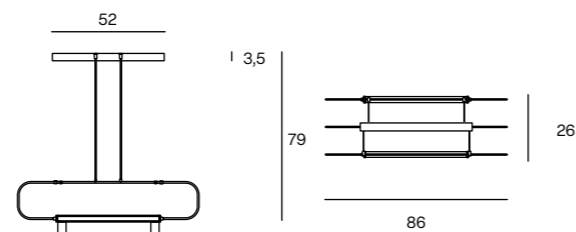

SKYLINES SYSTEMS 2+1 BIG

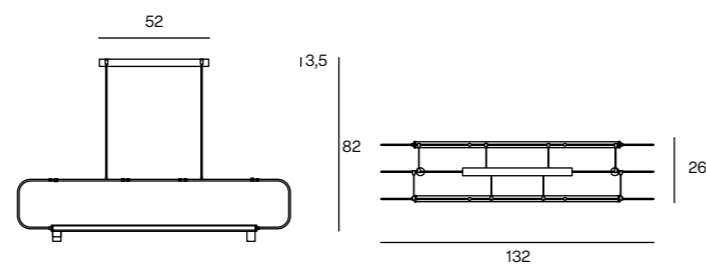

SKYLINES SYSTEMS 2+2

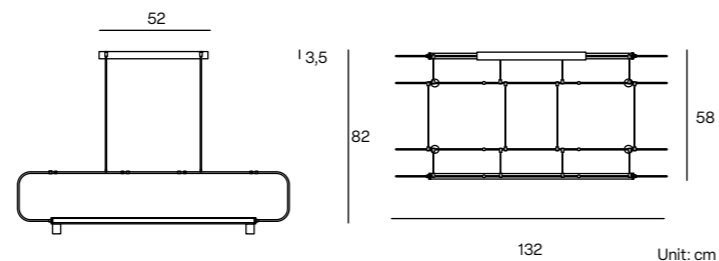

Unit: cm



_ Ring

IL CICLO DELLA VITA

Tre sfere di luce e materia di un lontano umano semblante, confinate nell'immaginario cerchio del cielo e della vita.

THE LIFE CYCLE

Three spheres of light and matter of a semblant human, confined to the imaginary circle of the sky and life.

LE CYCLE DE LA VIE

Trois sphères de lumière et de matière d'un lointain semblant humain, confinées dans le cercle imaginaire du ciel et de la vie.

LEBENSZYKLUS

Drei Sphären aus Licht und Materie eines weit entfernten Menschen, die im imaginären Kreis von Himmel und Leben gefangen sind.

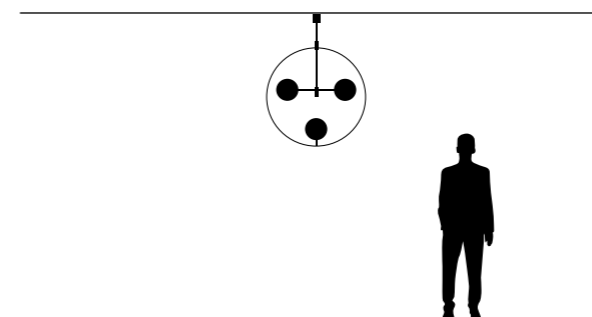

RING

Design Ahlux

- Ring è una lampada da sospensione semplice ed essenziale. Composta da un cerchio e tre sfere in vetro bianco opale lucido al suo interno.

Disponibile in Nero FT e impreziosita da dettagli in bronzo.

- Ring is a simple and essential suspension. It consist of a circle made of brass and three spheres in glossy opal white glass inside.

Available in Black FT and embellished with bronze details.

- Ring est une suspension simple et essentielle. Composée d'un cercle en laiton et de trois sphères en verre blanc opale brillant à l'intérieur.

Disponibile en Noir FT et agrémentée de détails en bronze.

- Ring ist eine einfache und essentielle Hängeleuchte.

Bestehend aus einem Kreis aus Messing und drei Kugeln aus glänzend weißem Opalglas im Inneren.

Erhältlich in Schwarz FT und verziert mit Bronze-Details.



FINISHES

103 FT Black

DETAILS

152 Satin Brass

DIFFUSER

Glossy white glass

LIGHT SOURCE

220/240V E14

100/120V E12

 LED max 3x6W

CERTIFICATION

  Classe I IP20

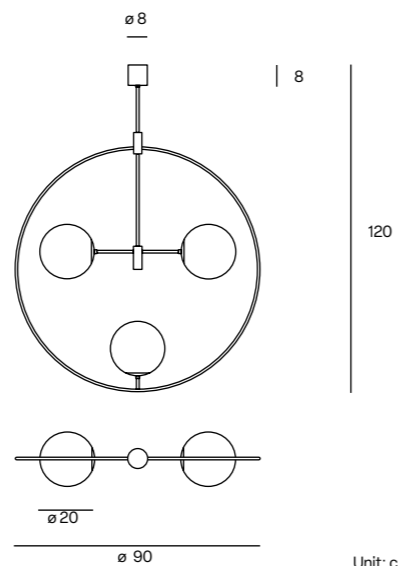

Unit: cm







Planets

FAMILY

IL MAGNETISMO DELLA SFERA

Come un luminoso sistema di corpi celesti, Planets prende ispirazione dal fascino senza tempo e dal magnetismo dei pianeti, caratterizzati dalla perfezione dei profili sferici.

THE MAGNETISM OF THE SPHERICAL

A shining system of celestial bodies, Planets draws inspiration from the timeless fascination of planetary magnetism, characterized by the perfection of spherical contours.

LE MAGNÉTISME DE LA SPHÈRE

Comme un système lumineux de corps célestes, Planets s'inspire du charme intemporel et du magnétisme des planètes, caractérisés par la perfection des profils sphériques.

DER MAGNETISMUS DES SPHÄRISCHEN

Als leuchtendes System von Himmelskörpern lässt sich Planets von der zeitlosen Faszination des planetarischen Magnetismus inspirieren, der sich durch die Perfektion der kugelförmigen Konturen auszeichnet.

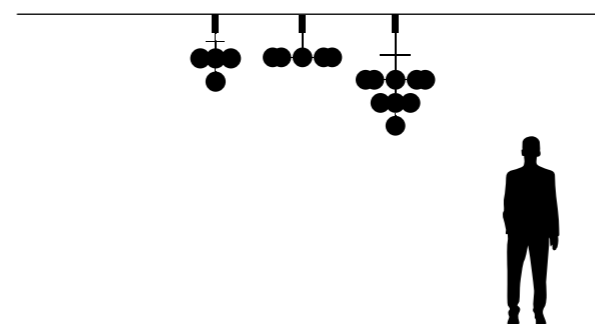

PLANETS 05/08/13

Design Jamo Associates

- Sospensione realizzata in ottone e sfere in vetro bianco opale lucido. Disponibile in 3 differenti versioni a 5, 8 e 13 sfere.

Finiture in nero FT e ottone bronzato, solo per la versione a 13 sfere.

- Suspension made of brass and shades in glossy white opal glass. Available in 3 different versions with 5, 8, 13 shades.

Finishes in black FT and bronzed brass, only for the 13 shades version.

- Suspension en laiton et sphères en verre opale blanc brillant. Disponible en 3 versions différentes à 5, 8 et 13 sphères.

Finitions en noir FT et laiton bronzé, seulement pour la version 13 sphères.

- Hängeleuchte aus Messing und Schirmen aus glänzend weißem Opalglas. Erhältlich in 3 verschiedenen Versionen mit 5, 8 oder 13 Schirmen. Ausführungen in schwarz FT und bronziertem Messing, nur für die Version mit 13 Schirmen.



FINISHES

PLANETS 05/08 ■ 103 FT Black

PLANETS 13 ■ 103 FT Black

■ 176 Bronzed Brass

DIFFUSER

Glossy white glass

LIGHT SOURCE

220/240V E14

100/120V E12

 LED max 13x6W

CERTIFICATION

  Classe I IP20

PLANETS 05

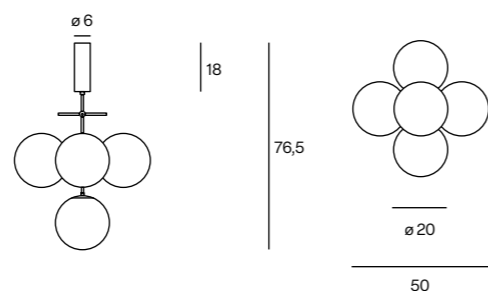

PLANETS 08

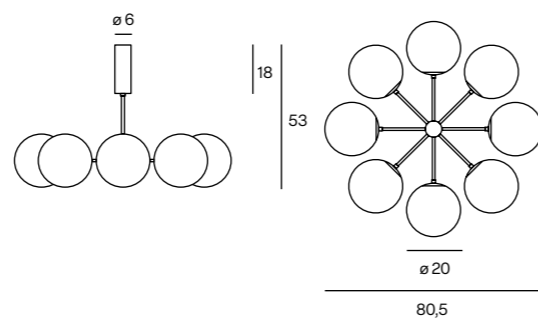

PLANETS 13

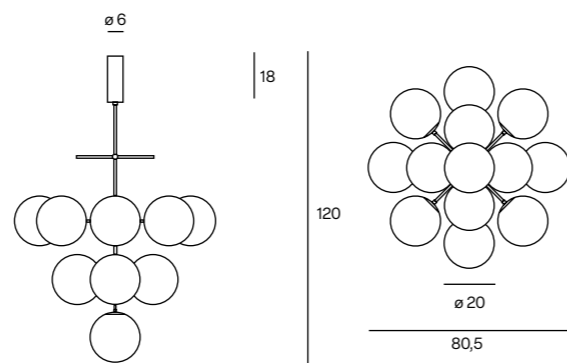

Unit: cm





- Chiocciola

FAMILY

EQUILIBRIO NATURALE

La famiglia Chiocciola si presenta come una collezione di oggetti silenziosi, dove protagonista è la luce, diretta e orientabile. Oggetti architettonici dove la leggerezza incontra la solidità di materiali nobili come il legno e il marmo in una sintesi di stasi e movimento.

NATURAL BALANCE

Chiocciola family resembles a collection of silent objects where protagonist is light, direct and adjustable. Architectural objects where lightness meets the solidity of noble materials such as wood and marble in a synthesis of stasis and movement.

ÉQUILIBRE NATUREL

La famille Chiocciola se présente comme une collection d'objets silencieux, où le protagoniste est la lumière, directe et orientable. Des objets architecturaux où la légèreté rencontre la solidité de matériaux nobles comme le bois et le marbre dans une synthèse de stase et de mouvement.

NATÜRLICHES BALANCE

Die Chiocciola Familie präsentiert sich als eine Sammlung von stillen Objekten, in der der Protagonist das Licht ist, direkt und einstellbar. Architektonische Objekte, bei denen die Leichtigkeit die Festigkeit edler Materialien, wie Holz und Marmor, in einer Synthese aus Stasis und Bewegung trifft.

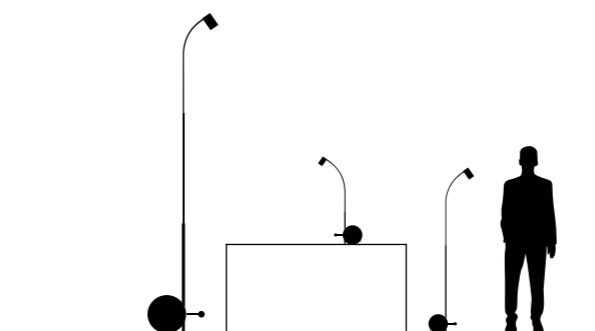

CHIOCCIOLA FLOOR

Design Ahlux

- Apparecchio di illuminazione da terra con asta telescopica che consente di essere utilizzato in differenti contesti. Lo spot LED sulla sommità dell'asta è orientabile in verticale grazie a uno snodo integrato. I LED di nuova generazione "blue hazard free" con CRI >97 e driver "flicker free" la rendono una lampada ad alto comfort visivo.

La struttura principale è disponibile in Nero o Bianco FT. Base circolare in marmo bianco di Carrara e legno noce Canaletto.

- Floor luminaire with telescopic rod that allows it to be used in different contexts. The LED spot on the top of the rod can be adjusted vertically thanks to an integrated joint. New generation "blue hazard free" LED with CRI >97 and driver "flicker free" makes it a lamp and a high visual comfort.

Main structure available in black or white FT finishes. Circular base in white Carrara marble and Canaletto walnut.

- Lampadaire avec tige télescopique qui permet d'être utilisé dans différents contextes.

Le spot LED au sommet de la tige est orientable verticalement grâce à une articulation intégrée. Les LED nouvelle génération "blue hazard free" avec CRI >97 et driver "flicker free" en font une lampe à haut confort visuel.

La structure principale est disponible en noir ou blanc FT. Base circulaire en marbre blanc de Carrare et bois noyer Canaletto.

- Stehlampe mit Teleskopstange, die es ermöglicht, sie in verschiedenen Kontexten zu verwenden. Der Led-Spot auf der Spitze der Stange kann dank eines integrierten Gelenks vertikal verstellt werden. Die neue Generation „blue hazard free“ LEDs mit CRI >97 und driver „flicker free“ machen sie zu einer Leuchte mit hohem Sehkomfort. Die Hauptstruktur ist mit schwarzen oder weißen FT Verzierungen verfügbar. Kreisförmiger Grund aus weißen Carrara-Marmor und Canaletto-Nussbaum.



FINISHES

■ 103 FT Black + □ White Carrara
□ 105 FT White + □ White Carrara

ELECTRONIC DRIVER

Foot dimmer included

CABLE

Black or Transparent

LIGHT SOURCE

LED 220/240V 30W
2900lm 2700K CRI>97
BEAM ANGLE: 45°

CERTIFICATION

CE lum RoHS IP20

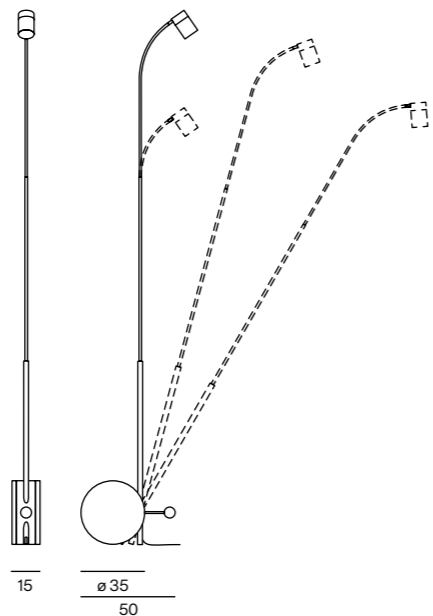

210 -
290
max

Unit: cm



CHIOCCIOLA READING / TABLE

Design Ahlux

- A completamento della collezione, Chiocciola Reading e Table sono stati concepiti per spazi dedicati alla lettura, al lavoro e alla concentrazione.

Gli spot LED sono orientabili in verticale grazie a uno snodo integrato. I LED di nuova generazione "blue hazard free" con CRI >97 e driver "flicker free" la rendono una lampada ad alto comfort visivo.

Il corpo principale è disponibile in Nero o Bianco FT.

Base circolare in nero o bianco e legno di noce Canaletto.

- Completing the collection, Chiocciola Reading and Table have been designed for spaces dedicated to reading, work and concentration.

The LED spot can be adjusted vertically thanks to an integrated joint. New generation "blue hazard free" LED with CRI >97 and driver "flicker free" makes it a lamp and a high visual comfort.

Main structure available in black or white FT finishes.

Circular base in black or white finishes and Canaletto walnut.

- Pour compléter la collection, Chiocciola lecture et à poser ont été conçues pour des espaces dédiés à la lecture, au travail et à la concentration.

Les spots LED sont orientables verticalement grâce à une articulation intégrée. Les LED nouvelle génération "blue hazard free" avec CRI >97 et driver "flicker free" en font une lampe à haut confort visuel.

Le corps principal est disponible en noir ou blanc FT.

Base circulaire en noir ou blanc et bois de noyer Canaletto.

- Um das Angebot an mobilen Geräten zu vervollständigen, wurden Chiocciola Reading und Table für Lese-, Arbeits- und Konzentrationsbereiche konzipiert. Die LED-Spots kann dank eines integrierten Gelenks vertikal verstellt werden. Die neue Generation „blue hazard free“ LEDs mit CRI >97 und „driver flicker free“ machen sie zu einer Leuchte mit hohem Sehkomfort. Die Hauptstruktur ist mit schwarzen oder weißen Verzierungen verfügbar. Kreisförmiger Grund aus weiß oder schwarz und Canaletto-Nussbaum.



FINISHES

103 FT Black + LN Walnut
105 FT White + LN Walnut

ELECTRONIC DRIVER

CHIOCCIOLA READING Foot dimmer included
CHIOCCIOLA TABLE Push dimmer included

CABLE

Black or Transparent

LIGHT SOURCE

LED 220/240V

CHIOCCIOLA READING 15W 1400lm BEAM ANGLE: 50°
CHIOCCIOLA TABLE 11W 1000lm BEAM ANGLE: 56°
2700K CRI>97

CERTIFICATION

CE Luum RoHS IP20

CHIOCCIOLA TABLE

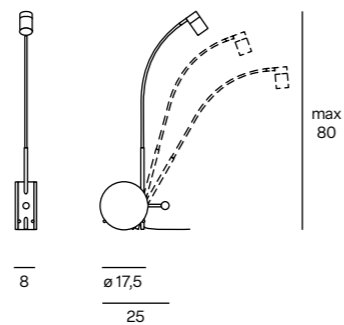

CHIOCCIOLA READING

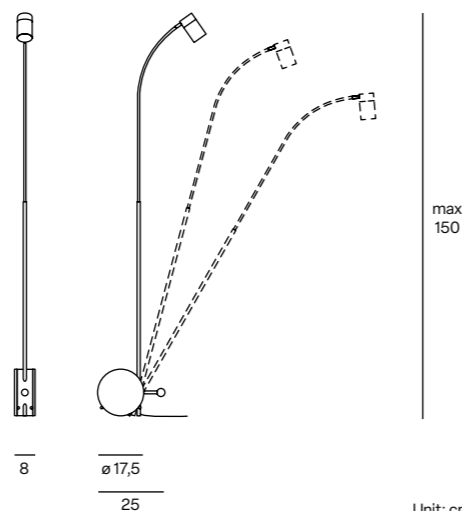

Unit: cm





Orbit

II (RE EDITION 2022)

EQUILIBRIO SENZA TEMPO DI LUCE E DESIGN

La linea, la sfera e la semisfera sono gli elementi geometrici principali che caratterizzano il design iconico e flessuoso di Orbit. La sua morfologia ricorda la traiettoria descritta nello spazio dal moto di un pianeta intorno al sole e la sua presenza invita a interagire con la luce in una relazione emozionale.

TIMELESS BALANCE OF LIGHT AND DESIGN

The line, the sphere and the half-sphere are the main geometric elements featured in the iconic and lithe design of Orbit. Its morphology recalls the trajectory carved by the movement of a planet around the sun and its presence invites to interact with light in an emotional relationship.

ÉQUILIBRE INTEMPOREL DE LUMIÈRE ET DE DESIGN

La ligne, la sphère et la demi-sphère sont les principaux éléments géométriques qui caractérisent le design iconique et souple d'Orbit. Sa morphologie rappelle la trajectoire décrite dans l'espace par le mouvement d'une planète autour du soleil et sa présence invite à interagir avec la lumière dans une relation émotionnelle.

ZEITLOSE BALANCE AUS LICHT UND DESIGN

Die Linie, die Kugel und die Halbkugel sind die geometrischen Hauptelemente, wodurch sich das ikonische und geschmeidige Design von Orbit kennzeichnet. Seine Morphologie erinnert an die Flugbahn der bewegenden Planeten um die Sonne und seine Präsenz lädt zur Interaktion mit dem Licht in einer emotionalen Beziehung ein.

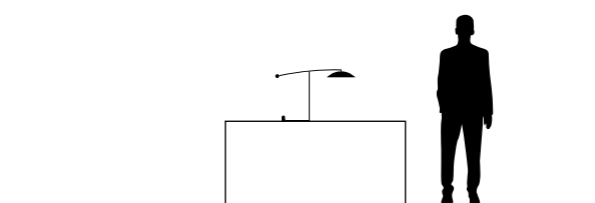

ORBIT

Design K. Gray

- Lampada da tavolo dimmerabile. Diffusore e struttura orizzontale mobile attorno all' asta verticale di 360°. La connessione elettrica tra il driver a spina e il corpo lampada é di tipo magnetico.

Completamente realizzata in ottone e disponibile nelle finiture nero opaco, cromo lucido e oro satinato.

- Dimmable table lamp. Horizontal shade structure swiveling 360°. Magnetic cable connection between the structure and plug-in electronic driver.

Completely made of brass and finishes available in matte black, chrome and satin gold.

- Lampe à poser dimmable. Diffuseur et structure horizontale mouvante autour de la tige verticale de 360°. La connexion électrique entre le driver plug-in et le corps de lampe est de type magnétique.

Entièrement réalisé en laiton et disponible dans les finitions noir mat, chrome brillant et or brossé.

- Dimmbare Tischlampe. Diffuser und horizontale Struktur, die um 360° schwenkbar ist. Magnetische Kabelverbindung zwischen der Struktur und dem elektronischen Plugin- Treiber. Komplett aus Messing und mit Verzierungen verfügbar in mattschwarz, Chrom und Satin-Gold.



FINISHES

- 102 Matte black
- 150 Chrome
- 151 Satin Gold

CABLE

Black

ELECTRONIC DRIVER

Push dimmer included

LIGHT SOURCE

LED PCB 100/120V or 220/240V 7W
910lm 2700K CRI>90

CERTIFICATION

CE IP20

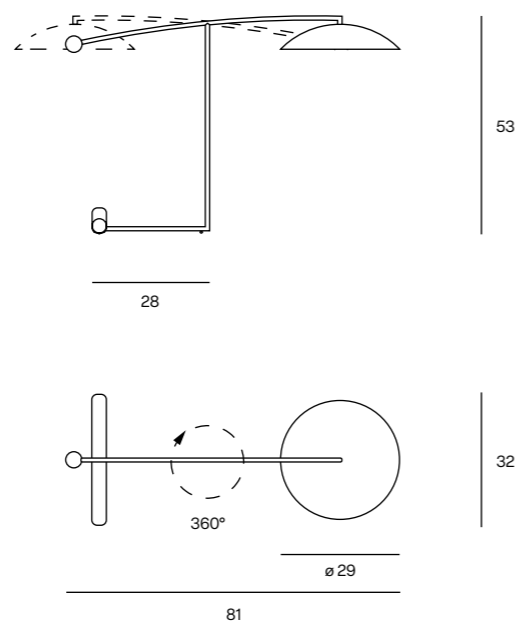

Unit: cm





- Zero

FAMILY

INIZIO SENZA FINE, FORMA PERFETTA.

Il simbolo matematico per eccellenza che racchiude in sé l'infinito è la chiave di ispirazione della famiglia Zero, disegnata da Paolo Cappello.

Le nuove proposte rappresentano un esercizio di ricerca di come la luce può integrarsi in spazi e ambienti mutevoli e dinamici.

ENDLESS BEGINNING, PERFECT SHAPE.

The mathematical symbol par excellence that embodies infinity is the inspirational key of the Zero family, designed by Paolo Cappello. The novelties proposed represents a research on how light can be integrated in dynamic spaces and environments.

DÉBUT INFINI, FORME PARFAITE.

Le symbole mathématique par excellence qui renferme l'infini est la clé de l'inspiration de la famille Zero, conçue par Paolo Cappello. Les nouveaux produits représentent un exercice de recherche sur la façon dont la lumière peut s'intégrer dans des espaces et des environnements changeants et dynamiques.

ANFANG OHNE ENDE, PERFEKTE FORM.

Das mathematische Symbol schlechthin, das die Unendlichkeit verkörpert, ist der inspirierende Schlüssel der Zero-Familie, entworfen von Paolo Cappello. Die neuen Vorschläge stellen eine Forschung darüber dar, wie das Licht in dynamische Räume und Umfelder integriert werden kann.

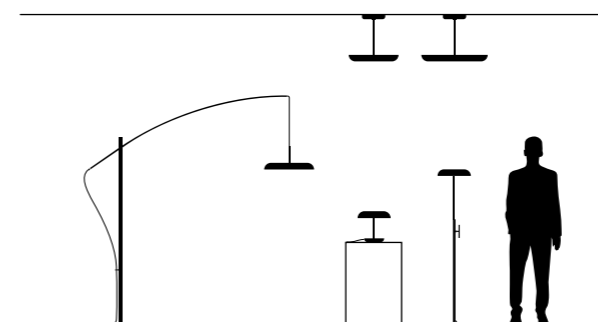

ZERO 11

Design P. Cappello

Lampada da terra con diffusore in alluminio tornito in lastra nella dimensione di diametro 45 cm, verniciata a polveri epossidiche, è regolabile in altezza grazie allo scorrimento del cavo all'interno dell'asta ricurva.

L'asta orizzontale permette di regolare l'estensione della lampada fino a un massimo di 2 m.

Disponibile in diverse finiture, con dettagli in alluminio anodizzato oro. Sorgente luminosa LED SMD integrata a luce diretta. In dotazione standard driver con controllo della dimmerazione diretta, tramite dimmer a pedale.

Floor lamp made of turned aluminum and coated epoxy powders, with shade size of 45 cm and adjustable in height thanks to the sliding cable inside of the curved rod. The upper structure, being movable, allows to extend the lamp up to a maximum of 2mt.

Available in different finishes, with gold anodized aluminium details. Integrated SMD LED light source with direct light. Standard pedal dimming with built-in driver.

Lampadaire avec diffuseur en aluminium tourné en feuille dans la dimension de diamètre 45 cm, peinte en poudre époxy, est réglable en hauteur grâce au glissement du câble à l'intérieur de la tige incurvée. La tige horizontale permet de régler l'extension de la lampe jusqu'à un maximum de 2 m. Disponible en différentes finitions, avec des détails en aluminium anodisé or. Source lumineuse LED SMD intégrée à lumière directe. Le driver standard est fourni avec un contrôle de gradation directe, par un dimmer à pédale.

Stehlampe mit Diffuser aus gedrehtem Aluminium und lackiert mit Epoxidharz-Pulverlacke, mit 45 cm Durchmesser und höhenverstellbar dank dem verschiebbaren Kabel in der gebogenen Stange. Die horizontale Stange ermöglicht die Dehnung bis auf maximal 2 m. Verfügbar mit verschiedenen Verzierungen, mit Details aus goldeloxiertem Aluminium. Integrierte SMD LED-Lichtquelle mit direktem Lichtaustritt und TRIAC dimmbare, elektronische Stromversorgung. Dimming erfolgt durch einen Standard-Fußschalter mit eingebautem Treiber.



FINISHES

- 103 FT Black
- 105 FT White

DETAILS

- 178 Gold Anodized

DIFFUSER

PMMA metacrylate

CABLE

Black or Transparent

ELECTRONIC DRIVER

Foot dimmer included

LIGHT SOURCE

LED SMD 220/240V 28W
2020lm 2700K
2100lm 3000K
CRI>90

CERTIFICATION

CE Classe I IP20

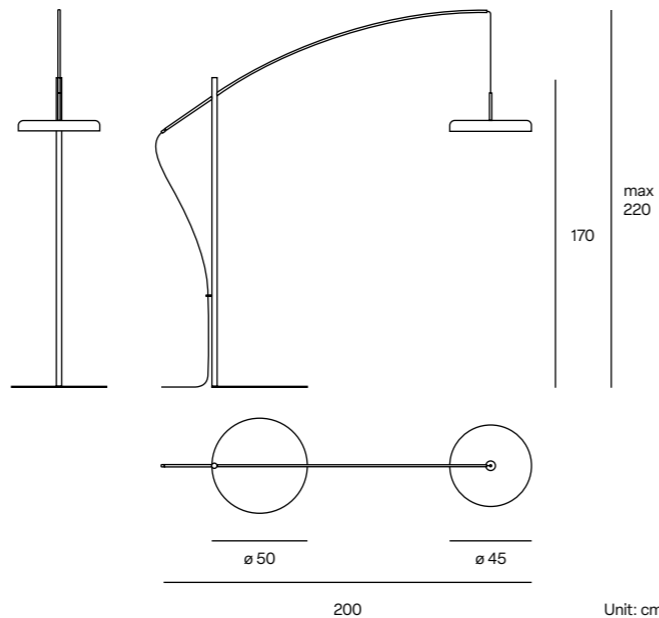

Unit: cm



ZERO FLOOR

Design P. Cappello

Lampada da terra regolabile in altezza, grazie ad un'asta telescopica che può essere bloccata con una chiavetta disegnata per garantire il fissaggio.

Il diffusore in alluminio tornito in lastra nella dimensione di diametro 30 cm è verniciato a polveri epossidiche.

Disponibile in diverse finiture. Sorgente luminosa LED SMD integrata a luce diretta. In dotazione standard driver con controllo della dimmerazione diretta, tramite dimmer a pedale.

Standing floor lamp adjustable in height, thanks to a telescopic rod that can be fixed.

Made of turned aluminum and coated in epoxy powders, with shade size of 30 cm.

Available in different finishes. Integrated SMD LED light source with direct light. Standard pedal dimming with built-in driver.

Lampadaire réglable en hauteur, grâce à une tige télescopique qui peut être verrouillée avec une clé dessinée pour assurer la fixation.

Le diffuseur en aluminium tourné en plaque d'un diamètre de 30 cm est peint avec des poudres époxy.

Disponibile en différentes finitions. Source lumineuse LED SMD intégrée à lumière directe. Le driver standard est fourni avec un contrôle de gradation directe, par un dimmer à pédale.

Höhenverstellbare Stehlampe dank einer Teleskopstange, die fixiert werden kann. Aus gedrehtem Aluminium und lackiert mit Epoxidharz-Pulverlacke, mit 30 cm Durchmesser. Verfügbar in verschiedenen Verzierungen. Integrierte SMD LED-Lichtquelle mit direktem Lichtaustritt. Dimming erfolgt durch einen Standard-Fußschalter mit eingebautem Treiber.



FINISHES

- 103 FT Black
- 105 FT White

DETAILS

- 178 Gold Anodized

DIFFUSER

PMMA metacrylate

CABLE

Black or Transparent

ELECTRONIC DRIVER

Foot dimmer included

LIGHT SOURCE

LED SMD 220/240V 15W
1150lm 2700K
1200lm 3000K
CRI>90

CERTIFICATION

CE Classe IIP20

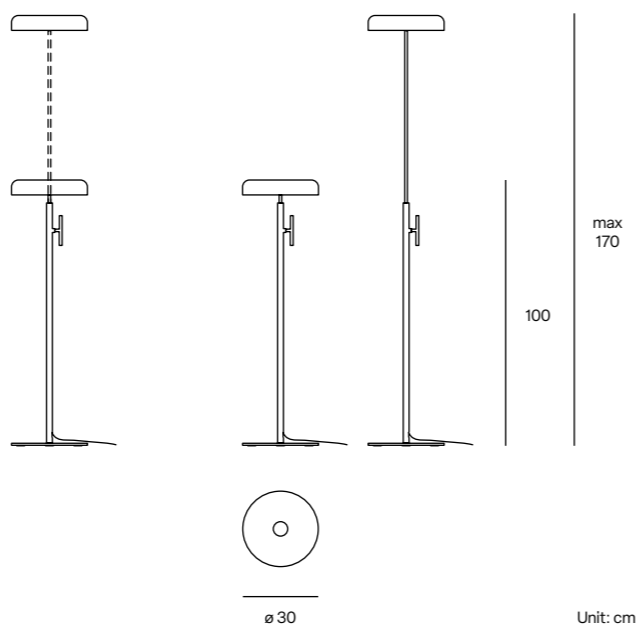

ZERO TABLE

Design P. Cappello

Lampada da tavolo dal design accattivante che riassume in toto l'idea progettuale della forma circolare rassicurante e iconica.

Da utilizzare su étagère, madie, scrivanie in ufficio o zone di lavoro domestiche.

In alluminio tornito in lastra nella dimensione di diametro 30 cm, verniciata a polveri epossidiche.

Disponibile in diverse finiture. Sorgente luminosa LED SMD integrata a luce diretta.

Table lamp with an attractive design that matches at best the idea of the reassuring and iconic circular shape.

To be used on étagère, cupboards, desks in the office or domestic work areas.

Made of turned aluminum and coated in epoxy powders, with shade size of 30 cm.

Available in different finishes. Integrated SMD LED light source with direct light.

Lampe à poser au design attrayant qui résume en entier l'idée de conception de la forme circulaire rassurante et iconique.

À utiliser sur des étagères, des armoires, des bureaux ou des zones de travail domestiques.

En aluminium tourné en plaque d'un diamètre de 30 cm, peint avec des poudres époxy

Disponibile en différentes finitions. Source lumineuse LED SMD intégrée à lumière directe.

Tischlampe mit attraktivem Design, die perfekt der Idee der beruhigenden und ikonischen runden Form entspricht. Zu verwenden auf Etagère, Schränke, Schreibtische im Büro oder in häuslichen Arbeitsbereichen. Aus gedrehtem Aluminium und lackiert mit Epoxidharz-Pulverlacke, mit 30 cm Durchmesser. Verfügbar in verschiedenen Verzierungen. Integrierte SMD LED-Lichtquelle mit direktem Lichtaustritt.



FINISHES

- 103 FT Black
- 105 FT White
- 138 FT Brown Red
- 140 Gres Dove-grey

DETAILS

- 178 Gold Anodized

DIFFUSER

PMMA metacrylate

CABLE

Transparent

ELECTRONIC DRIVER

Push button dimmer included

LIGHT SOURCE

LED SMD 220/240V 15W
1150lm 2700K
1200lm 3000K
CRI>90

CERTIFICATION

CE Classe IIP20

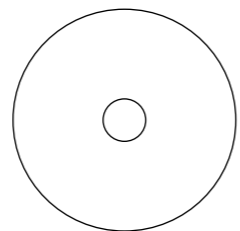
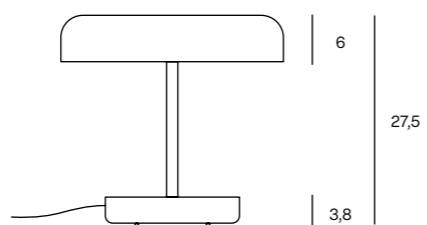

ø 30

Unit: cm















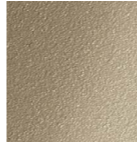
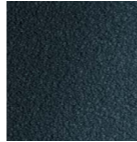

COLOURS & FINISHES

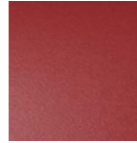
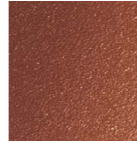
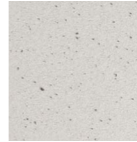

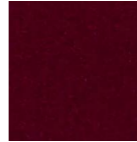

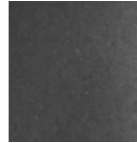
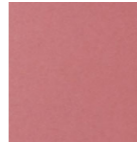







VERNICIATURA

PAINTING

	102 Matte Black
	103 Fine textured (FT) Black
	105 Fine textured (FT) White
	106 Matte White
	112 Glossy black
	114 Glossy White
	115D Fine textured (FT) Graphite grey
	115R Fine textured (FT) Sand Grey
	119 Chartreuse green
	120 Red
	125 Fine textured (FT) Anthracite grey
	126 Fine textured (FT) Sage Green
	127 Fine textured (FT) Senape

	129 Fine textured (FT) Red
	138 Fine textured (FT) Red Brown
	139 Cor-Ten
	140 Gres Dove-grey
	173 Dark brown (outdoor use)
	F14 Flocky Bordeaux
	F15 Flocky Petrol
	F16 Flocky Dark-grey
	F23 Flocky Pink
	F36 Flocky Beige
	130 Gold Foil
	131 Silver Foil
	158 Satin Black Nickel

	163 Brushed Copper
	172 Natural anodized aluminum
	174 Black anodized aluminum
	178 Gold Anodized
GALVANICA	
GALVANIC	
	150 Chrome
	151 Satin Gold
	152 Satin Brass
	153 Polished Brass
	154 Pure Gold
	157 Black Nickel
	176 Bronzed Brass



TESSUTO

TEXTILE

	BC White
	R Red wine
	W Sage

VETRO

GLASS

	03 Acid opal white
	04 Acid transparent

LEGNO

WOOD

	LN Walnut
	LR Oak

MARMO

MARBLE

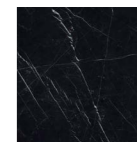
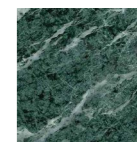
	B White Carrara
	N Black Marquinia
	V Verde Alpi

All LUMEN CENTER products that are part of the scope of the European low voltage directive BT 73/23 and consecutive amendment 93/68, meet the necessary requirements and bear the CE labeling. All dimensions are in cm unless otherwise indicated in the technical sheet. The assembly and maintenance instructions are included in the packages, as well as all certificates and warranty conditions. The indications about the materials and the finishes only refer to the main visible parts of the products. In general, the products are supplied without bulbs, unless otherwise indicated in the price list. LUMEN CENTER Italia Srl reserves the right to make any technical or formal modifications to the products contained in the catalogue, without any notice. All the data related to the bright efficiency emitted by our devices, are nominal and concerning to the specific technics of our bright sources (LED, halogen and fluorescent lamps) declared by the producer. The data of effective consumption and luminous emission, based on electric characteristics (potential differences and power supplies, dimming etc.) on physic and aesthetic of the devices (colour, material, type etc.) will be provided on customers demand.

Tutti i prodotti LUMEN CENTER che rientrano nell'ambito di applicazione della direttiva europea bassa tensione B.T. 73/23 e successiva modifica 93/68, soddisfano ai requisiti richiesti e recano la marcatura CE. Tutte le dimensioni sono espresse in cm salvo se diversamente indicato nella scheda tecnica. Le istruzioni di montaggio e di manutenzione sono incluse negli imballi, così come i certificati e le condizioni di garanzia. Le indicazioni relative a materiali e finiture riguardano solo le parti principali visibili dei prodotti. Generalmente i prodotti sono forniti senza lampadina salvo se diversamente indicato nel listino prezzi. LUMEN CENTER Italia Srl si riserva di apportare qualsiasi modifica tecnica o formale ai prodotti a catalogo senza dovere di preavviso. Tutti i dati relativi all'efficienza luminosa emessa dai nostri apparecchi, sono da intendersi nominali e riferiti alle specifiche tecniche delle sorgenti luminose (lampade a LED, alogene e fluorescenti) dichiarate dal costruttore. I dati di effettivo consumo ed emissione luminosa, basati sulle caratteristiche elettriche (tensioni e correnti di alimentazione, dimmerabilità ecc.), fisiche ed estetiche degli apparecchi (colore, materiale, tipologia ecc.), verranno fornite al cliente su specifica richiesta.

**Lumen
center.**

Lumen Center Italia Srl
SEDE OPERATIVA
Via Donatori del Sangue, 37
20010 Santo Stefano Ticino (MI), Italy
Ph. (+39) 02 36544311
info@lumencenteritalia.com

ITALY OFFICE
tel. +39 02 3654 4311
italysales@lumencenteritalia.com

EXPORT OFFICE
tel. +39 02 3654 4310
exportsales@lumencenteritalia.com

CONTENT DEVELOPMENT
Erika Nicole Visintin

GRAPHIC DESIGN
Erika Nicole Visintin

3D IMAGES & PHOTO EDITING
Zonelab

COPYWRITING
Augusto Grillo
Erika Nicole Visintin

TRANSLATION
EN_ Fabiola Alice Grillo
FR_ Erika Nicole Visintin
DE_ Sandra Cerutti

PRINT
Grafiche 2000 srl

April 2023

