

CLOUD HIGH BACK <sup>BY</sup> LUCA NICHETTO  
ISOLE <sup>BY</sup> NENDO & NICHETTO  
CATCH BAR STOOL <sup>BY</sup> JAIME HAYON



# THE COLLECTION

(2017)

**&tradition<sup>®</sup>**



# THE COLLECTION

(2017)

**&tradition<sup>®</sup>**

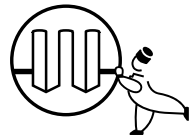

---

**We strive for timeless designs born  
out of tradition and revolution.  
We honour old masters,  
who were avant-garde in their time  
and welcome new designers  
creating icons of tomorrow.**

PALETTE DESK JH9, CATCH CHAIR JH2,  
WORKING TITLE DESK LAMP HK1





FLY SOFA SC12, FLY TABLE SC5,  
FLOWERPOT VP3



CLOUD SOFA LN3.2, FORMAKAMI JH3 & JH5, PALETTE JH8,  
CATCH LOUNGE JH14, THE MOOR RUG AP6



Luca Nichetto is an Italian designer who operates from his offices in Italy and Sweden. A graduate from the University Institute of Architecture of Venice (IUAV), he opened his own firm Nichetto & Partners in 2006. Nichetto loves to collaborate with designers from around the globe to craft compelling concepts using natural materials and colours. Merging classic with contemporary - with personality.

## CLOUD HIGH BACK

WITH LUCA NICHETTO'S CLOUD SOFA THE AIM WAS TO PRODUCE THE ESSENCE OF COMFORT. THE NEW VERSIONS, CLOUD HIGH BACK LN6 & LN7, ARE NO EXCEPTION - ACCENTUATING THE FEELING OF FLOATING ON YOUR OWN CLOUD.

BY LUCA NICHETTO

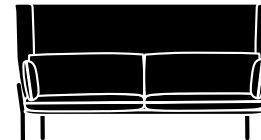
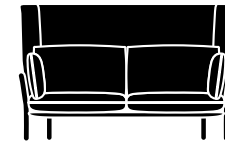

It is easy to guess the inspiration behind the Cloud Series. Come closer, have a seat and do not be surprised if you feel like you are floating on air. Designed to be spacious and expansive, Italian-born, Swedish-based designer Luca Nichetto wanted to minimise anything voluminous and accentuate the look and feel of lightness. Seen in this new version of Cloud Sofas with a high back.

"Everyone is drawn to the idea of floating on a cloud," says &tradition CEO Martin Kornbek Hansen. "It is the quintessence of comfort. With the high-back version of Cloud Sofas, Nichetto augments the impression of lightness both visually and experientially. At the same time, he expresses the concept of cosy, which is very close to our hearts. In Danish, we call it hygge."

The secret to Cloud's truly hygge sensation involves feather and foam-filled seat cushions resting on an upholstered solid wood base. Slim steel legs keep the base "afloat", with a special coating in black, chrome or bronzed. The cushions along the back are secured in place with a curved shell that extends quite high above your back, constructed from foam-wrapped plywood covered in the same textile to match the cushions.

"When you are floating on a cloud, you are in your own world," explains Nichetto. "With the high-back versions of the sofa, you feel comfy, free and able to focus. Even the acoustics are more intimate. It is like having your own cloud up in the sky. It is a concept – but it is real. A private space you can share with others."

Consider this your invitation to sit in them. Lie down in them. Have a chat with someone in them. And enjoy that uncanny feeling of being utterly enveloped by them.





FLY SOFA SC12, FLY TABLE SC5,  
FLOWERPOT VP3



CLOUD HIGH BACK LN6, FORMAKAMI JH3





ISOLE NN1, THE MOOR RUG AP8, PALETTE JH7,  
TRUE COLOURS LP4 & LP6,

Oki Sato is a Canadian-born Japanese designer with a Master's Degree in architecture from the Waseda University in Tokyo. In 2002 Sato established his design studio Nendo, which means moulding clay, to reflect his flexible approach to reinventing design. The recipient of numerous awards and accolades, Sato takes his inspiration from parenthetical moments in life to bring beauty and simplicity to a cross-pollination of projects that endeavour to make the ordinary extraordinary.

Luca Nichetto is an Italian designer who operates from his offices in Italy and Sweden. A graduate from the University Institute of Architecture of Venice (IUAV), he opened his own firm Nichetto & Partners in 2006. Nichetto loves to collaborate with designers from around the globe to craft compelling concepts using natural materials and colours. Merging classic with contemporary - with personality.

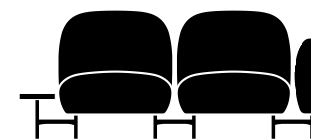

## ISOLE

&TRADITION IS PLEASED TO ANNOUNCE THE  
LAUNCH OF NENDO & LUCA NICHETTO'S ISOLE NN1 –  
A MODULAR SOFA WHERE CREATIVE  
CONNECTIVITY BRIDGES TIME AND SPACE.

BY NENDO & LUCA NICHETTO

Two designers from different cultures virtually co-created the modular Isole Sofa via a process of exchanging ideas inspired by Japanese poetry. Oki Sato, founder of the Tokyo-based design studio Nendo, and Luca Nichetto, Italian founder of Stockholm-based Nichetto Studio, instantly felt a kindred creative spirit when initially they met over coffee in Tokyo. Defying the geographical distance between them, Nendo and Nichetto subsequently found a new way to collaborate long distance applying the concept behind Tanka, a traditional genre of Japanese poetry, where one person starts the poem and the other person completes it.

"I was thinking of soft, organic forms like pebbles, stones, drops of water, islands," explains Sato. "But I had no idea how they could connect and become furniture. I did a sketch, took a photo with my iPhone and sent it to Luca." "I am from Venice so I know about islands," says Nichetto. "When I saw the first sketch I realized that these islands needed bridges. So I designed the armature as a bridge to connect the islands into individual seats, and each seat into a modular sofa."

The outcome is Isole, Italian for islands. A truly unique sofa concept enabling a variety of combinations and configurations, including versions with and without an "island" arm cushion. Variations include a discrete round, square or rectangular side table that integrates beautifully with the overall aesthetics. The impression? Soft, inviting and endearing.

"Typically, modular sofas tend to be square, stiff and driven by functionality first," says &tradition CEO Martin Kornbek Hansen. "With the Isole Sofa, Nendo & Nichetto have brought beauty, balance and a sense of poetry to a design that feels cosy and friendly even before you sit in it. What's more, the concept itself is very much aligned with our Danish appreciation of nature, alluding to pebbles and the ocean. In a simple, organic shape with subtle details and superb craftsmanship."

"It's all about emotion," adds Sato. "That's what links people with objects, people with space, people with people." As Nichetto sees it, "I hope people will also somehow feel the magic we had when designing the sofa. It captures a sense of individuality and yet it facilitates individuals connecting with each other."

Enjoy this new approach to sitting and socialising, reflecting the collaborative process behind the sofa's own conception. Where creative connectivity was the bridge between time and space and the designers themselves.



ISOLE NN1



ISOLE NN1, PALETTE TABLE JH7





CATCH BAR STOOL JH16



Jaime Hayon is a Spanish artist / designer with offices in Italy, Spain and Japan. Known for his deep respect for artisan skills, finely-crafted details and a passion for play, Hayon is considered one of the most influential creators of our time, blurring the lines between art, decoration and design. A prolific designer always seeking new horizons, his scope of work extends from furniture, lighting and home accessories to hotel and retail interiors, as well as ceramics, shoes and timepieces.

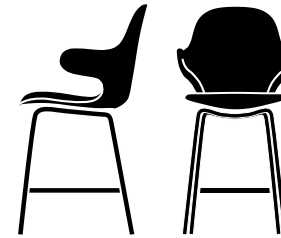

## CATCH BAR STOOL

&TRADITION IS PLEASED TO ANNOUNCE A NEW ADDITION TO THE CATCH SERIES BY THE ACCLAIMED DESIGNER JAIME HAYON: THE CATCH BAR STOOL. WITH THE SAME WELCOMING SPIRIT OF ITS FAMILY, THE BAR STOOL IS A CONVERSATION PIECE THAT INVITES FOR SOCIAL MOMENTS.

BY JAIME HAYON

Hayon brings the same welcoming spirit of his Catch Chairs to the Catch Bar Stool. Like a friend ready to give you a hug, the arms extend outwards from the curved seat. The result is a bar stool that's a conversation piece, setting the scene for a cosy exchange from the start. The bases are tubes powder coated black and available in two heights, with an enormous array of fabrics and leather types to choose from for the seat itself. It's the utmost in humanity and simplicity with a touch of humour.

"Hayon has a talent for creating inviting designs imbued with a certain energy," notes &tradition CEO Martin Kornbek Hansen. "The Catch Bar Stool and Counter Stool are no exception. Whether you're relaxing at home or out at a bar or lounge with others, the Catch Bar Stool and Counter Stool are an open invitation to meet, greet and start a conversation." As Hayon sees it, "Everyone takes design so seriously. My idea behind the Catch collection is to instantly make people feel welcome. That's why the seat is curvy and comfy with outstretched arms. Like a friend waiting for you."





IN BETWEEN SK1 & SK3, MASS LIGHT NA5



FLY SOFA SC12, FLY TABLE SC4, FLY CHAIR SC10 & SC1,  
COPENHAGEN PENDANT SC6, THE MOOR RUG AP5





TRICOLORE SH1-SH3



PALETTE DESK JH9, CATCH CHAIR JH2,  
WORKING TITLE DESK LAMP HK1





IN BETWEEN SK2 & SK5, COPENHAGEN PENDANT SC8,  
TRUE COLOURS LP1 & LP5



CATCH LOUNGE JH13, MARBLE LIGHT SV6



MAYOR AJ5, PALETTE JH7, THE MOOR RUG AP5,  
BELLEVUE FLOOR AJ7





FLY SOFA SC3, FLY CHAIR SC10,  
FLY TABLE SC11, THE MOOR RUG AP6



FORNELL ABF1, TRUE COLOURS LP6,  
PALETTE DESK JH9





IN BETWEEN SK7, MARBLE LIGHT SV2 & SV4



IN BETWEEN SK5, CATCH CHAIR JH15, FORNELL ABF1















## The Designers

All The Way To Paris  
 Andreas Bozarth Fornell  
 Arne Jacobsen  
 Benjamin Hubert  
 Flemming Lassen  
 Harri Koskinen  
 Isabell Gatzert  
 Jaime Hayon  
 Jørn Utzon  
 Lex Pott  
 Luca Nichetto  
 Mia Hamborg  
 Nendo  
 Norm Architects  
 Ontwerpduo  
 Sami Kallio  
 Samuel Wilkinson  
 Sebastian Herkner  
 Sofie Refer  
 Space Copenhagen  
 Studio Vit  
 Verner Panton  
 Victor Vetterlein

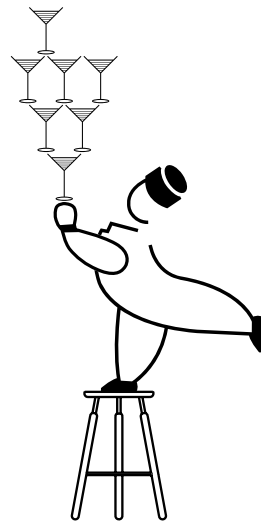

## CLOUD ONE SEATER LN1

BY LUCA NICHETTO  
 2015

**Product category** Lounge chair  
**Materials** Structure in wood and metal with no-zag springs. CMHR foam, Comforell and feather pillows. Solid steel legs. Fabric or leather upholstery.  
**Dimensions (cm/in)** H: 75cm/29.5in, D: 84cm/33in, L: 100cm/39.3in. Seat height: 40cm/15.7in.  
**8 wks. lead-time** All fabrics, leathers and COM available with chromed, bronzed or warm black powder coated legs.

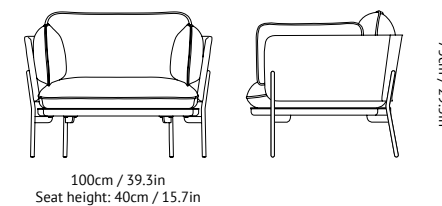

## CLOUD POUF LN4

BY LUCA NICHETTO  
 2015

**Product category** Pouf  
**Materials** Structure in wood and metal with no-zag springs. CMHR foam, Comforell and feather pillows. Solid steel legs. Fabric or leather upholstery.  
**Dimensions (cm/in)** H: 40cm/15.7in, D: 72cm/28.3in, L: 78cm/30.7in. Seat height: 40cm/15.7in.  
**8 wks. lead-time** All fabrics, leathers and COM available with chromed, bronzed or warm black powder coated legs.

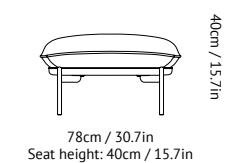





## CLOUD TWO SEATER LN2

BY LUCA NICHETTO  
2015

**Product category** Sofa  
**Materials** Structure in wood and metal with no-zag springs. CMHR foam, Comforell and feather pillows. Solid steel legs. Fabric or leather upholstery.  
**Dimensions (cm/in)** H: 75cm/29.5in, D: 84cm/33in, L: 168cm/66in. Seat height: 40cm/15.7in.  
**8 wks. lead-time** All fabrics, leathers and COM available with chromed, bronzed or warm black powder coated legs.

## CLOUD THREE SEATER LN3.2

BY LUCA NICHETTO  
2015

**Product category** Sofa  
**Materials** Structure in wood and metal with no-zag springs. CMHR foam, Comforell and feather pillows. Solid steel legs. Fabric or leather upholstery.  
**Dimensions (cm/in)** H: 75cm/29.5in, D: 84cm/33in, L: 220cm/86.5in. Seat height: 40cm/15.7in.  
**8 wks. lead-time** All fabrics, leathers and COM available with chromed, bronzed or warm black powder coated legs.

## CLOUD HIGH BACK LN6

BY LUCA NICHETTO  
2017

**Product category** High back sofa  
**Materials** Plywood frame. Solid wood & steel base with no-zag springs. CMHR foam, Comforell and feather pillows. Solid steel legs. Fabric or upholstery.  
**Dimensions (cm/in)** H: 115 cm/45.3in, D: 90cm/35.4in, W: 180cm/70.9in. Seat height: 40cm/15.7in.  
**8 wks. lead-time** All fabrics, leathers and COM available with chromed, bronzed or warm black powder coated legs.

## CLOUD HIGH BACK LN7

BY LUCA NICHETTO  
2017

**Product category** High back sofa  
**Materials** Plywood frame. Solid wood & steel base with no-zag springs. CMHR foam, Comforell and feather pillows. Solid steel legs. Fabric upholstery.  
**Dimensions (cm/in)** H: 115cm/45.3in, D:90cm/35.4in., W:232cm/91.3in. Seat height: 40cm/15.7in.  
**8 wks. lead-time** All fabrics, leathers and COM available with chromed, bronzed or warm black powder coated legs.

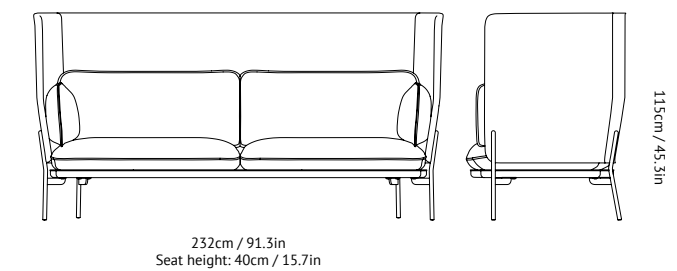
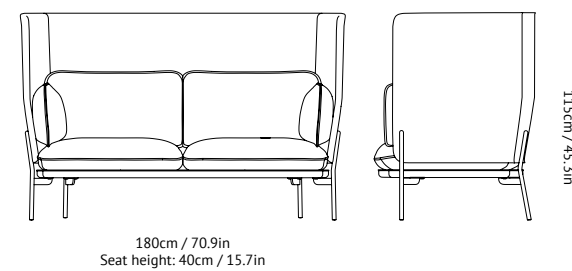
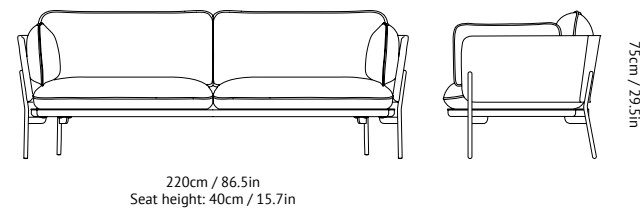
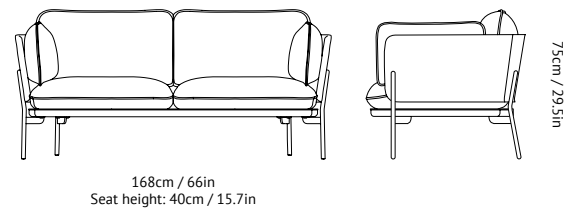





# ISOLE NN1

BY NENDO & LUCA NICHETTO  
2017

**Product category** Module sofa  
**Materials** Powder coated steel base, moulded CMHR foam seat, backrest and armrest. Black MDF table tops with nano laminate surface.

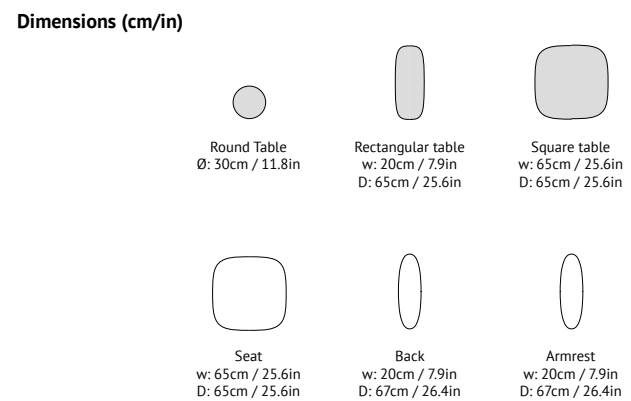

**Standard table top** Black  
**Standard upholstery** Uniform, Uniform Melange from Febrik.  
**8 wks. lead-time** All fabrics available with black powder coated steel base.

## Configurations examples

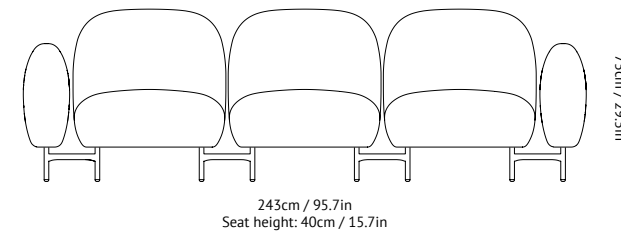
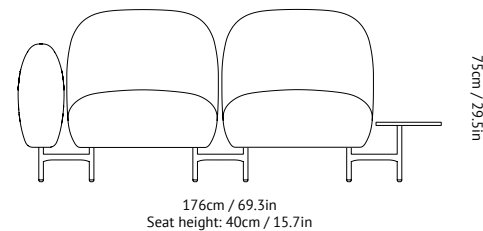
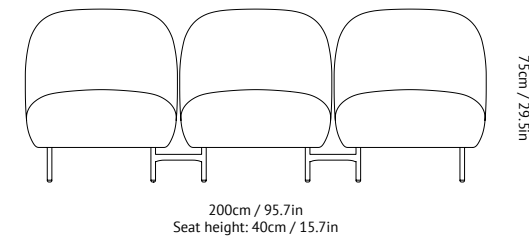
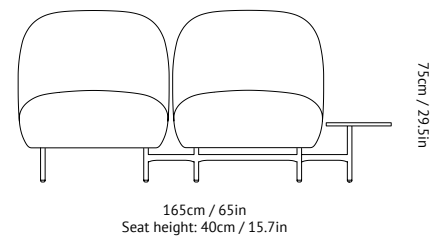
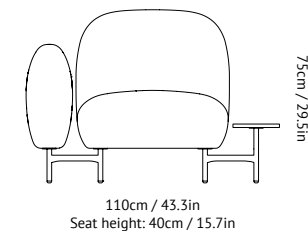
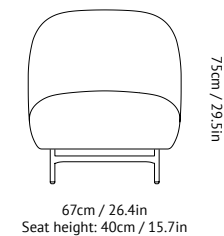
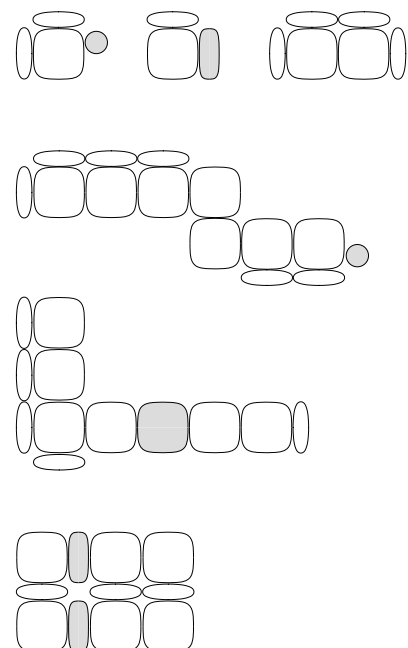



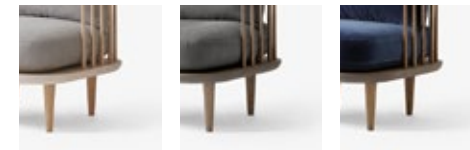

## MAYOR SOFA AJ5

BY ARNE JACOBSEN & FLEMMING LASSEN  
1939

**Product category** Sofa  
**Materials** Solid oak base, solid beech frame, CMHR foam, fabric or leather upholstery.  
**Dimensions (cm/in)** H: 82cm/32.3in, D: 62cm/24.4in, L: 200cm/78.7in, Seat height: 40cm/15.7in.  
**Stock items** White oiled oak with Hallingdal 130.  
**6 wks. lead-time** All fabrics, leathers and COM available with white oiled, smoked oiled or black stained solid oak base.

## FLY CHAIR SC10

BY SPACE COPENHAGEN  
2017

**Product category** Lounge chair  
**Materials** Oak frame and base. CMHR foam and feather pillows. Fabric upholstery.  
**Dimensions (cm/in)** H: 70cm/27.6in, D: 70cm/27.6in, L: 73cm/28.7in, Seating height: 40cm/15.7in.  
**Stock items** White oiled oak/Chivasso Hot Madison (CH1249/094), Smoked oiled oak/Chivasso Hot Madison (CH1249/093), Smoked oiled oak/Harald 182.  
**6 wks. lead-time** All other fabrics, leathers and COM available with white oiled or smoked oiled oak base and frame.

## FLY CHAIR SC1

BY SPACE COPENHAGEN  
2013

**Product category** Lounge chair  
**Materials** Oak frame and base. CMHR foam and feather pillows. Fabric upholstery.  
**Dimensions (cm/in)** H: 70cm/27.6in, D: 80cm/31.5in, L: 87cm/34.3in, Seat height: 40cm/15.7in.  
**Stock items** White oiled oak/Chivasso Hot Madison (CH1249/094), Smoked oiled oak/Chivasso Hot Madison (CH1249/093), Smoked oiled oak/Harald 182.  
**6 wks. lead-time** All other fabrics, leathers and COM available with white oiled or smoked oiled oak base and frame.

## FLY POUF SC9

BY SPACE COPENHAGEN  
2014

**Product category** Pouf  
**Materials** Oak base. CMHR foam and feather pillow. Fabric upholstery.  
**Dimensions (cm/in)** H: 40cm/15.7in, D: 80cm/31.5in, L: 80cm/31.5in, Seat height: 40cm/15.7in.  
**Stock items** White oiled oak/Chivasso Hot Madison (CH1249/094), Smoked oiled oak/Chivasso Hot Madison (CH1249/093), Smoked oiled oak/Harald 182.  
**6 wks. lead time** All other fabrics, leathers and COM available with white oiled or smoked oiled oak base and frame.

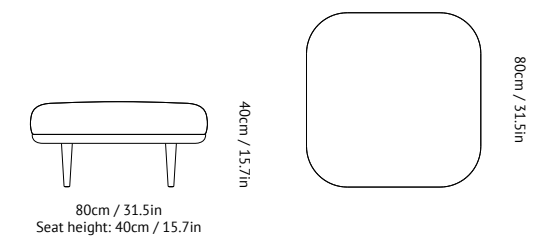
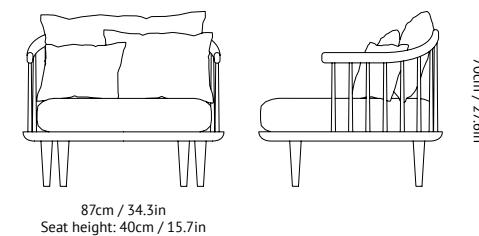
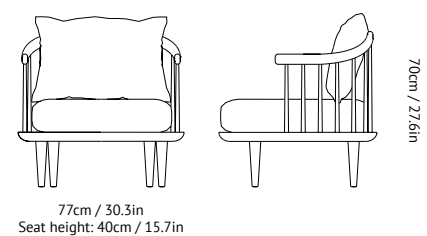
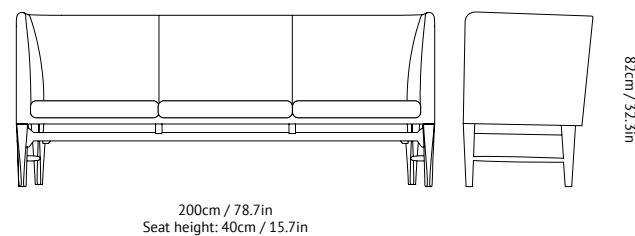

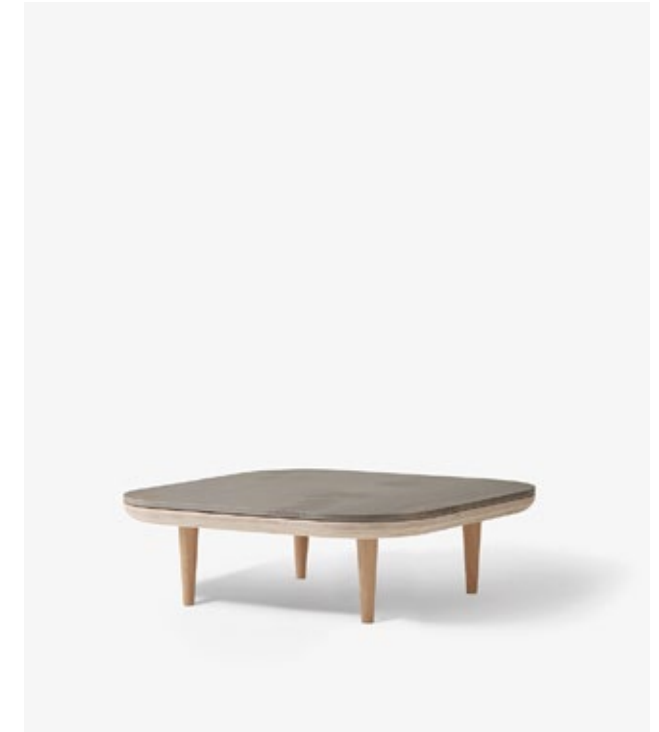
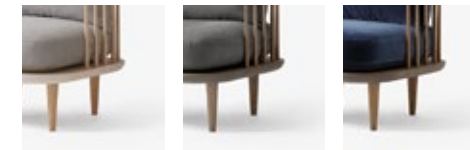
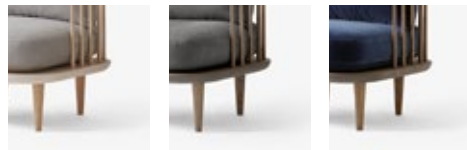

## FLY SOFA SC2

BY SPACE COPENHAGEN  
2013

**Product category** Sofa  
**Materials** Oak frame and base. CMHR foam and feather pillows. Fabric upholstery.  
**Dimensions (cm/in)** H: 70cm/27.6in, D: 80cm/31.5in, L: 162cm/63.8in. Seat height: 40cm/15.7in.  
**Stock items** White oiled oak/Chivasso Hot Madison (CH1249/094), Smoked oiled oak/Chivasso Hot Madison (CH1249/093), Smoked oiled oak/Harald 182.  
**6 wks. lead-time** All other fabrics, leathers and COM available with white oiled or smoked oiled oak base and frame.

## FLY SOFA SC3

BY SPACE COPENHAGEN  
2013

**Product category** Sofa with side tables  
**Materials** Oak frame and base. CMHR foam and feather pillows. Fabric upholstery.  
**Dimensions (cm/in)** H: 70cm/27.6in, D: 80cm/31.5in, L: 240cm/94.5in. Seat height: 40cm/15.7in.  
**Stock items** White oiled oak/Chivasso Hot Madison (CH1249/094), Smoked oiled oak/Chivasso Hot Madison (CH1249/093), Smoked oiled oak/Harald 182.  
**6 wks. lead-time** All other fabrics, leathers and COM available with white oiled or smoked oiled oak base and frame.

## FLY SOFA SC12

BY SPACE COPENHAGEN  
2017

**Product category** Sofa  
**Materials** Oiled oak frame and base. CMHR foam and feather pillows. Fabric upholstery.  
**Dimensions (cm/in)** H: 70cm/27.6in, D: 80cm/31.5in, L: 240cm/94.4in. Seating height: 40cm/15.7in.  
**Stock items** White oiled oak/Chivasso Hot Madison (CH1249/094), Smoked oiled oak/Chivasso Hot Madison (CH1249/093), Smoked oiled oak/Harald 182.  
**6 wks. lead-time** All other fabrics, leathers and COM available with white oiled or smoked oiled oak base and frame.

## FLY TABLE SC4

BY SPACE COPENHAGEN  
2013

**Product category** Lounge table  
**Materials** Oak base with marble table top.  
**Dimensions (cm/in)** H: 26cm/10.2in, D: 80cm/31.5in, L: 80cm/31.5in.  
**Colours** White oiled oak & honed Bianco Carrara marble, White oiled oak & honed Pietra di Fossena, Smoked oiled oak & honed Pietra di Fossena, Smoked oiled oak & honed Nero Marquina marble.

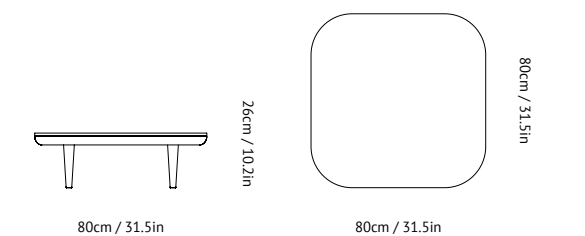
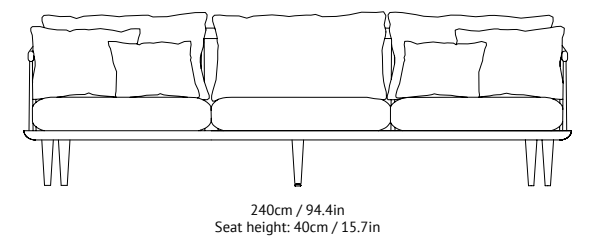
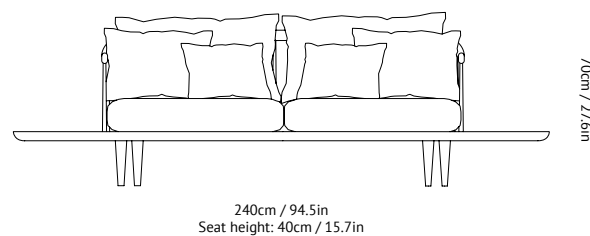
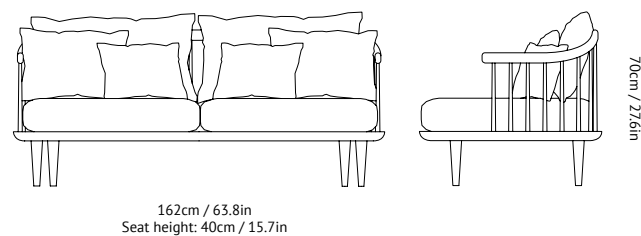





## FLY TABLE SC5

BY SPACE COPENHAGEN  
2013

**Product category** Lounge table  
**Materials** Oak base with marble table top.  
**Dimensions (cm/in)** H: 26cm/10.2in, D: 60cm/23.6in, L: 120cm/47.2in.  
**Stock items** White oiled oak & honed Bianco Carrara marble,  
 White oiled oak & honed Pietra di Fossena,  
 Smoked oiled oak & honed Pietra di Fossena,  
 Smoked oiled oak & honed Nero Marquina marble.

## FLY TABLE SC11

BY SPACE COPENHAGEN  
2017

**Product category** Lounge table  
**Materials** Oak base with marble table top.  
**Dimensions (cm/in)** H: 32cm/12.6in, D: 120cm/47.2in, L: 120cm/47.2in.  
**Stock items** White oiled oak & honed Bianco Carrara marble,  
 White oiled oak & honed Pietra di Fossena,  
 Smoked oiled oak & honed Pietra di Fossena,  
 Smoked oiled oak & honed Nero Marquina marble.

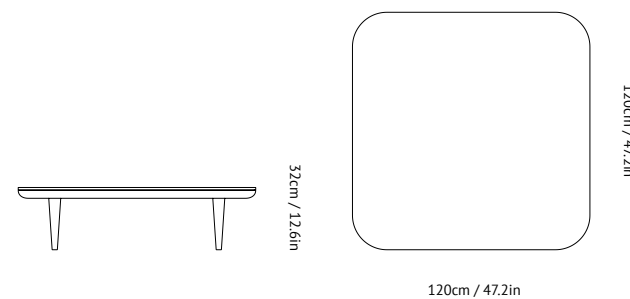
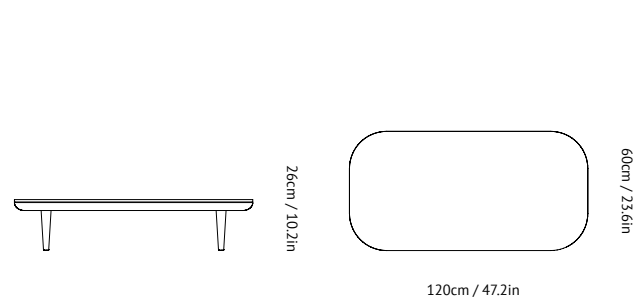

## CATCH LOUNGE JH13

BY JAIME HAYON  
2017

**Product category** Lounge chair  
**Materials** Molded PU foam, CMHR foam, steel base, fabric or leather upholstery.  
**Dimensions (cm/in)** H: 86cm/33.9in, W: 82cm/32.3in, D: 92cm/36.2in.  
 Armrest height: 58cm/22.8in.  
 Seat height: 36cm/14.2in.  
**6-8 wks. lead-time** Available in fabrics, leathers and as COM with warm black powder coated base.

## CATCH LOUNGE JH14

BY JAIME HAYON  
2017

**Product category** Lounge chair  
**Materials** Molded PU foam, CMHR foam, steel base, fabric or leather upholstery.  
**Dimensions (cm/in)** H: 86cm/33.9in, W: 82cm/32.3in, D: 92cm/36.2in.  
 Armrest height: 58cm/22.8in.  
 Seat height: 36cm/14.2in.  
**6-8 wks. lead-time** Available in fabrics, leathers and as COM with warm black powder coated base.

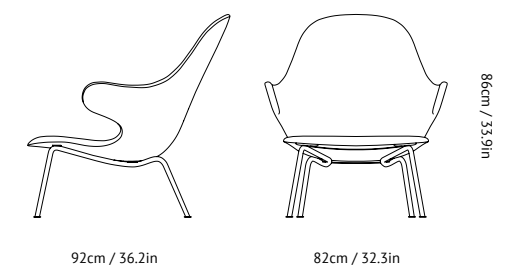
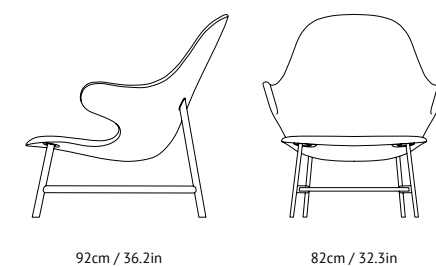

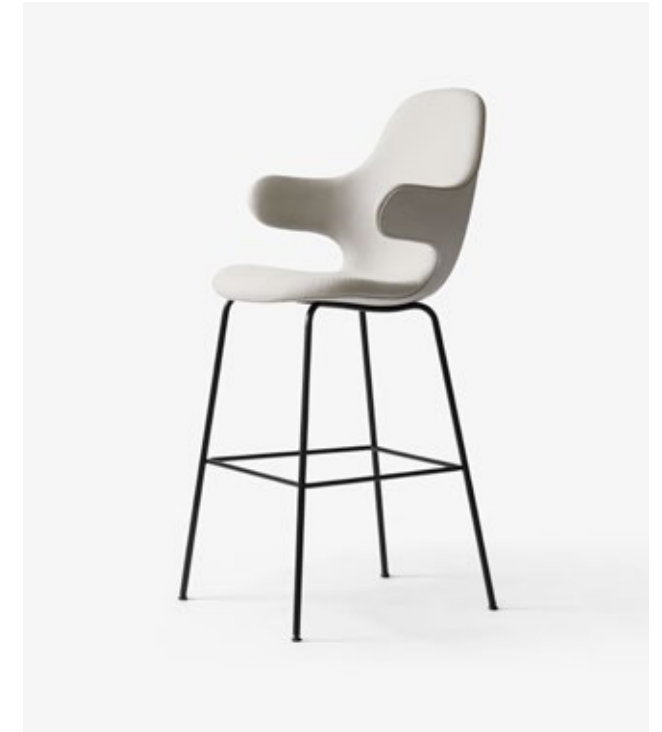
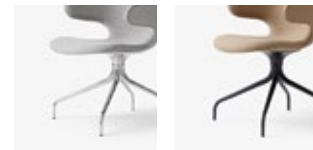
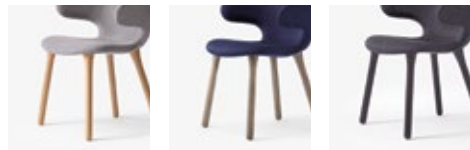

## CATCH CHAIR JH1

BY JAIME HAYON  
2014

**Product category** Chair with armrest  
**Materials** Molded PU foam, CMHR foam, oak legs, fabric or leather upholstery.  
**Dimensions (cm/in)** H: 90cm/35.4in, D: 58cm/22.8in, W: 58cm/22.8in.  
 Armrest height: 68cm/26.8in.  
 Seat height: 45cm/17.7in.  
**6-8 wks. lead-time** Available in fabrics, leathers and as COM with white oiled, smoked oiled, or black lacquered solid oak legs.

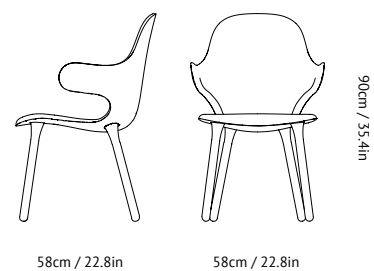

## CATCH CHAIR JH2

BY JAIME HAYON  
2014

**Product category** Chair with armrest  
**Materials** Molded PU foam, CMHR foam, aluminium swivel base, fabric or leather upholstery.  
**Dimensions (cm/in)** H: 90cm/35.4in, D: 58cm/22.8in, W: 58cm/22.8in.  
 Armrest height: 68cm/26.8in.  
 Seat height: 45cm/17.7in.  
**6-8 wks.lead-time** Available in fabrics, leathers and as COM with polished or black powder coated aluminium swivel base.

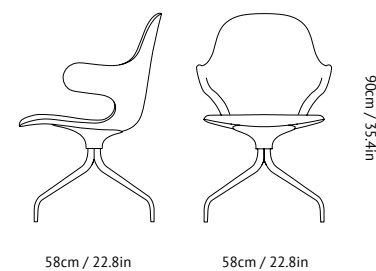

## CATCH CHAIR JH15

BY JAIME HAYON  
2017

**Product category** Chair with armrest  
**Materials** Molded PU foam, CMHR foam, steel tube base, fabric or leather upholstery.  
**Dimensions (cm/in)** H: 90cm/35.4in, D: 58cm/22.8in, W: 58cm/22.8in.  
 Armrest height: 68cm/26.8in.  
 Seat height: 45cm/17.7in.  
**6-8 wks. lead-time** Available in fabrics, leathers and as COM with black powder coated tube base.

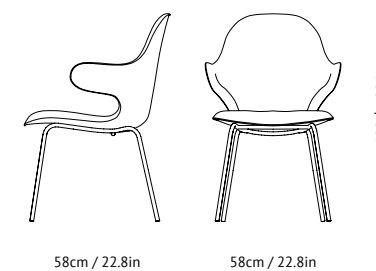

## CATCH BAR STOOL JH16 & JH17

BY JAIME HAYON  
2017

**Product category** Counter stool & Bar stool with armrests  
**Materials** Molded PU foam, CMHR foam, stell tube base, fabric or leather upholstery.  
**Dimensions (cm/in)** JH16: H: 107 cm/42.1in, D: 63cm/24.8in, W: 58cm/22.8in. Armrest height: 88 cm/34.6 in. Seating height: 66cm/26in.  
 JH17: H: 117 cm/46in, D: 63cm/24.8in,W: 58cm/22.8in. Armrest height: 98 cm/38.6 in. Seating height: 76 cm/30in.  
**6-8 wks. lead-time** Available in fabrics, leathers and as COM with black powder coated tube base.

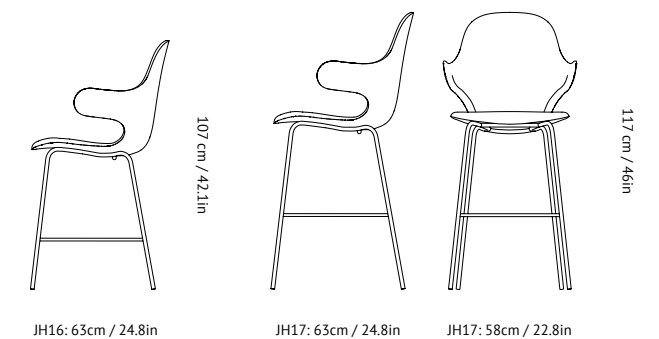



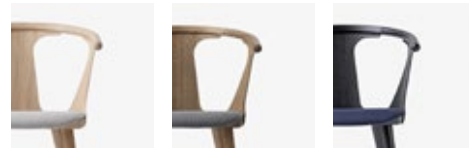
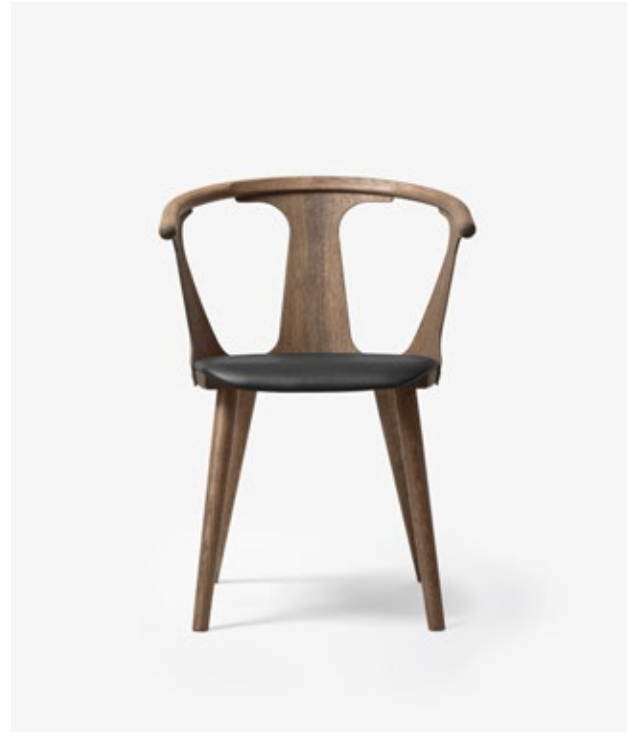

## IN BETWEEN SK1

BY SAMI KALLIO  
2013

**Product category** Chair with armrest  
**Materials** Solid oak and formpressed oak veneer.  
**Dimensions (cm/in)** H: 77cm/30.3in, W: 58cm/22.8in, D: 54cm/21.2in.  
 Armrest height: 70cm/27.6in.  
 Seat height: 45cm/17.7in.  
**Colours** White oiled oak, Smoked oiled oak, Black stained ash (RAL 9005).

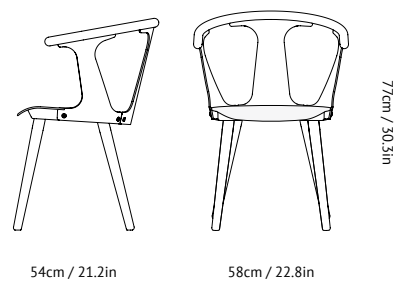

## IN BETWEEN SK2

BY SAMI KALLIO  
2013

**Product category** Chair with armrest  
**Materials** Solid oak and formpressed veneer.  
**Dimensions (cm/in)** H: 77cm/30.3in, W: 58cm/22.8in, D: 54cm/21.2in.  
 Armrest height: 70cm/27.6in.  
 Seat height: 45cm/17.7in.  
**Stock items** White oiled oak with Fiord 251,  
 White oiled oak with Cognac Silk leather,  
 Smoked oiled oak with Fiord 171,  
 Smoked oiled oak with Black Silk leather,  
 Black stained ash with Fiord 191,  
 Black stained ash with Black Silk leather.  
**6-8 wks. lead-time** Available in fabrics, leathers and as COM with white oiled, smoked oiled or black stained frame.

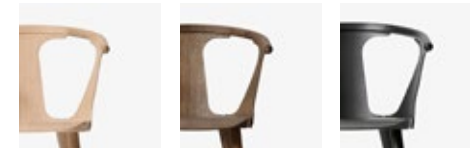
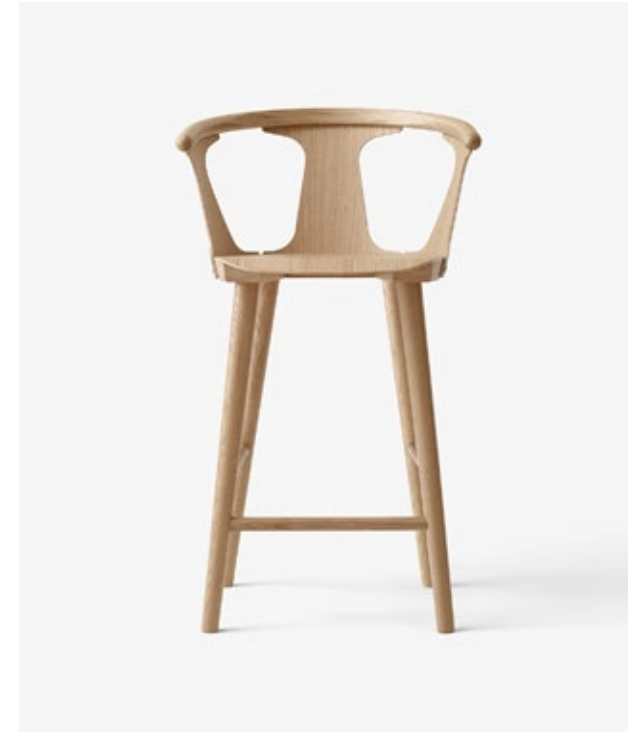
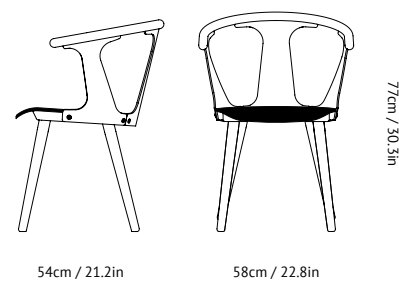

## IN BETWEEN SK7 & SK9

BY SAMI KALLIO  
2017

**Product category** Counter stool & Bar stool  
**Materials** Solid oak and formpressed oak veneer.  
**Dimensions (cm/in)** SK7: H: 92cm/36.2in, W: 58cm/22.8in, D: 54cm/21.2in. Armrest height: 88cm/34.6in. Seat height: 65cm/26.3in.  
 SK9: H: 102cm/40.2in, W: 58cm/22.8in, D: 54cm/21.2in. Armrest height: 98cm/38.6in. Seat height: 75cm/30.2in.  
**Stock items** White oiled oak, Smoked oiled oak, Black lacquered oak.

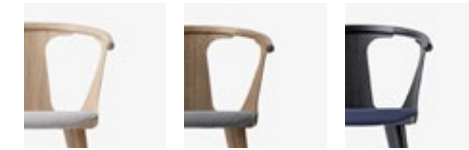
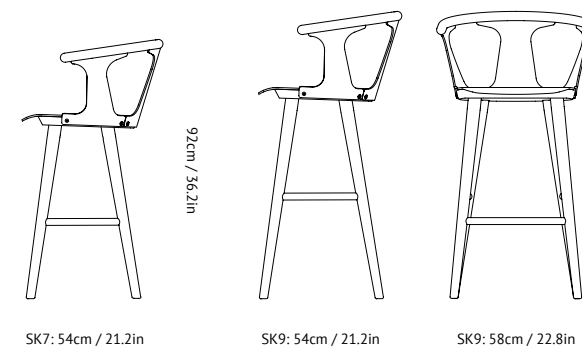

## IN BETWEEN SK8 & SK10

BY SAMI KALLIO  
2017

**Product category** Counter stool & Bar stool  
**Materials** Solid oak and formpressed oak veneer.  
**Dimensions (cm/in)** SK8: H: 92cm/36.2in, W: 58cm/22.8in, D: 54cm/21.2in. Armrest height: 88cm/34.6in. Seat height: 65cm/26.3in.  
 SK10: H: 102cm/40.2in, W: 58cm/22.8in, D: 54cm/21.2in. Armrest height: 98cm/38.6in. Seat height: 75cm/30.2in.  
**6-8 wks. lead-time** Available in fabrics, leathers and as COM with white oiled, smoked oiled or black stained frame.

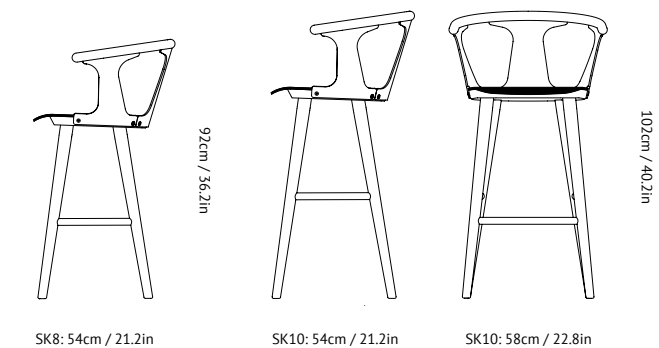



## IN BETWEEN SK3

BY SAMI KALLIO  
2014

**Product category** Dining table  
**Materials** Solid oak.  
**Dimensions (cm/in)** Ø: 90cm/35.4in, H: 73cm/28.7in.  
**Colours** White oiled oak, Smoked oiled oak, Black stained oak (RAL 9005).

## IN BETWEEN SK4

BY SAMI KALLIO  
2014

**Product category** Dining table  
**Materials** Solid oak.  
**Dimensions (cm/in)** Ø: 120cm/47.2in, H: 73cm/28.7in.  
**Colours** White oiled oak, Smoked oiled oak, Black stained oak (RAL 9005).



## IN BETWEEN SK5

BY SAMI KALLIO  
2015

**Product category** Dining table  
**Materials** Lacquered solid oak and oak veneer, Stained solid oak and oak veneer.  
**Dimensions (cm/in)** D: 200cm/78.7in, W: 90cm/35.4in, H: 73cm/28.7in.  
**Colours** Clear lacquered oak, Smoked stained oak, Black stained oak.  
**6-8 wks. lead-time** Available in custom sizes with veneer, laminate, nano laminate and linoleum table top upon request.



## IN BETWEEN SK6

BY SAMI KALLIO  
2015

**Product category** Dining table  
**Materials** Lacquered solid oak and oak veneer, Stained solid oak and oak veneer.  
**Dimensions (cm/in)** D: 250cm/98.4in, W: 100cm/39.4in, H: 73cm/28.7in.  
**Colours** Clear lacquered oak, Smoked stained oak, Black stained oak.  
**6-8 wks. lead-time** Available in custom sizes with veneer, laminate, nano laminate and linoleum table top upon request.

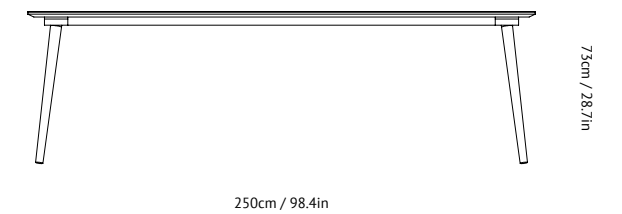
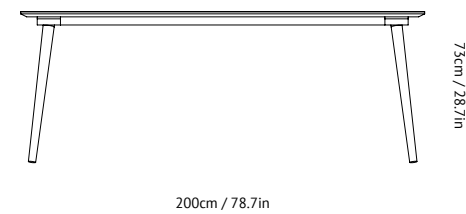
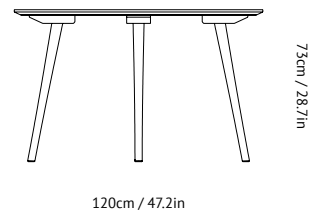
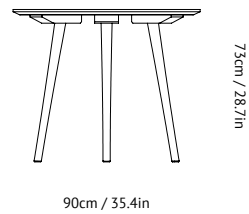





## HOOF TABLE SW1

BY SAMUEL WILKINSON  
2012

**Product category** Coffee table  
**Materials** Solid oak with a brushed surface.  
**Dimensions (cm/in)** Ø: 50cm/19.7in, H: 50cm/19.7in.  
**Colours** Solid white oiled oak,  
 Solid smoked oiled oak,  
 Solid black stained oak (RAL 9005).

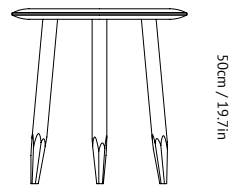

Ø: 50cm / 19.7in

50cm / 19.7in

## HOOF TABLE SW2

BY SAMUEL WILKINSON  
2012

**Product category** Coffee table  
**Materials** Solid oak with a brushed surface.  
**Dimensions (cm/in)** Ø: 90cm/35.4in, H: 40cm/15.7in.  
**Colours** Solid white oiled oak,  
 Solid smoked oiled oak,  
 Solid black stained oak (RAL 9005).

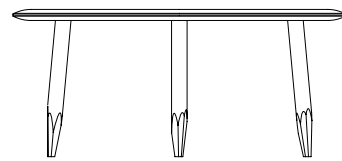

Ø: 90cm / 35.4in

40cm / 15.7in

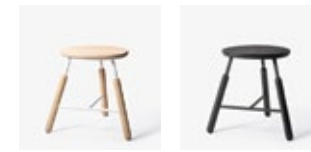

## NA STOOL NA3

BY NORM.ARCHITECTS  
2011

**Product category** Stool  
**Materials** Powdercoated steel and sandblasted solid oak.  
**Dimensions (cm/in)** H: 46cm/18.1in, D: 45cm/17.7in, W: 50cm/19.7in.  
**Colours** Natural oak with white powder coated steel (RAL 9016), Black stained oak with black powder coated steel (RAL 9005).

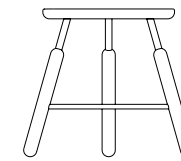

45cm / 17.7in

46cm / 18.1in

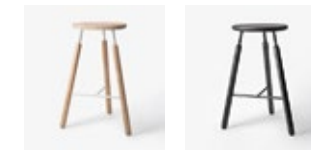
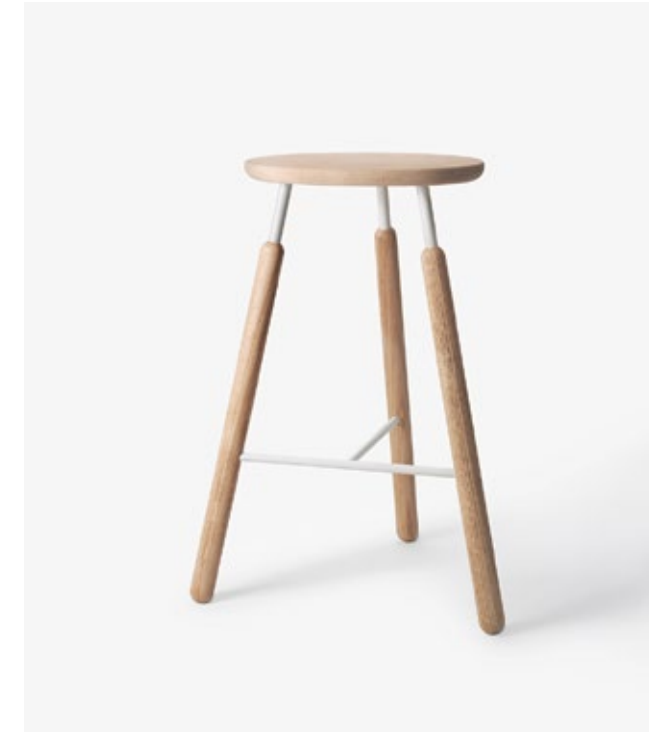

## NA BAR STOOL NA4

BY NORM.ARCHITECTS  
2011

**Product category** Bar stool  
**Materials** Powdercoated steel and sandblasted solid oak.  
**Dimensions (cm/in)** H: 73cm/28.7in, D: 45cm/17.7in, W: 50cm/19.7in.  
**Colours** Natural oak with white powder coated steel (RAL 9016), Black stained oak with black powder coated steel (RAL 9005).

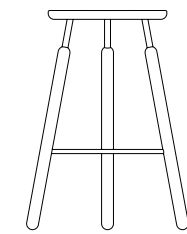

Ø: 45cm / 17.7in

73cm / 28.7in

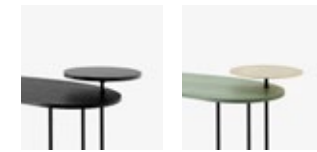

## PALETTE JH6

BY JAIME HAYON  
2015

**Product category** Lounge table  
**Materials** Stainless steel, white Bianco Carrara marble, pale pink stained ash.  
**Dimensions (cm/in)** D: 82.5cm/32.5in, W: 70.8cm/27.9in, H: 46.7cm/18.4in.

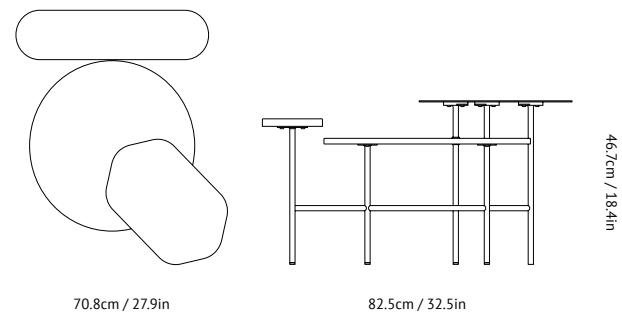

70.8cm / 27.9in  
82.5cm / 32.5in  
46.7cm / 18.4in

## PALETTE JH7

BY JAIME HAYON  
2015

**Product category** Lounge table  
**Materials** Brass, black Nero Marquina marble, black stained ash.  
**Dimensions (cm/in)** D: 115.2cm/45.4in, W: 67.8cm/26.7in, H: 47cm/18.5in.

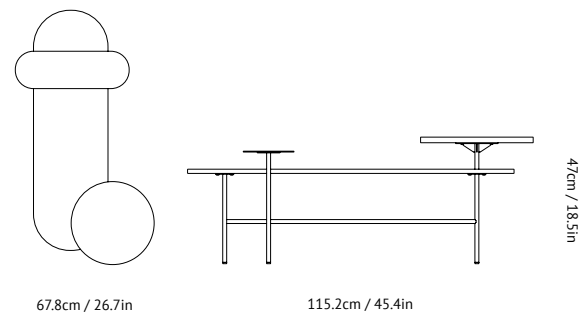

67.8cm / 26.7in  
115.2cm / 45.4in  
47cm / 18.5in

## PALETTE JH8

BY JAIME HAYON  
2015

**Product category** Lounge table  
**Materials** Brass, red Rosso Levanto marble, blue stained ash.  
**Dimensions (cm/in)** D: 66.3cm/26in, W: 54.9cm/21.6in, H: 57cm/22.4in.

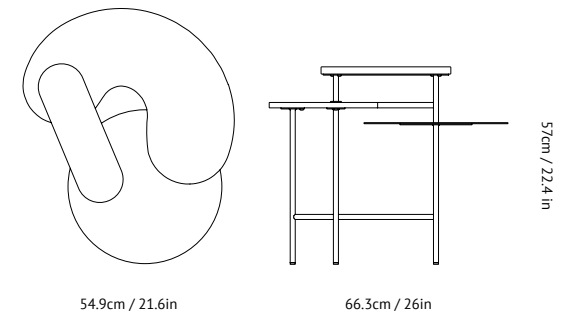

54.9cm / 21.6in  
66.3cm / 26in  
57cm / 22.4in

## PALETTE DESK JH9

BY JAIME HAYON  
2015

**Product category** Desk  
**Materials** Polished black Nero Marquina marble, black stained ash veneer. Satin polished brass, grey-green stained ash veneer.  
**Dimensions (cm/in)** H: 73/83cm/28.7/32.7in, D: 62cm/24.4in, L: 146cm/57.5in.

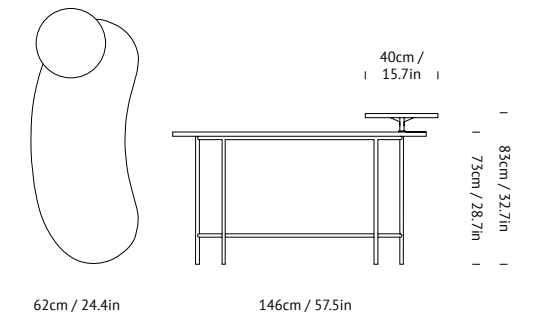

62cm / 24.4in  
146cm / 57.5in  
40cm / 15.7in  
73cm / 28.7in  
83cm / 32.7in



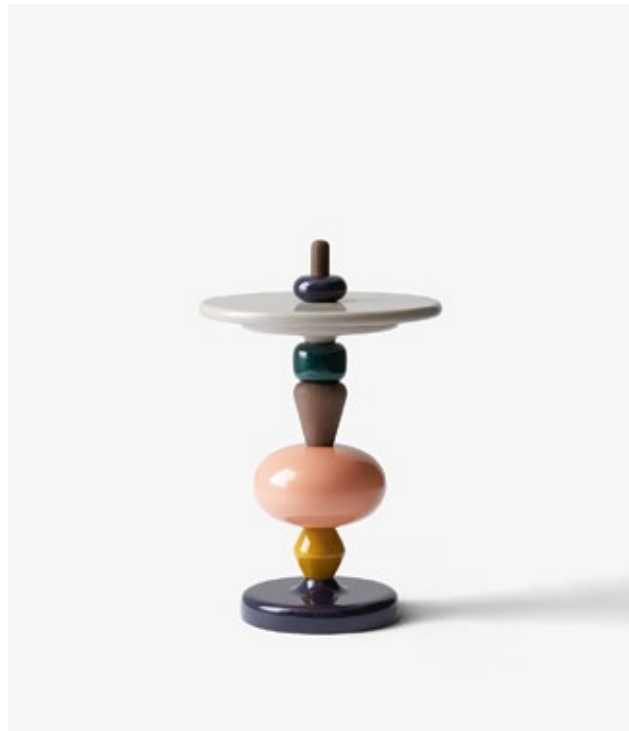

## SHUFFLE TABLE MH1

BY MIA HAMBORG  
BLACK EDITION BY PETER HAGEN  
2010

**Product category** Side table  
**Materials** PU Lacquered MDF, polished marble, PU lacquered solid beech, solid oiled oak.  
**Dimensions (cm/in)** Ø: 45cm/17.7in, H: 69cm/27.2in.  
**Colours** Black lacquered wood and polished Nero Marquina marble or Spectrum.

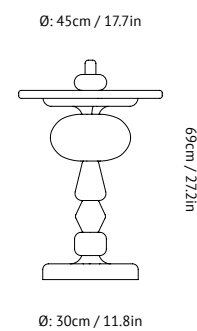

58

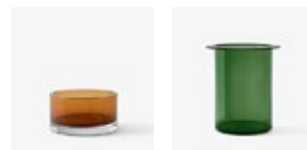

## TRICOLORE SH1

BY SEBASTIAN HERKNER  
2017

**Product category** Vases  
**Materials** Mouth-blown coloured bohemian glass.  
**Dimensions (cm/in)** Inner vase: Ø: 18cm/7.1in, H: 20cm/7.9in.  
Bottom vase: Ø: 17cm/6.7in, H: 9cm/3.5in.  
**Colours** Malachite & Cornaline

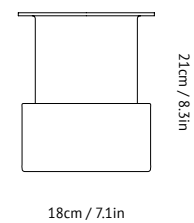

18cm / 7.1in



## TRICOLORE SH2

BY SEBASTIAN HERKNER  
2017

**Product category** Vases  
**Materials** Mouth-blown coloured bohemian glass.  
**Dimensions (cm/in)** Inner vase: Ø: 14cm/5.5in, H: 25cm/9.8in.  
Bottom vase: Ø: 13cm/5.1in x H: 17cm/6.7in.  
**Colours** Amber & Lapis

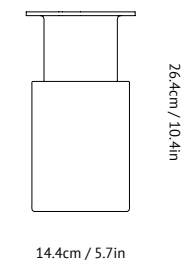

14.4cm / 5.7in

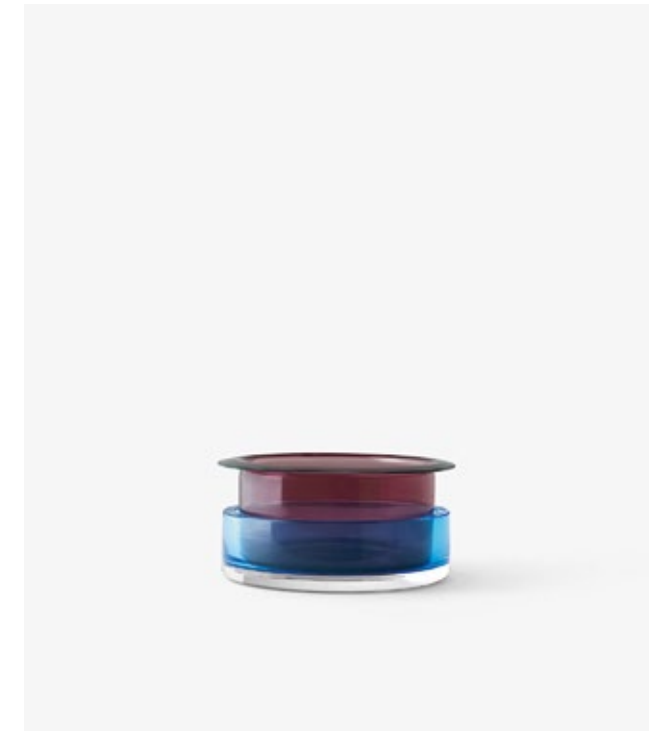

## TRICOLORE SH3

BY SEBASTIAN HERKNER  
2017

**Product category** Vases  
**Materials** Mouth-blown coloured bohemian glass.  
**Dimensions (cm/in)** Inner vase: Ø: 22cm/8.7in, H: 9cm/3.5in.  
Bottom vase: Ø: 21cm/8.3in, H: 6cm/2.3in.  
**Colours** Topaz & Rubis

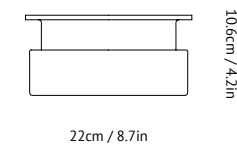

22cm / 8.7in

59

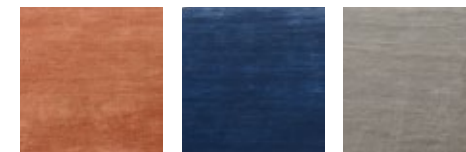
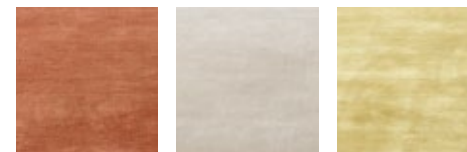
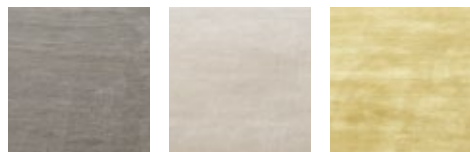

## THE MOOR AP5

BY ALL THE WAY TO PARIS  
2016

**Product category** Rug  
**Materials** Handloom-woven rug with a dense, soft and highly exclusive velvet-like expression made from 85% pure New Zealand wool, 15% viscose.  
**Dimensions (cm/in)** AP5: W: 170cm/66.9in, L: 240cm/94.5in.  
**Colours** Grey moss, Beige dew, Yellow field.



AP5: 240cm / 94.5in

## THE MOOR AP7

BY ALL THE WAY TO PARIS  
2016

**Product category** Rug  
**Materials** Handloom-woven rug with a dense, soft and highly exclusive velvet-like expression made from 85% pure New Zealand wool, 15% viscose.  
**Dimensions (cm/in)** AP7: W: 200cm/78.7in, L: 300cm/118.1in.  
**Colours** Grey moss, Beige dew.

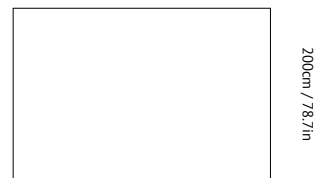

AP7: 300cm / 118.1in

## THE MOOR AP6

BY ALL THE WAY TO PARIS  
2016

**Product category** Rug  
**Materials** Handloom-woven rug with a dense, soft and highly exclusive velvet-like expression made from 85% pure New Zealand wool, 15% viscose.  
**Dimensions (cm/in)** W: 240cm/94.5in, L: 240cm/94.5in.  
**Colours** Red heather, Beige dew, Yellow field.

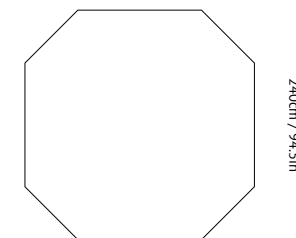

240cm / 94.5in

## THE MOOR AP8

BY ALL THE WAY TO PARIS  
2016

**Product category** Rug  
**Materials** Handloom-woven rug with a dense, soft and highly exclusive velvet-like expression made from 85% pure New Zealand wool, 15% viscose.  
**Dimensions (cm/in)** W: 300cm/118.1in, L: 300cm/118.1in.  
**Colours** Red heather, Blue midnight, Grey moss.

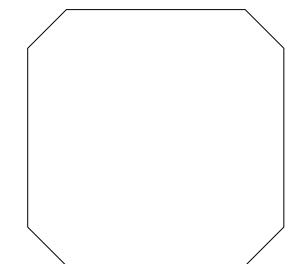

300cm / 118.1in



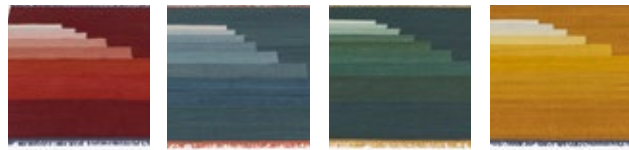
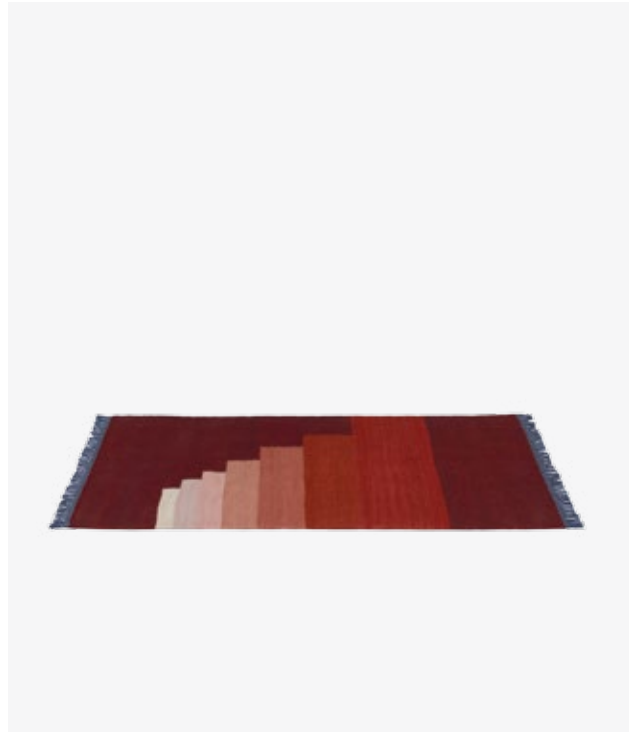

## ANOTHER RUG AP1 – AP4

BY ALL THE WAY TO PARIS  
2014

- Product category** Rug
- Materials** Handwoven kelim rug made from carefully selected natural materials.  
80% pure New Zealand wool, 20% cotton.
- Dimensions (cm/in)**  
AP1: W: 90cm/35.4in, L: 140cm/55.1in.  
AP2: W: 90cm/35.4in, L: 240cm/94.5in.  
AP3: W: 170cm/66.9in, L: 240cm/94.5in.  
AP4: W: 200cm/78.7in, L: 300cm/118.1in.
- Colours** Red Volcano, Blue Thunder, Green Jade, Yellow Amber.

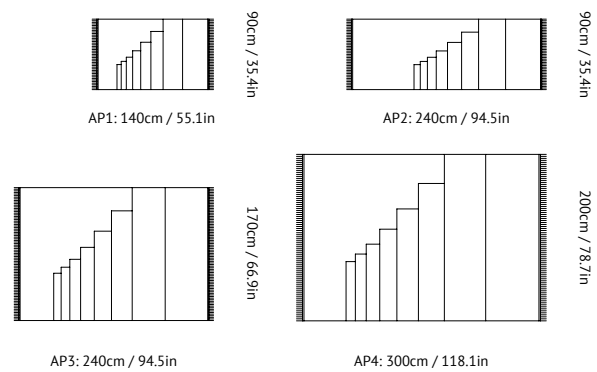

## TRUE COLOURS LP1 – LP7

BY LEX POTT  
2013

- Product category** Vases
- Materials** Brass, Aluminium, Copper, Steel.
- Dimensions (cm/in)**  
LP1: Ø: 10cm/3.9in, H: 20cm/7.9in.  
LP2: Ø: 10cm/3.9in, H: 24cm/9.4in.  
LP3: Ø: 8cm/3.1in, H: 20cm/7.9in.  
LP4: Ø: 8cm/3.1in, H: 10cm/3.9in.  
LP5: Ø: 10cm/3.9in, H: 14cm/5.5in.  
LP6: Ø: 6.5cm/2.6in, H: 16cm/6.3in.  
LP7: Ø: 8cm/3.1in, H: 18cm/7.1in.
- Colours** White aluminium, Terracotta brass, Green copper, Brown aluminium, Blue brass, Black brass, Brown steel.

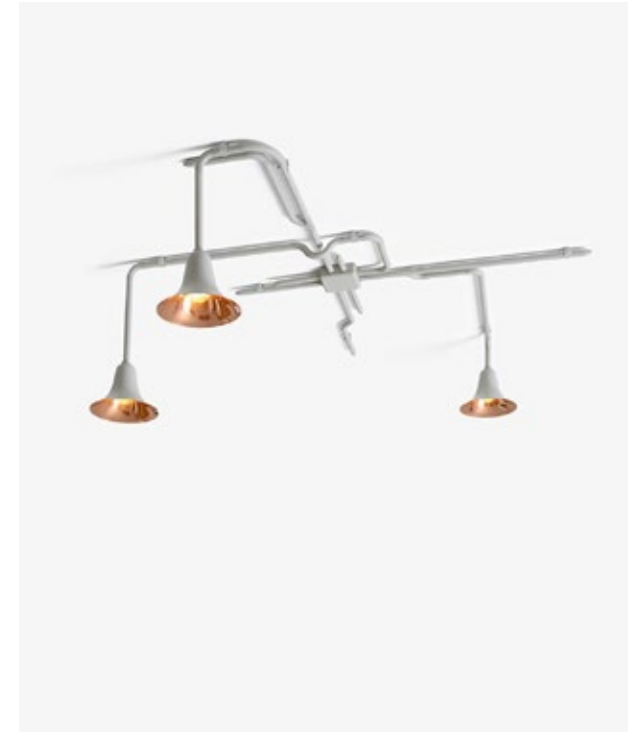
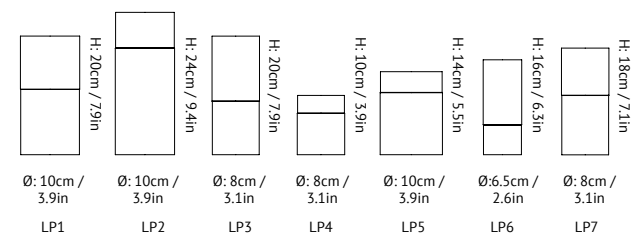

## LIGHT FOREST OD1

BY ONTWERPDUO  
2010

- Product category** Ceiling light
- Materials** Lacquered copper, aluminium and ABS.
- Dimensions (cm/in)**  
Conf. 1: W: 100cm/39.4in, D: 100cm/39.4in.  
Conf. 2: W: 125cm/49.2in, D: 120cm/47.2in.  
Conf. 3: W: 145cm/57.1in, D: 75cm/29.5in.  
Conf. 4: W: 100cm/39.4in, D: 75cm/29.5in.
- Colours** Slightly textured matt forest green.
- Light source** 3 x E27 Max 40 Watt. The luminaire is compatible with bulbs of the energy classes: A++ - E. Bulb is not included.

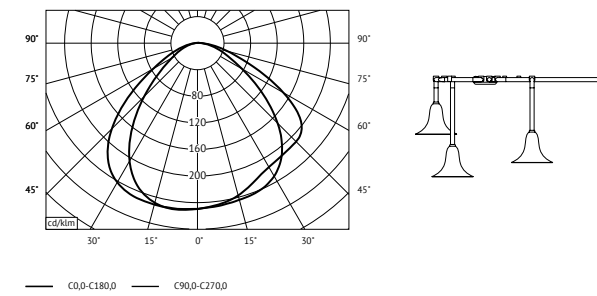

## LIGHT FOREST OD2

BY ONTWERPDUO  
2010

- Product category** Wall mounting set
- Materials** Lacquered copper, aluminium, ABS, 3-meter clear pvc cord with CE plug.
- Dimensions (cm/in)**  
Conf. 1: H: 120cm/47.2in, W: 70cm/27.6in.  
Conf. 2: H: 95cm/37.4in, W: 150cm/59.1in.
- Colours** Slightly textured matt forest green.
- Light source** 3 x E27 Max 40 Watt. The luminaire is compatible with bulbs of the energy classes: A++ - E. Bulb is not included.

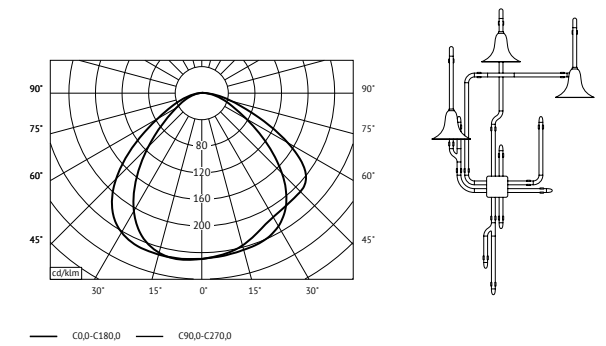



## FORNELL ABF1

BY ANDREAS BOZARTH FORNELL  
2017

- Product category** Pendant
- Materials** Mirror polished & matt lacquered stainless steel, PC diffuser, 6m cable & stainless steel wires
- Dimensions (cm/in)** Lamp shade: H: 6cm/2.4in, L: 120cm/47.2in, W: 7.5cm/2.9in. Canopy: H: 4cm/1.6in, L: 49cm/19.3in, W: 5cm/1.9in.
- Colours** Mirror polished stainless steel & matt black.  
Mirror polished stainless steel & matt white.
- Light source** Light source: 24 Watt dimmable LED.  
The luminaire is compatible with bulbs of the energy classes: A++ - A. The built-in LEDs cannot be changed in this luminaire.

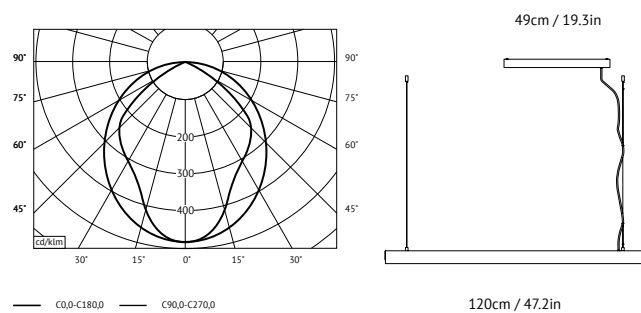

## WORKING TITLE HK1

BY HARRI KOSKINEN  
2017

- Product category** Desk lamp
- Materials** Hand polished aluminium & black PVC cord.
- Dimensions (cm/in)** H: 45cm/17.7in, L: 30cm/11.8in, W: 15cm/5.9in.
- Colours** Hand polished aluminium & black PVC cord.

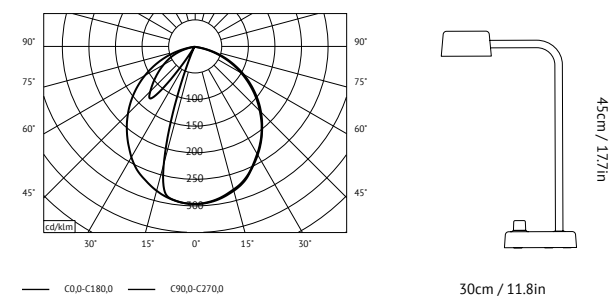

## MARBLE LIGHT SV2

BY STUDIO VIT  
2014

- Product category** Pendant
- Materials** White Bianco Carrara marble and clear mouth blown borosilicate glass with 4-meter white fabric cord.
- Dimensions (cm/in)** Marble: Ø: 8cm/3.1in, H: 10cm/3.9in.  
Glass: Ø: 13cm/5.1in.
- Light source** G9 Max 25 Watt. This luminaire is compatible with bulbs of the energy classes: B - E. Bulb is not included.

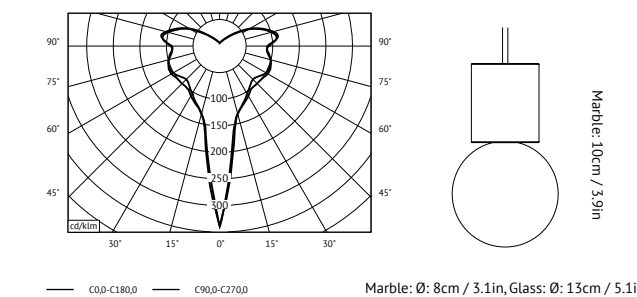

## MARBLE LIGHT SV3

BY STUDIO VIT  
2014

- Product category** Pendant
- Materials** White Bianco Carrara marble and clear mouth blown borosilicate glass with 4-meter white fabric cord.
- Dimensions (cm/in)** Marble: Ø: 7cm/2.7in, H: 5cm/1.9in.  
Glass: Ø: 8cm/3.1in.
- Light source** G9 Max 25 Watt. This luminaire is compatible with bulbs of the energy classes: B - E. Bulb is not included.

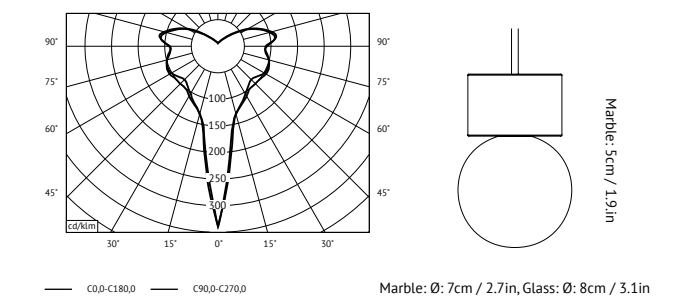





## MARBLE LIGHT SV4

BY STUDIO VIT  
2014

- Product category** Pendant
- Materials** White Bianco Carrara marble and clear mouth blown borosilicate glass with 4-meter white fabric cord.
- Dimensions (cm/in)** Marble: Ø: 9cm/3.5in, H: 6cm/2.3in.  
Glass: Ø: 11cm/4.3in.
- Light source** G9 Max 25 Watt. This luminaire is compatible with bulbs of the energy classes: B - E. Bulb is not included.

## MARBLE LIGHT SV5

BY STUDIO VIT  
2014

- Product category** Pendant
- Materials** White Bianco Carrara marble and clear mouth blown borosilicate glass with 4-meter white fabric cord.
- Dimensions (cm/in)** Marble: Ø: 5cm/1.9in, H: 16cm/6.3in.  
Glass: Ø: 16cm/6.3in.
- Light source** G9 Max 25 Watt. This luminaire is compatible with bulbs of the energy classes: B - E. Bulb is not included.

## MARBLE LIGHT SV6

BY STUDIO VIT  
2014

- Product category** Table lamp
- Materials** White Bianco Carrara marble and clear mouth blown borosilicate glass with 2-meter white fabric cord with dimmer.
- Dimensions (cm/in)** Marble: Ø: 7cm/2.7in, H: 5cm/1.9in.  
Glass: Ø: 16cm/6.3in.
- Light source** G9 Max 25 Watt. This luminaire is compatible with bulbs of the energy classes: B - E. Bulb is not included.

## MARBLE LIGHT SV7

BY STUDIO VIT  
2014

- Product category** Pendant (SV2) with marble floor weight and 10-meter cable.
- Materials** White bianco carrara marble with 10-meter white fabric cord fitted with G9 lamp holder. The floor weight is delivered with a white metal hook for ceiling installation and a self-assembly CE plug.
- Dimensions (cm/in)** Marble: Ø: 20cm/7.8in, H: 8cm/3.1in.
- Light source** G9 Max 25 Watt. This luminaire is compatible with bulbs of the energy classes: B - E. Bulb is not included.

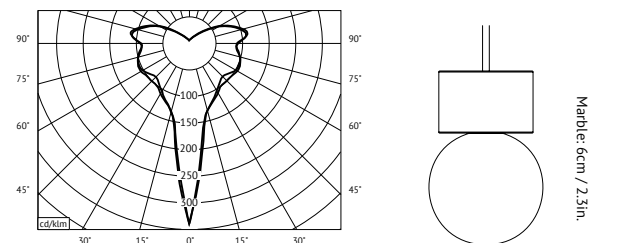

Marble: Ø: 9cm / 3.5in, Glass: Ø: 11cm / 4.3in

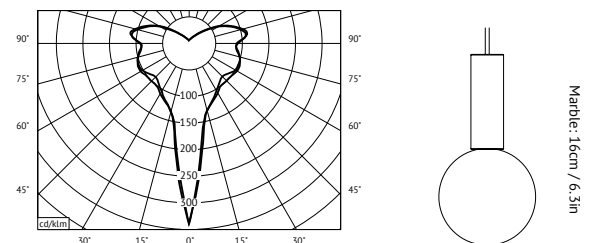

Marble: Ø: 5cm / 1.9in, Glass: Ø: 16cm / 6.3in

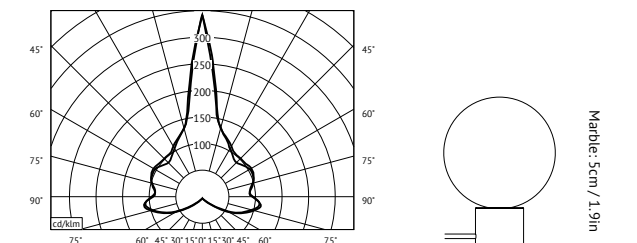

Marble: Ø: 7cm / 2.7in, Glass: Ø: 16cm / 6.3in

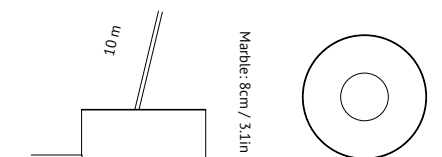

Ø: 20cm / 7.8in

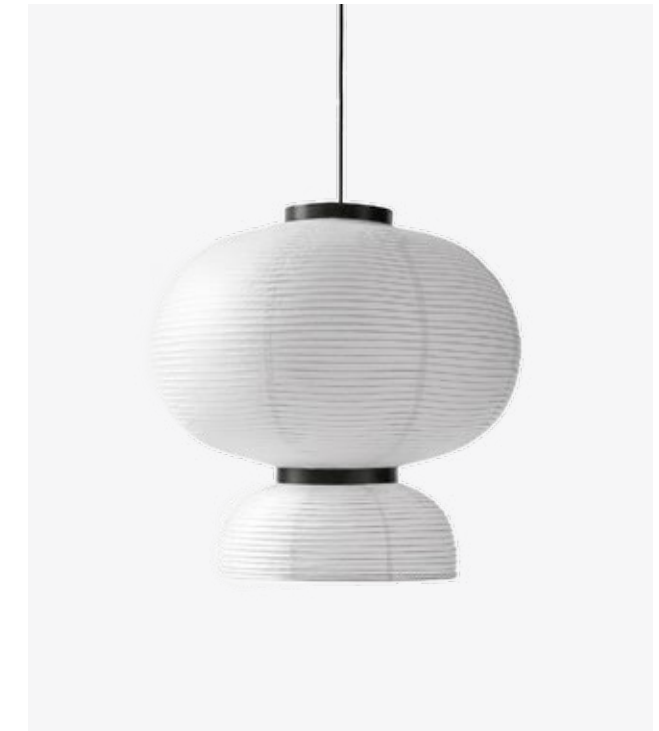
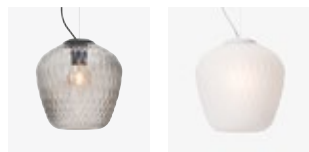
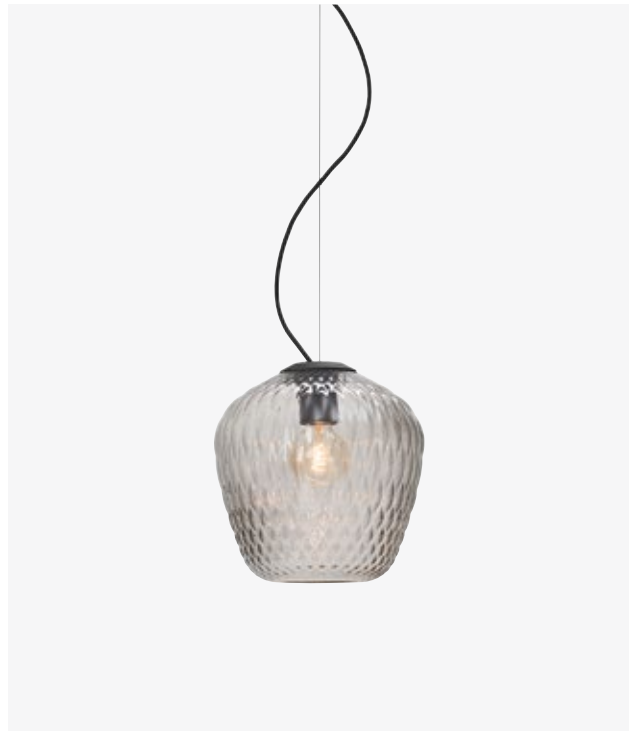

## BLOWN SW3

BY SAMUEL WILKINSON  
2014

**Product category** Pendant  
**Materials** Mouth-blown glass, powdercoated metal suspension, coated wire, 4-meter fabric cord.  
**Dimensions (cm/in)** Ø: 28cm/11in, H: 28cm/11in.  
**Colours** Silver lustre glass with black textile cord, Blasted white glass with white textile cord.  
**Light source** E27 Max 100 Watt. The luminaire is compatible with bulbs of the energy classes: A++ - E. Bulb is not included.

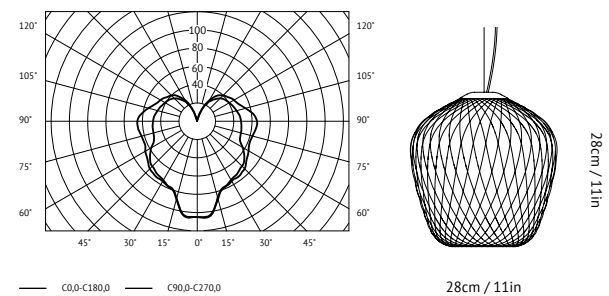

— C0-0-C180,0 — C90-0-C270,0

## FORMAKAMI JH3

BY JAIME HAYON  
2015

**Product category** Pendant  
**Materials** Ivory white paper, black stained oak, 4-meter black fabric cord.  
**Dimensions (cm/in)** Ø: 46cm/18.1in, H: 68cm/26.7in.  
**Colours** Ivory white paper with black stained oak.  
**Light source** E27 2 x Max 60 Watt.  
 The luminaire is compatible with bulbs of the energy classes: A++ - E. Bulb is not included.

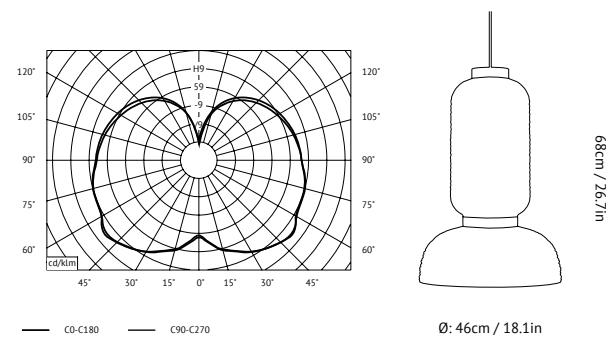

— C0-C180 — C90-C270

Ø: 46cm / 18.1in

## FORMAKAMI JH4

BY JAIME HAYON  
2015

**Product category** Pendant  
**Materials** Ivory white paper, black stained oak, 4-meter black fabric cord.  
**Dimensions (cm/in)** Ø: 50cm/19.7in, H: 50cm/19.7in.  
**Colours** Ivory white paper with black stained oak.  
**Light source** E27 2 x Max 60 Watt.  
 The luminaire is compatible with bulbs of the energy classes: A++ - E. Bulb is not included.

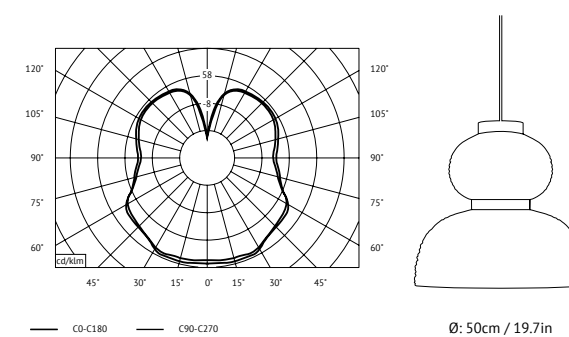

— C0-C180 — C90-C270

Ø: 50cm / 19.7in

## FORMAKAMI JH5

BY JAIME HAYON  
2015

**Product category** Pendant  
**Materials** Ivory white paper, black stained oak, 4-meter black fabric cord.  
**Dimensions (cm/in)** Ø: 70cm/27.6in, H: 74cm/29.1in.  
**Colours** Ivory white paper with black stained oak.  
**Light source** E27 2 x Max 60 Watt.  
 The luminaire is compatible with bulbs of the energy classes: A++ - E. Bulb is not included.

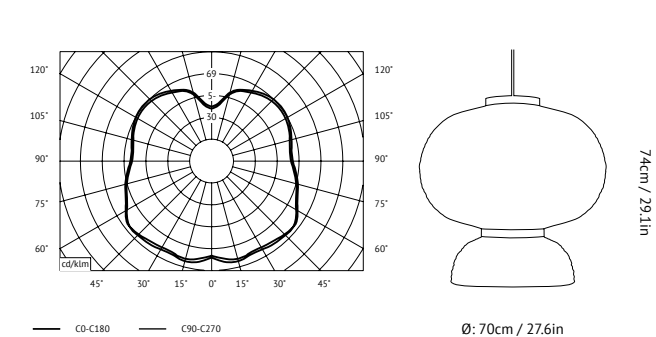

— C0-C180 — C90-C270

Ø: 70cm / 27.6in



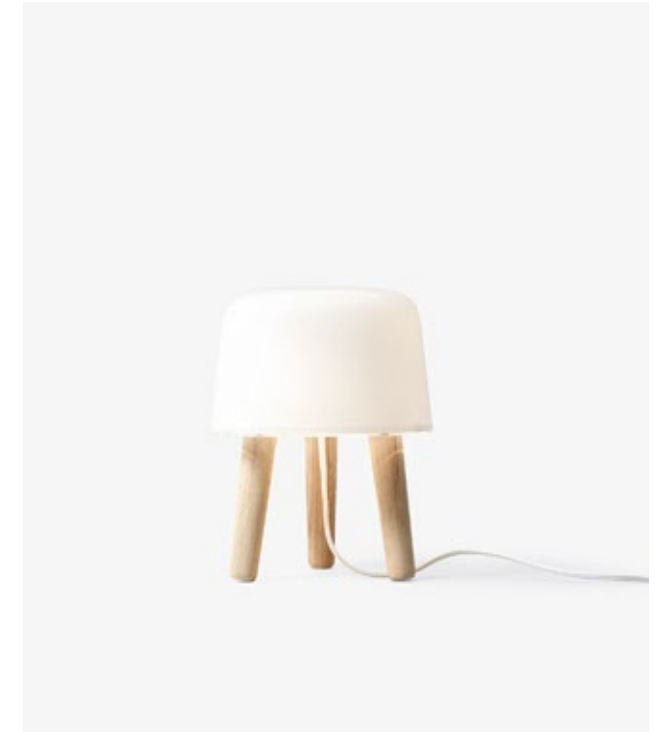
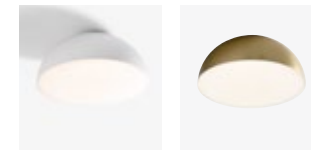
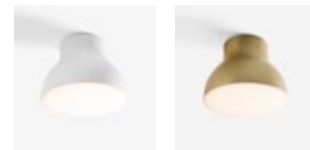

## PASSEPARTOUT JH10

BY JAIME HAYON  
2016

**Product category** Ceiling & wall lamp  
**Materials** Aluminium, Polycarbonate, ABS.  
**Dimensions (cm/in)** Ø: 15.5cm/6.1in, H: 17cm/6.7in.  
**Colours** Matt white, Gold.  
**Light source** 11,5 Watt dimmable LED. The luminaire is compatible with bulbs of the energy classes: A++ - A. The built-in LEDs cannot be changed in this luminaire.

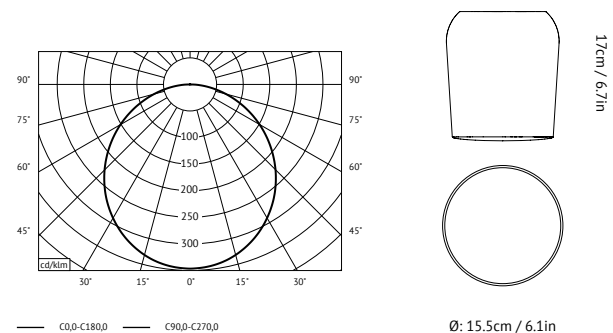

## PASSEPARTOUT JH11

BY JAIME HAYON  
2016

**Product category** Ceiling & wall lamp  
**Materials** Aluminium, Polycarbonate, ABS.  
**Dimensions (cm/in)** Ø: 20cm/7.9in, H: 15.5cm/6.1in.  
**Colours** Matt white, Gold.  
**Light source** 11,5 Watt dimmable LED. The luminaire is compatible with bulbs of the energy classes: A++ - A. The built-in LEDs cannot be changed in this luminaire.

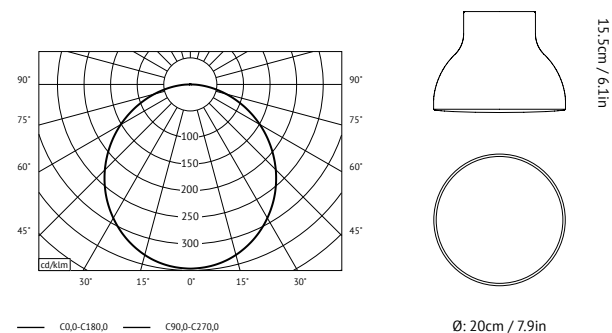

## PASSEPARTOUT JH12

BY JAIME HAYON  
2016

**Product category** Ceiling & wall lamp  
**Materials** Aluminium, Polycarbonate, ABS.  
**Dimensions (cm/in)** Ø: 28cm/11in, H: 12.5cm/4.9in.  
**Colours** Matt white, Gold.  
**Light source** 11,5 Watt dimmable LED. The luminaire is compatible with bulbs of the energy classes: A++ - A. The built-in LEDs cannot be changed in this luminaire.

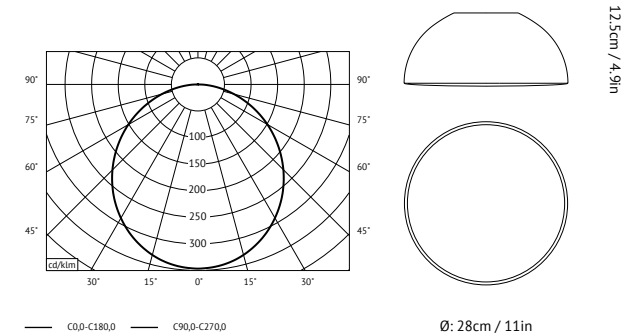

## MILK NA1

BY NORM.ARCHITECTS  
2010

**Product category** Table lamp  
**Materials** Mouth blown opal glass, solid ash legs, 2-meter fabric cord with dimmer.  
**Dimensions (cm/in)** Ø: 20cm/7.9in, H: 25cm/9.8in.  
**Colours** Untreated ash legs with white fabric cord, Untreated ash legs with black fabric cord, Smoked oiled ash legs with black fabric cord, Black stained ash legs with black fabric cord, G9 Max 40 Watt. The luminaire is compatible with bulbs of the energy classes: B - E. Bulb is not included.  
**Light source**

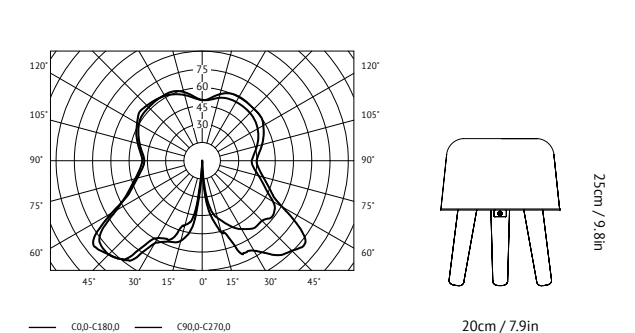

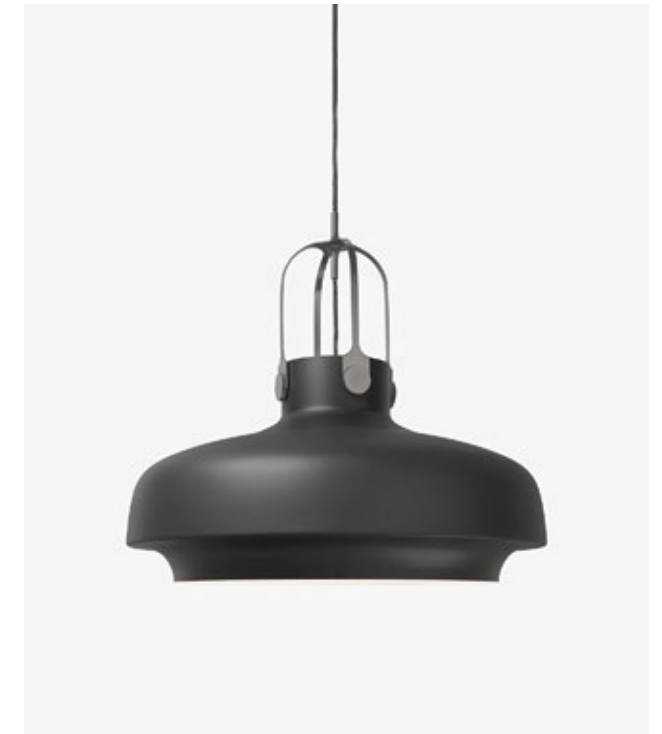
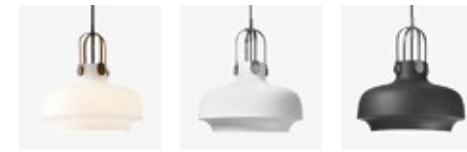
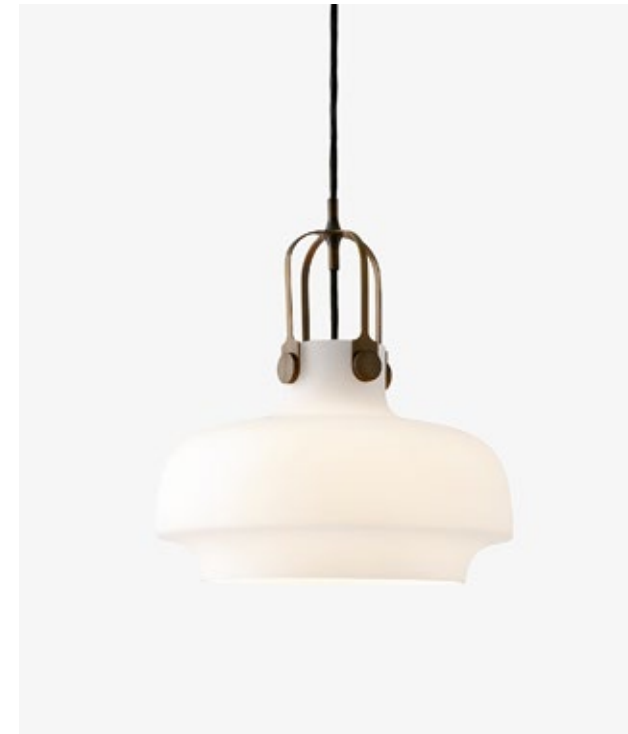

## TOPAN VP6

BY VERNER PANTON  
1959

- Product category** Pendant
- Materials** Lacquered aluminium with 3-meter fabric cord.
- Dimensions (cm/in)** Ø: 21cm/8.3in, H: 19cm/7.5in.
- Colours** Grey beige, White, Black blue, Dark green, Deep red.
- Light source** E27 Max 40 Watt. The luminaire is compatible with bulbs of the energy classes: A++ - E. Bulb is not included.

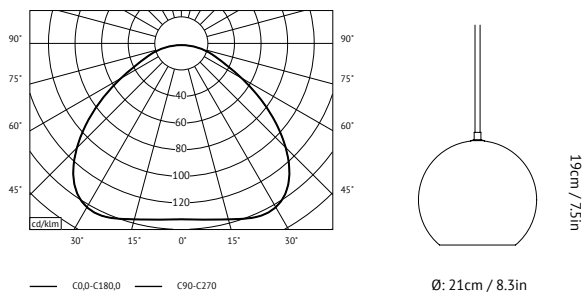

## COPENHAGEN PENDANT SC6

BY SPACE COPENHAGEN  
2014

- Product category** Pendant
- Materials** Lacquered steel shade with plated steel suspension or satinized opal glass shade with bronzed brass suspension, 4-meter black fabric cord.
- Dimensions (cm/in)** Ø: 20cm/7.8in, H: 25cm/9.8in.
- Colours** Opal glass, Matt white, Matt moss, Matt blush, Matt slate, Matt black.
- Light source** G9 Max 40 Watt. The luminaire is compatible with bulbs of the energy classes: B - E. Bulb is not included.

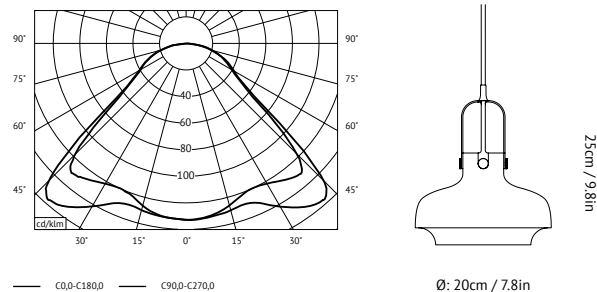

## COPENHAGEN PENDANT SC7

BY SPACE COPENHAGEN  
2014

- Product category** Pendant
- Materials** Lacquered steel shade with plated steel suspension or satinized opal glass shade with bronzed brass suspension, 4-meter black fabric cord.
- Dimensions (cm/in)** Ø: 35cm/13.8in, H: 40cm/15.7in.
- Colours** Opal glass, Matt black, Matt white.
- Light source** E27 Max 100 Watt. The luminaire is compatible with bulbs of the energy classes: A++ - E. Bulb is not included.

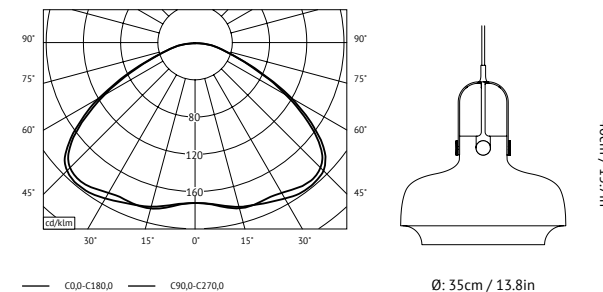

## COPENHAGEN PENDANT SC8

BY SPACE COPENHAGEN  
2014

- Product category** Pendant
- Materials** Lacquered aluminum shade with plated steel suspension, 6-meter fabric cord with safety wire.
- Dimensions (cm/in)** Ø: 60cm/23.6in, H: 53cm/20.7in.
- Colours** Matt black, Matt white.
- Light source** E27 Max 150 Watt. The luminaire is compatible with bulbs of the energy classes: A++ - E. Bulb is not included.

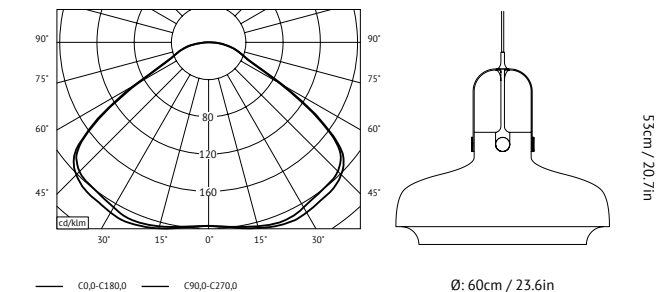



## SPINNING LIGHT BH1

BY BENJAMIN HUBERT  
2010

**Product category** Pendant  
**Materials** Lacquered aluminium with 4-meter PVC cord.  
**Dimensions (cm/in)** H: 45cm/17.7in, Ø: 25cm/9.8in.  
**Colours** Matt white, Matt dark grey, Matt black.  
**Light source** E27 Max 60 Watt. The luminaire is compatible with bulbs of the energy classes: A++ - E. Bulb is not included.

## SPINNING LIGHT BH2

BY BENJAMIN HUBERT  
2010

**Product category** Pendant  
**Materials** Lacquered aluminium with 4-meter PVC cord.  
**Dimensions (cm/in)** Ø: 40cm/15.7in, H: 34cm/13.4in.  
**Colours** Matt white, Matt dark grey, Matt black.  
**Light source** E27 Max 60 Watt. The luminaire is compatible with bulbs of the energy classes: A++ - E. Bulb is not included.

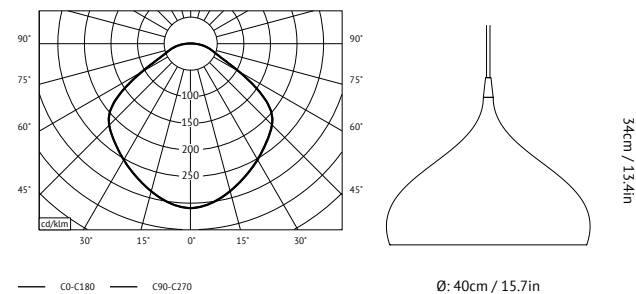
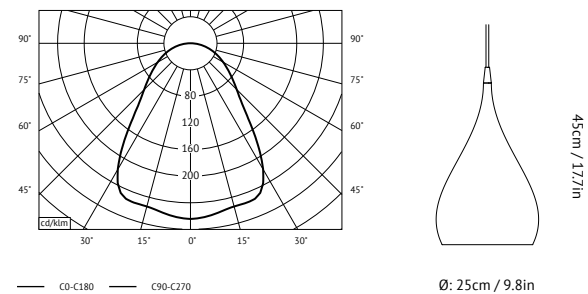

## UTZON LAMP JU1

BY JØRN UTZON  
1947

**Product category** Pendant  
**Materials** Lacquered metal, 3-meter fabric cord.  
**Dimensions (cm/in)** Ø: 22cm/8.7in, H: 23cm/9.1in.  
**Colours** White lacquered steel with white fabric cord, Brass with black fabric cord, Lacquered copper with black fabric cord.  
**Light source** E27 Max 60 Watt. The luminaire is compatible with bulbs of the energy classes: A++ - E. Bulb is not included.

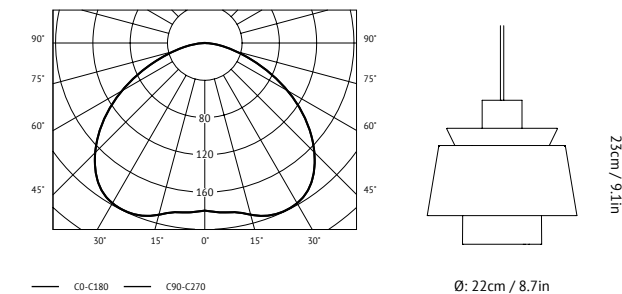

## ICE CHANDELIER SR6-SR10

BY SOFIE REFER  
2006

**Product category** Chandelier  
**Materials** Mouth-blown glass and anodised aluminium with clear PVC cord.  
**Dimensions (cm/in)** SR6: Ø: 38cm/14.9in, L: 180cm/70.8in. Custom sizes available upon request.  
**Colours** Clear glass with anodized aluminium, Silver lustre glass with black anodized aluminium, Gold lustre glass with gold anodized aluminium.  
**Light source** 9 x G4 Max 10 Watt. The luminaire is compatible with bulbs of the energy class: C. The luminaire is sold with a bulb of the energy class: C.

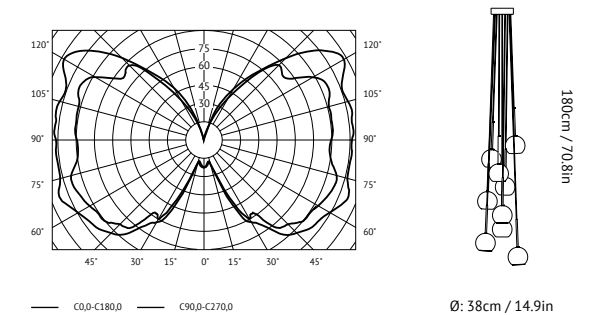



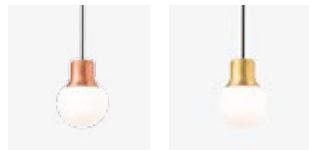
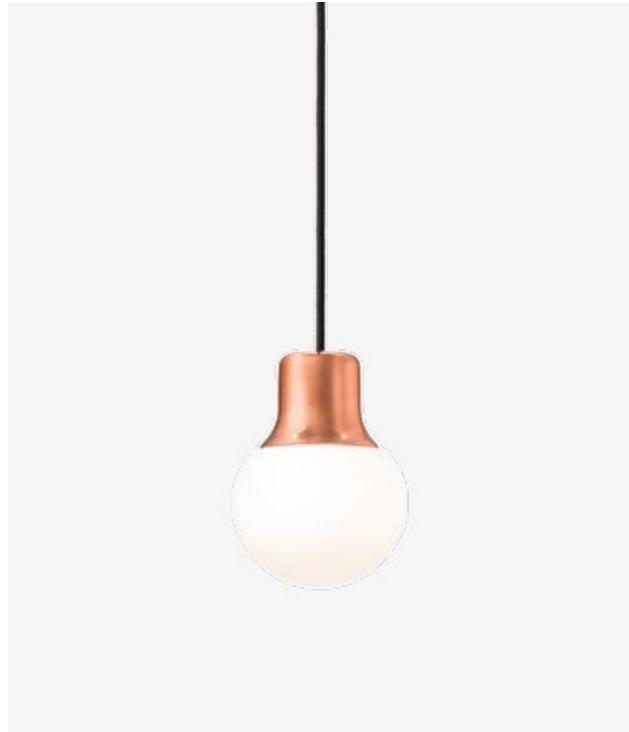

## MASS LIGHT NA5

BY NORM.ARCHITECTS  
2012

**Product category** Pendant  
**Materials** Copper or brass, white acid-etched opal glass, 4-meter black fabric cord. Mass Light can also be bought as a chandelier with a canopy for 9 pendants.  
**Dimensions (cm/in)** Ø: 12.6cm/5in, H: 18.3cm/7.2in.  
**Light Source** G9 Max 40 Watt. The luminaire is compatible with bulbs of the energy classes: B - E. Bulb is not included.

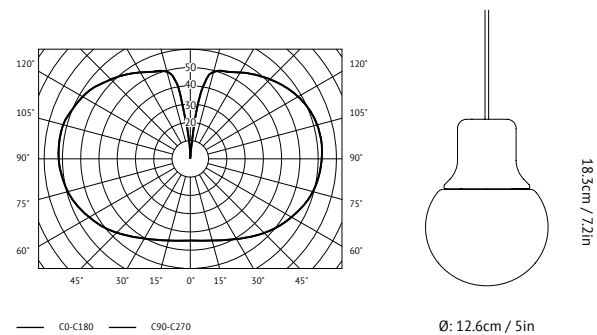

## MASS LIGHT NA6

BY NORM.ARCHITECTS  
2012

**Product category** Chandelier  
**Materials** Copper or brass, white acid-etched opal glass, 4-meter black fabric cord.  
**Dimensions (cm/in)** Ø: 12.6cm/5in, H: 18.3cm/7.2in, L: Min 80cm/31.5in Max 175cm/68.9in. W: 40cm/15.7in. Base: 16cm.  
**Light source** 1 x G9 – max 40 Watt.  
**Lamps included** G9 Max 40 Watt. The luminaire is compatible with bulbs of the energy classes: B - E. Bulb is not included.

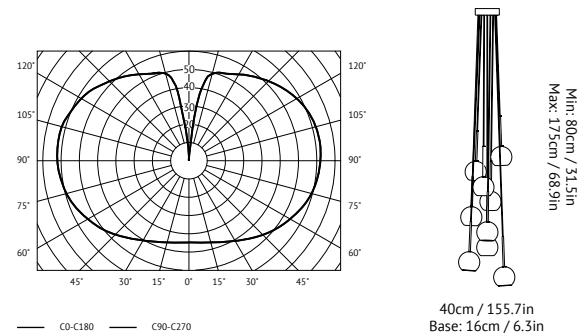

## BULB SR1

BY SOFIE REFER  
2001

**Product category** Pendant  
**Materials** Mouth blown glass with 3-meter cord and porcelain lamp holder.  
**Dimensions (cm/in)** Ø: 11cm/4.3in, H: 16.3cm/6.4in.  
**Colours** Clear glass with clear PVC cord, Clear glass with black fabric cord.  
**Light source** E27 Max 60 Watt. The luminaire is compatible with bulbs of the energy classes: A++ - E. Bulb is not included.

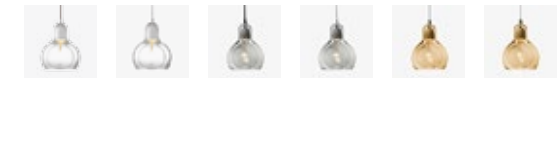
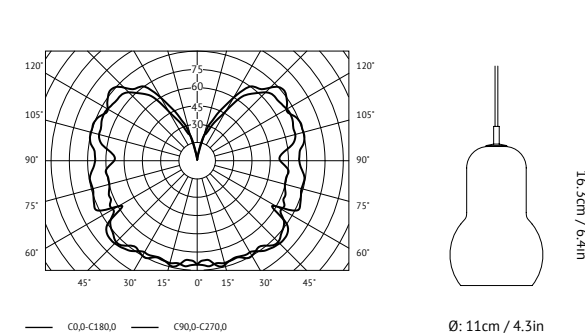

## MEGA BULB SR2

BY SOFIE REFER  
2006

**Product category** Pendant  
**Materials** Mouth blown glass with 3-meter cord and porcelain lamp holder.  
**Dimensions (cm/in)** Ø: 18cm/7.1in, H: 23cm/9in.  
**Colours** Clear glass with black fabric cord, Clear glass with clear cord, Silver lustre glass with black fabric cord, Silver lustre glass with clear PVC cord, Gold lustre glass with white fabric cord, Gold lustre glass with clear PVC cord.  
**Light source** E27 Max 60 Watt. The luminaire is compatible with bulbs of the energy classes: A++ - E. Bulb is not included.

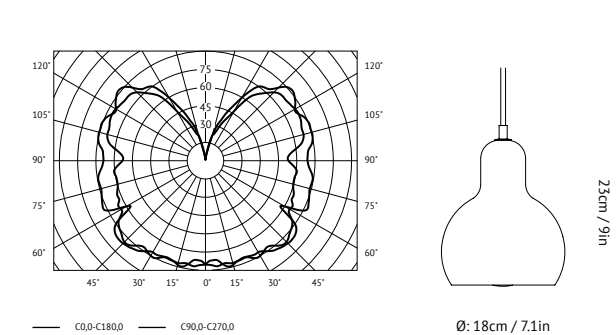

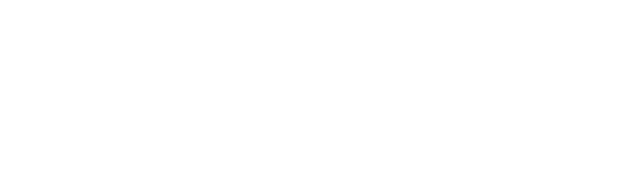
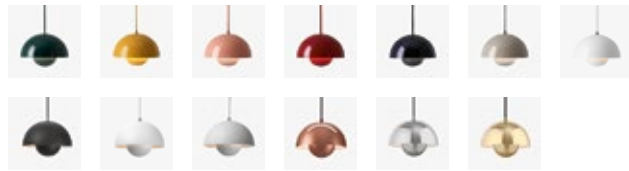

## FLOWERPOT VP1

BY VERNER PANTON  
1968

**Product category** Pendant  
**Materials** Lacquered metal with 3-meter fabric cord.  
**Dimensions (cm/in)** Ø: 23cm/9.1in, H: 16cm/6.3in.  
**Colours** Dark green, Mustard, Beige red, Deep red, Black blue, Grey beige, White, Matt black, Matt white, Matt grey, Polished copper, Polished stainless steel, Polished brass.  
**Light source** E27 Max 40 Watt. The luminaire is compatible with bulbs of the energy classes: A++ - E. Bulb is not included.

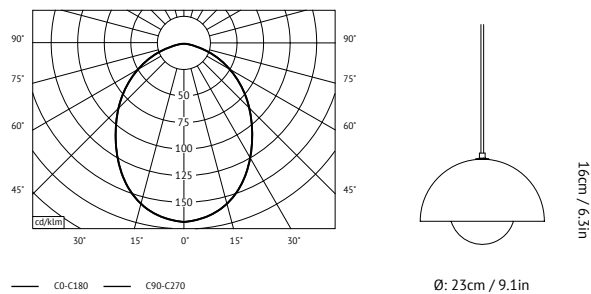

## FLOWERPOT VP2

BY VERNER PANTON  
1968

**Product category** Pendant  
**Materials** Lacquered metal with 3-meter fabric cord.  
**Dimensions (cm/in)** Ø: 50cm/19.7in, H: 36cm/14.2in.  
**Colours** White, other colours upon request.  
**Light source** E27 Max 60 Watt. The luminaire is compatible with bulbs of the energy classes: A++ - E. Bulb is not included.

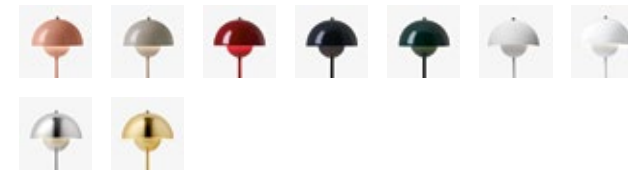
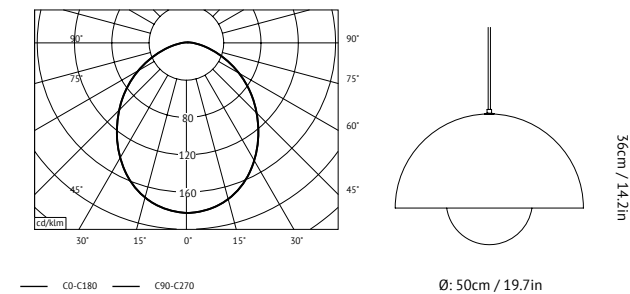

## FLOWERPOT VP3

BY VERNER PANTON  
1969

**Product category** Table lamp  
**Materials** Lacquered steel with 2-meter clear PVC cord.  
**Cord Dimensions** Ø: 23cm/9.1in, H: 50cm/19.7in.  
**Colours** Beige red, Grey beige, Deep red, Black blue, Dark green, Matt Grey, White, Polished stainless steel, Polished brass.  
**Light source** E27 Max 40 Watt. The luminaire is compatible with bulbs of the energy classes: A++ - E. Bulb is not included.

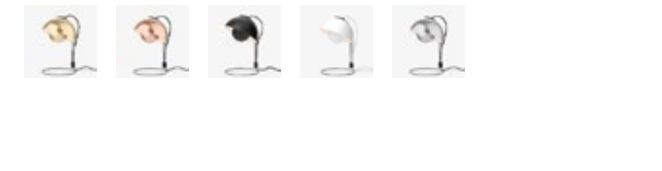
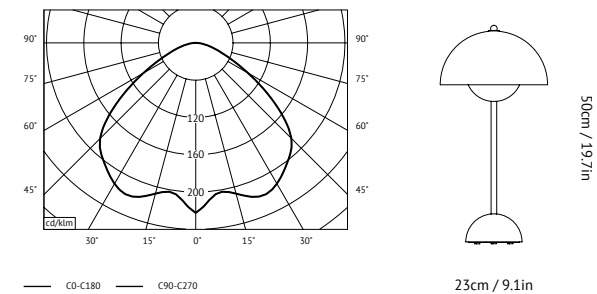

## FLOWERPOT VP4

BY VERNER PANTON  
1968

**Product category** Table lamp  
**Materials** Lacquered metal with 3-meter fabric cord.  
**Dimensions (cm/in)** Ø: 23cm/9.1in, H: 36cm/14.1in.  
**Colours** Polished brass, Polished copper, Matt black, Matt white, Polished stainless steel.  
**Light source** E 27 Max 40 Watt. The luminaire is compatible with bulbs of the energy classes: A++ - E. Bulb is not included.

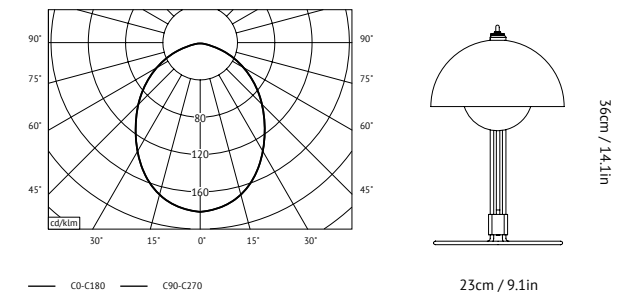

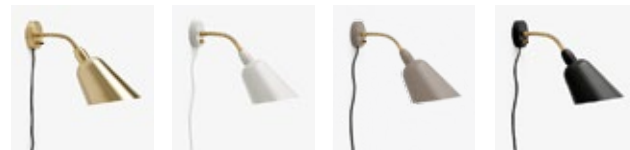

## BELLEVUE FLOOR AJ7

BY ARNE JACOBSEN  
1929

- Product category** Floor lamp
- Materials** Satin polished brass or satin polished brass with lacquered aluminium and steel, cast iron base, 2-meter fabric cord with on-off switch.
- Dimensions (cm/in)** Base: Ø: 27.3cm/10.7in. Lamp: D: 60cm/23.6in, H: 130cm/51.2in.
- Colours** Brass, Ivory white & brass, Grey beige & brass, Black & brass.
- Light source** E27 Max 60 Watt. The luminaire is compatible with bulbs of the energy classes: A++ - E. Bulb is not included.

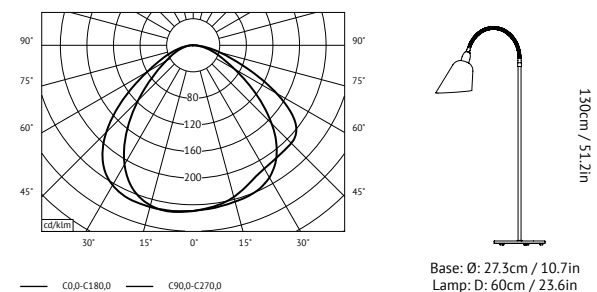

## BELLEVUE WALL AJ9

BY ARNE JACOBSEN  
1929

- Product category** Wall lamp
- Materials** Satin polished brass or satin polished brass with lacquered aluminium and steel, 2-meter fabric cord. On-off switch on wall mount base.
- Dimensions (cm/in)** Wall Mount: Ø: 8.5cm/3.3in. Lamp: D: 28cm/11in, W: 16.5cm/6.5in, H: 30cm/11.8in.
- Colours** Brass, Ivory white & brass, Grey beige & brass, Black & brass.
- Light source** E14 Max 40 Watt. The luminaire is compatible with bulbs of the energy classes: A++ - E. Bulb is not included.

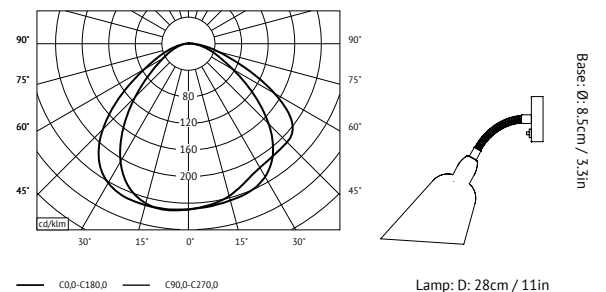

## BELLEVUE TABLE AJ8

BY ARNE JACOBSEN  
1929

- Product category** Table lamp
- Materials** Satin polished brass or satin polished brass with lacquered aluminium and steel, cast iron base, 2-meter fabric cord. On-off switch on base.
- Dimensions (cm/in)** Base: Ø: 17.5cm/6.9in. Lamp: D: 42cm/16.5in, W: 16.5cm/6.5in, H: 42cm/16.5in.
- Colours** Brass, Ivory white & brass, Grey beige & brass, Black & brass.
- Light source** E14 Max 40 Watt. The luminaire is compatible with bulbs of the energy classes: A++ - E. Bulb is not included.

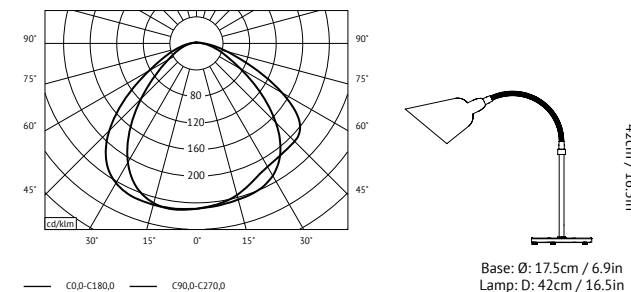

## BELLEVUE PLUG-IN TABLE LAMP AJ10 & AJ11

BY ARNE JACOBSEN  
1929

- Product category** Plug-in table lamp
- Materials** Satin polished brass or satin polished brass with lacquered aluminium and steel, cast iron base, 2-meter fabric cord. On-off switch on base.
- Dimensions (cm/in)** AJ10: Base plate: Ø: 7cm/2.83in. Lamp: D: 42cm/16.5in, W: 16.5cm/6.5in, H: 42cm/16.5in. AJ11: Base plate: Ø: 9.5cm/3.8in. Lamp: D: 42cm/16.5in, W: 16.5cm/6.5in, H: 42cm/16.5in.
- Colours** Brass, Ivory white & brass, Grey beige & brass, Black & brass.
- Light source** E14 Max 40 Watt. The luminaire is compatible with bulbs of the energy classes: A++ - E. Bulb is not included.

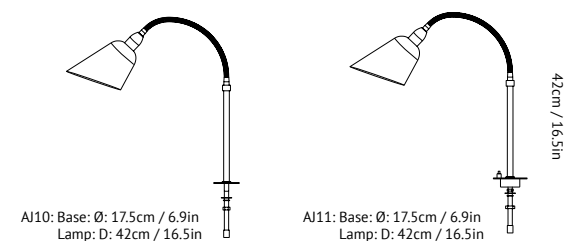





## TRASH ME VV1

BY VICTOR VETTERLEIN  
2010

**Product category** Table lamp  
**Materials** Paper pulp, 2-meter bordeaux fabric cord.  
**Dimensions (cm/in)** H: 52.4cm/20.6in, L: 25.4cm/10in, W: 16.5cm/6.5in.  
**Cord Colours** Natural paper bordeaux fabric colour.  
**Light Source:** E27 Max 40 Watt. The luminaire is compatible with bulbs of the energy classes: A++ - E. Bulb is not included.

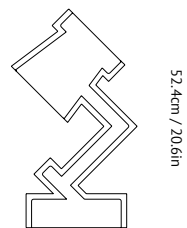
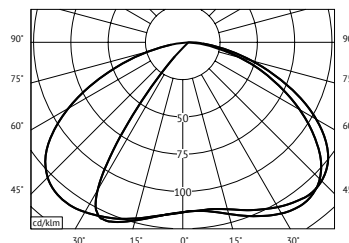

25.4cm / 10in x 16.5cm / 6.5in



**&tradition**  
Papirøen, Trangravsvej 24  
DK - 1436 Copenhagen K  
andtradition.com

©&tradition 2017

#andtradition

**CONCEPT / CREATIVE DIRECTION**  
All the Way to Paris

**ARTICLES**  
Julie Ralphs

**PHOTOGRAPHY**  
Irina Boersma & Peter Krasilnikoff  
Brian Buchard  
Mikkel Rahr Mortensen

**GRAPHIC DESIGN**  
All the Way to Paris

**PRINTED AT**  
Narayana Press

