

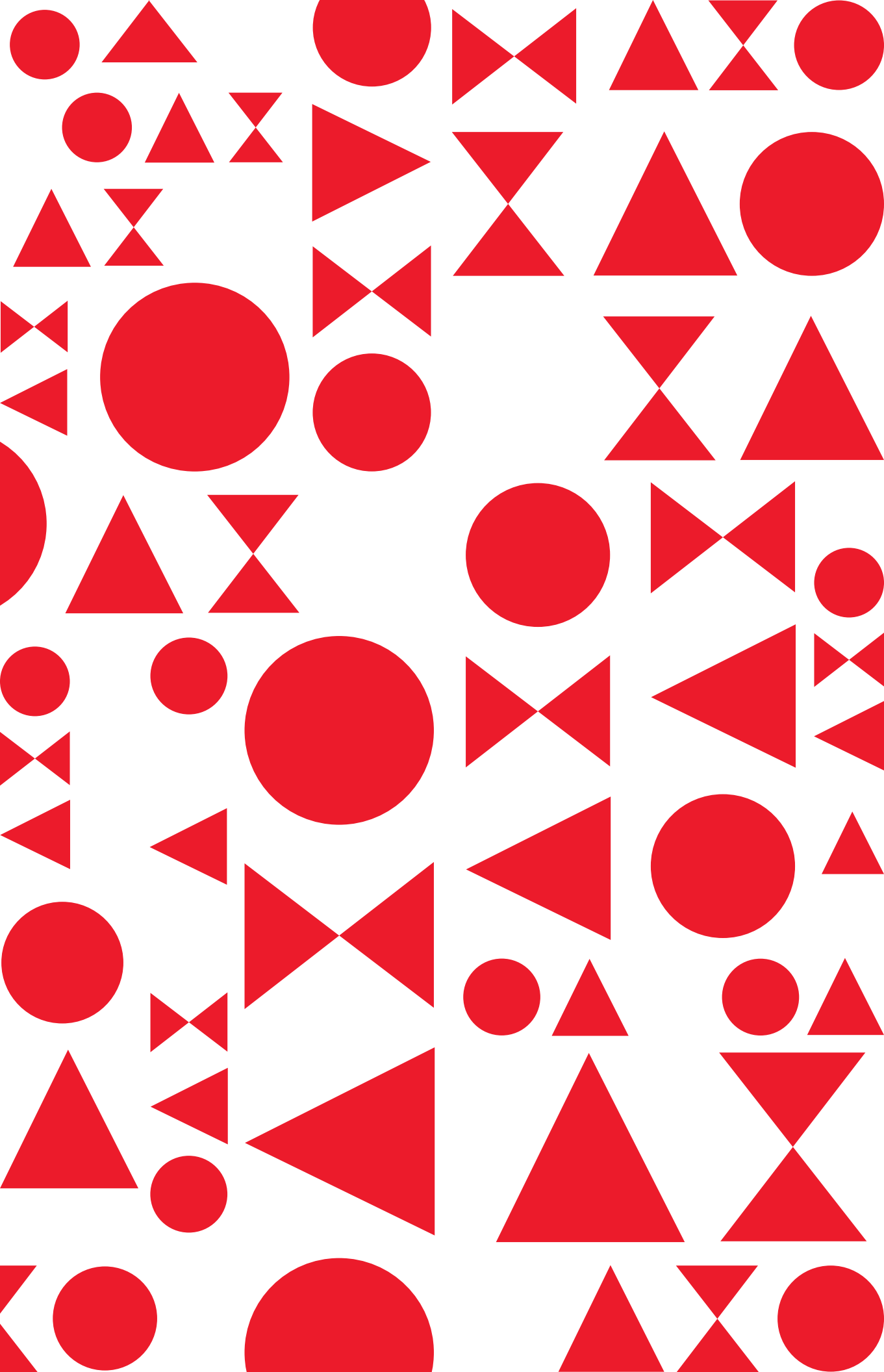

CATALOGUE

2017/18



Axolight bespoke
design

2017/18

**bespoke
design**

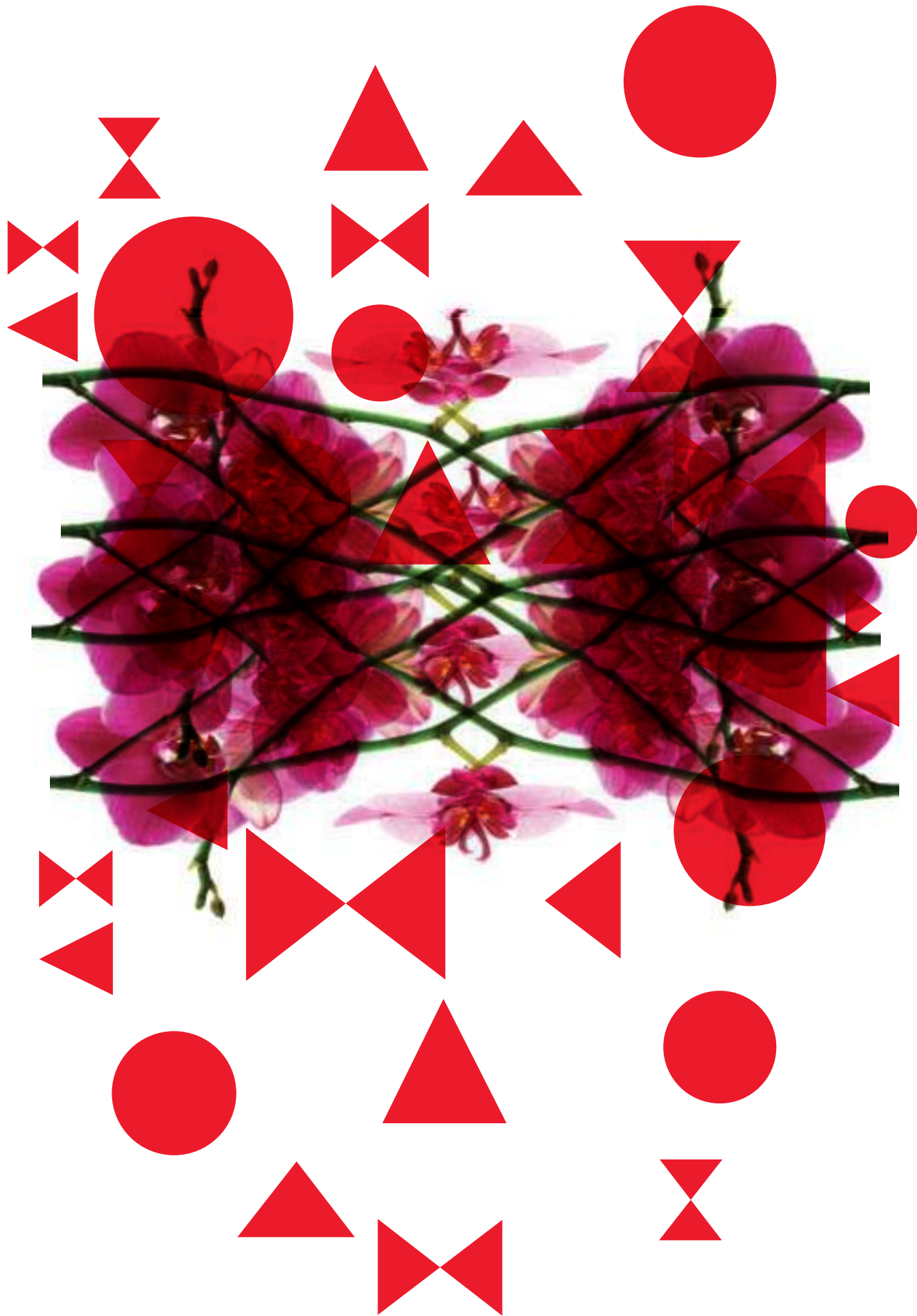

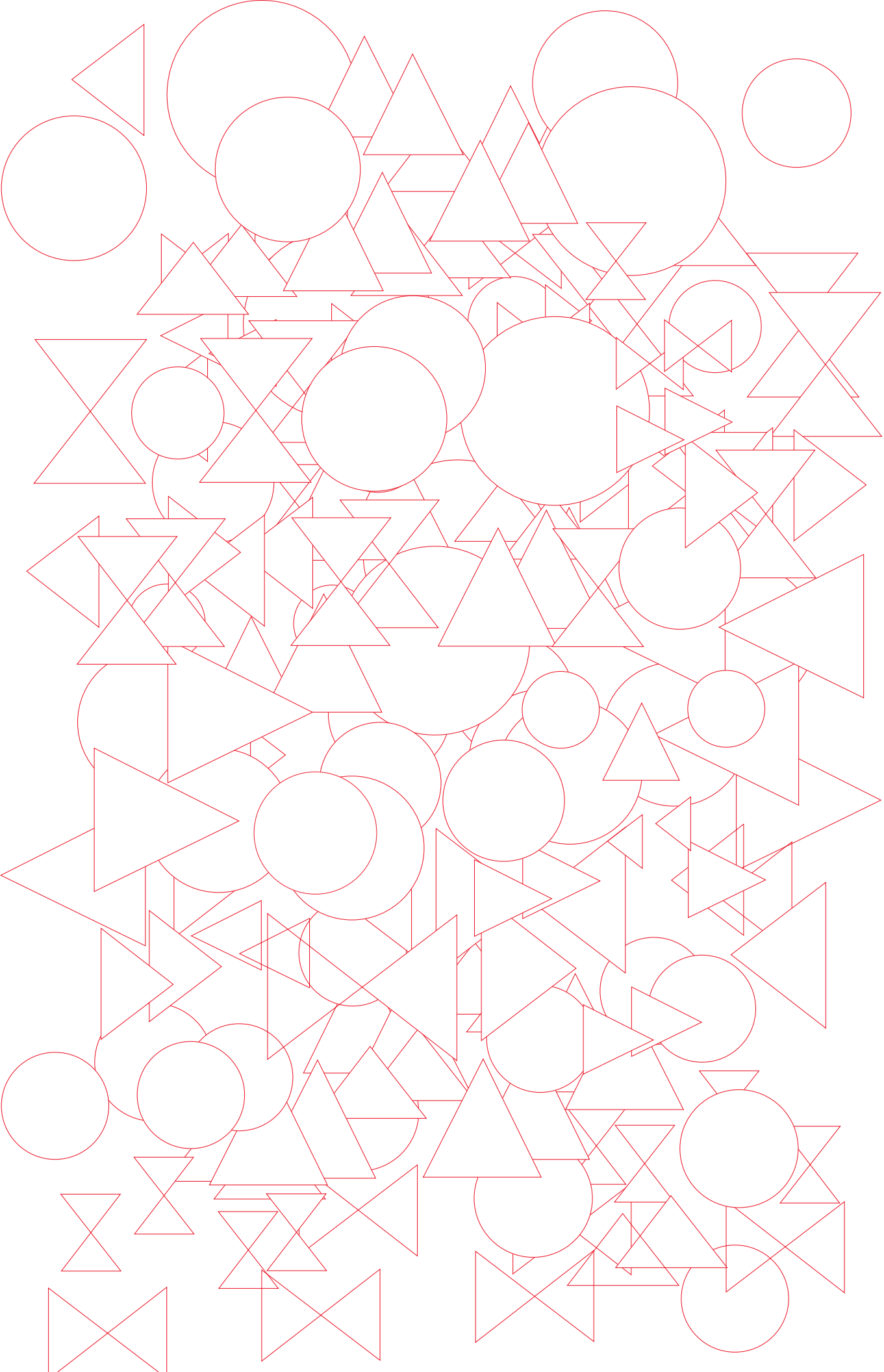

LIST OF PRODUCTS

SUSPENSION



Alrisha
6-7



Alysoid
8-11



Aura
12-13



Ax 20
14-15



Bell
16-19



Clavius
20-21



Explo
22-23



Fairy
24-27



Fedora
28-29



Hoops
30-31



Melting Pot
32-33



Mountain View
34-35



Muse
36-37



Nafir
38-39



Orchid
40-45



Rythmos
46-47



Skin
48-49



Skirt
50-53



Spillray
54-57



Spiry
58



Stilla
59



Urban
60-61



Urban Mini
62-63



Velvet
64-65



Virtus
66-67

WALL



Alrisha
70



Aura
71



Ax 20
72-73



Clavius
74-75



Fairy
76-77



Lik
78-79



Melting Pot
80-81



Momus Mini
82-83



Orchid
84-85



Polia LED
86-87



Rythmos
88



Shatter LED
89



Skirt
90-91



Spillray
92-93



U-light
94-95



Uriel
96-97



Vasily
98



Voluptas
99

WALL & CEILING



Ax 20
102-103



Favilla
104-105



Muse
106-107



Necky
108-109



Nelly
110



Nelly Straight
111



Orchid
112-113



Stormy
114-115



Ukiyo
116-117

CEILING



Aura
120-121



Bell
122-125



Clavius
126-127



Fairy
128



Hoops
129

RECESSED



Crystal Spotlight
168-169



Fairy
170-171



Favilla
172-173



Fedora
174-175



Nafir
176-177



Spillray
178-179



Nafir
130-131



Orchid
132-133



Skin
134



Skirt
135



Sol
136-137

LARGE SCALE



Urban
138-139



Urban Mini
140-141



Velvet
142



Voluptas
143



Anadem
182-183



Bell
184-191



Euler
192-193



Framework LED
194-197

TABLE



Aibu
146-147



Ax 20
148-149



Clavius
150-151



Muse
152-153



Skirt
154-155



Layers
198-199



Melting Pot
200-203



Plumage
204-205



Shatter LED
206-207



Skin
208-209



Skirt
210-213



U-light
214-225



Velvet
226-227

FLOOR



Ax 20
158-159



Clavius
160-161



Melting Pot
162-163



Orchid
164-165

BESPOKE

228



THE DESIGNERS

p. 1-3

SUSPENSION

p. 4-67

WALL

p. 68-99

WALL & CEILING

p. 100-117

CEILING

p. 118-143

TABLE

p. 144-155

FLOOR

p. 156-165

RECESSED

p. 166-179

LARGE SCALE

p. 180-227

BESPOKE

p. 228-239

GIOVANNI BARBATO
MANUEL BORRI/DIAGORA DESIGN
CAMBI SCATENA TURINI
SERGE & ROBERT CORNELISSEN
RYOSUKE FUKUSADA
DIMA LOGINOFF
RAINER MUTSCH
KARIM RASHID
BRIAN RASMUSSEN
TIMO RIPATTI
SANDRO SANTANTONIO
LORENZO TRUANT
MANUEL VIVIAN
VANESSA VIVIAN



GIOVANNI BARBATO

Giovanni Barbato was born in Padua in 1974. He attended the University of Architecture in Venice and took an Industrial Design class in Padua. In 2013, he designed the "Spiry" collection for Axo Light, which led him to win a "Good Design Award", one of the most coveted design prizes. In 2015, he designed the "Hoops" and "Aibu" collections for Axo Light.



**MANUEL BORRI
DIAGORA DESIGN**

Diagora Design studio deals with industrial & interior design, graphics, and project development with a particular focus on the research of innovative materials and the use of new productive technologies. Hidden behind the alias Diagora Design is the designer Manuel Borri, who is supported by a small team of young and dynamic professionals.



**CAMBI SCATENA
TURINI**

"Cambi, Scatena, Turini Architects" Studio is a design laboratory founded in 1998 with headquarters near Pisa, steps away from the Fortress of Brunelleschi. Since its establishment, the Studio is interested and involved in architecture, urban design, interior and industrial design.



**ROBERT & SERGE
CORNELISSEN**

The Serge Cornelissen design office was founded by architect Serge Cornelissen in 1993, and specializes exclusively in the design of architectural lighting product. The studio works for several trendsetting lighting companies worldwide. Cornelissen studio designs are regularly awarded at international design awards.



RYOSUKE FUKUSADA

Ryosuke Fukusada was born in 1979 in Osaka, Japan. He studied product design at the Kanazawa College of Art. He then worked for Sharp. After transferring to Italy, he graduated from the Domus Academy. In 2008, he worked for Studio Urquiola in Milan. He then started his own studio in 2012 in Kyoto, Japan. He currently works with some international clients



DIMA LOGINOFF

Best Designer of The Year (Elle Decoration Best of The Year Award 2014) award winner Dima Loginoff, has already designed 20 collections for world-famous international brands. One of his lamps, Mountain View, designed for Axo Light was awarded twice as Best Lighting in the USA (Best of the Year Award) and in Russia (Elle Decoration Best of The Year Award).



TIMO RIPATTI

Educated as a furniture designer and architect, Timo Ripatti leads Studio Ripatti in Helsinki. He is working mainly in the field of product design with clients across the Europe. His mission is to combine aesthetic, poetic, and functional qualities into his work while achieving a perfect balance with the space and architecture.



SANDRO SANTANTONIO

Sandro Santantonio Design handles architecture, interior and industrial design, graphics, packaging and fashion design, while focusing on tendencies research, material study, and new technologies about contract, fashion, and lighting design. Sandro Santantonio publicizes his research by publishing them in major international magazines.



RAINER MUTSCH

Rainer Mutsch studied Industrial Design at the University of Applied Arts in Vienna, Furniture Design at the Denmark Design School in Copenhagen and Product Design at the University of Arts in Berlin. He opened his own design studio in Vienna in 2008. His products have received several international design awards, such as the Red Dot Design Award.



KARIM RASHID

Karim Rashid is one of the most prolific designers of his generation. Over 4000 designs in production, over 300 awards, and working in over 35 countries attest to Karim's legend of design. His award winning designs include everyday objects, interiors, furniture, brand identity, high-tech products, and luxury goods.



BRIAN RASMUSSEN

Brian Rasmussen was born in Ringsted, Denmark in 1973. He graduated from the "Royal Academy of Architecture" in Copenhagen in 2000. In 2004, he won the international "TARGETTI LIGHT ART AWARD", which became the starting point for his career as a lighting designer. Now Brian Rasmussen works with many important design firms.



LORENZO TRUANT

Lorenzo Truant graduated in architecture in 2001. After obtaining his degree and a master in Product Design, he worked in the lighting design area. He has worked for over 10 years as an Art Director at Axo Light. He designs light exploring all the possible implications of LED and OLED technology.



MANUEL VIVIAN

Born in Venice in 1971, Manuel Vivian obtained his diploma at the Venice Art Institute and began to design at a very young age, focusing on blown glass in particular, thanks also to his family business. Since the creation of Axo Light in 1996, he has collaborated constantly with the company and has become one of the main designers



VANESSA VIVIAN

Vanessa Vivian was born in 1994 in Mirano, Venice. From a very young age she showed a keen eye, a strong passion and talent for design, particularly with glass and light. "Layers" and "Plumage" were designed by Vanessa.

suspension

- ALRISHA
- ALYSOID
- AURA
- AX 20
- BELL
- CLAVIUS
- EXPLO
- FAIRY
- FEDORA
- HOOPS
- MELTING POT
- MOUNTAIN VIEW
- MUSE
- NAFIR
- ORCHID
- RYTHMOS
- SKIN
- SKIRT
- SPILLRAY
- SPIRY
- STILLA
- URBAN
- URBAN MINI
- VELVET
- VIRTUS





ALRISHA
design Brian Rasmussen



[for more information see the technical guide at p. 4](#)



SUSPENSION

ALYSOID
design Ryosuke Fukusada



SUSPENSION

for more information see the technical guide at p. 5

ALYSOID
design Ryosuke Fukusada



[for more information see the technical guide at p. 5](#)



AURA
design Manuel Vivian

SUSPENSION



for more information see the technical guide at p. 8



SUSPENSION

AX 20
design Manuel Vivian



for more information see the technical guide at p. 10



BELL
design Manuel Vivian



SUSPENSION



SUSPENSION

[for more information see the technical guide at p. 12](#)

BELL
design Manuel Vivian



SUSPENSION



for more information see the technical guide at p. 12

CLAVIUS
design Manuel Vivian



[for more information see the technical guide at p. 14](#)



SUSPENSION

SUSPENSION



for more information see the technical guide at p. 20

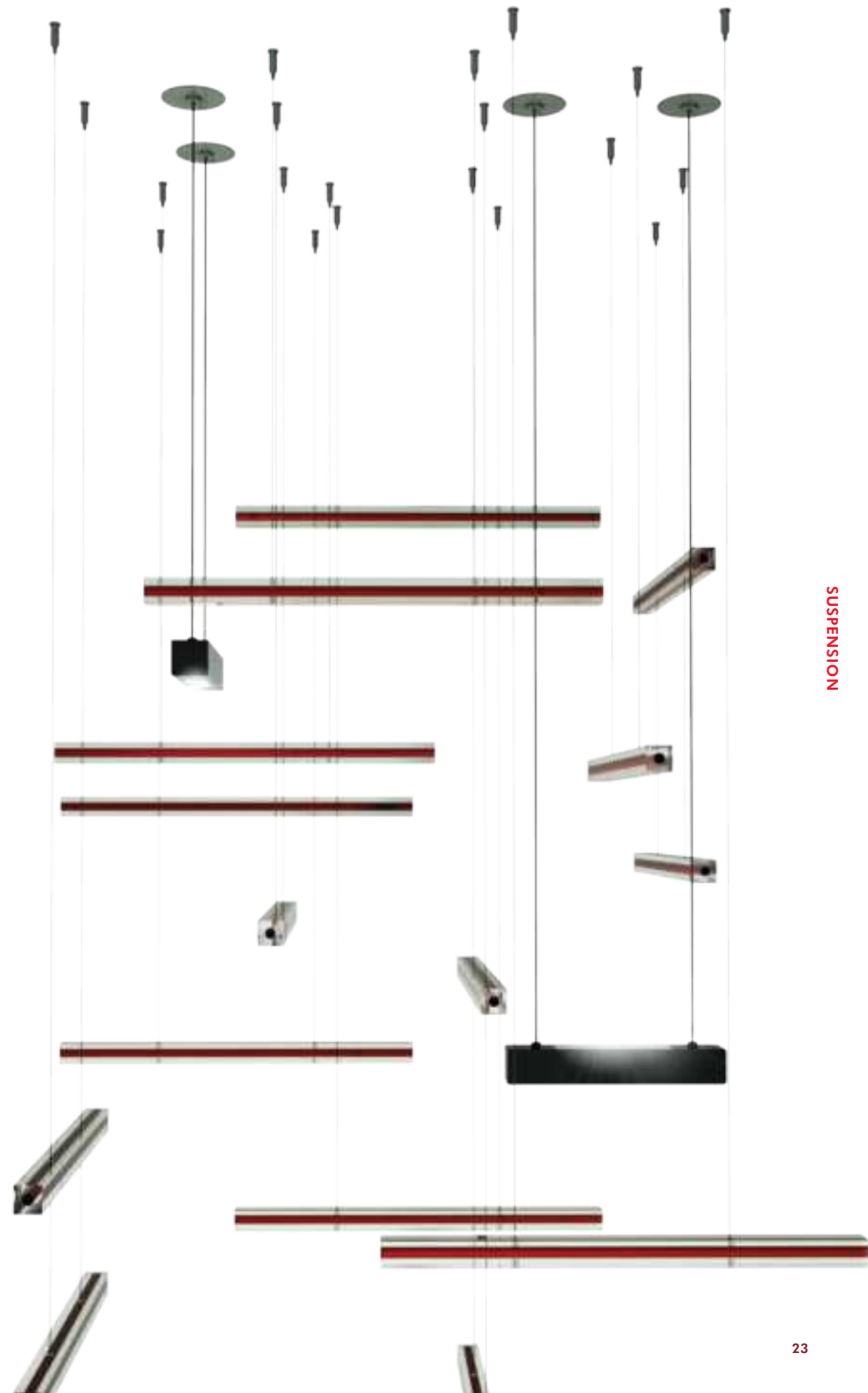

SUSPENSION

FAIRY
design Manuel Vivian



SUSPENSION



for more information see the technical guide at p. 23



FAIRY
design Manuel Vivian

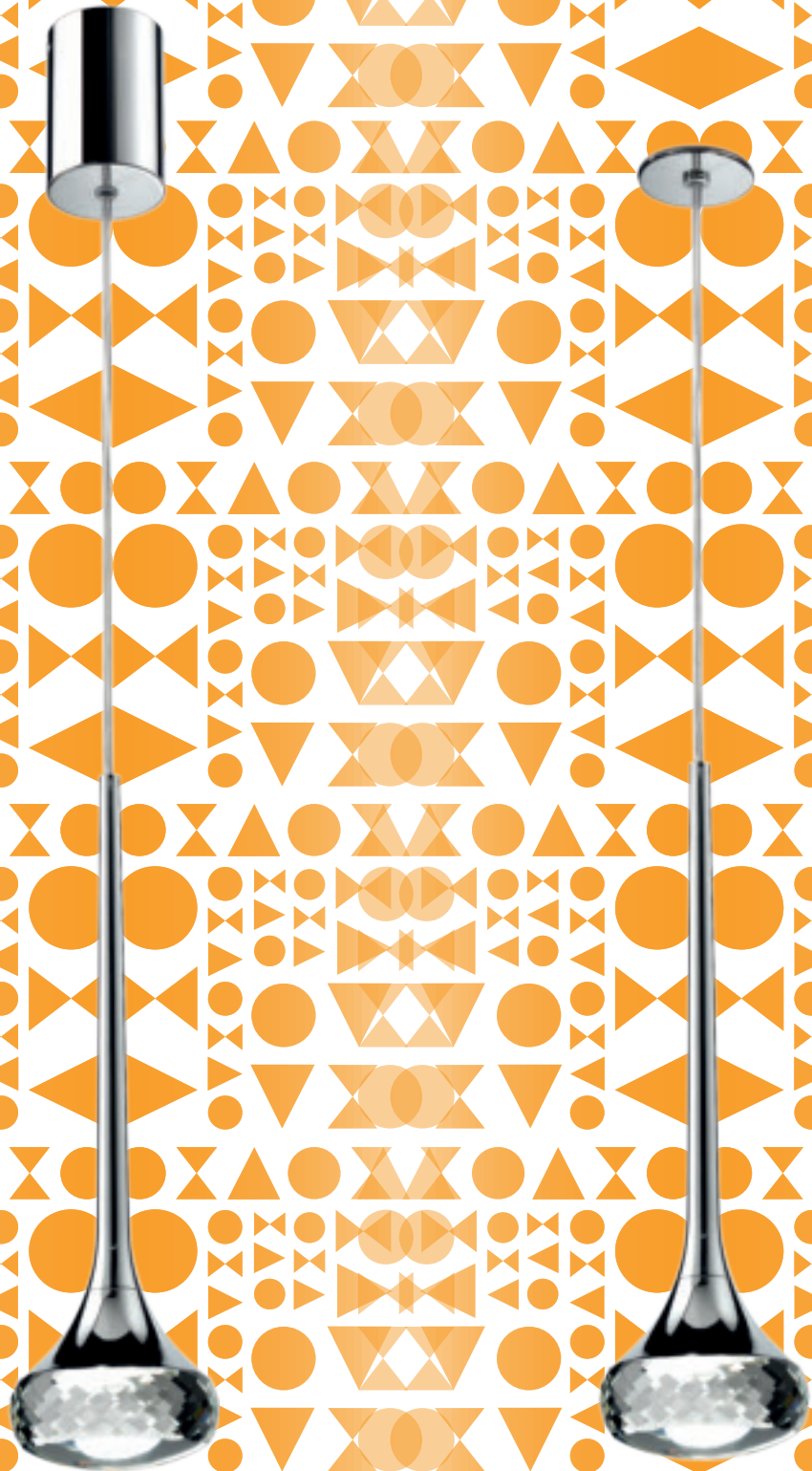

SUSPENSION



SUSPENSION

for more information see the technical guide at p. 23

FEDORA
design Dima Loginoff



SUSPENSION

for more information see the technical guide at p. 26

HOOPS
design Giovanni Barbato



SUSPENSION



SUSPENSION

[for more information see the technical guide at p. 30](#)



MELTING POT
design Sandro Santantonio



for more information see the technical guide at p. 34

MOUNTAIN VIEW
design Dima Loginoff

SUSPENSION



SUSPENSION

[for more information see the technical guide at p. 38](#)



MUSE

design Sandro Santantonio



SUSPENSION

[for more information see the technical guide at p. 41](#)

NAFIR
design Karim Rashid

SUSPENSION



SUSPENSION



[for more information see the technical guide at p. 42](#)

ORCHID
design Rainer Mutsch



SUSPENSION

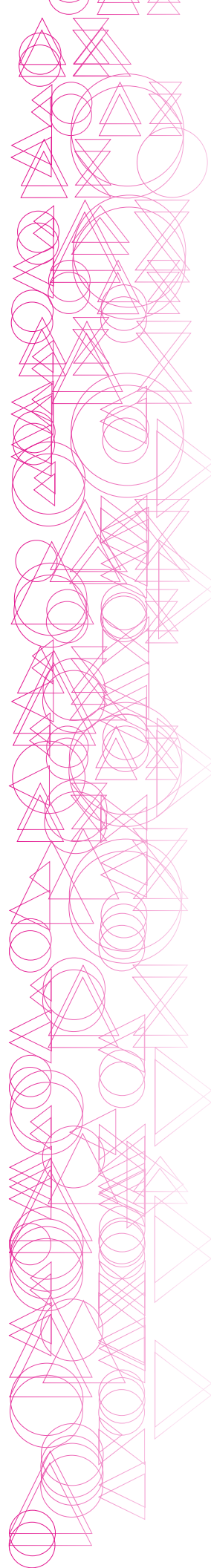

SUSPENSION

for more information see the technical guide at p. 45



ORCHID
design Rainer Mutsch



ORCHID
design Rainer Mutsch



SUSPENSION

for more information see the technical guide at p. 45

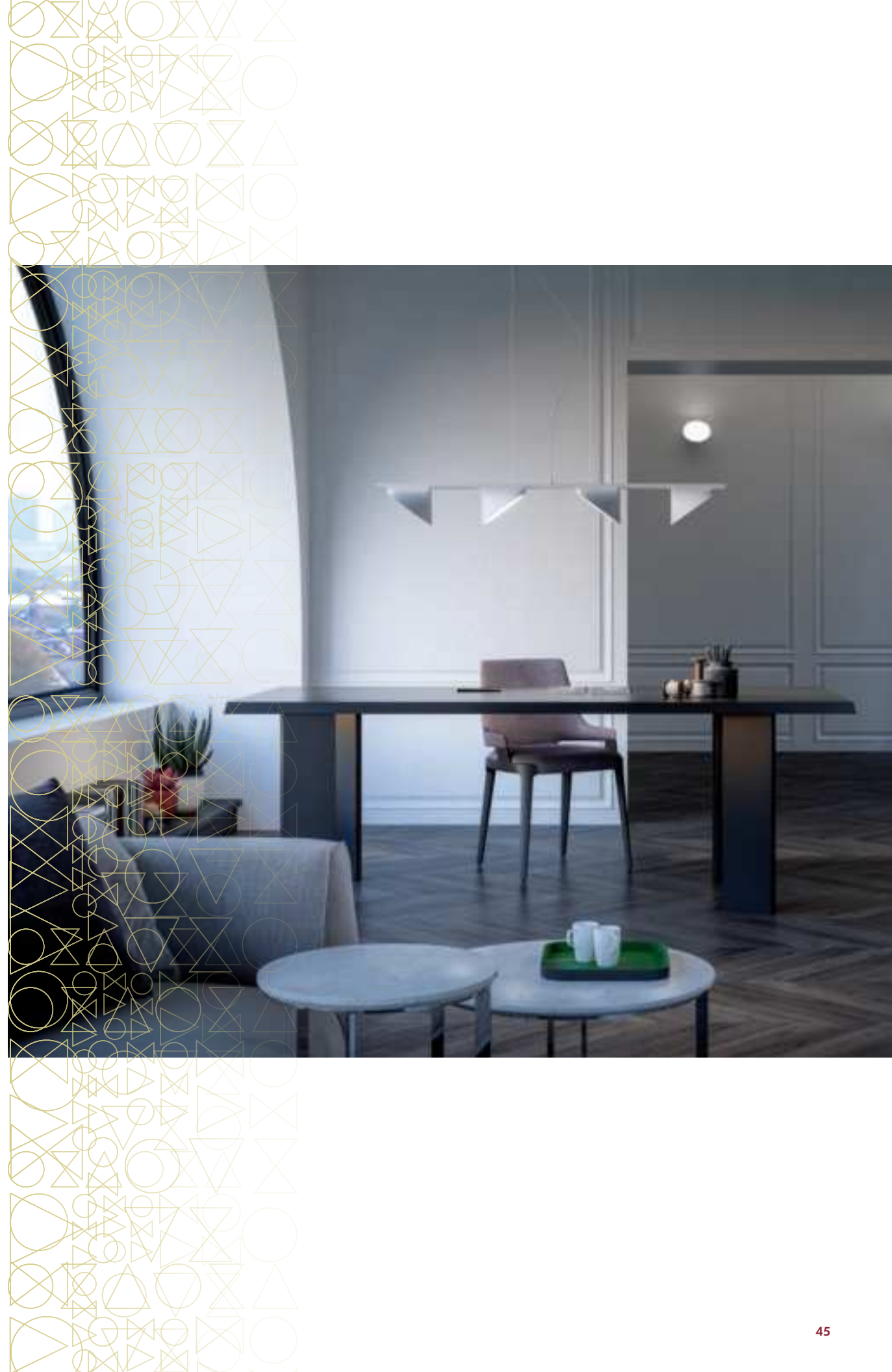



RYTHMOS
design Serge & Robert Cornelissen



for more information see the technical guide at p. 49

SKIN
design Manuel Vivian



for more information see the technical guide at p. 52

SKIRT
design Manuel Vivian

SUSPENSION



[for more information see the technical guide at p. 54](#)



SKIRT
design Manuel Vivian



SUSPENSION

[for more information see the technical guide at p. 54](#)

SPILLRAY
design Manuel Vivian



SUSPENSION

for more information see the technical guide at p. 58



SUSPENSION

SPILLRAY
design Manuel Vivian

SUSPENSION



for more information see the technical guide at p. 58



SUSPENSION

SPIRY
design Giovanni Barbato



SUSPENSION

for more information see the technical guide at p. 63

STILLA
design Manuel Vivian



SUSPENSION

for more information see the technical guide at p. 63



SUSPENSION

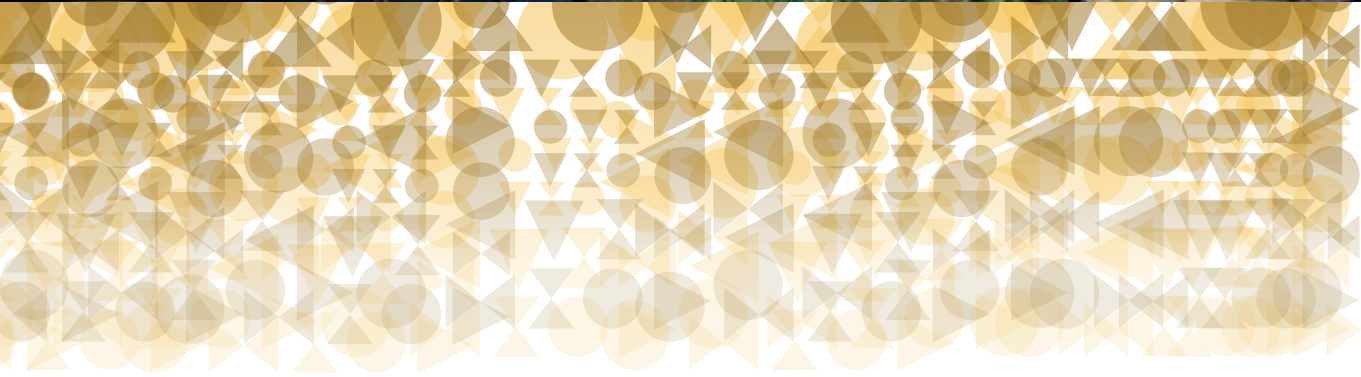

URBAN
design Dima Loginoff

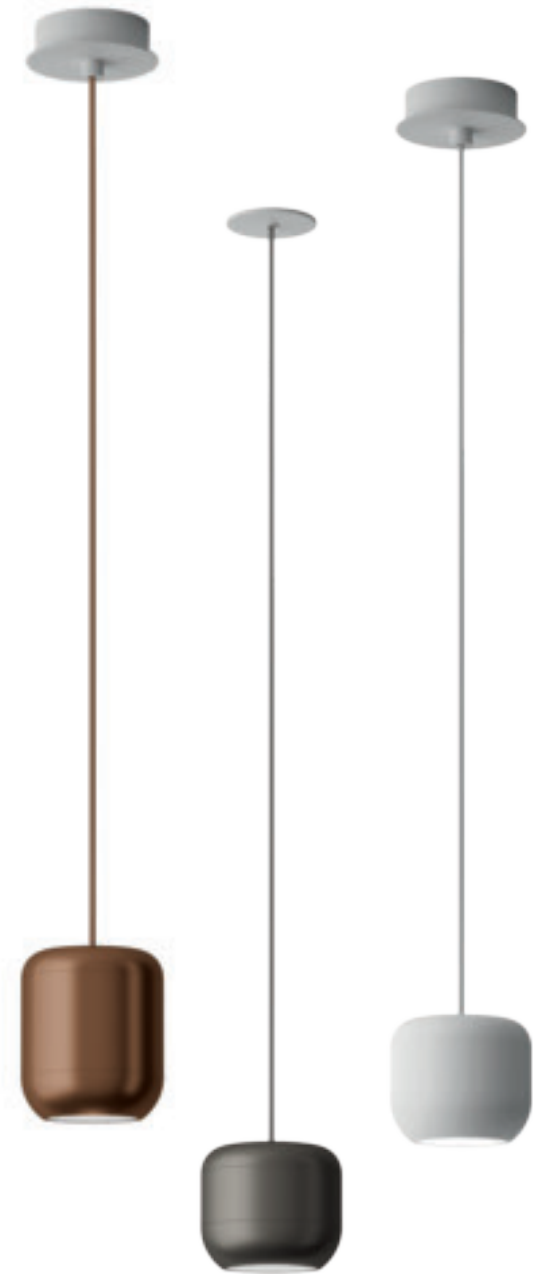

SUSPENSION

[for more information see the technical guide at p. 70](#)

URBAN MINI
design Dima Loginoff

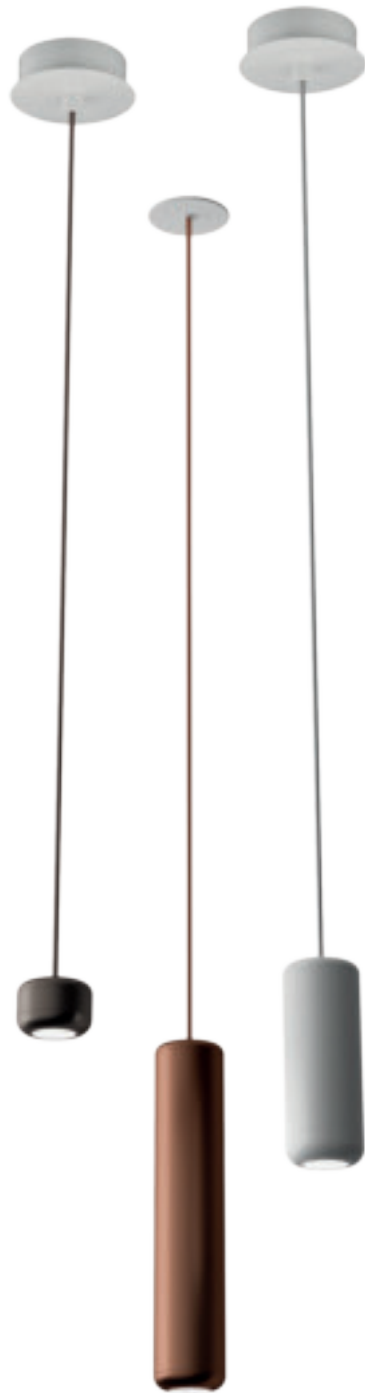

SUSPENSION

[for more information see the technical guide at p. 72](#)



VELVET
design Manuel Vivian



[for more information see the technical guide at p. 76](#)

VIRTUS
design Manuel Vivian



SUSPENSION

for more information see the technical guide at p. 77



SUSPENSION

wall

- ALRISHA
- AURA
- AX 20
- CLAVIUS
- FAIRY
- LIK
- MELTING POT
- MOMUS MINI
- ORCHID
- POLIA LED
- RYTHMOS
- SHATTER LED
- SKIRT
- SPILLRAY
- U-LIGHT
- URIEL
- VASILY
- VOLUPTAS



ALRISHA
design Brian Rasmussen



[for more information see the technical guide at p. 4](#)

AURA
design Manuel Vivian



[for more information see the technical guide at p. 7](#)



WALL

WALL



CLAVIUS
design Manuel Vivian



WALL

WALL

[for more information see the technical guide at p. 13](#)

FAIRY
design Manuel Vivian



for more information see the technical guide at p. 22

LIK
design Serge & Robert Cornelissen



for more information see the technical guide at p. 34

MELTING POT
design Sandro Santantonio



WALL

[for more information see the technical guide at p. 34](#)

MOMUS MINI
design Manuel Vivian

WALL



for more information see the technical guide at p. 38

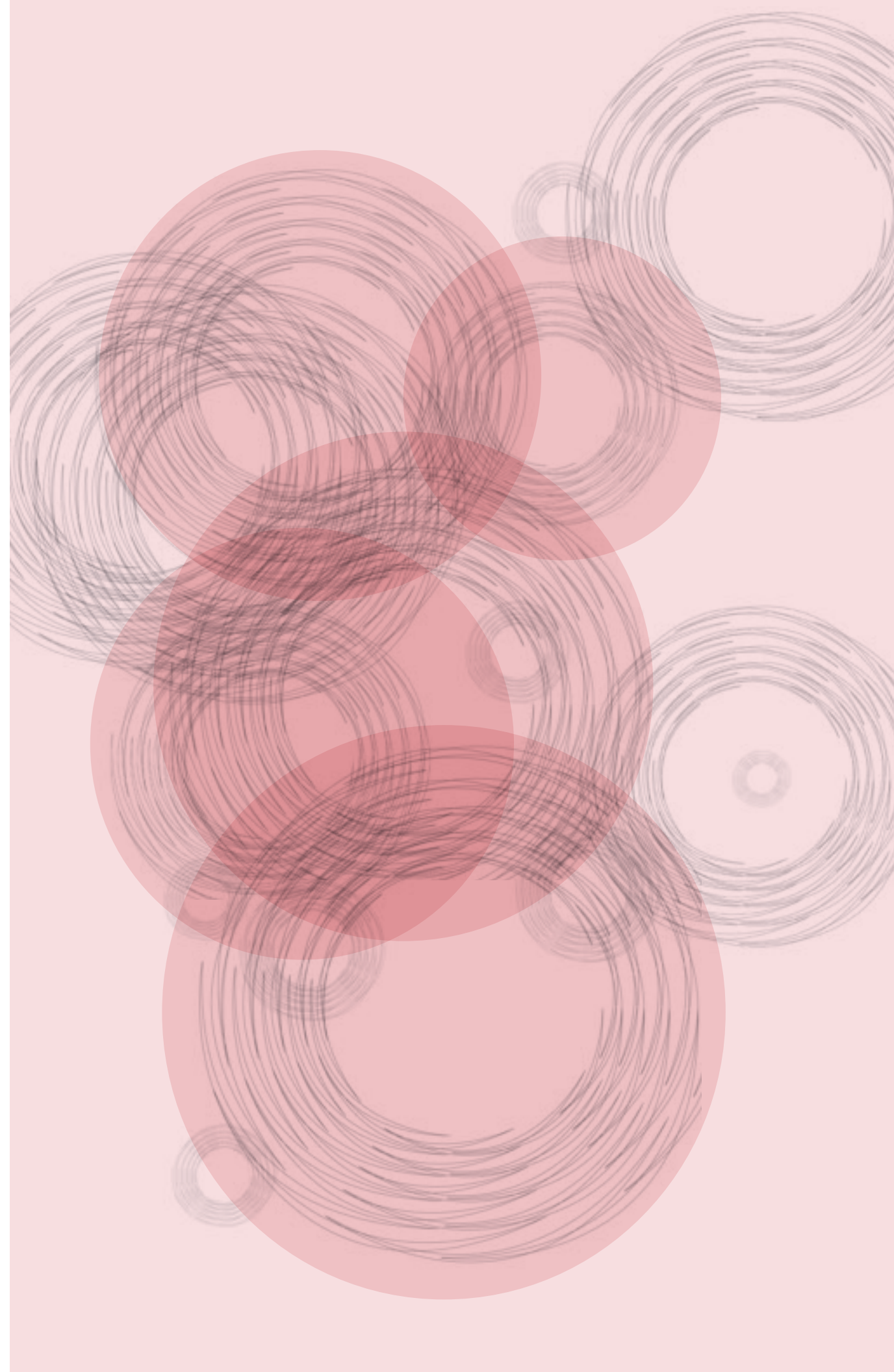

ORCHID
design Rainer Mutsch



WALL

WALL



[for more information see the technical guide at p. 44](#)

POLIA LED
design Manuel Vivian



WALL

[for more information see the technical guide at p. 48](#)

RYTHMOS

design Serge & Robert Cornelissen

WALL



[for more information see the technical guide at p. 48](#)

SHATTER LED

design Serge & Robert Cornelissen

WALL



[for more information see the technical guide at p. 49](#)

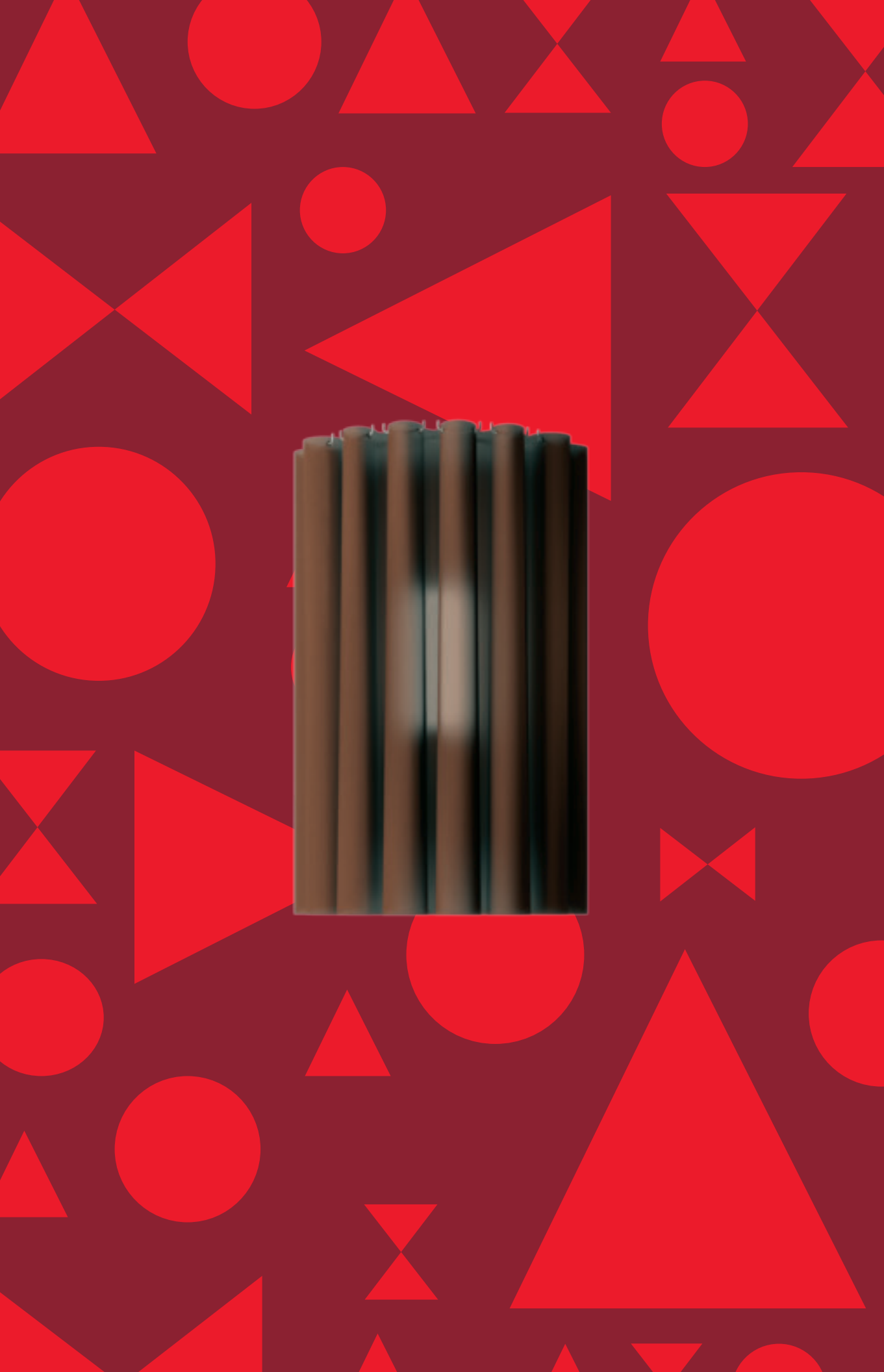

SKIRT
design Manuel Vivian



WALL

[for more information see the technical guide at p. 53](#)

SPILLRAY
design Manuel Vivian



for more information see the technical guide at p. 57



WALL

WALL



U-LIGHT
design Timo Ripatti



[for more information see the technical guide at p. 65](#)

URIEL
design Manuel Vivian

WALL



[for more information see the technical guide at p. 74](#)

VASILY
design Manuel Vivian



for more information see the technical guide at p. 74

WALL

VOLUPTAS
design Lorenzo Truant

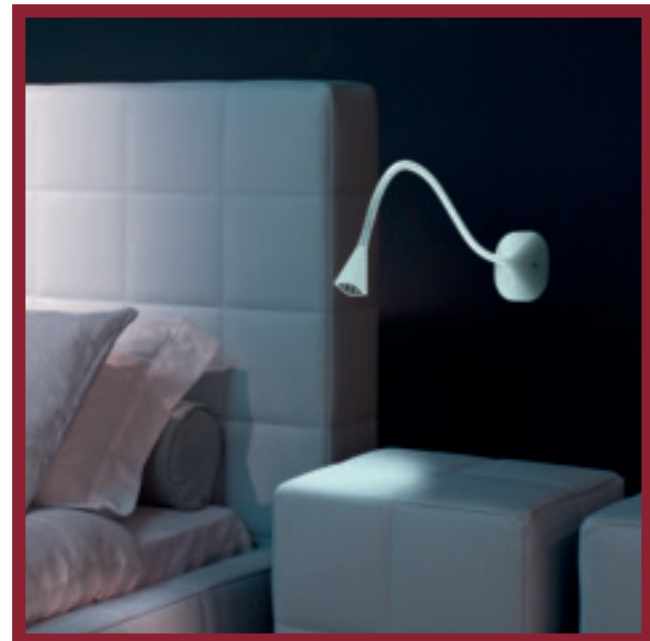

for more information see the technical guide at p. 78

WALL

wall/ceiling

- AX 20
- FAVILLA
- MUSE
- NECKY
- NELLY
- NELLY STRAIGHT
- ORCHID
- STORMY
- UKIYO

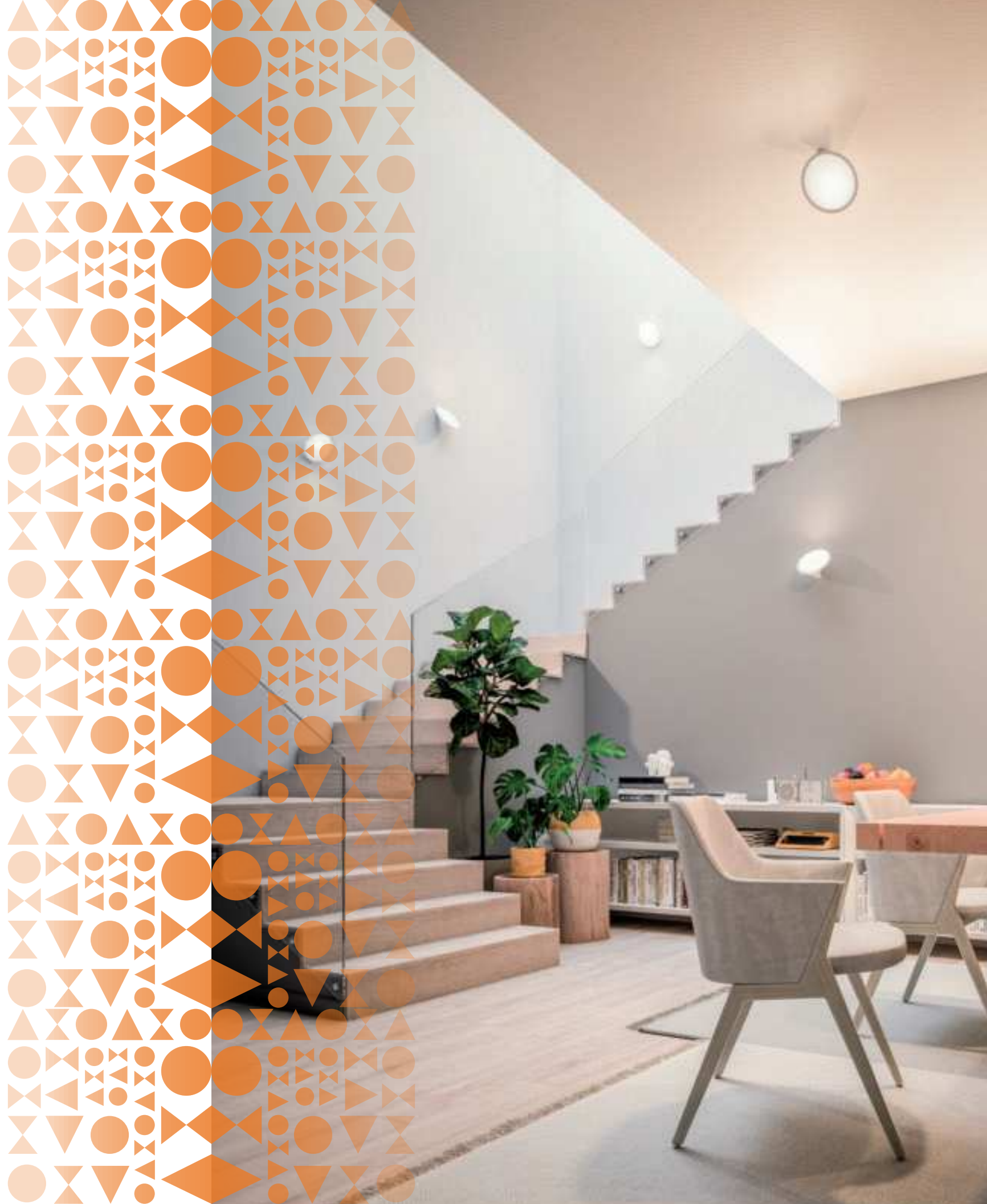

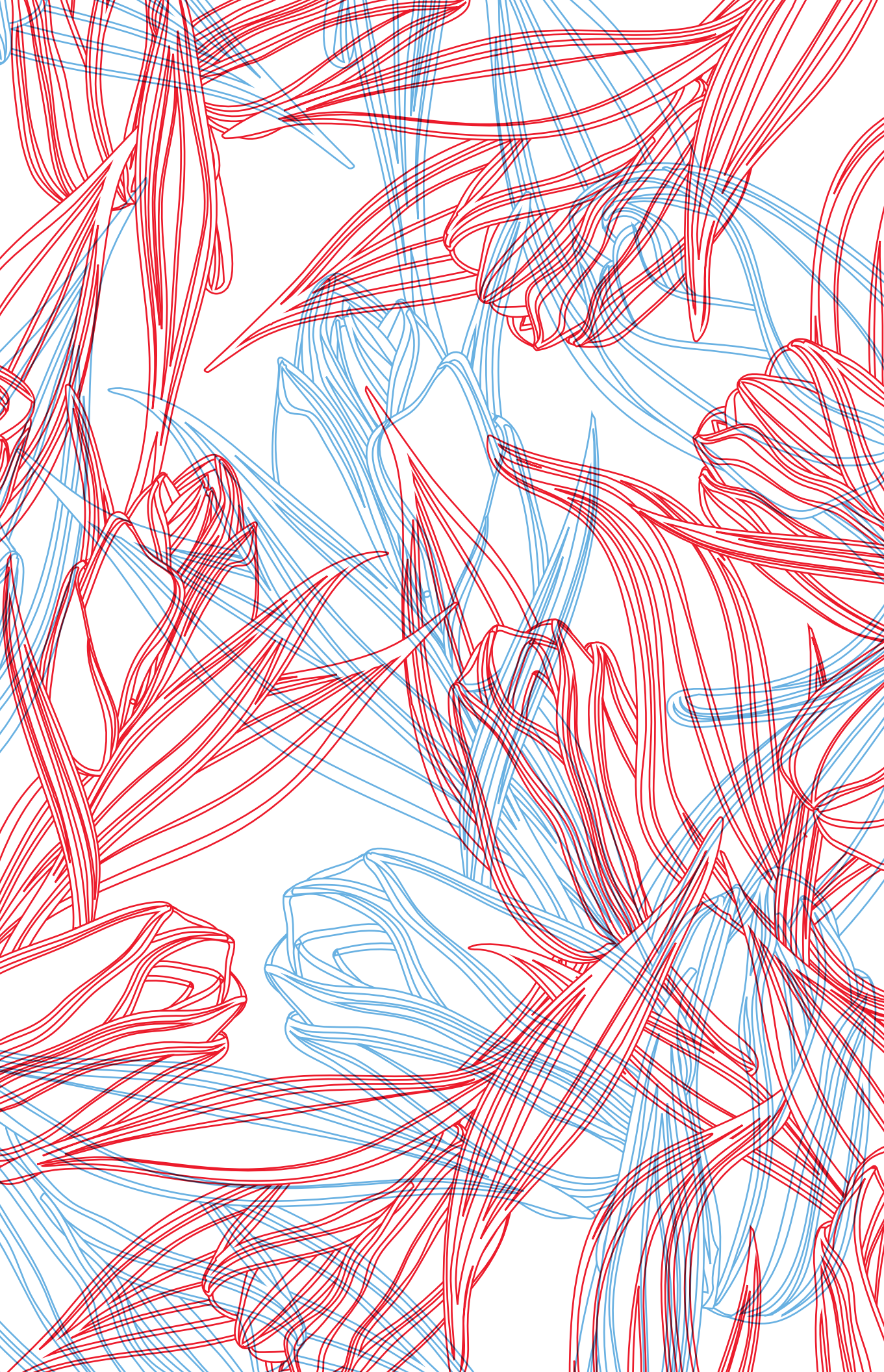

WALL/CEILING



WALL/CEILING

WALL/CEILING

MUSE
design Sandro Santantonio



WALL/CEILING

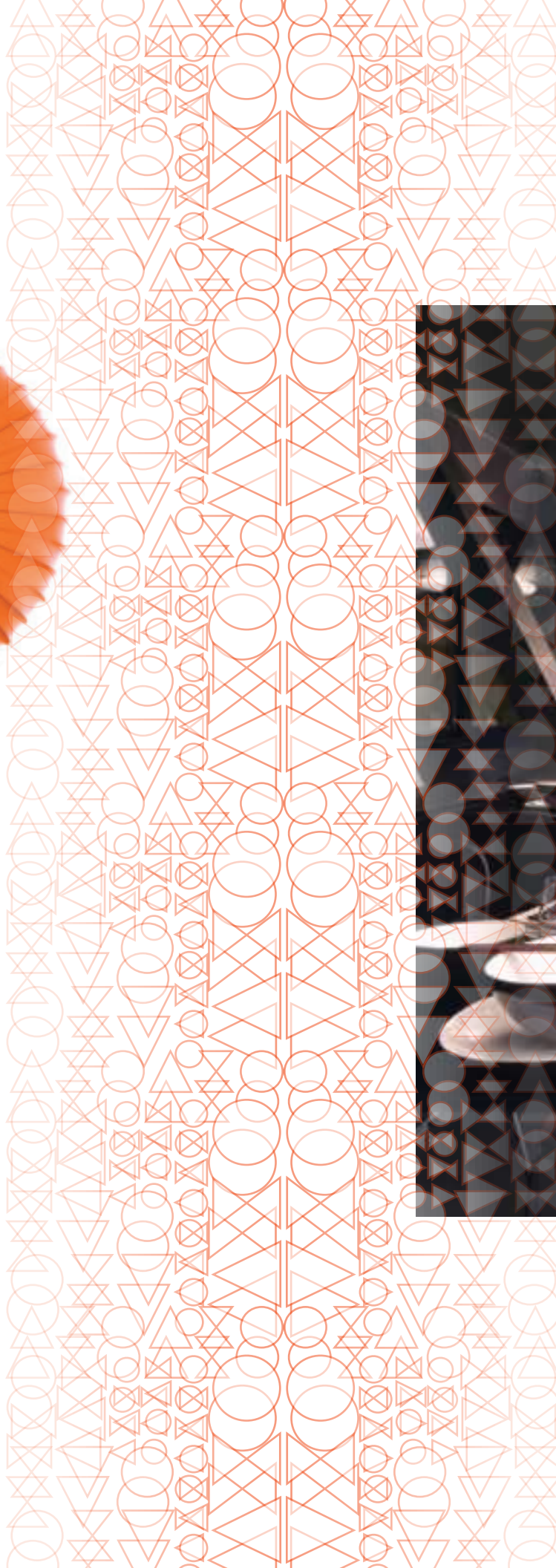

WALL/CEILING

for more information see the technical guide at p. 39

NECKY
design Diagora Design

WALL/CEILING

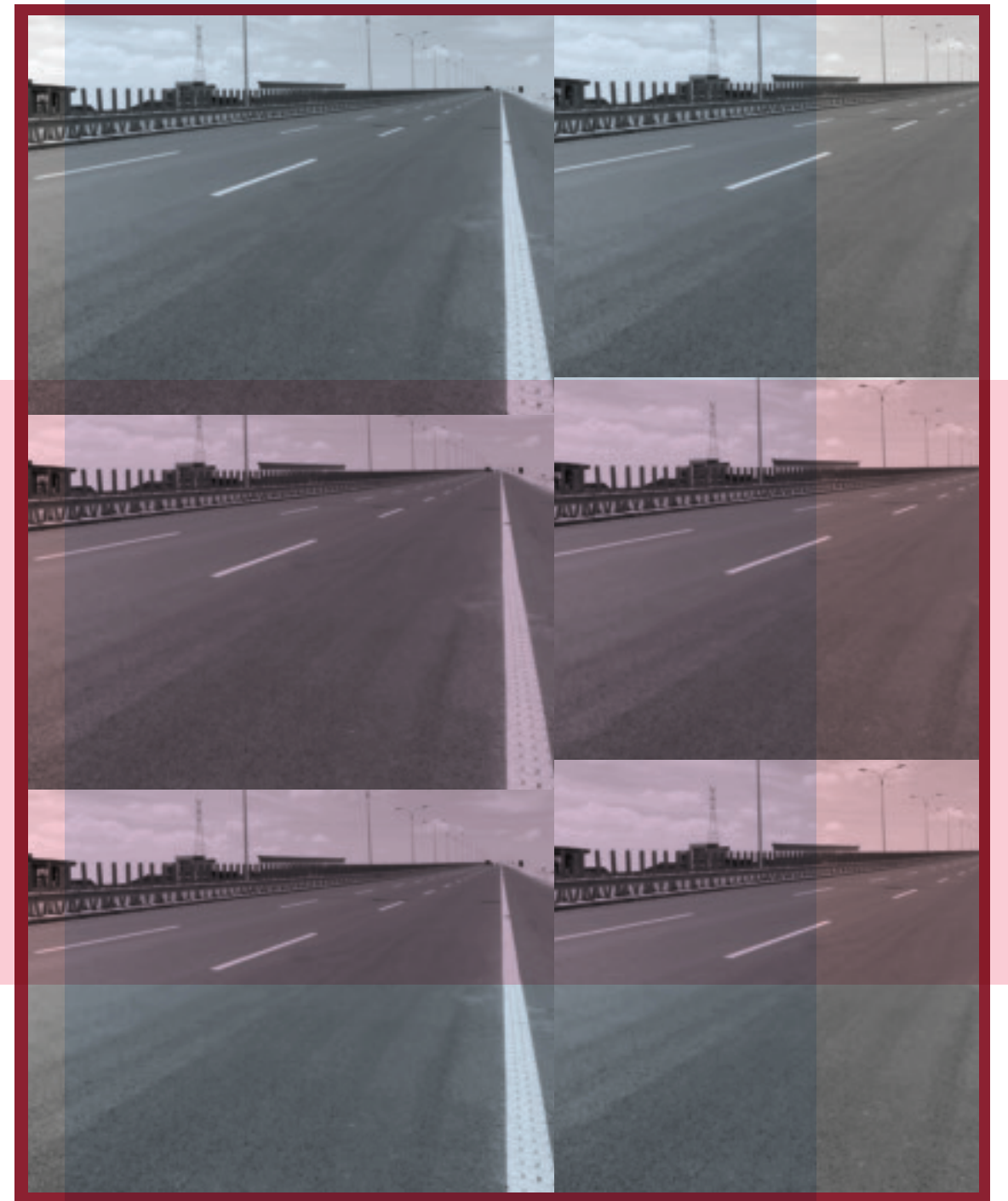

[for more information see the technical guide at p. 43](#)

NELLY
design Manuel Vivian



WALL/CEILING

for more information see the technical guide at p. 43

NELLY STRAIGHT
design Manuel Vivian



WALL/CEILING

for more information see the technical guide at p. 44

ORCHID
design Rainer Mutsch



WALL/CEILING

for more information see the technical guide at p. 44

STORMY
design Manuel Vivian



WALL/CEILING

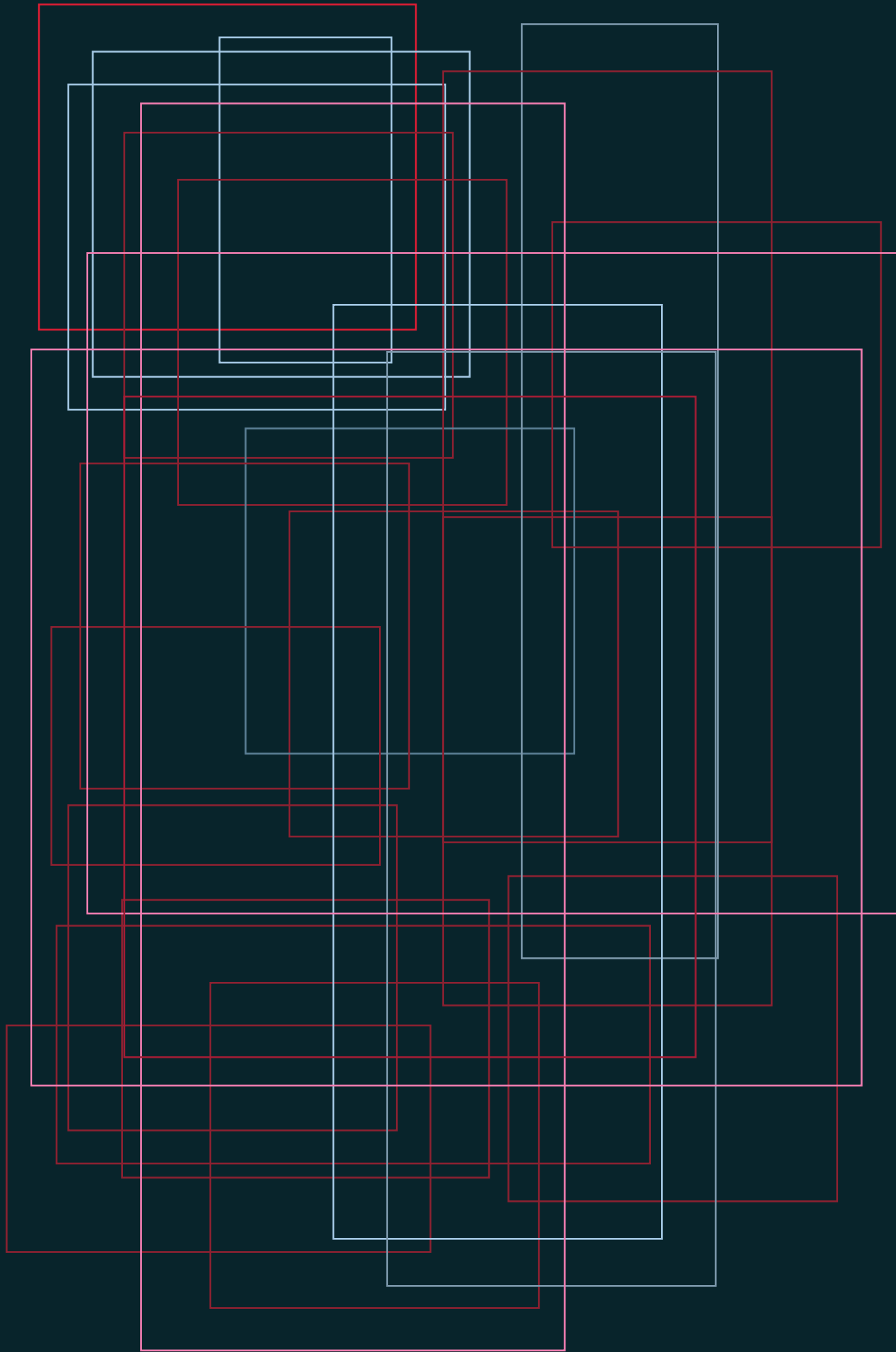

for more information see the technical guide at p. 64

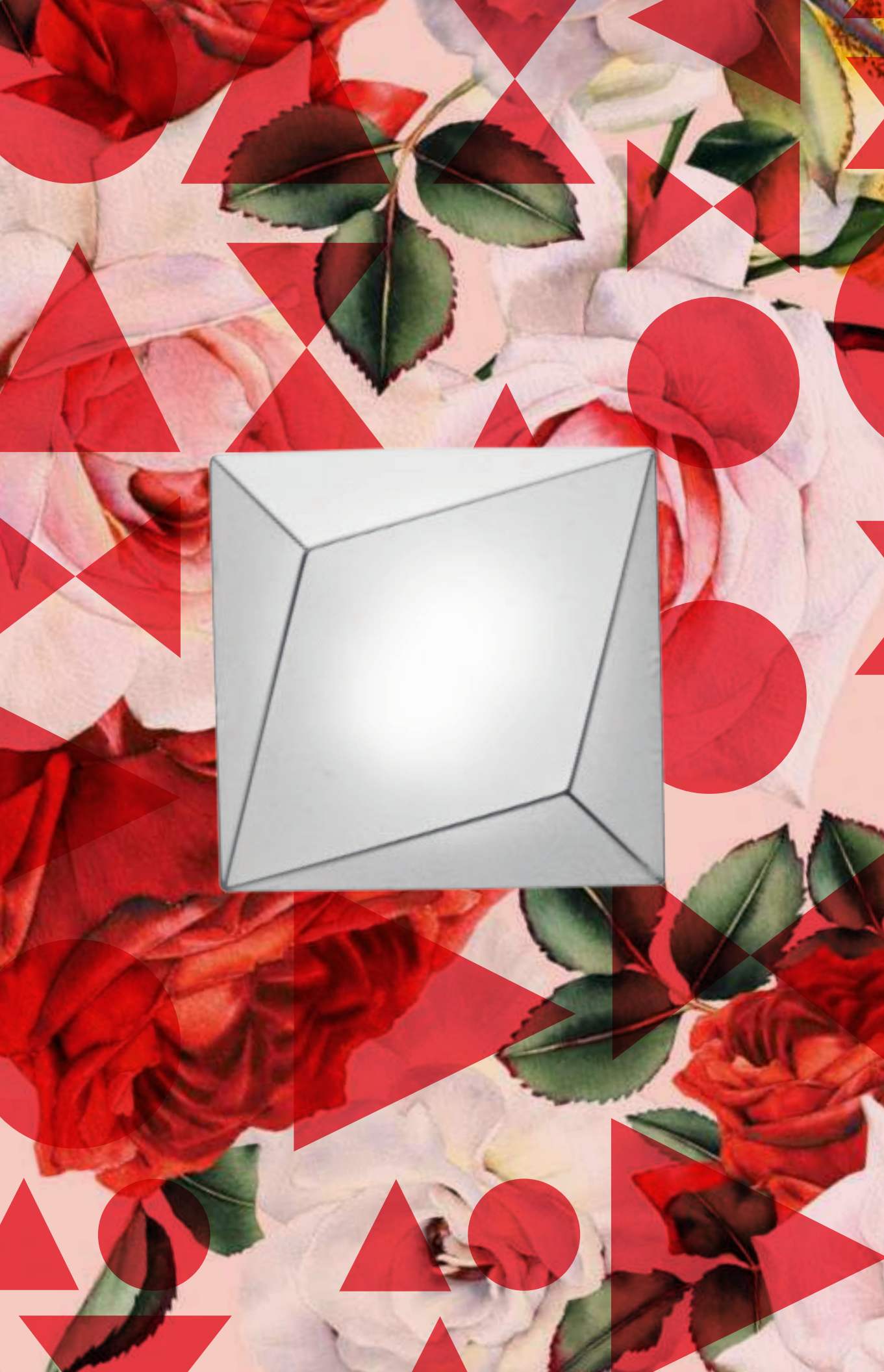

UKIYO
design Manuel Vivian



WALL/CEILING

for more information see the technical guide at p. 69

ceiling

- AURA
- BELL
- CLAVIUS
- FAIRY
- HOOPS
- NAFIR
- ORCHID
- SKIN
- SKIRT
- SOL
- URBAN
- URBAN MINI
- VELVET
- VOLUPTAS

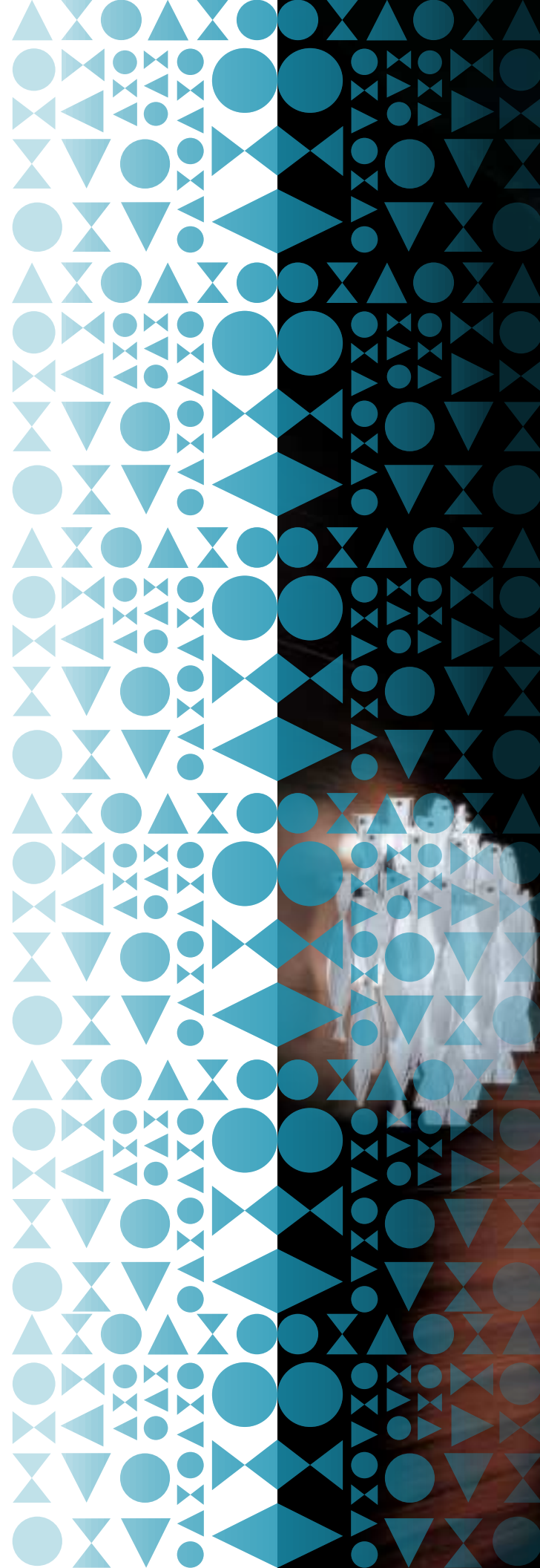



[for more information see the technical guide at p. 7](#)







BELL
design Manuel Vivian



[for more information see the technical guide at p. 11](#)

CEILING



CEILING



FAIRY
design Manuel Vivian



for more information see the technical guide at p. 22

HOOPS
design Giovanni Barbato

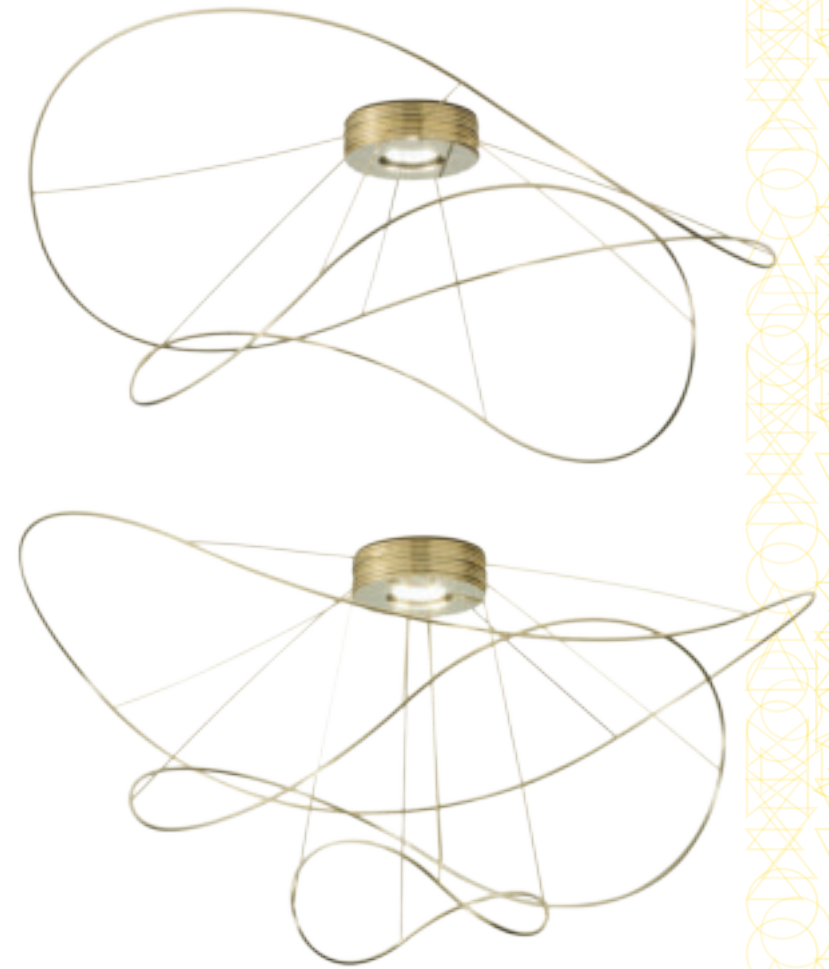

for more information see the technical guide at p. 30



NAFIR
design Karim Rashid



[for more information see the technical guide at p. 41](#)

ORCHID
design Rainer Mutsch

CEILING

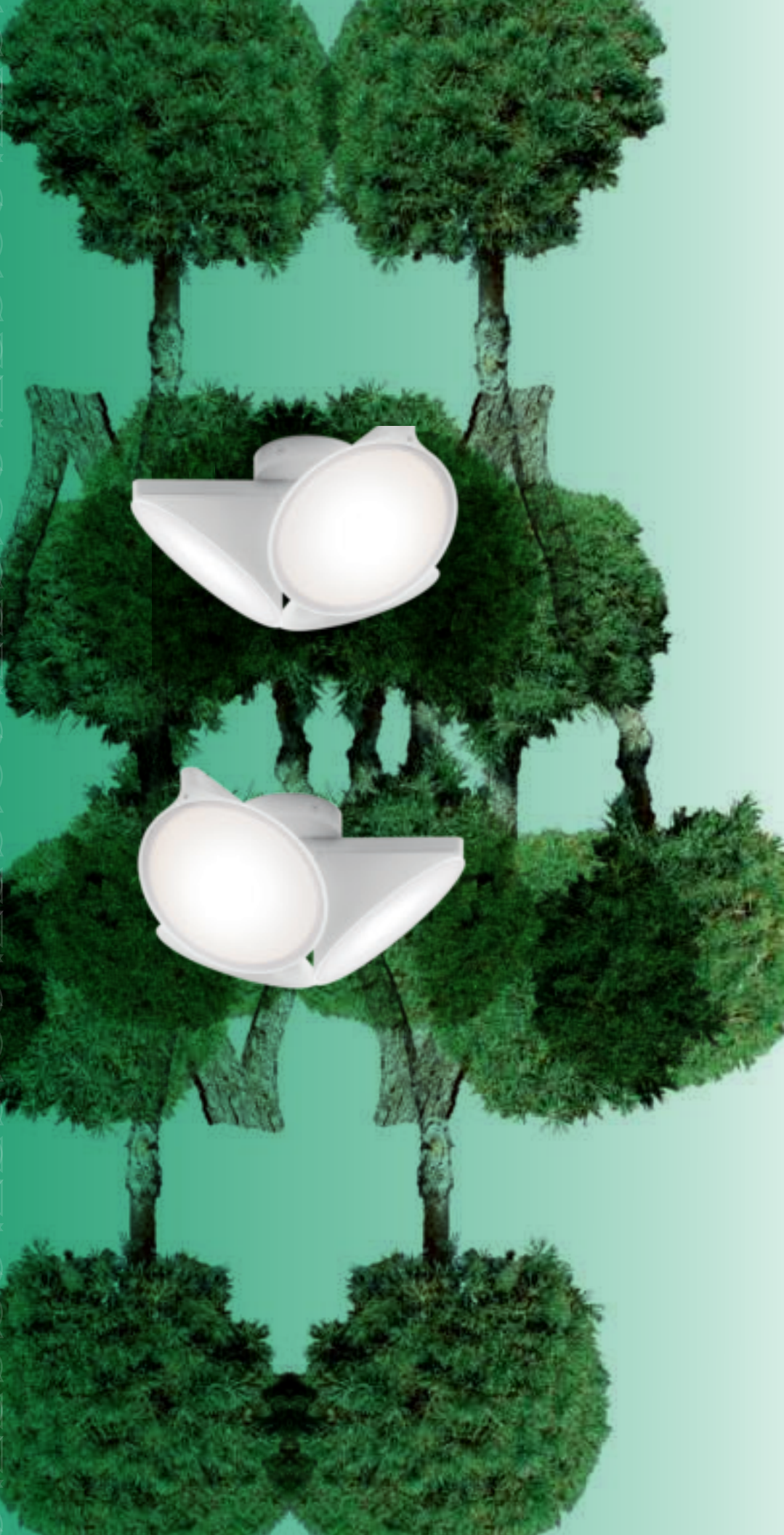

for more information see the technical guide at p. 45

SKIN
design Manuel Vivian



CEILING

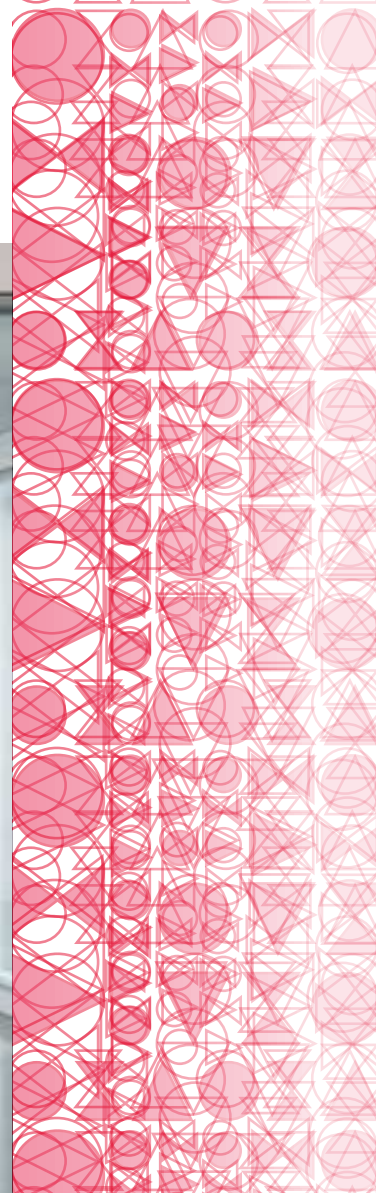

SKIRT
design Manuel Vivian

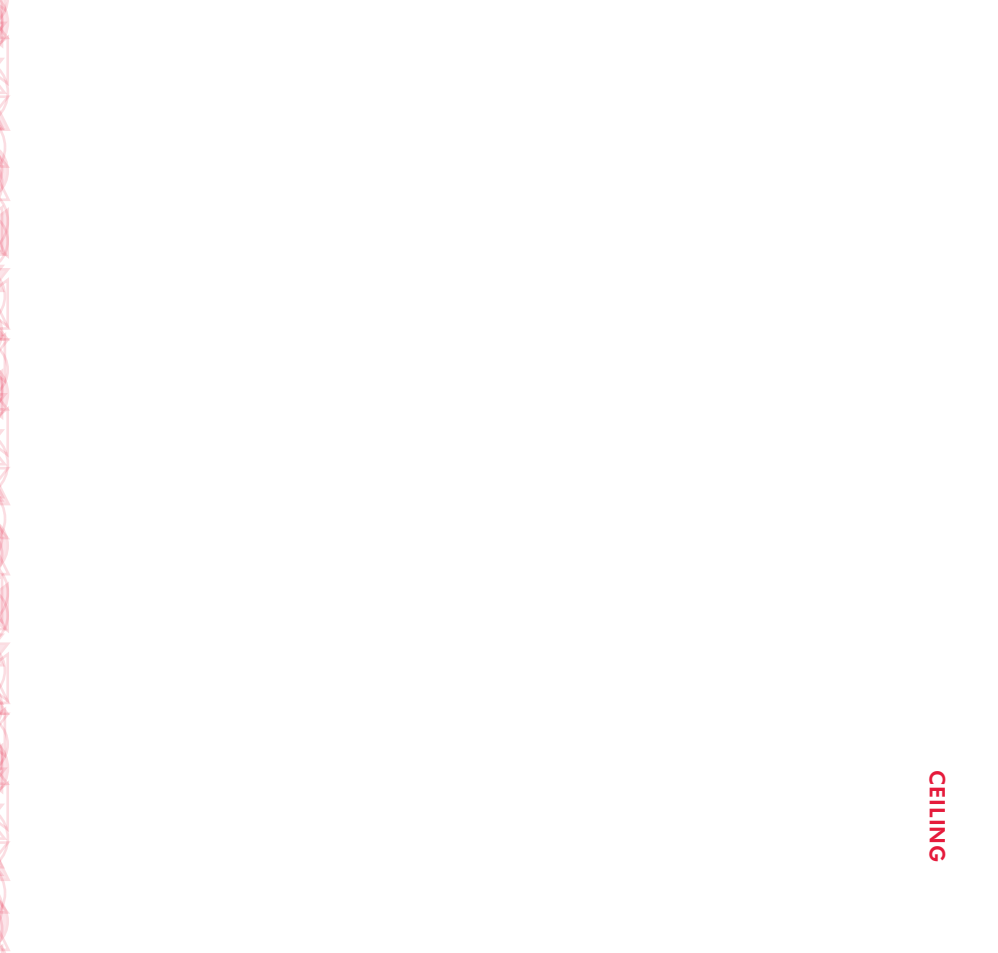

CEILING



for more information see the technical guide at p. 51

for more information see the technical guide at p. 53

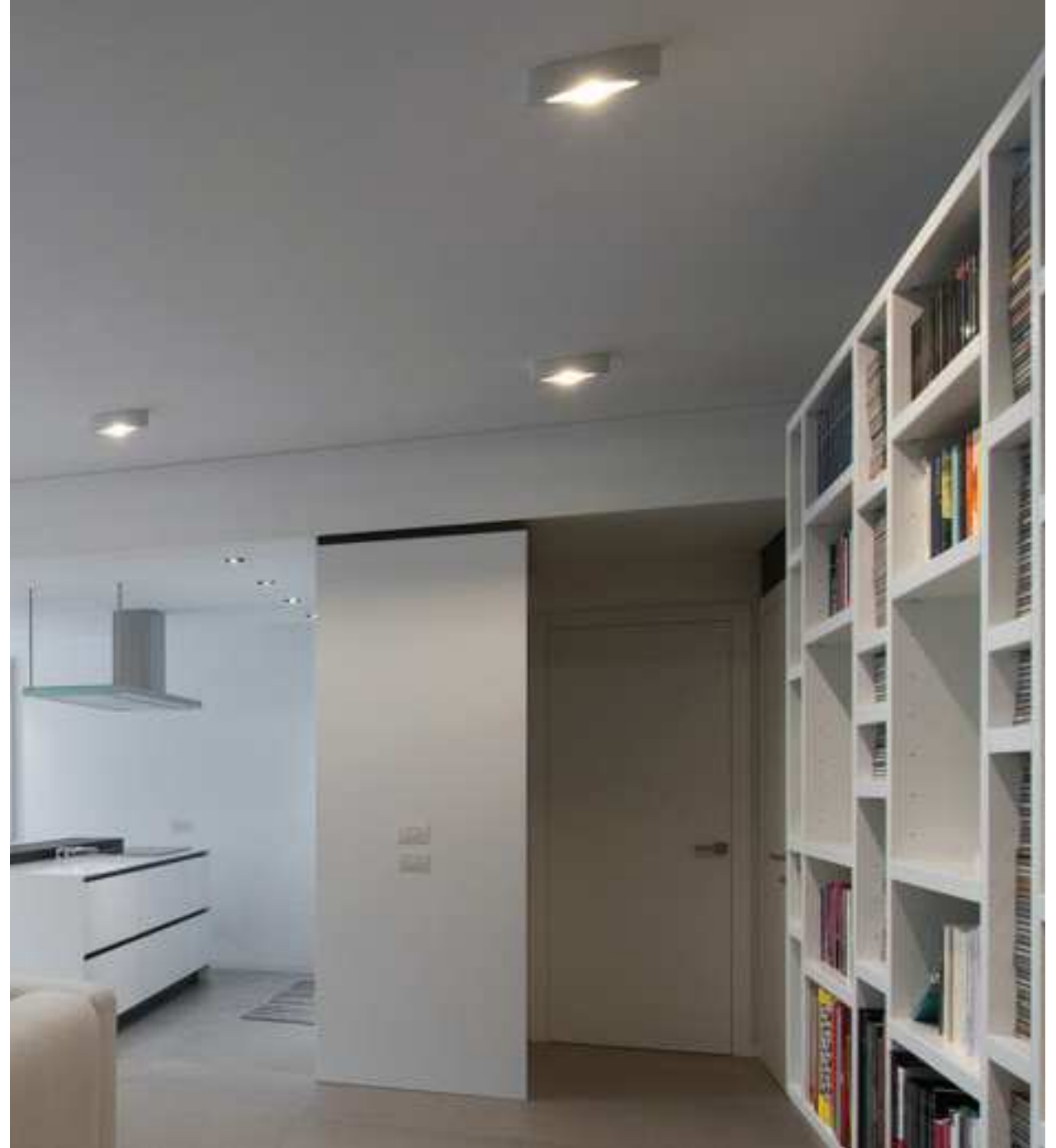

URBAN
design Dima Loginoff

CEILING



[for more information see the technical guide at p. 70](#)

URBAN MINI
design Dima Loginoff

CEILING

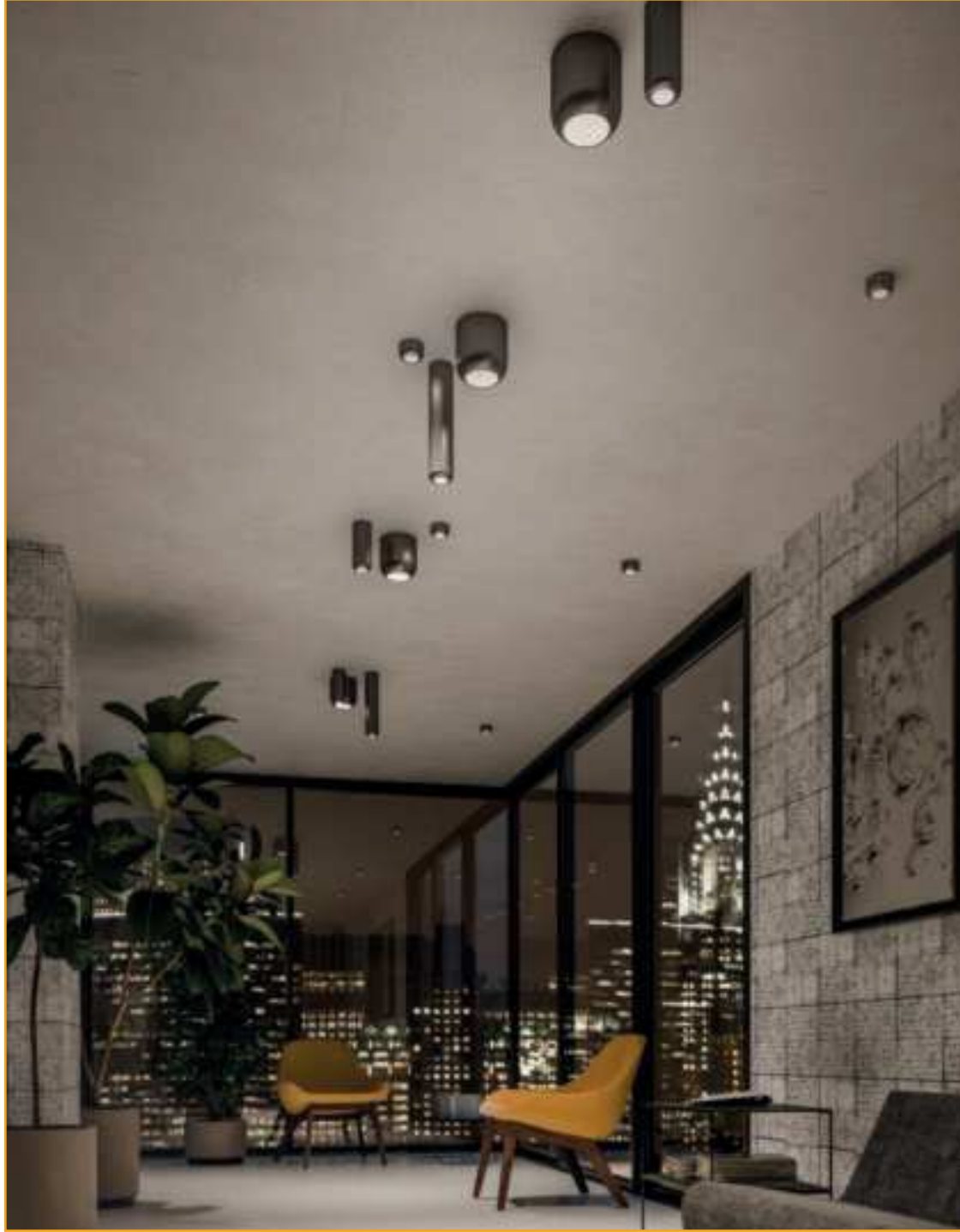

[for more information see the technical guide at p. 72](#)

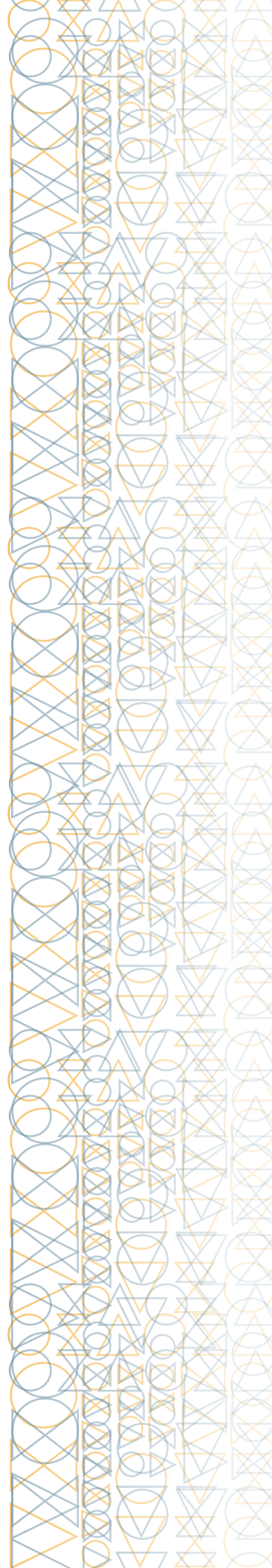

CEILING

VELVET
design Manuel Vivian



CEILING

[for more information see the technical guide at p. 75](#)

VOLUPTAS
design Lorenzo Truant

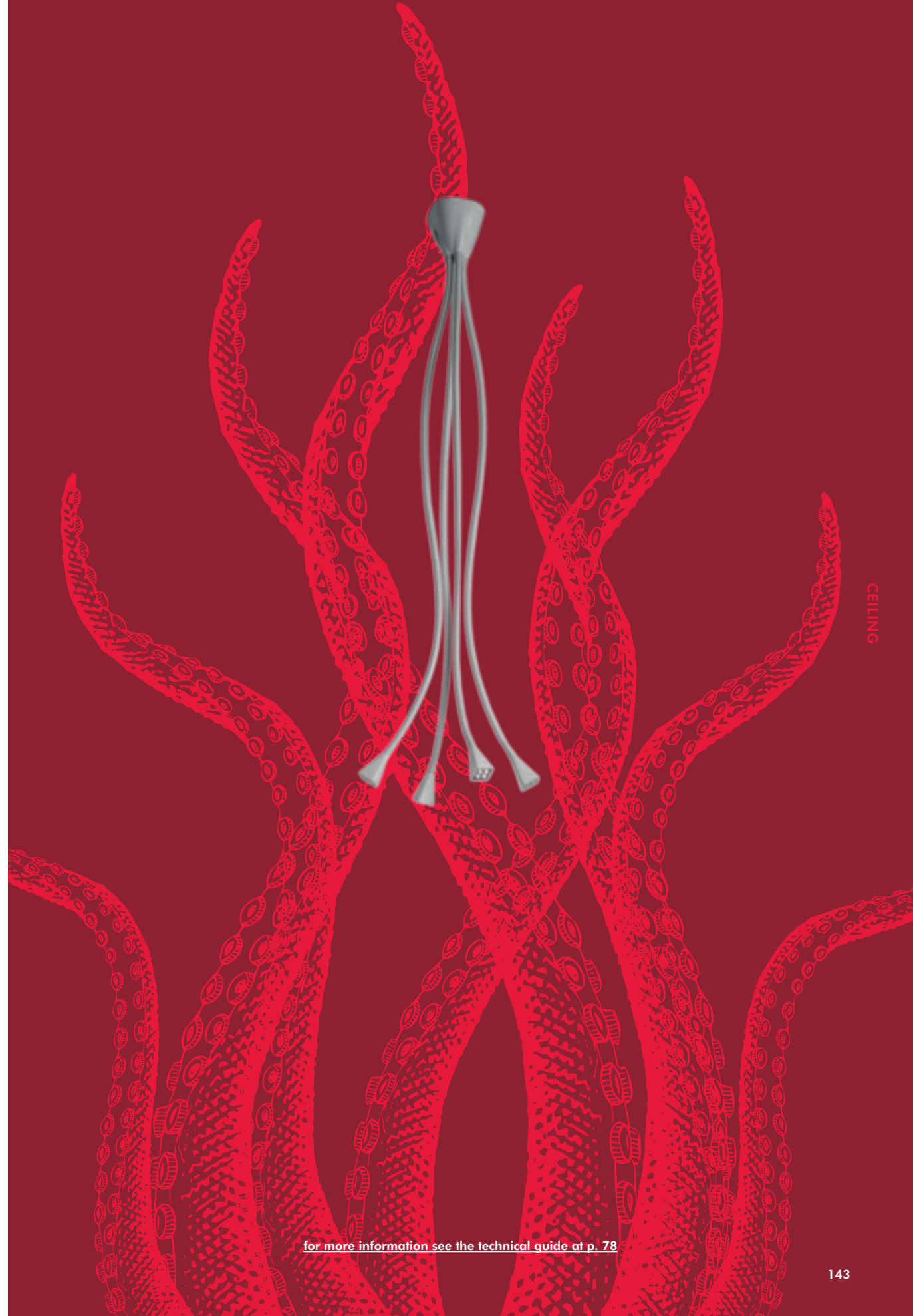

CEILING

[for more information see the technical guide at p. 78](#)

table

AIBU
AX 20
CLAVIUS
MUSE
SKIRT



AIBU
design Giovanni Barbato



[for more information see the technical guide at p. 4](#)

AX 20
design Manuel Vivian



TABLE

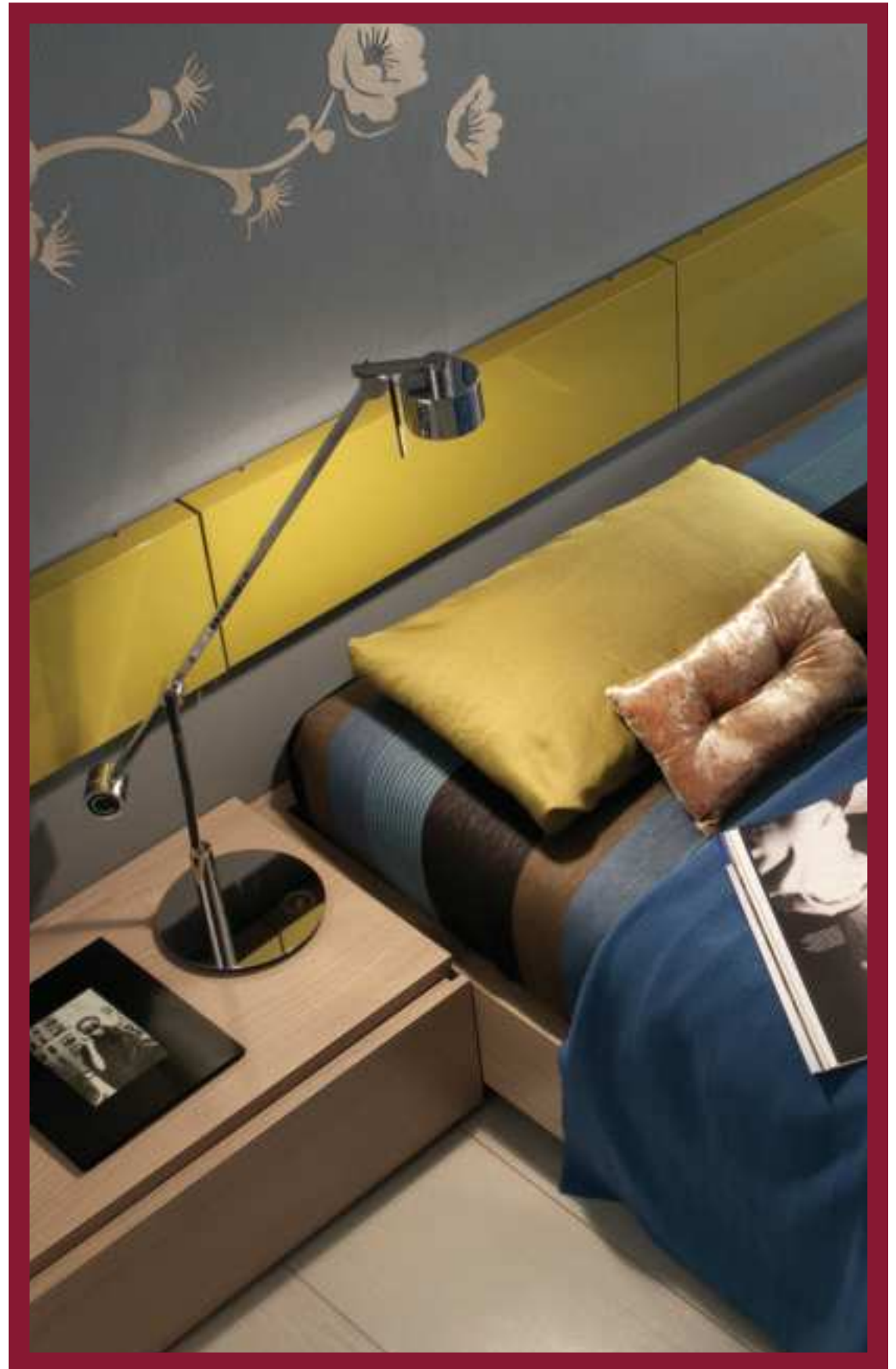

TABLE

[for more information see the technical guide at p. 10](#)



CLAVIUS
design Manuel Vivian



TABLE

[for more information see the technical guide at p. 17](#)

MUSE
design Sandro Santantonio

TABLE



[for more information see the technical guide at p. 41](#)

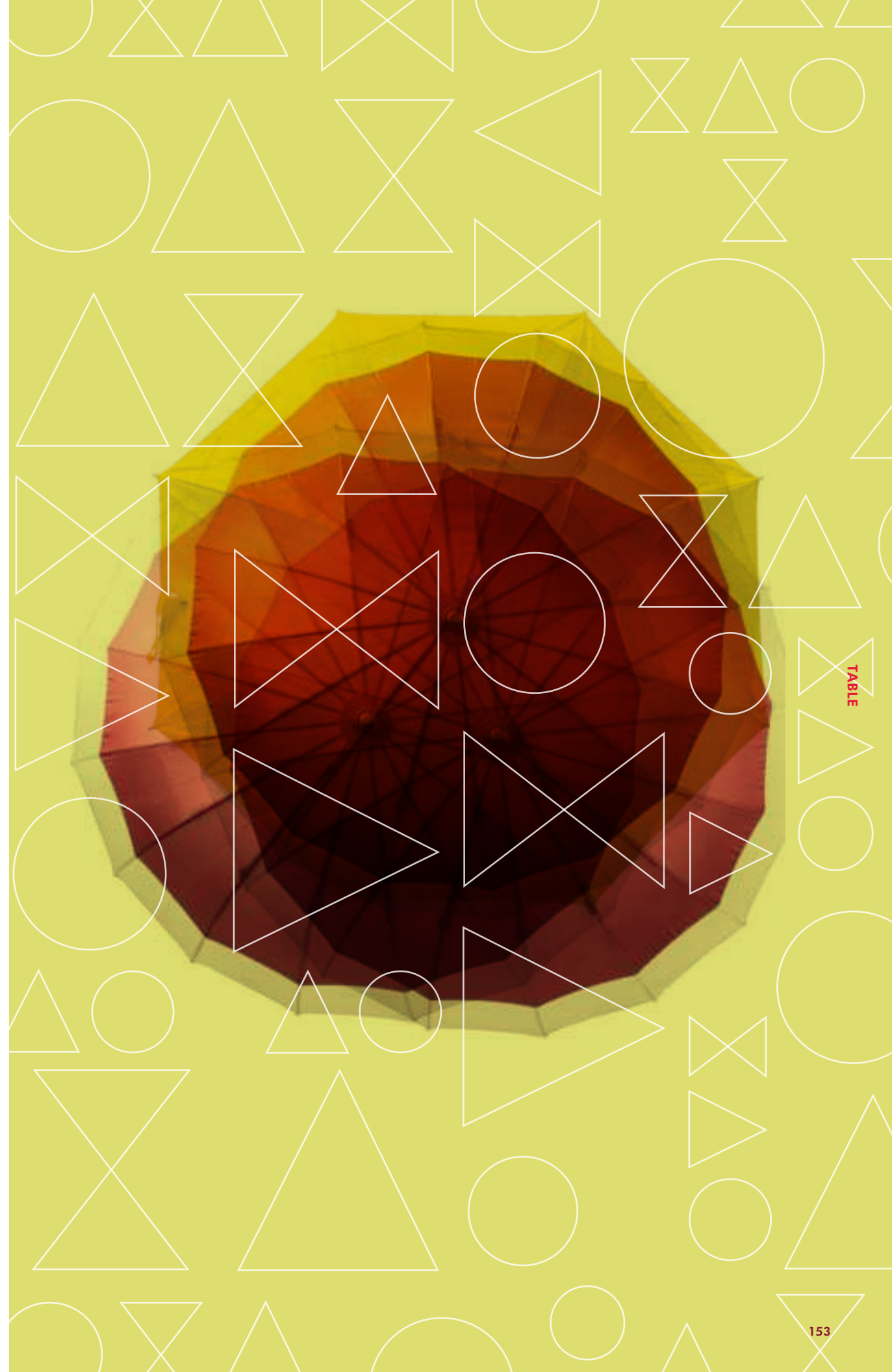

TABLE

SKIRT
design Manuel Vivian

TABLE



[for more information see the technical guide at p. 57](#)

floor

AX 20
CLAVIUS
MELTING POT
ORCHID



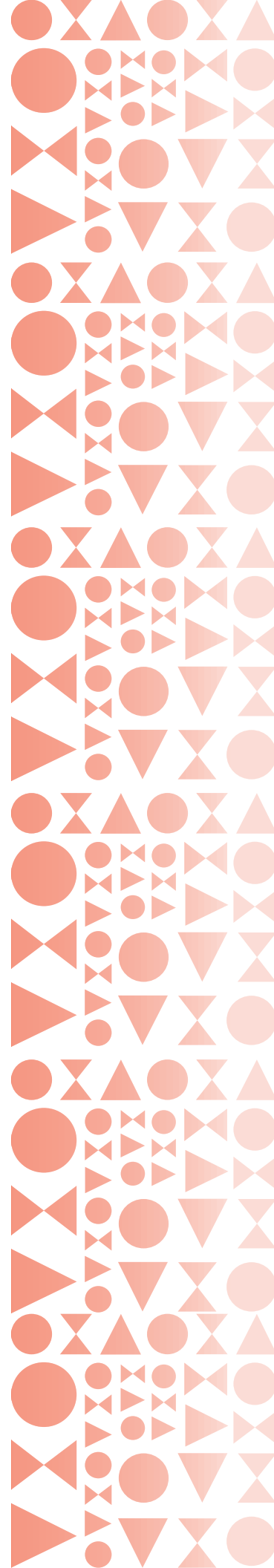

AX 20
design Manuel Vivian



[for more information see the technical guide at p. 10](#)

FLOOR



CLAVIUS
design Manuel Vivian



FLOOR

[for more information see the technical guide at p. 17](#)

MELTING POT
design Sandro Santantonio

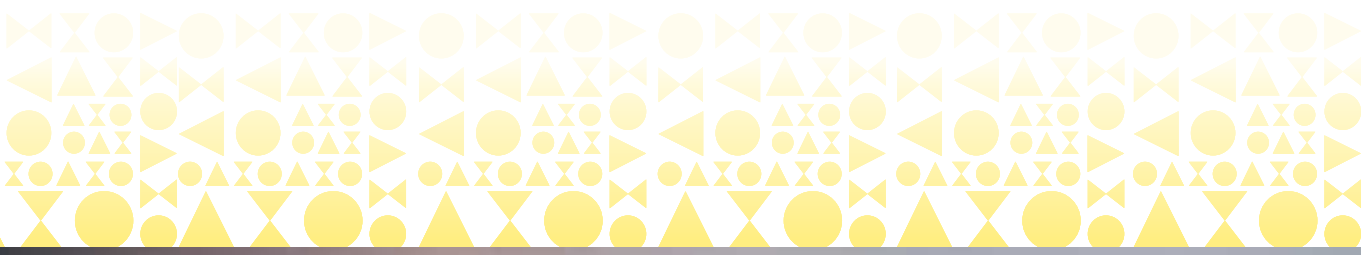

FLOOR

FLOOR



[for more information see the technical guide at p. 37](#)

ORCHID
design Rainer Mutsch



FLOOR

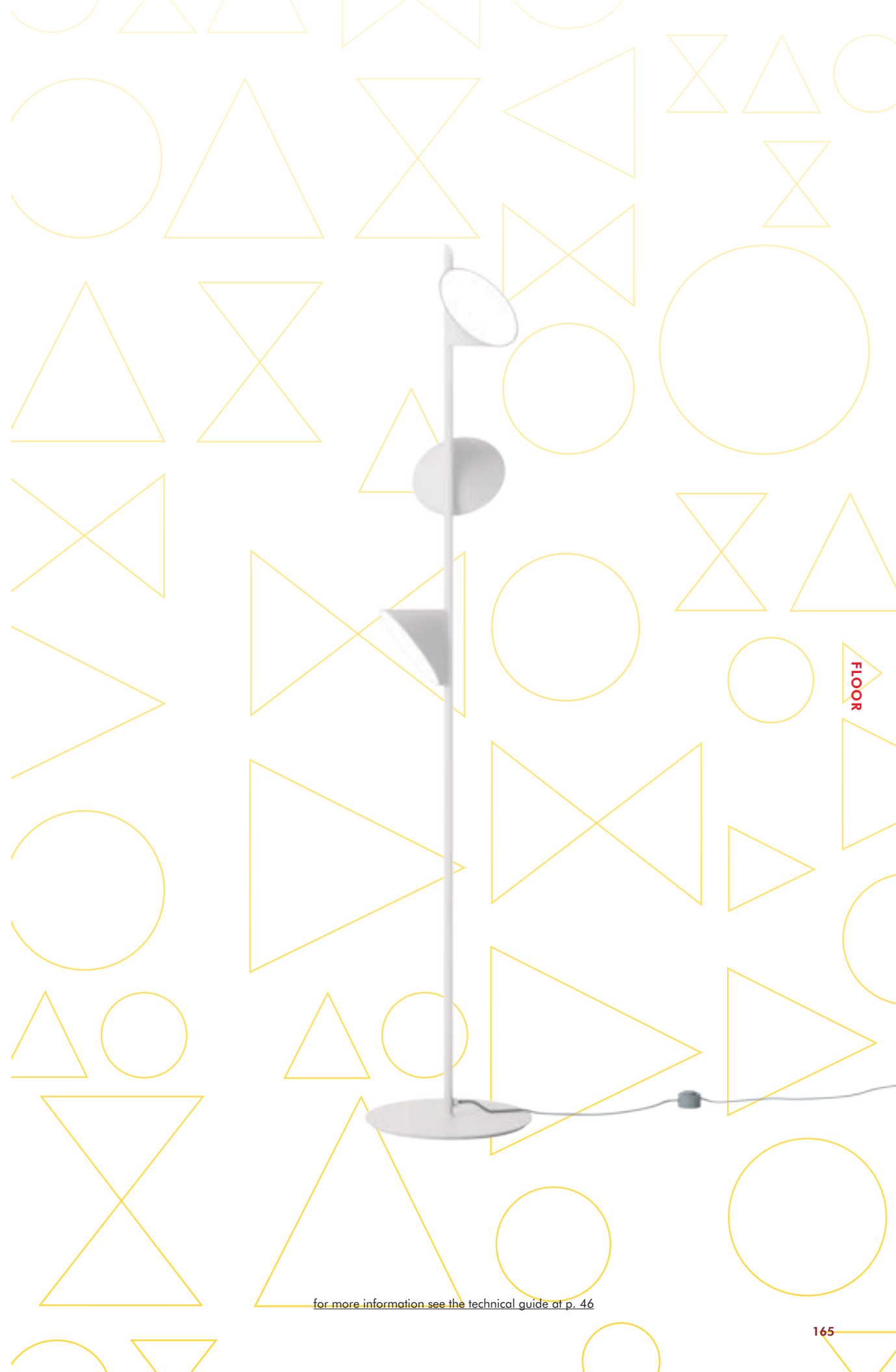

FLOOR

for more information see the technical guide at p. 46

recessed

CRYSTAL SPOTLIGHT

FAIRY

FAVILLA

FEDORA

NAFIR

SPILLRAY



CRYSTAL SPOTLIGHT
design Manuel Vivian



[for more information see the technical guide at p. 18](#)

RECESSED





FAIRY
design Manuel Vivian



for more information see the technical guide at p. 22



FEDORA
design Dima Loginoff

RECESSED



RECESSED

[for more information see the technical guide at p. 26](#)

NAFIR
design Karim Rashid

RECESSED



[for more information see the technical guide at p. 42](#)

SPILLRAY
design Manuel Vivian



[for more information see the technical guide at p. 57](#)

large scale

- ANADEM
- BELL
- EULER
- FRAMEWORK LED
- LAYERS
- MELTING POT
- PLUMAGE
- SHATTER LED
- SKIN
- SKIRT
- U-LIGHT
- VELVET



ANADEM
design Vanessa Vivian



LARGE SCALE



LARGE SCALE

for more information see the technical guide at p. 6

BELL
design Manuel Vivian

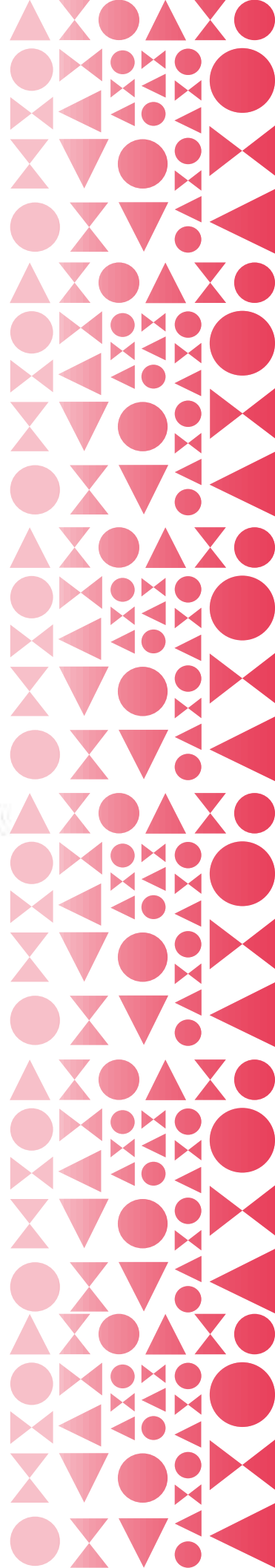

LARGE SCALE

for more information see the technical guide at p. 12



LARGE SCALE



LARGE SCALE

BELL
design Manuel Vivian

LARGE SCALE



for more information see the technical guide at p. 12



LARGE SCALE



LARGE SCALE



EULER
design Cambi Scatena Turini



for more information see the technical guide at p. 18

FRAMEWORK LED
design Manuel Vivian

LARGE SCALE



for more information see the technical guide at p. 28

FRAMEWORK LED
design Manuel Vivian



for more information see the technical guide at p. 28

LAYERS
design Vanessa Vivian



LARGE SCALE



LARGE SCALE

for more information see the technical guide at p. 32

MELTING POT
design Sandro Santantonio



LARGE SCALE

for more information see the technical guide at p. 38

MELTING POT
design Sandro Santantonio



LARGE SCALE

for more information see the technical guide at p. 35-37

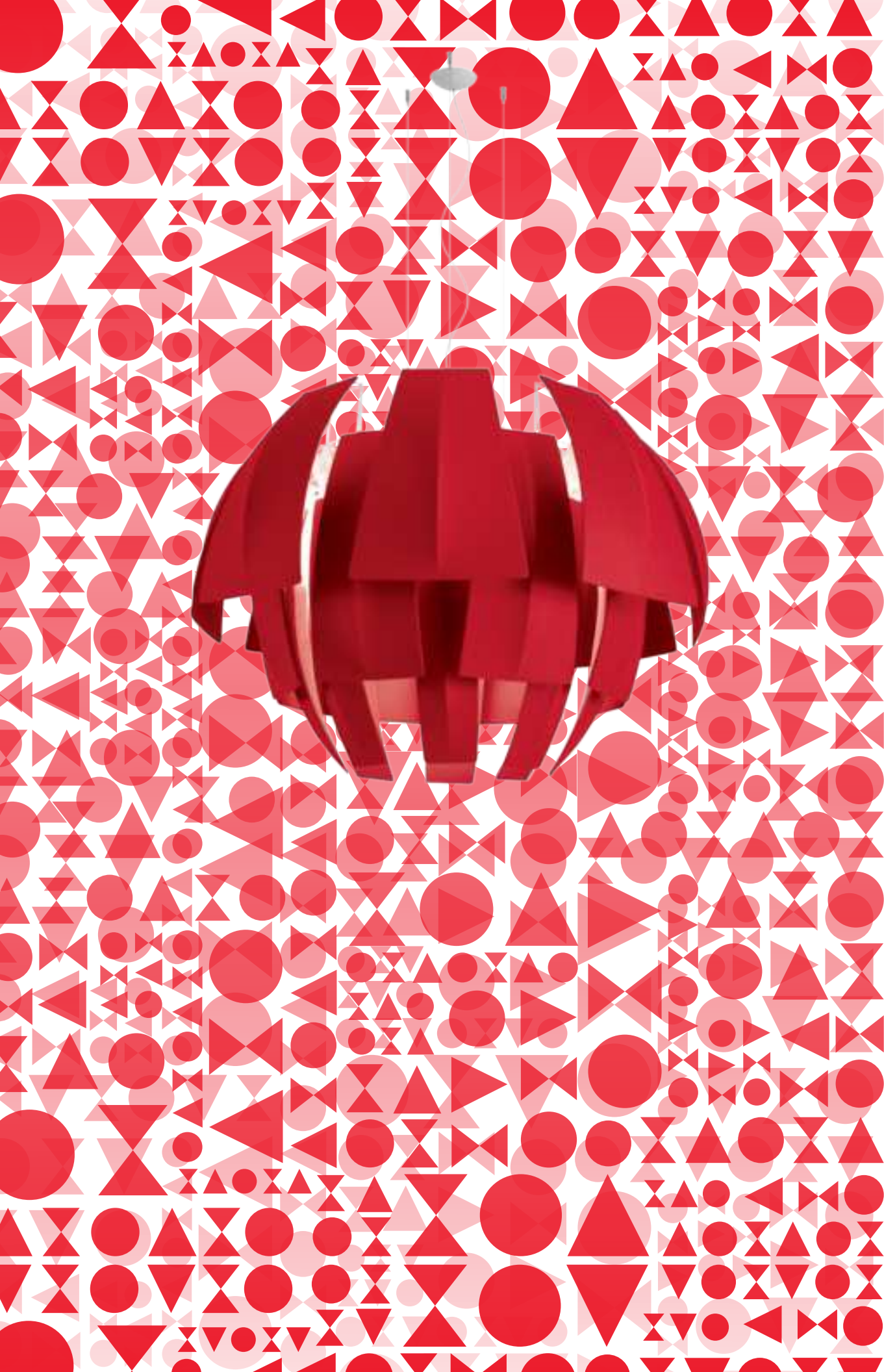

PLUMAGE
design Vanessa Vivian



LARGE SCALE

[for more information see the technical guide at p. 46](#)



LARGE SCALE

SHATTER LED
design Serge & Robert Cornelissen

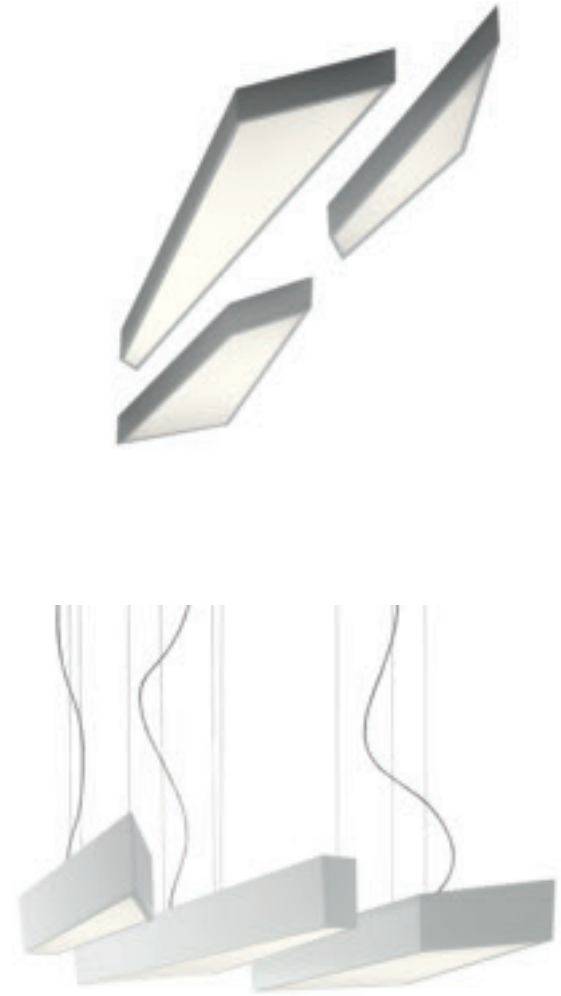

LARGE SCALE

for more information see the technical guide at p. 49-50

SKIN
design Manuel Vivian



LARGE SCALE



for more information see the technical guide at p. 52

SKIRT
design Manuel Vivian



LARGE SCALE

for more information see the technical guide at p. 55

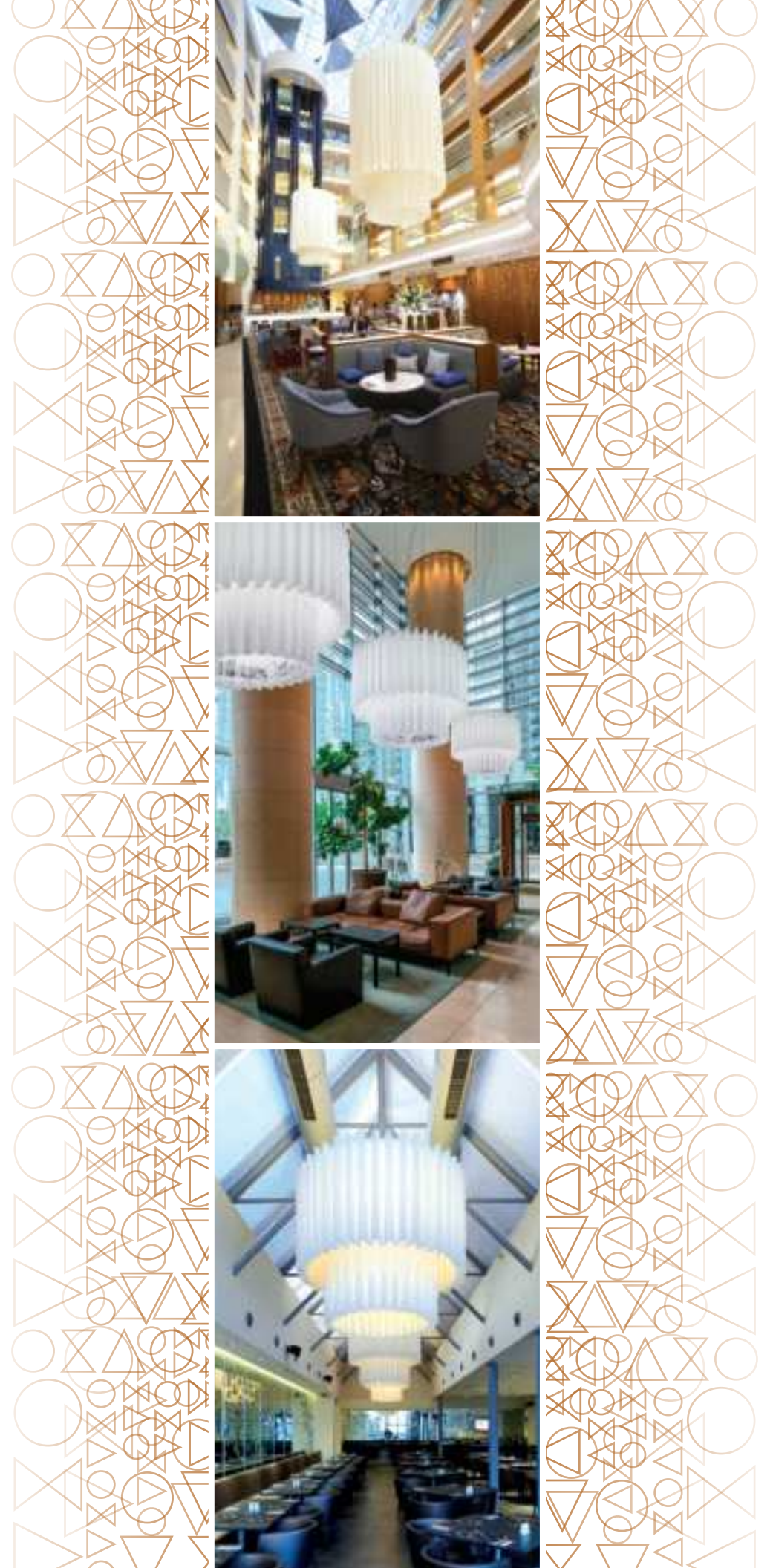

LARGE SCALE

SKIRT
design Manuel Vivian

LARGE SCALE



[for more information see the technical guide at p. 55](#)

U-LIGHT
design Timo Ripatti



LARGE SCALE

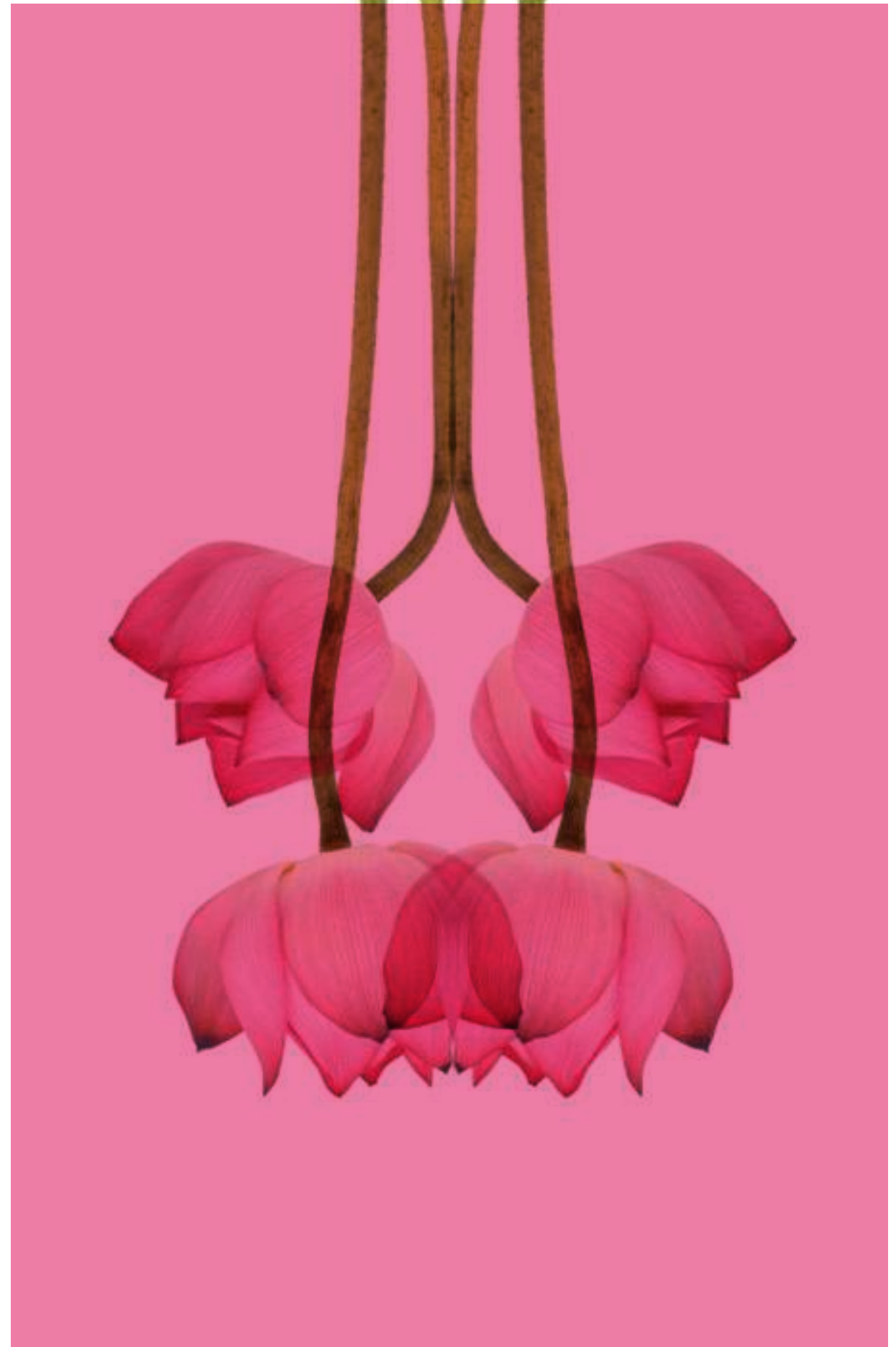

[for more information see the technical guide at p. 68](#)

U-LIGHT
design Timo Ripatti

LARGE SCALE



for more information see the technical guide at p. 68

LARGE SCALE



U-LIGHT
design Timo Ripatti

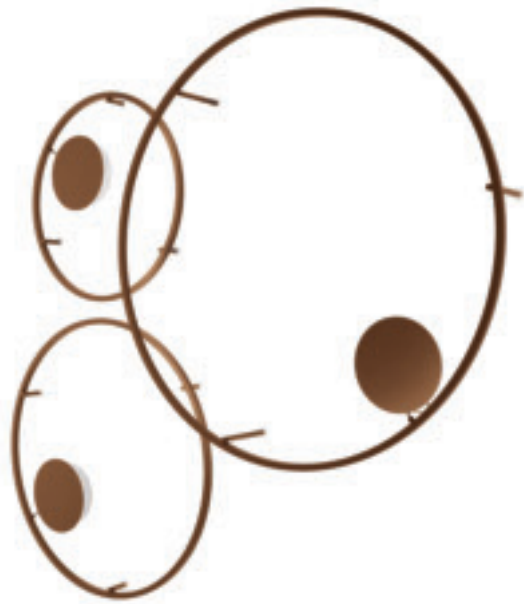
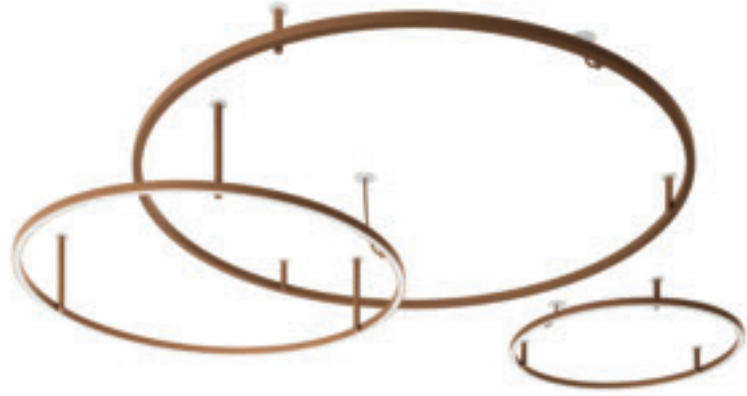

[for more information see the technical guide at p. 65-66](#)



U-LIGHT
design Timo Ripatti

LARGE SCALE



for more information see the technical guide at p. 65

LARGE SCALE



U-LIGHT
design Timo Ripatti

LARGE SCALE



LARGE SCALE



for more information see the technical guide at p. 65



U-LIGHT
design Timo Ripatti

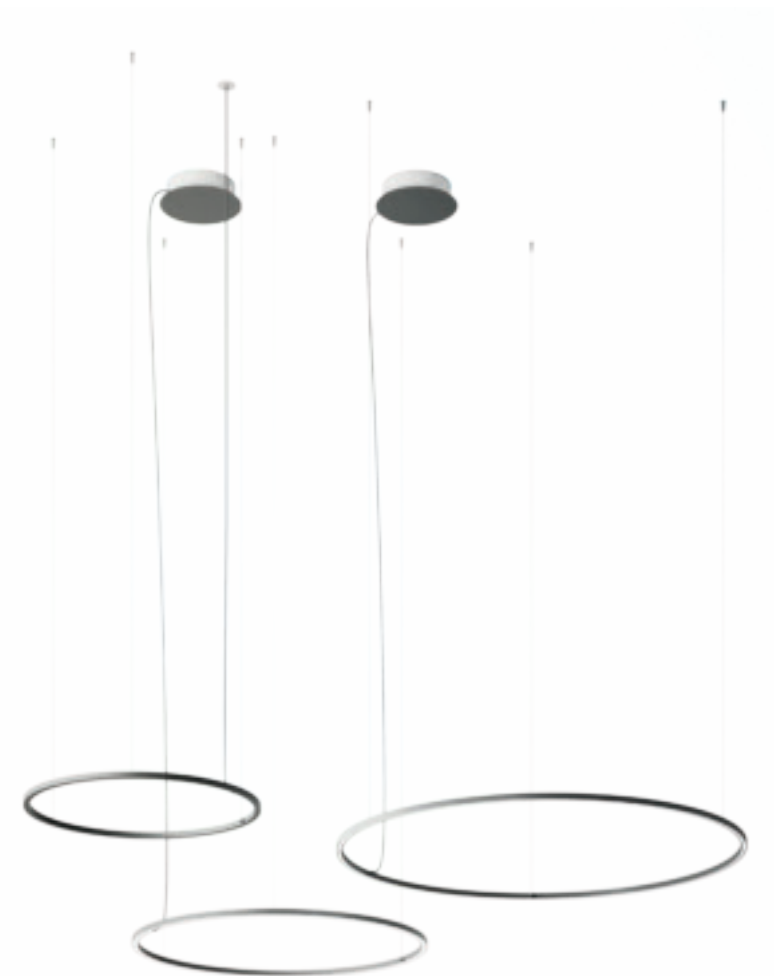

LARGE SCALE

VELVET
design Manuel Vivian



LARGE SCALE

LARGE SCALE

for more information see the technical guide at p. 75-77

bespoke

AURA
CLAVIUS
U-LIGHT
VIRTUS



Restaurant Belvedere / Hergiswil, Switzerland

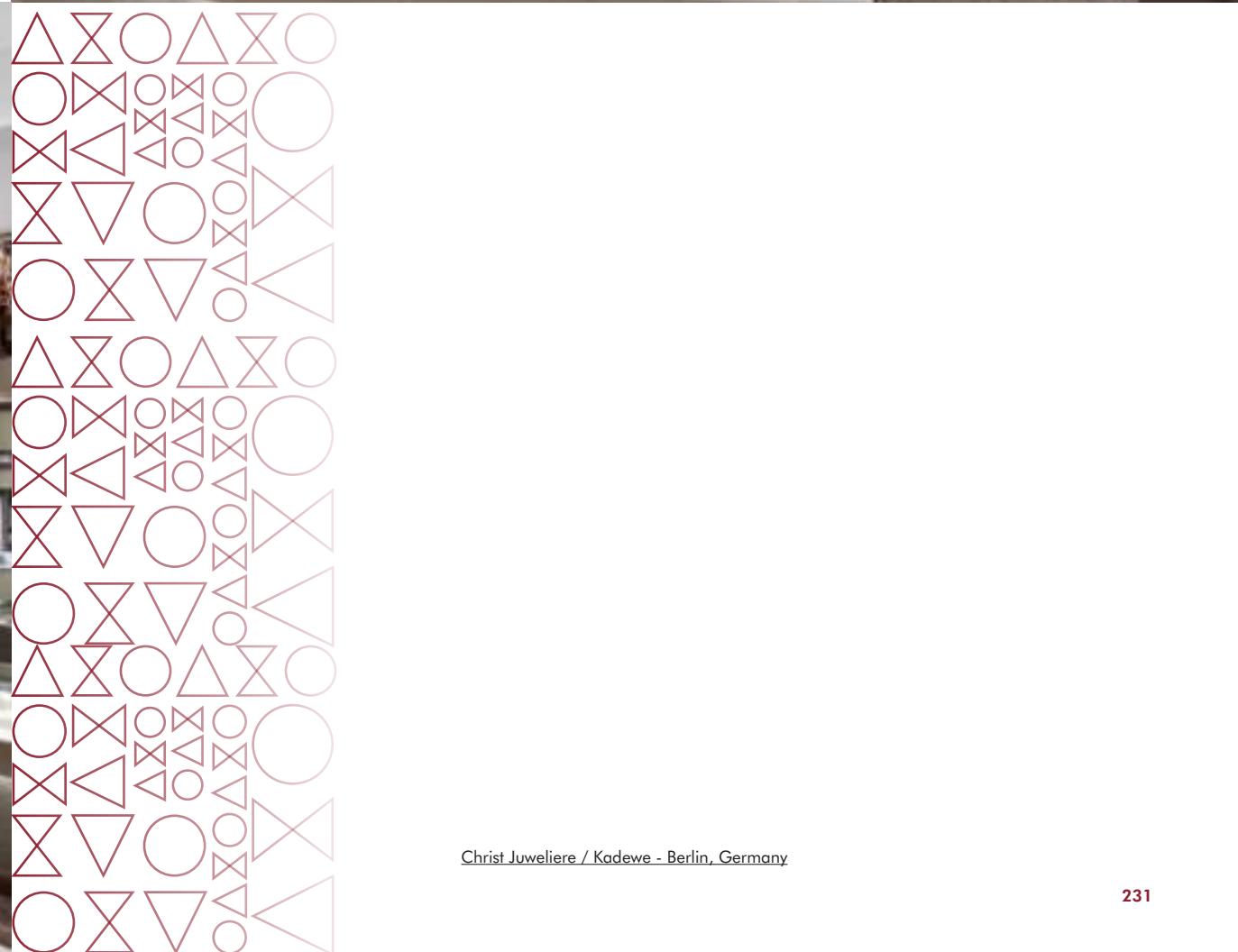



AURA
design Manuel Vivian

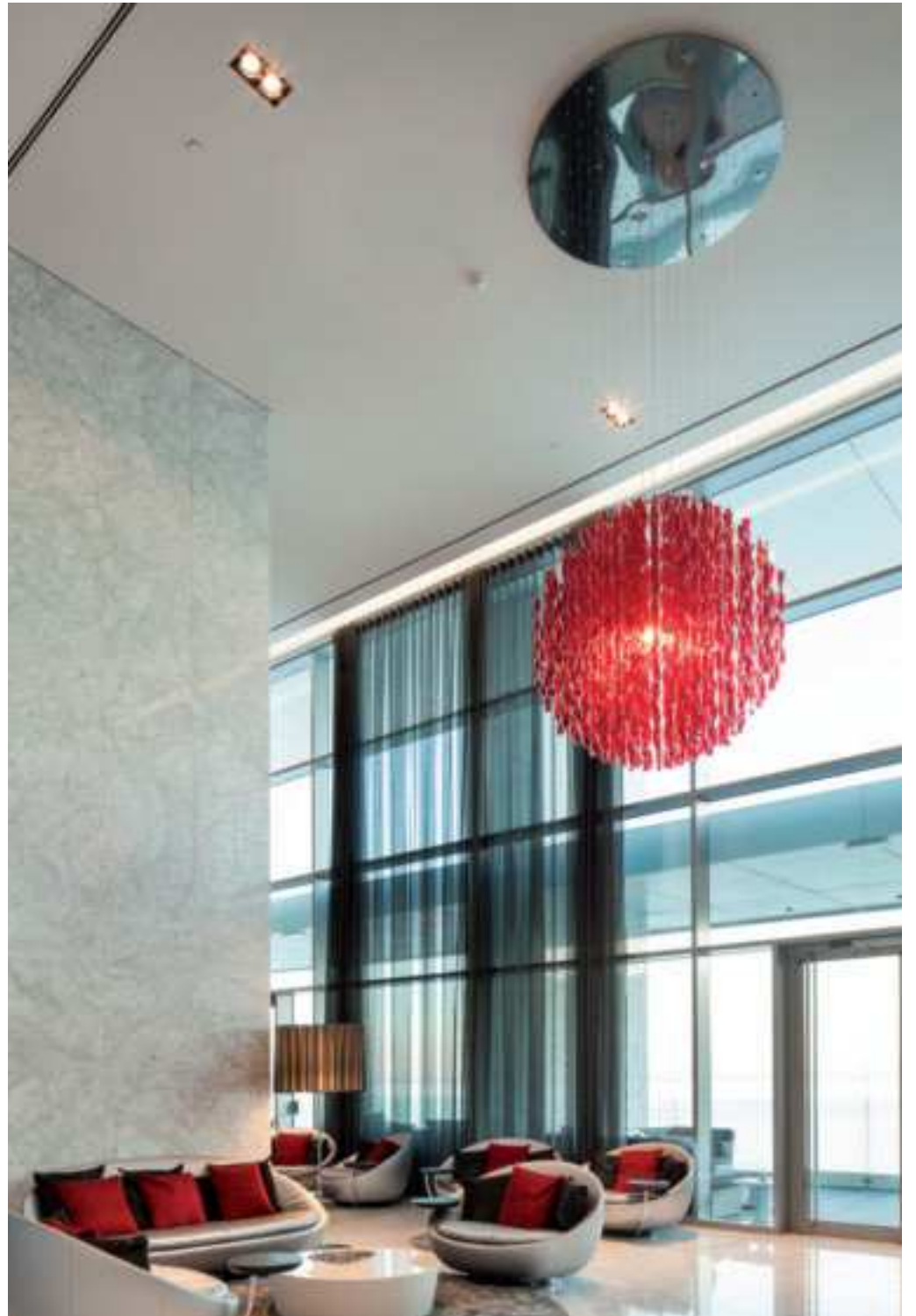

BESPOKE

Hotel Myriad, Lisbon - Portugal

CLAVIUS
design Manuel Vivian



BESPOKE

100% Capri / Miami, Usa



BESPOKE

U-LIGHT
design Timo Ripatti

BESPOKE



VIRTUS
design Manuel Vivian



BESPOKE

Axo Light si riserva il diritto di apportare ai modelli, senza alcun preavviso, qualsiasi modifica ritenesse opportuna. Axo Light non risponde per eventuali danni a persone o cose causati da una non corretta installazione dei propri apparecchi d'illuminazione. I dati riportati sono puramente indicativi; è possibile che siano riportati degli errori di stampa.

Axo Light reserves itself the right to introduce any changes to its own models, without prior notice. Axo Light is not liable for injuries or damage due to the incorrect installation of its fixtures. The details given here are intended purely as guidance as errors may have occurred during the printing process. Le schede tecniche dei prodotti Axo Light sono scaricabili direttamente dal nostro sito: www.axolight.it

Axo Light technical sheets can be downloaded directly from our website: www.axolight.it

creative direction/art direction/design/photo illustrations

TEIKNA DESIGN
Claudia Neri, creative/design director
Elisa Stagnoli, design assistant

editing and coordination

Fabrizio Cettina

printed and bound in Italy

Grafiche Antiga spa

Renderings

nudesign srl
zenzero & co
neiko srl

photolito

Graficart Arti Grafiche srl
Fotolito Quattrifoglio
Studio Varianti
Studio Pointer

photocredits

Florindo Romandini
Studio Varianti
Studio Pointer
Bluemotion

AXO LIGHT srl
via Moglianese, 44
30037 Scorzè (Venezia) Italy
t. +39 041 5845193
f +39 041 5845060
axolight@axolight.it
axolight.it

AXO LIGHT USA INC.
22 Shelter Rock Lane, Ste #104
Danbury, CT, 06810 USA
t +1 (203) 730 0452
f +1 (203) 730 0460
info@axolightusa.com
axolightusa.com

AXO LIGHT ASIA LIMITED
RM305-306, Office Building
No.2 Tiantaiyi Road
Science Town, Luogang District
510663 Guangzhou - PRC
t +86 20 38316571
f +86 20 38251165
axo.asia@axolight.asia
axolight.it

Axolight bespoke
design

Italy
United States
China

axolight.it

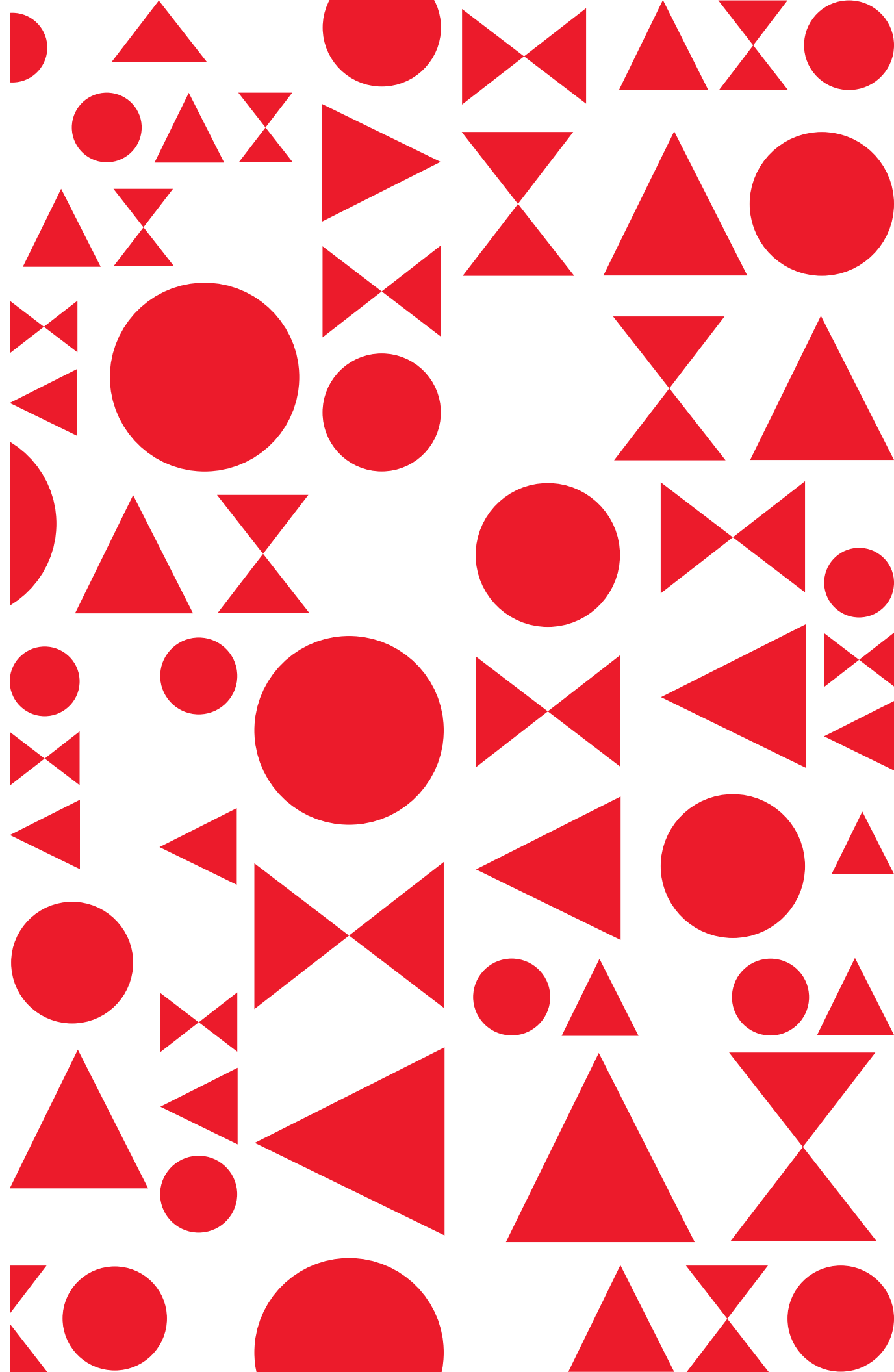



TECHNICAL INFO

2017/18

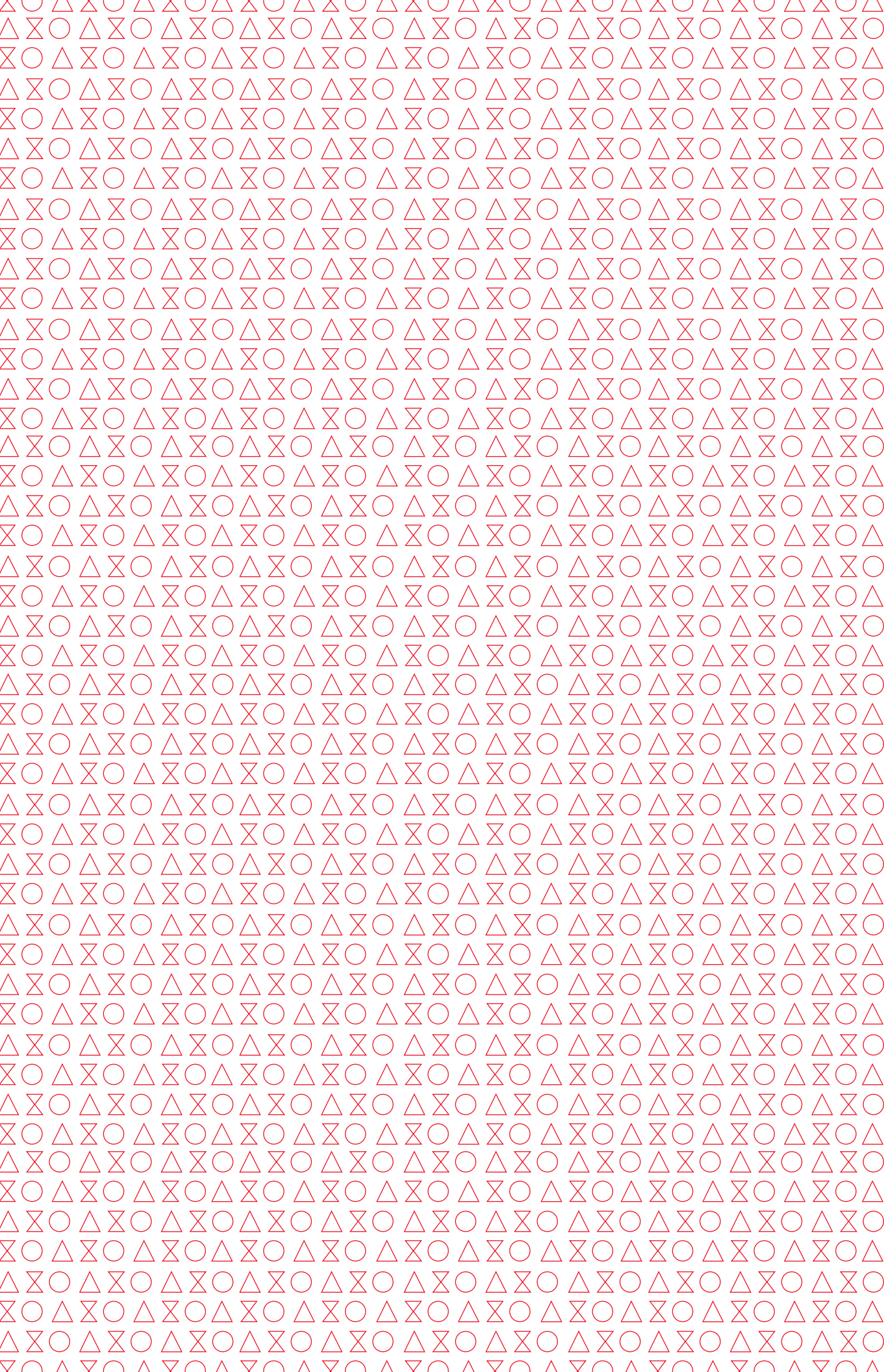

Axolight bespoke
design

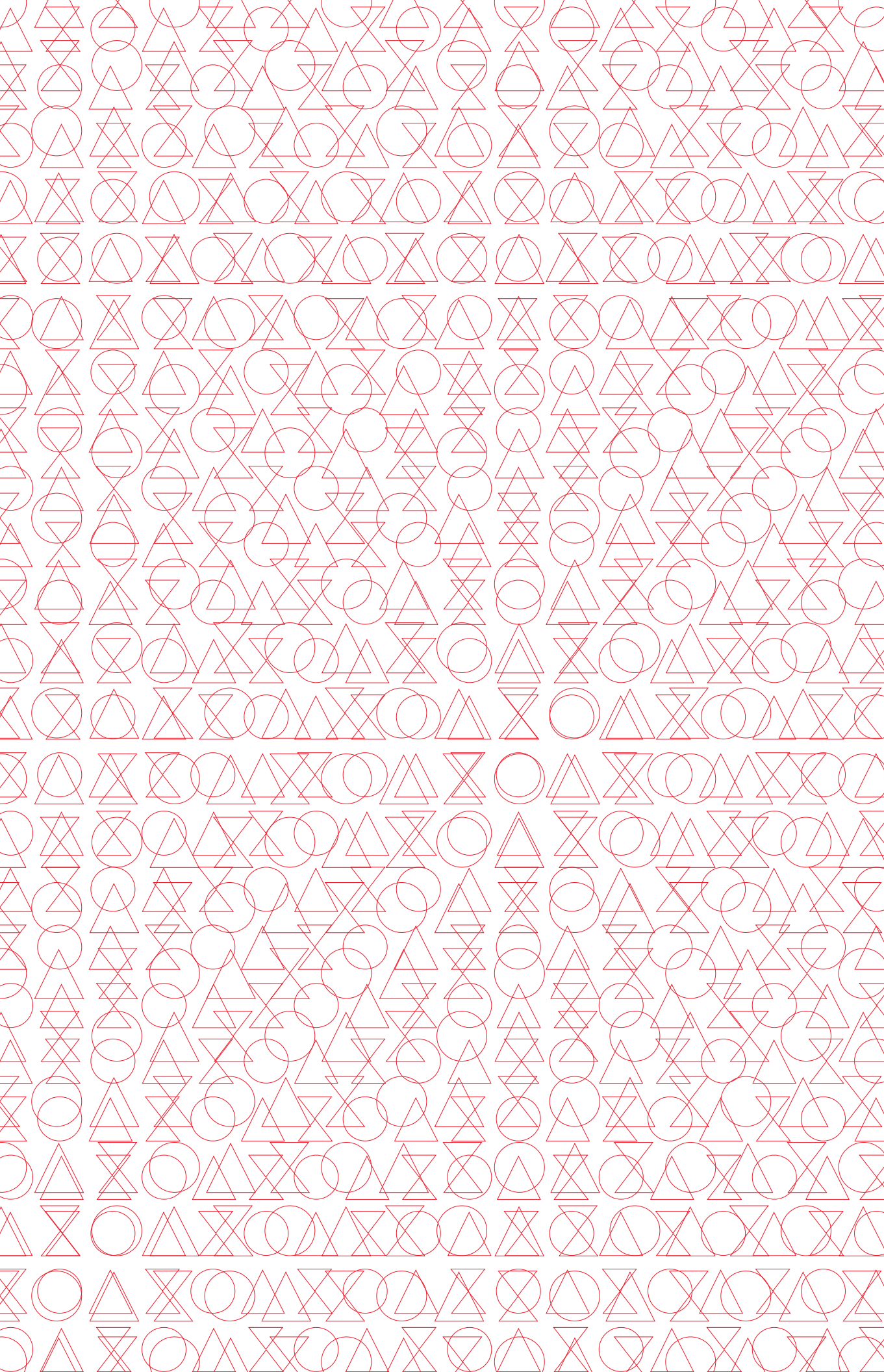

AIBU
page 4

ALRISHA
page 4

ALYSOID
page 5-6

ANADEM
page 6-7

AURA
page 7-9

AX 20
page 10

BELL
page 11-13

CLAVIUS
page 13-17

CRYSTAL SPOTLIGHT
page 18

EULER
page 18-19

EXPLO
page 20-21

FAIRY
page 22-25

FAVILLA
page 25

FEDORA
page 26-27

FRAMEWORK LED
page 28-29

HOOPS
page 30-31

LAYERS
page 32-33

LIK
page 34

MELTING POT
page 34-38

MOMUS MINI
page 38

MOUNTAIN VIEW
page 38

MUSE
page 39-41

NAFIR
page 41-42

NECKY
page 43

NELLY
page 43

NELLY STRAIGHT
page 44

ORCHID
page 44-46

PLUMAGE
page 46-47

POLIA LED
page 48

RYTHMOS
page 48-49

SHATTER LED
page 49-50

SKIN
page 51-52

SKIRT
page 53-57

SOL
page 57

SPILLRAY
page 57-62

SPIRY
page 63

STILLA
page 63

STORMY
page 64

U-LIGHT
page 65-69

UKIYO
page 69

URBAN
page 70-71

URBAN MINI
page 72-74

URIEL
page 74

VASILY
page 74

VELVET
page 75-77

VIRTUS
page 77

VOLUPTAS
page 78

LEGEND
page 80

EEL COMPATIBILITY
page 82-83

CREDITS
page 84-85

Aibu

design Giovanni Barbato

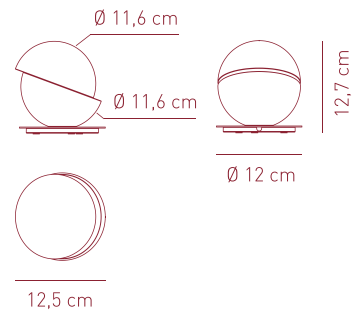

Table lamp in white triplex handmade blown glass.
Lampada da tavolo in vetro triplex soffiato e lavorato a mano, bianco.

LT AIBU

Source:
G9 1 x Max 2,5W only LED bulb

CE IP20 LED

COLOURS

○ white

Alrish

design Brian Rasmussen

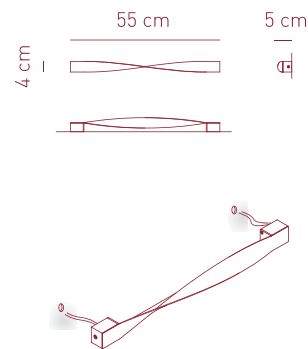

Collection consisting of white painted aluminium suspended lamp and wall lamp.
Collezione composta da lampada da parete e a sospensione in alluminio verniciato bianco.

AP ALRISH

Source:
LED 3W - 500mA - 3000K
CRI 80 - ~154 lm - 51 lm/W

CE IP20 with dedicated PSU ADA LED

COLOUR

○ wrinkled white

Driver not included

For drivers and dimming technology, please refer to our Axo Light pricelist or contact our representatives

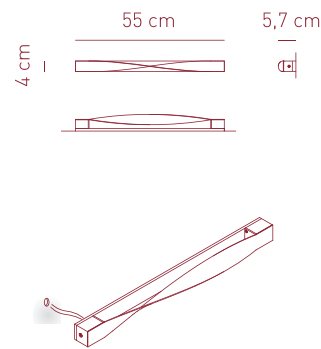

AP ALRISP with wall mounting box

Source:
LED 3W - 500mA - 3000K
CRI 80 - ~154 lm - 51 lm/W

CE IP20 with dedicated PSU ADA LED

COLOUR

○ wrinkled white

Driver not included

For drivers and dimming technology, please refer to our Axo Light pricelist or contact our representatives

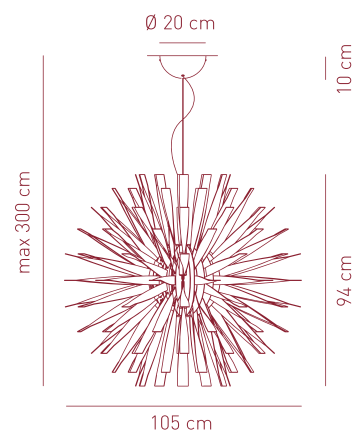

SP ALRISH

Source:
E27 1 x Max 20W LED or
1 x Max 32W fluo or
1 x Max 150W halo

CE IP20 +LED

COLOUR

○ wrinkled white

FINISH

○ white canopy

Alysoid

design Ryosuke Fukusada

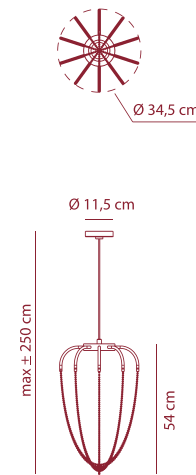

Collection consisting of aluminium suspended lamps. Available in several colours and sizes. Built-in dimmable LED light source.
Collezione di lampade a sospensione in alluminio. Disponibile in vari colori e dimensioni. La sorgente luminosa è a LED integrato dimmerabile.

SP ALYS 34

Source:
LED 20W - diffused beam - 3000K
CRI 90 - ~1230 lm - 60 lm/W

CE IP20 dimmable phase cut LED 220-240VAC

COLOURS

● anthracite grey wrinkled/
chains: black polished nickel

● anthracite grey wrinkled/
chains: natural brass

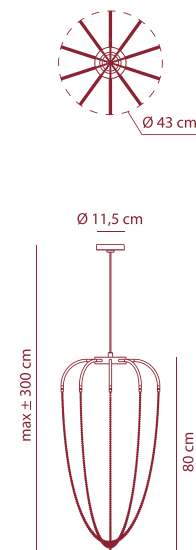

SP ALYS 43

Source:
LED 20W - diffused beam - 3000K
CRI 90 - ~1230 lm - 60 lm/W

CE IP20 dimmable phase cut LED 220-240VAC

COLOURS

● anthracite grey wrinkled/
chains: black polished nickel

● anthracite grey wrinkled/
chains: natural brass

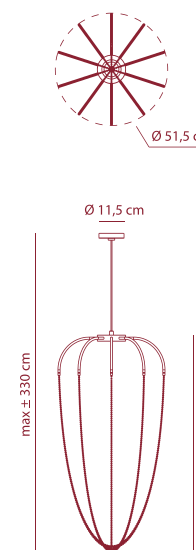

SP ALY 51 P

Source:
LED 20W - diffused beam - 3000K
CRI 90 - ~1230 lm - 60 lm/W

CE IP20 dimmable phase cut LED 220-240VAC

COLOURS

● anthracite grey wrinkled/
chains: black polished nickel

● anthracite grey wrinkled/
chains: natural brass

Alysoid

design Ryosuke Fukusada

Collection consisting of aluminium suspended lamps. Available in several colours and sizes. Built-in dimmable LED light source.
Collezione di lampade a sospensione in alluminio. Disponibile in vari colori e dimensioni. La sorgente luminosa è a LED integrato dimmerabile.

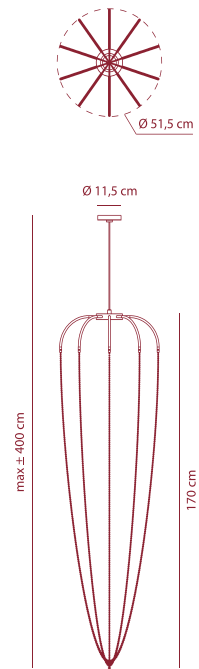

SP ALY 51 G

Source:
LED 20W - diffused beam - 3000K
 CRI 90 - ~1230 lm - 60 lm/W

CE IP20 dimmable DALI
 220-240VAC **LED**

COLOURS

- anthracite grey wrinkled/
chains: black polished nickel
- anthracite grey wrinkled/
chains: natural brass

SP ANA 150

Source:
E27 6 x Max 16W LED or
 6 x Max 20W fluo or
 6 x Max 70W halo

CE IP20 **+LED**

FLUO GX24q-4 6 x 42W

CE IP20 dimmable DALI

COLOURS

- ivory white

FINISH

- white canopy

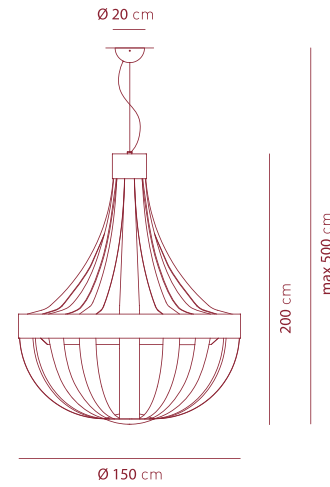

Aura

design Manuel Vivian

Collection consisting of wall lamps, ceiling lamps and suspended lamps with double-layered coloured Murano glass hand twisted pendants.

Collezione composta da lampade da parete, lampade da soffitto, lampade a sospensione, con pendenti in vetro di Murano colorato incamiciato cristallo e ritorti a mano.

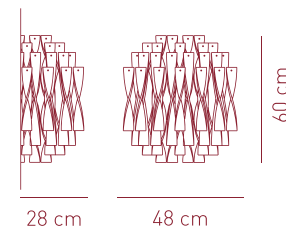

AP AURA

Source:
E27 2 x Max 20W LED or
 2 x Max 30W fluo or
 2 x Max 100W halo

CE IP20 **+LED**

COLOURS

- "rigadin" crystal
- red
- white
- tea

FINISH

- polished chrome
- gold leaf

Anadem

design Vanessa Vivian

Collection consisting of suspended lamps in flame-retardant eco-leather finish. Available in several colours and sizes. Screw fitting light source.

Collezione di lampade a sospensione con finitura in ecopelle ignifuga. Disponibile in vari colori e dimensioni. Sorgente luminosa con attacco a vite.

COMPOSITION/COMPOSIZIONE

Flame retardant Eco-leather - 87% PVC + 13% polyester
 Extra smooth flame retardant pongé fabric - 100% polyester

Tessuto ignifugato pongé superliscio - 100% poliestere
 Eco pelle ignifuga - 87% PVC + 13% poliestere

Glow Wire Test (EN 60598-1): 960°C

WEIGHT/PESO

550 ± 5% gr/m²

AVAILABLE UPON REQUEST

- brown
- red
- brown+white

SP ANA 090

Source:
E27 4 x Max 16W LED or
 4 x Max 20W fluo or
 4 x Max 70W halo

CE IP20 **+LED**

FLUO GX24q-4 4 x 42W

CE IP20 dimmable DALI

COLOURS

- ivory white

FINISH

- white canopy

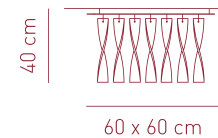
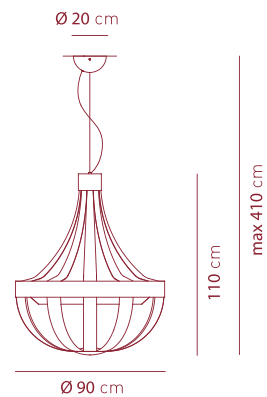

PL AUR P 30

Source:
E27 4 x Max 20W LED or
 4 x Max 30W fluo or
 4 x Max 100W halo

CE IP20 **+LED**

COLOURS

- "rigadin" crystal
- red
- white
- tea

FINISH

- polished chrome
- gold leaf

Aura

design Manuel Vivian

Collection consisting of wall lamps, ceiling lamps and suspended lamps with double-layered coloured Murano glass hand twisted pendants.

Collezione composta da lampade da parete, lampade da soffitto, lampade a sospensione, con pendenti in vetro di Murano colorato incamiciato cristallo e ritorti a mano.

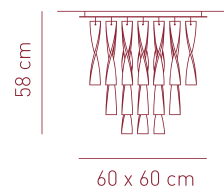

PL AURA P

Source:
E27 4 x Max 20W LED or
 4 x Max 30W fluo or
 4 x Max 100W halo

CE IP20 +LED

COLOURS



FINISH

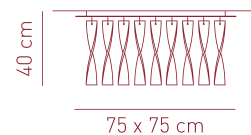
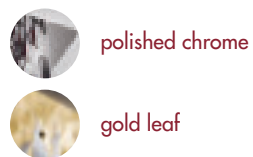

PL AUR G 30

Source:
E27 4 x Max 20W LED or
 4 x Max 30W fluo or
 4 x Max 100W halo

CE IP20 +LED

COLOURS



FINISH

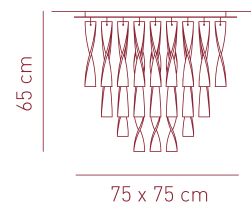
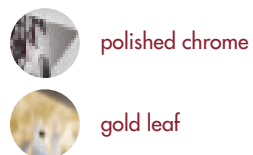

PL AURA GR

Source:
E27 4 x Max 20W LED or
 4 x Max 30W fluo or
 4 x Max 100W halo

CE IP20 +LED

COLOURS



FINISH

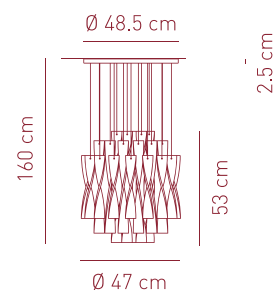
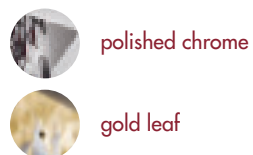

SP AURA 45

Source:
E27 1 x Max 27W LED or
 1 x Max 40W fluo or
 1 x Max 150W halo

CE IP20 +LED

COLOURS



FINISH

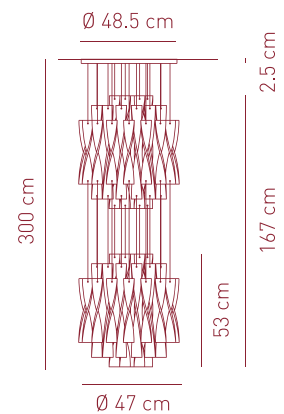

SP AU 45/2

Source:
E27 2 x Max 20W LED or
 2 x Max 23W fluo or
 2 x Max 150W halo

CE IP20 +LED

COLOURS



FINISH

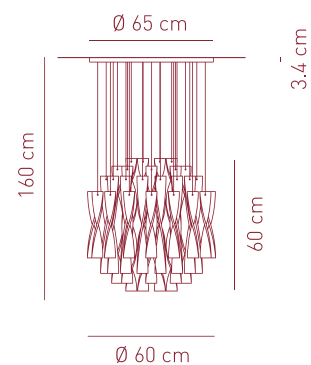

SP AURA 60

Source:
E27 1 x Max 35W LED or
 1 x Max 60W fluo or
 1 x Max 250W halo

CE IP20 +LED

COLOURS



FINISH

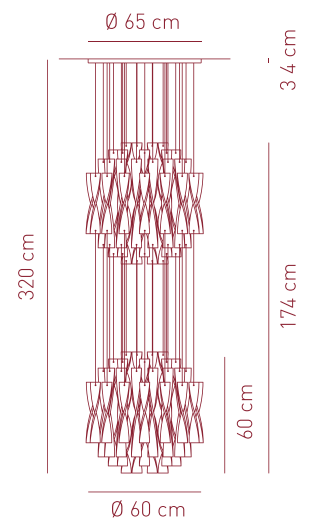

SP AURA 60/2

Source:
E27 2 x Max 20W LED or
 2 x Max 23W fluo or
 2 x Max 250W halo

CE IP20 +LED

COLOURS



FINISH



Ax 20

design Manuel Vivian

Collection consisting of wall lamps, suspended lamps, floor lamps and table lamps with chrome-plated finish.

Collezione composta da lampade da parete, lampade a sospensione, lampade da terra e da tavolo in metallo cromato.

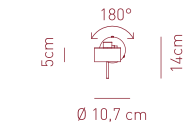
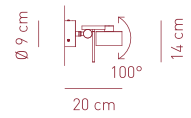

AP AX20 PI

COLOUR

Source:
G9 1 x Max 60W halo

● chrome

CE IP20

AP AX20 GR

COLOUR

Source:
G9 1 x Max 60W halo

● chrome

CE IP20

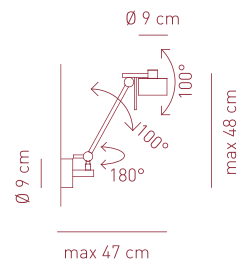

SP AX20 PI

COLOUR

Source:
G9 1 x Max 60W halo

● chrome

CE IP20

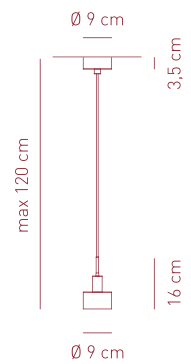

PT AX20

COLOUR

Source:
G9 1 x Max 60W halo

● chrome

CE IP20 dimmable

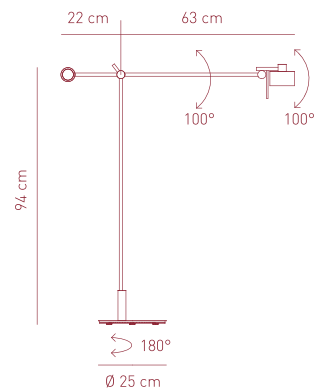

LT AX20

COLOUR

Source:
G9 1 x Max 60W halo

● chrome

CE IP20 dimmable

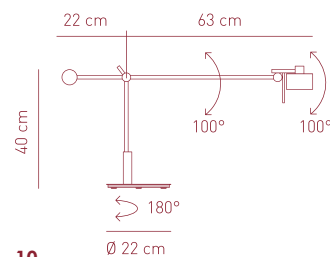

Bell

design Manuel Vivian

Collection consisting of ceiling lamps and suspended lamps with a metal frame covered with strips of extra smooth flame-retardant pongé fabric. Available in several colours and sizes. Screw fitting or built-in dimmable LED light source.

Collezione di lampade da soffitto e lampade a sospensione con struttura metallica rivestita con fettuccia di tessuto ignifugato pongé superliscio. Disponibile vari colori e dimensioni. Sorgente luminosa con attacco a vite o a LED integrato dimmerabile.

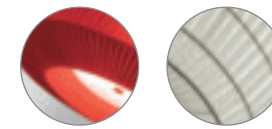

COMPOSITION/COMPOSIZIONE

Extra smooth flame retardant pongé fabric - 100% polyester
Tessuto ignifugato pongé superliscio - 100% poliestere

Glow Wire Test (EN 60598-1): 960°C

WEIGHT/PESO
55 ± 5% gr/m²

AVAILABLE UPON REQUEST



PL BEL 060

COLOURS

Source:
E27 2 x Max 16W LED or
2 x Max 23W fluo or
2 x Max 57W halo

○ white

CE IP20 +LED

Diffuser included

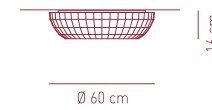

PL BEL 090

COLOURS

Source:
E27 3 x Max 16W LED or
3 x Max 23W fluo or
3 x Max 57W halo

○ white

CE IP20 +LED

Diffuser included

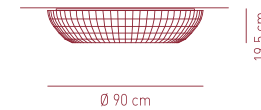

PL BEL 118

COLOURS

Source:
E27 4 x Max 16W LED or
4 x Max 23W fluo or
4 x Max 57W halo

○ white

CE IP20 +LED

Diffuser included

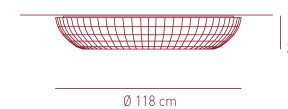

PL BEL 180

COLOURS

Source:
E27 5 x Max 16W LED or
5 x Max 23W fluo or
5 x Max 46W halo

○ white

CE IP20 +LED

Diffuser included

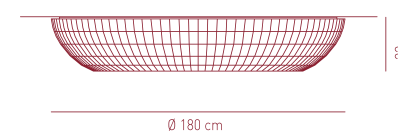

Bell

design Manuel Vivian

Collection consisting of ceiling lamps and suspended lamps with a metal frame covered with strips of extra smooth flame-retardant pongé fabric. Available in several colours and sizes. Screw fitting or built-in dimmable LED light source.

Collezione di lampade da soffitto e lampade a sospensione con struttura metallica rivestita con fettuccia di tessuto ignifugato pongé superliscio. Disponibile vari colori e dimensioni. Sorgente luminosa con attacco a vite o a LED integrato dimmerabile.

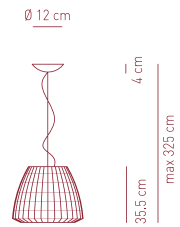

Ø 45 cm

SP BEL 045

COLOURS



Source:
E27 1 x Max 20W LED or
 1 x Max 33W fluo or
 1 x Max 70W halo

CE IP20 +LED

Diffuser not included

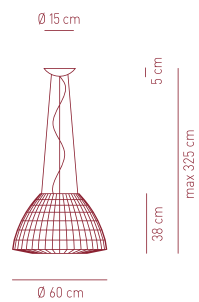

SP BEL 060

COLOURS



Source:
E27 1 x Max 20W LED or
 1 x Max 33W fluo or
 1 x Max 70W halo

CE IP20 +LED

Diffuser not included

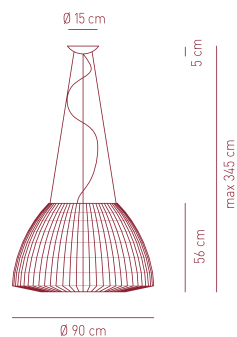

SP BEL 090

with upward & downward lighting

COLOURS



Source:
E27 4 x Max 20W LED or
 4 x Max 33W fluo or
 4 x Max 46W halo

CE IP20 +LED

Diffuser included

LED 75W - diffused beam - 3000K
 CRI 90 - ~6290 lm - 83 lm/W

CE IP20 dimmable DALI +LED

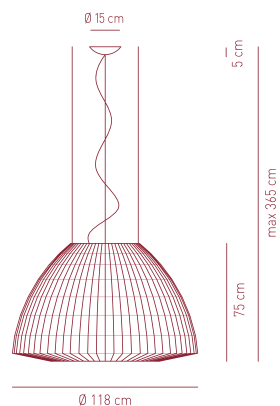

SP BEL 118

with upward & downward lighting

COLOURS



Source:
E27 4 x Max 20W LED or
 4 x Max 33W fluo or
 4 x Max 57W halo

CE IP20 +LED

Diffuser included

LED 95W - diffused beam - 3000K
 CRI 90 - ~6490 lm - 68 lm/W

CE IP20 dimmable DALI +LED

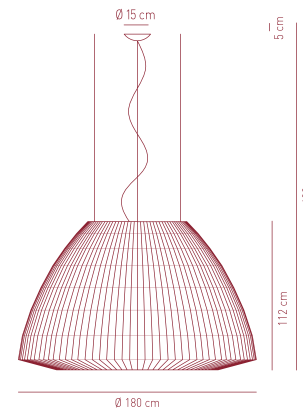

SP BEL 180

with upward & downward lighting

COLOURS



Source:
E27 4 x Max 16W + 1 x Max 9,5W LED or
 5 x Max 23W fluo or
 4 x Max 57W + 1 x Max 46W halo

CE IP20 +LED

Diffuser included

LED 95W - diffused beam - 3000K
 CRI 90 - ~5252 lm - 55 lm/W

CE IP20 dimmable DALI +LED

Clavius

design Manuel Vivian

Collection consisting of wall lamps, ceiling lamps, suspended lamps, table lamps and floor lamp. Metal frame and hand-made silken thread lampshade.

Collezione composta da lampade da parete, lampade da soffitto, lampade a sospensione, lampade da tavolo e lampada da terra con montatura in metallo e paralume lavorato a mano con fili setati.

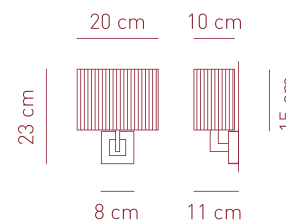

AP CLAV BR

COLOURS



Source:
E14 1 x Max 6,5W LED or
 1 x Max 12W fluo or
 1 x Max 42W halo

CE IP20 +LED

FINISH

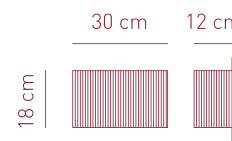
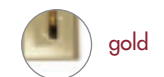

AP CLAV 30

COLOURS



Source:
E14 1 x Max 6,5W LED or
 1 x Max 12W fluo or
 1 x Max 42W halo

CE IP20 +LED

FINISH

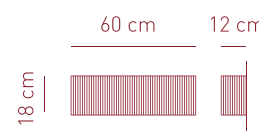

AP CLAV PI

COLOURS



Source:
E14 2 x Max 6,5W LED or
 2 x Max 12W fluo or
 2 x Max 42W halo

CE IP20 +LED

FINISH



Clavius

design Manuel Vivian

Collection consisting of wall lamps, ceiling lamps, suspended lamps, table lamps and floor lamp. Metal frame and hand-made silken thread lampshade.

Collezione composta da lampade da parete, lampade da soffitto, lampade a sospensione, lampade da tavolo e lampada da terra con montatura in metallo e paralume lavorato a mano con fili setati.



AP CLAV GR

Source:
E14 6 x Max 6,5W LED or
 6 x Max 12W fluo or
 6 x Max 42W halo

CE IP20 +LED

Diffuser included

COLOURS



FINISH

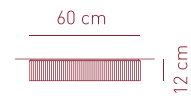

PL CLAVIU

Source:
E27 3 x Max 9,5W LED or
 3 x Max 12W fluo or
 3 x Max 46W halo

CE IP20 +LED

Diffuser included

COLOURS

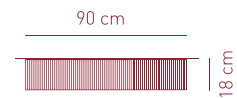

PL CLAV 90

Source:
E27 3 x Max 16W LED or
 3 x Max 23W fluo or
 3 x Max 70W halo

CE IP20 +LED

Diffuser included

COLOURS

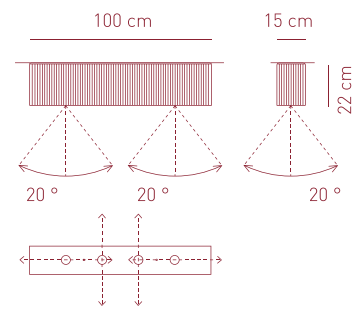

PL CLA 100

Source:
LED 4 x 10,2W - 40° - 2700K
 CRI 80 - ~4 x ~1015 lm - 99 lm/W

CE IP20 - dimmable + LED

COLOURS

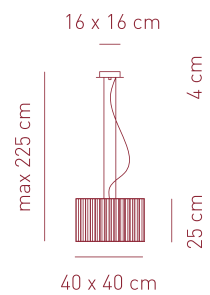

SP CLAV 40

Source:
E27 4 x Max 6,5W LED or
 4 x Max 12W fluo or
 4 x Max 46W halo

CE IP20 +LED

COLOURS



FINISH

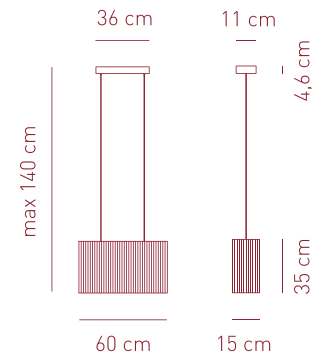
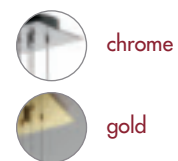

SP CLAVI P

Source:
E27 2 x Max 16W LED or
 2 x Max 21W fluo or
 2 x Max 70W halo

CE IP20 +LED

Diffuser included

COLOURS



FINISH

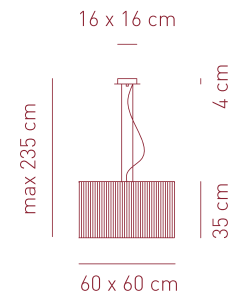
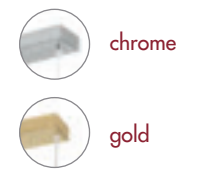

SP CLAV 60

Source:
E27 4 x Max 16W LED or
 4 x Max 21W fluo or
 4 x Max 70W halo

CE IP20 +LED

Diffuser included

COLOURS



FINISH

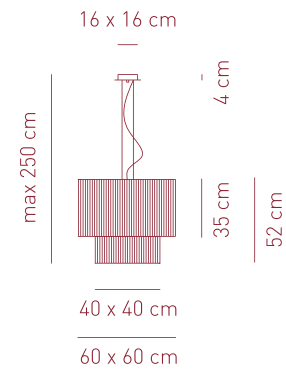
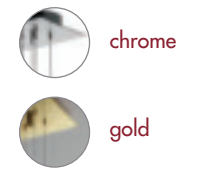

SP CL 60 40

Source:
E27 4 x Max 16W LED or
 4 x Max 21W fluo or
 4 x Max 70W halo

CE IP20 +LED

Diffuser included

COLOURS



FINISH

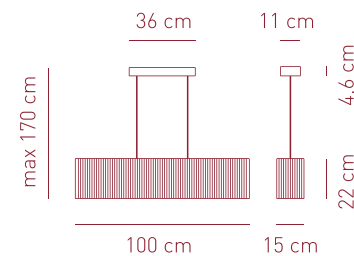
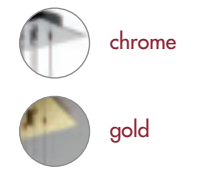

SP CLAVIU LED

Source:
LED 34,2W - 2700K
 CRI 80 - ~3470 lm - 101 lm/W

CE IP20 - dimmable DALI + LED

Diffuser not included (optional)

COLOURS



FINISH

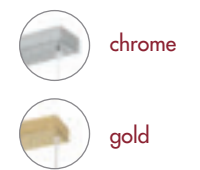

Clavius

design Manuel Vivian

Collection consisting of wall lamps, ceiling lamps, suspended lamps, table lamps and floor lamp. Metal frame and hand-made silken thread lampshade.

Collezione composta da lampade da parete, lampade da soffitto, lampade a sospensione, lampade da tavolo e lampada da terra con montatura in metallo e paralume lavorato a mano con fili setati.

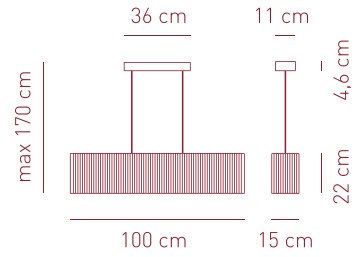

SP CLAVIU FLE

Source:
FLUO G5 1 x 39W

CE IP20

Diffuser not included (optional)

COLOURS

white tobacco

sand

FINISH

chrome

gold

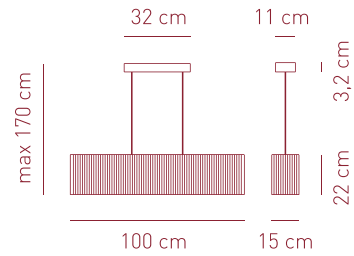

SP CLAVIU E27

Source:
E27 3 x Max 16W LED or
3 x Max 21W fluo or
3 x Max 70W halo

CE IP20 +LED

Diffuser not included (optional)

COLOURS

white tobacco

sand

FINISH

chrome

gold

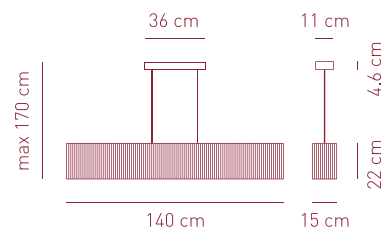

SP CLA 140 LED

Source:
LED 45,6W - 2700K
CRI 80 - ~4626 lm - 101 lm/W

CE IP20 dimmable DALI +LED

Diffuser not included (optional)

COLOURS

white tobacco

sand

FINISH

chrome

gold

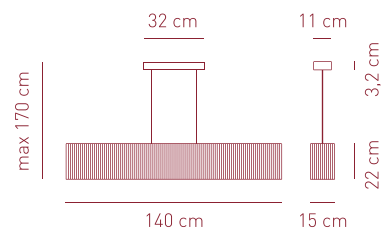

SP CLA 140 E27

Source:
E27 4 x Max 16W LED or
4 x Max 21W fluo or
4 x Max 70W halo

CE IP20 +LED

COLOURS

white tobacco

sand

FINISH

chrome

gold

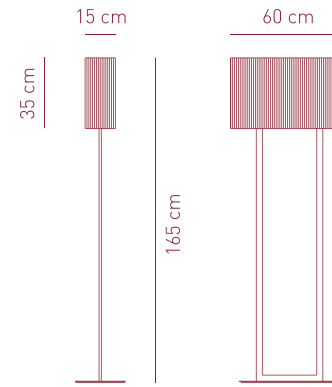

PT CLAVIU

Source:
E27 2 x Max 16W LED or
2 x Max 21W fluo or
2 x Max 70W halo
(dimmable lamps required)

CE IP20 dimmable +LED

COLOURS

white tobacco

sand

FINISH

chrome

gold

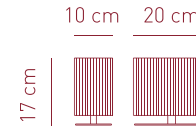

LT CLAV XP

Source:
E14 1 x Max 6,5W LED or
1 x Max 12W fluo or
1 x Max 42W halo

CE IP20 +LED

COLOURS

white tobacco

sand

FINISH

chrome

gold

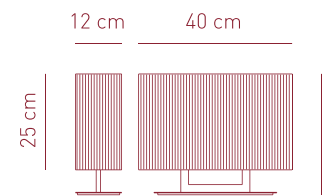

LT CLAVI P

Source:
E14 2 x Max 6,5W LED or
2 x Max 12W fluo or
2 x Max 42W halo

CE IP20 +LED

COLOURS

white tobacco

sand

FINISH

chrome

gold

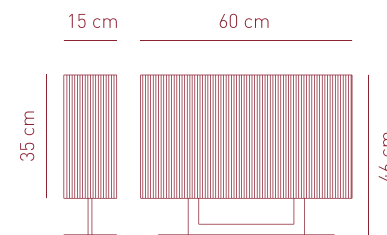

LT CLAVI G

Source:
E27 2 x Max 16W LED or
2 x Max 21W fluo or
2 x Max 70W halo

CE IP20 +LED

COLOURS

white tobacco

sand

FINISH

chrome

gold

Crystal spotlight

design Manuel Vivian

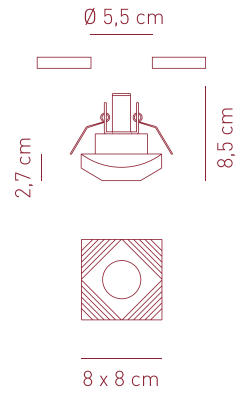

Crystal recessed downlight with metal finish.
Light source with 12V GY6.35, GU4 fitting, or G9 fitting.
Faretto ad incasso in cristallo. Sorgente luminosa con attacco GY6.35 o GU4 a 12V oppure con attacco G9.

FA MENCAR

COLOUR

Source:
G9 1 x Max 40W halo 220-240VAC  crystal
 

Source:
GY6.35 1 x Max 35W 12VAC or
GU4 1 x Max 35W 12VAC dicr.

   with dedicated PSU

for transformer and dimming technology, please refer to our Axo Light pricelist or contact our representatives

hole \varnothing 5.5 cm
min depth 10 cm

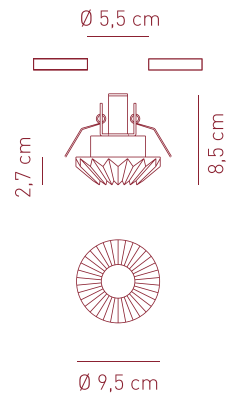

FA NASHIR

COLOUR

Source:
G9 1 x Max 40W halo 220-240VAC  crystal
 

Source:
GY6.35 1 x Max 35W 12VAC or
GU4 1 x Max 35W 12VAC dicr.

   with dedicated PSU

for transformer and dimming technology, please refer to our Axo Light pricelist or contact our representatives

hole \varnothing 5.5 cm
min depth 10 cm

Euler

design Cambi - Scatena - Turini

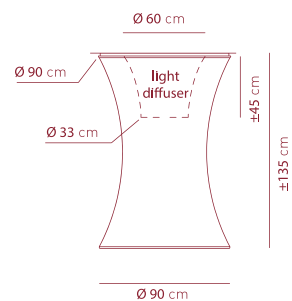



Collection of ceiling lamps made in white stretch fabric.
Collezione di lampade da soffitto in tessuto elastico bianco.

COMPOSITION/COMPOSIZIONE
Synthetic fabric / Polyamide 92% + Elastan 8%
Tessuto sintetico / Poliammide 92% + Elastan 8%
Colore / Colour Pantone star white 11-4202 TPX
Glow Wire test (EN 60598-1): 750°C

WEIGHT/PESO
70 gr/m²

PL EULER P

COLOUR

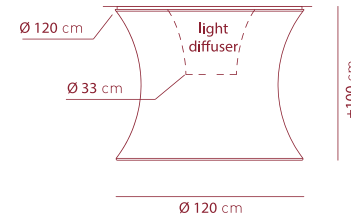

Source:
FLUO GX24q-4 4 x 42W
  

 white



PL EULER M

COLOUR

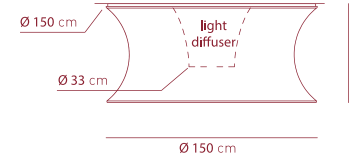

Source:
FLUO GX24q-4 4 x 42W
  

 white



PL EULER G

COLOUR

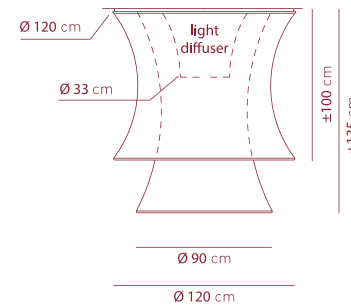

Source:
FLUO GX24q-4 4 x 42W
  

 white



PL EULER MP

COLOUR

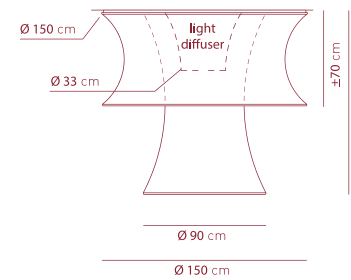

Source:
FLUO GX24q-4 4 x 42W
  

 white



PL EULER GP

COLOUR

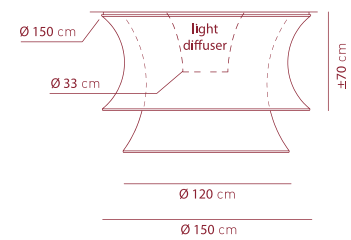

Source:
FLUO GX24q-4 4 x 42W
  

 white



PL EULER GM

COLOUR

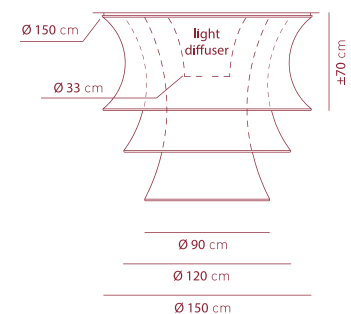

Source:
FLUO GX24q-4 4 x 42W
  

 white



PL EULER GMP

COLOUR

Source:
FLUO GX24q-4 4 x 42W
  

 white

Explo

design Manuel Vivian

Collection of suspended lamps with painted metal and steel frame and with hand-made Murano glass bars. Light source with R7s fitting. Customised compositions are possible upon request.

Collezione di lampade a sospensione con montatura verniciata e acciaio, con barre in vetro di Murano lavorate a mano. Sorgente luminosa con attacco R7s. Possibilità di composizioni personalizzate.

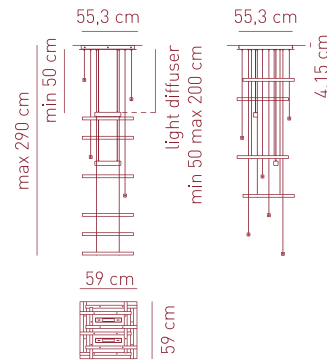

SP EXP Q10
Source:
R7S 2 x Max 120W (118)
CE **IP20**

COLOURS
 ○ white ● red

FINISH
 white and steel

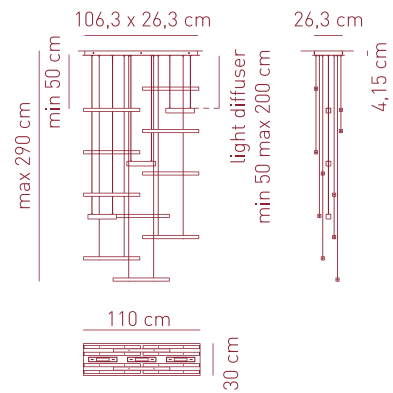

SP EXPL 10
Source:
R7S 3 x Max 120W (118)
CE **IP20**

COLOURS
 ○ white ● red

FINISH
 white and steel

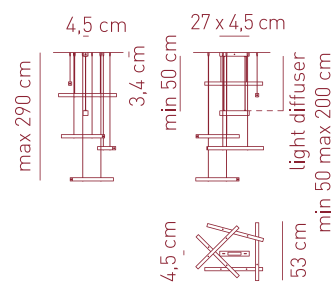

SP EXPLO 5
Source:
R7S 1 x Max 120W (118)
CE **IP20**

COLOURS
 ○ white ● red

FINISH
 white and steel

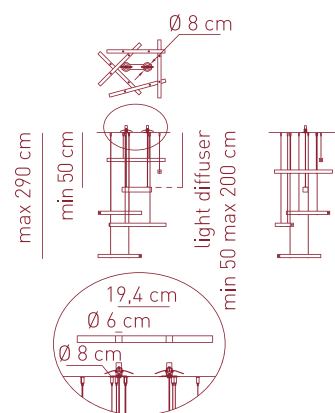

SP EXPL I 5
Source:
R7S 1 x Max 120W (118)
CE **IP20**
 hole Ø 6 cm
 min depth 10 cm

COLOURS
 ○ white ● red

FINISH
 white and steel

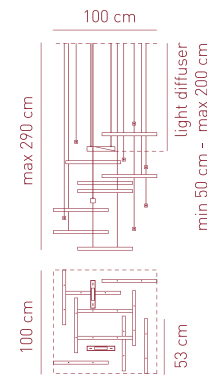

SP EXPL I 5
100X100 COMPOSITION
 customised composition example
 15 glass bars & 2 light diffusers

Source:
R7S 2 x Max 120W (118)
CE **IP20**

hole Ø 6 cm
 min depth 10 cm

COLOURS
 ○ white ● red

FINISH
 white and steel

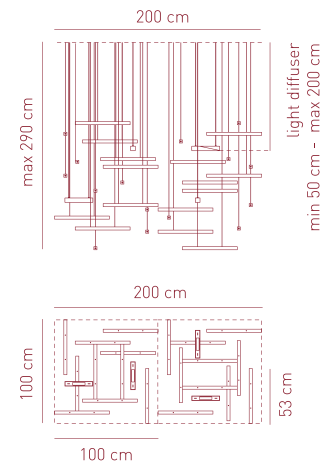

SP EXPL I 5
200X100 COMPOSITION
 customised composition example
 30 glass bars & 4 light diffusers

Source:
R7S 4 x Max 120W (118)
CE **IP20**

hole Ø 6 cm
 min depth 10 cm

COLOURS
 ○ white ● red

FINISH
 white and steel

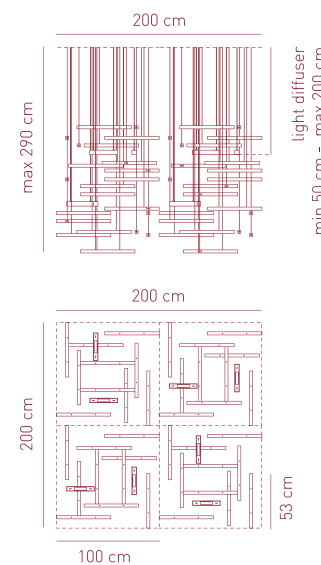

SP EXPL I 5
200X200 COMPOSITION
 customised composition example
 60 glass bars & 8 light diffusers

Source:
R7S 8 x Max 120W (118)
CE **IP20**

hole Ø 6 cm
 min depth 10 cm

COLOURS
 ○ white ● red

FINISH
 white and steel

Fairy

design Manuel Vivian

Collection consisting of recessed downlights, wall lamps, ceiling lamps and suspended lamps with chromed metal frame and glass diffuser.
Collezione composta da faretti, lampade da parete, lampade da soffitto e lampade a sospensione con struttura in metallo e diffusore in cristallo.

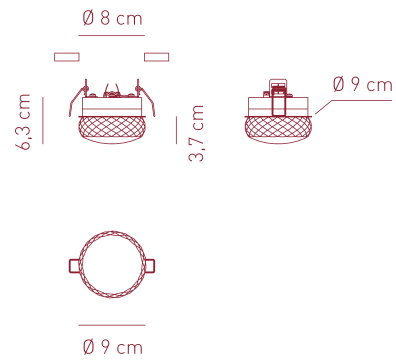

FA FAIRY

Source:
LED 6,2W - 350mA - diffused beam
 - 2700K
 CRI 90 - ~478 lm - 77 lm/W



hole \varnothing 5.5 cm /
 min depth 10 cm

DIFFUSER COLOURS



FINISH

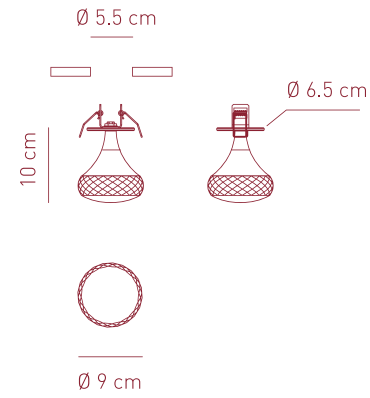
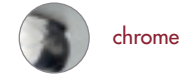

PL FAIRY I recessed

Source:
LED 6,2W - 350mA - diffused beam
 - 2700K
 CRI 90 - ~478 lm - 77 lm/W



driver not included

for drivers and dimming technology,
 please refer to our Axo Light pricelist
 or contact our representatives

hole \varnothing 5.5 cm
 min depth 10 cm

DIFFUSER COLOURS



FINISH

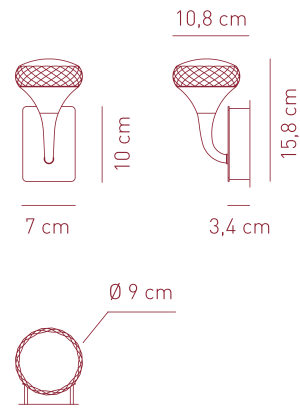

AP FAIRY

Source:
LED 6,2W - diffused beam - 2700K
 CRI 90 - ~478 lm - 77 lm/W



DIFFUSER COLOURS



FINISH

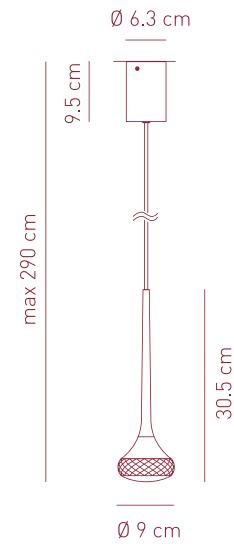
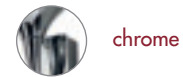

SP FAIRY

Source:
LED 6,2W - diffused beam - 2700K
 CRI 90 - ~478 lm - 77 lm/W



DIFFUSER COLOURS

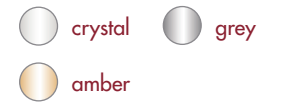

FINISH

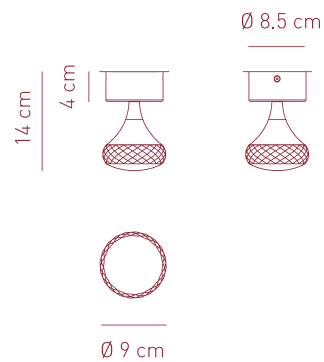

PL FAIRY

Source:
LED 6,2W - diffused beam - 2700K
 CRI 90 - ~478 lm - 77 lm/W



DIFFUSER COLOURS

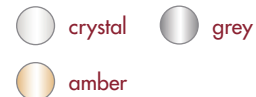

FINISH

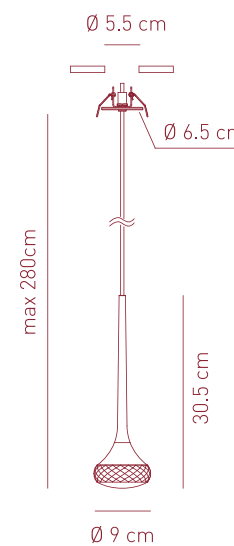

SP FAIRY I

Source:
LED 6,2W - 350mA - diffused beam
 - 2700K
 CRI 90 - ~478 lm - 77 lm/W



driver not included

for drivers and dimming technology,
 please refer to our Axo Light pricelist
 or contact our representatives

hole \varnothing 5.5 cm
 min depth 10 cm

DIFFUSER COLOURS

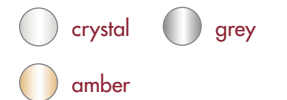

FINISH



Fairy

design Manuel Vivian

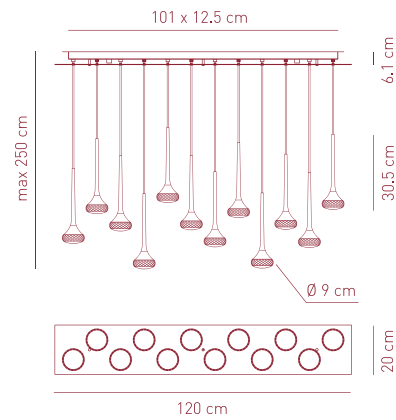

Collection consisting of recessed downlights, wall lamps, ceiling lamps and suspended lamps with chromed metal frame and glass diffuser.
Collezione composta da faretti, lampade da parete, lampade da soffitto e lampade a sospensione con struttura in metallo e diffusore in cristallo.

SP FAI 12 R

Source:
LED 12 x 6,2W - diffused beam - 2700K
 CRI 90 - 12x ~478 lm - 77 lm/W



DIFFUSER COLOURS

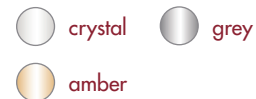

FINISH

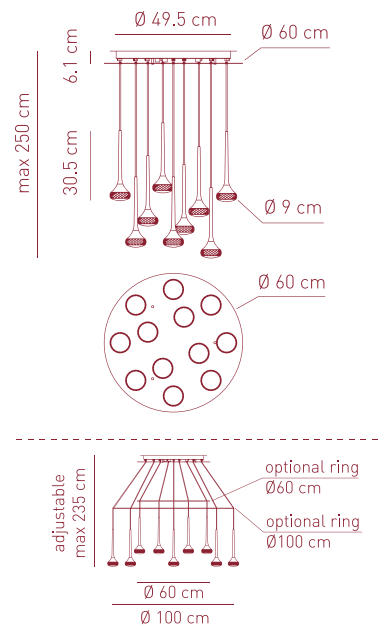
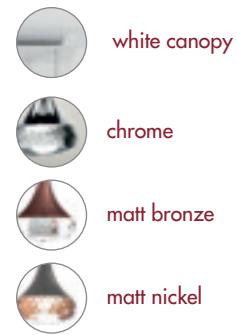

SP FAIR 12

Source:
LED 12 x 6,2W - diffused beam - 2700K
 CRI 90 - 12x ~478 lm - 77 lm/W



DIFFUSER COLOURS

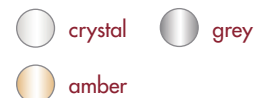

FINISH

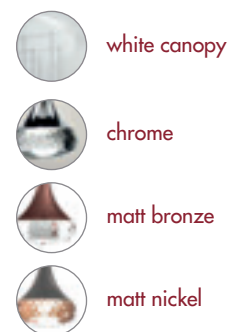

Ring for customised composition optional

We suggest the use of both the Ø 60 cm and Ø 100 cm rings together when creating customised compositions

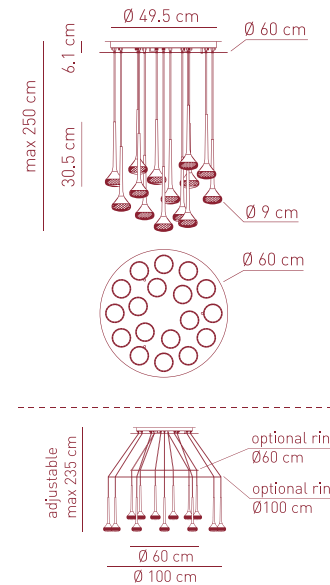

SP FAIRY 18

Source:
LED 18 x 6,2W - diffused beam
 - 2700K
 CRI 90 - 18 x ~478 lm - 77 lm/W

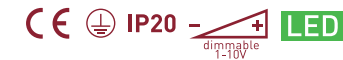

DIFFUSER COLOURS



FINISH



Ring for customised composition optional

We suggest the use of both the Ø 60 cm and Ø 100 cm rings together when creating customised compositions

Favilla

design Manuel Vivian

Collection consisting of adjustable wall or ceiling lamps in aluminium, also in a recessed version.
Collezione composta da lampada da parete o da soffitto in alluminio in vari colori, orientabile. Disponibile anche nella versione ad incasso.

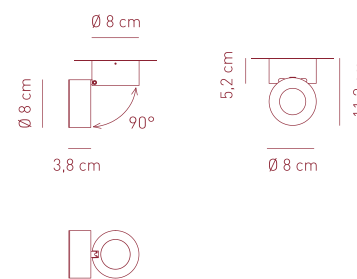

FAVILLA WALL/CEILING/SPOT

Source:
LED
 22° or 45° beam

6,2W: CRI 90 - ~437 lm - 70 lm/W - 2700K

8,4W: CRI 80 - ~594 lm - 70 lm/W - 4000K



COLOURS

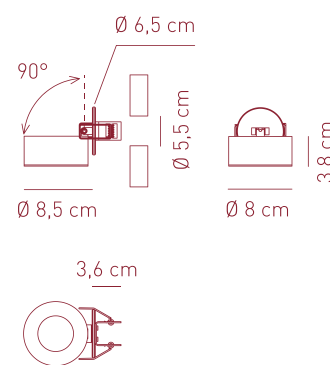

FAVILLA RECESSED

Source:
LED
 350mA - 22° or 45° beam

6,2W: CRI 90 - ~437 lm - 70 lm/W - 2700K



driver not included

for drivers and dimming technology, please refer to our Axo Light pricelist or contact our representatives

hole Ø 5.5 cm
 min depth 10 cm

COLOURS



Fedora

design Dima Loginoff

Collection consisting of recessed downlight and suspended lamps.
Collezione composta da faretto ad incasso e lampade a sospensione.

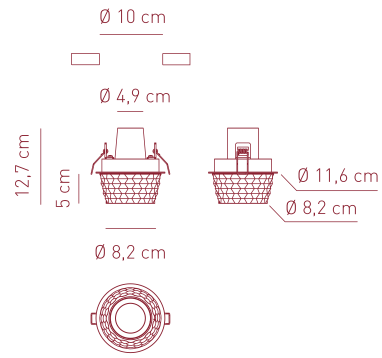

FA FEDORA

Source:
GU10 LED 1 x Max 7,5W
only LED bulb 220-240VAC

CE IP20 LED

hole \varnothing 10 cm
min depth 10 cm

COLOURS



glass

FINISH



white varnished metal

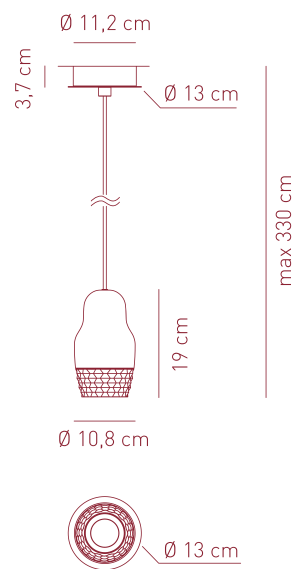

SP FEDOR 1

Source:
GU10 LED 1 x Max 7,5W
only LED bulb 220-240VAC

CE IP20 LED

hole \varnothing 10 cm
min depth 10 cm

COLOURS



rose gold+glass



bronze+glass



chrome+glass

FINISH



white varnished metal

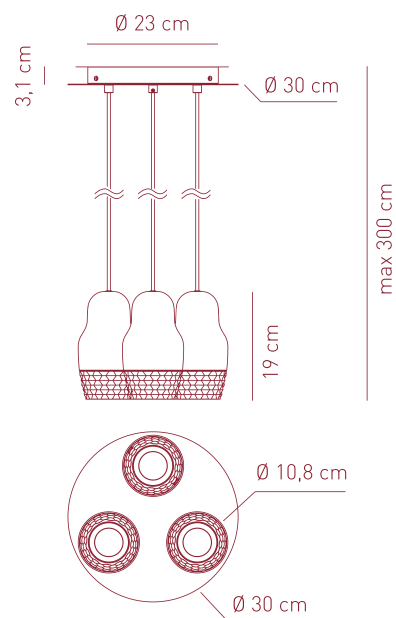

SP FEDOR 3

Source:
GU10 LED 3 x Max 7,5W
only LED bulbs 220-240VAC

CE IP20 LED

COLOURS



rose gold+glass



bronze+glass



chrome+glass

FINISH



white varnished metal

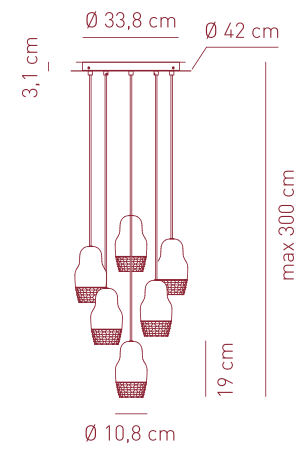

SP FEDOR 6

Source:
GU10 LED 6 x Max 7,5W
only LED bulbs 220-240VAC

CE IP20 LED

COLOURS



rose gold+glass



bronze+glass



chrome+glass

FINISH



white varnished metal

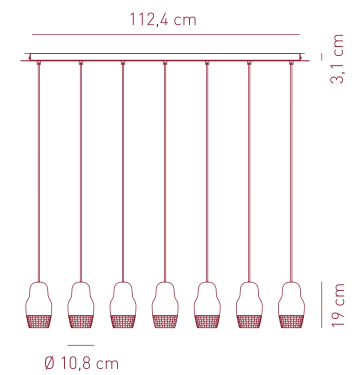
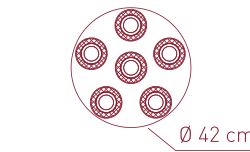

SP FEDOR 7

Source:
GU10 LED 7 x Max 7,5W
only LED bulbs 220-240VAC

CE IP20 LED

COLOURS



rose gold+glass



bronze+glass



chrome+glass

FINISH



white varnished metal

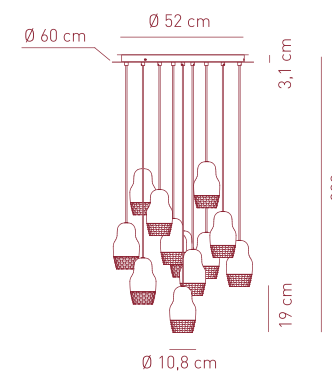
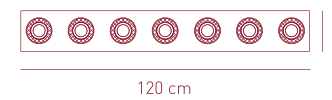

SP FEDO 12

Source:
GU10 LED 12 x Max 7,5W
only LED bulbs 220-240VAC

CE IP20 LED

COLOURS



rose gold+glass



bronze+glass



chrome+glass

FINISH



white varnished metal

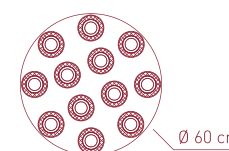

Framework LED

design Manuel Vivian



Collection consisting of ceiling or wall lamps and suspended lamps in white aluminium. Available in several sizes. The ceiling/wall lamps are also supplied in three different heights. Built-in LED light source.

Collezione di lampade da soffitto o da parete e lampade a sospensione in alluminio bianco. Disponibile in varie dimensioni. Le lampade da soffitto/da parete sono fornite in tre diverse altezze. Sorgente luminosa a LED integrato dimmerabile.

FINISH/FINITURA

Wrinkled-white aluminium

Alluminio verniciato bianco raggrinzato

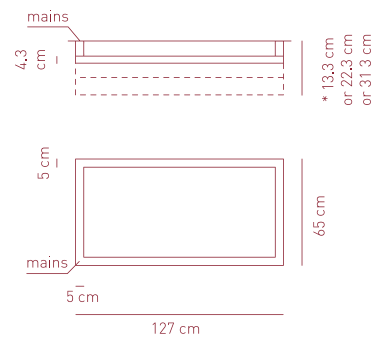

PL FW P 090/180/270
application: both as ceiling or wall lamp

COLOUR

wrinkled white aluminium

Source:

LED 65,6W - diffused beam - 3000K
CRI 80 - ~8824 lm - 134,5 lm/W

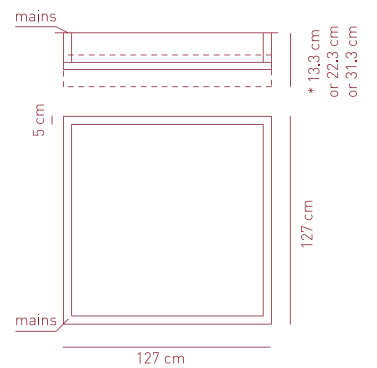

PL FW M 090/180/270
application: both as ceiling or wall lamp

COLOUR

wrinkled white aluminium

Source:

LED 65,6W - diffused beam - 3000K
CRI 80 - ~8824 lm - 134,5 lm/W

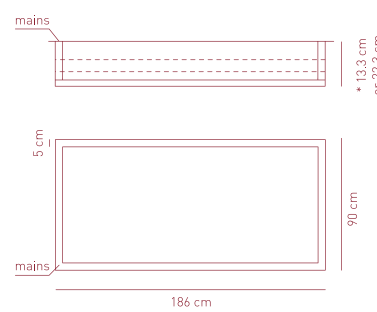

PL FW G 090/180/270
application: both as ceiling or wall lamp

COLOUR

wrinkled white aluminium

Source:

LED 98,4W - diffused beam - 3000K
CRI 80 - ~13236 lm - 131 lm/W

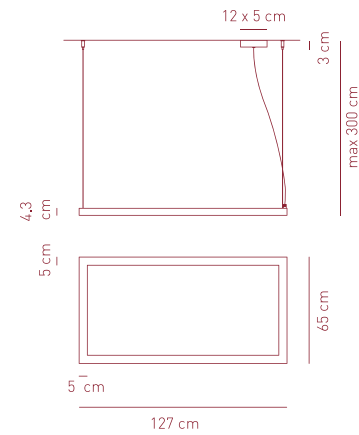

SP FRAME P

Source:

LED 65,6W - diffused beam - 3000K
CRI 80 - ~8824 lm - 134,5 lm/W



COLOUR

wrinkled white aluminium

white canopy

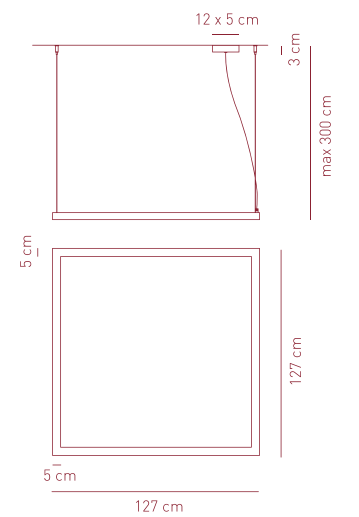

SP FRAME M

Source:

LED 65,6W - diffused beam - 3000K
CRI 80 - ~8824 lm - 134,5 lm/W



COLOUR

wrinkled white aluminium

white canopy

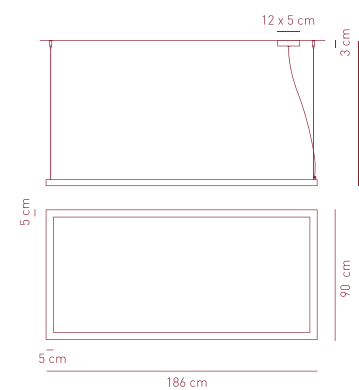

SP FRAME G

Source:

LED 98,4W - diffused beam - 3000K
CRI 80 - ~13236 lm - 131 lm/W

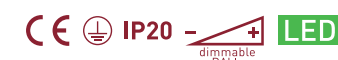

COLOUR

wrinkled white aluminium

white canopy

*Available heights



PL FW P/M/G 090

PL FW P/M/G 180

PL FW P/M/G 270

diffuser

Hoops

design Giovanni Barbato

Collection consisting of ceiling lamps and suspended lamps with interchangeable elements in different shapes and sizes. Gold finish. Built-in dimmable LED light source. The suspended lamps can light upward and downward.

Collezione composta da lampade da soffitto e lampade a sospensione con elementi intercambiabili di diverse forme e dimensioni. Finitura dorata. Sorgente luminosa a LED integrato dimmerabile. Le lampade a sospensione prevedono un'illuminazione uplight e downlight.

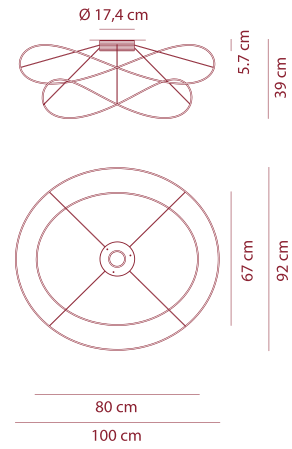

PL HOOPS 2

Source:

LED 16,6W - diffused beam - 3000K
CRI 90 - ~1210 lm - 73 lm/W



220-240VAC

LED

COLOUR

gold

FINISH

gold finish

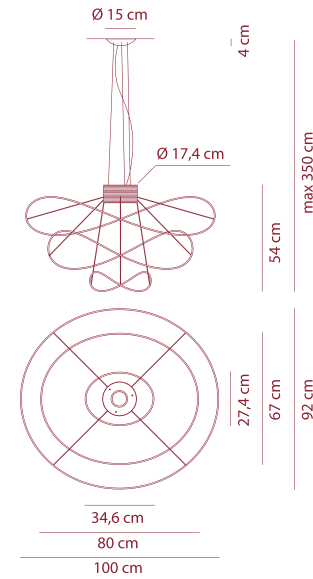

SP HOOPS 3

with upward & downward light

Source:

LED 33,2W - diffused beam - 3000K
CRI 90 - ~2420 lm - 73 lm/W



220-240VAC

LED

COLOUR

gold

FINISH

gold finish

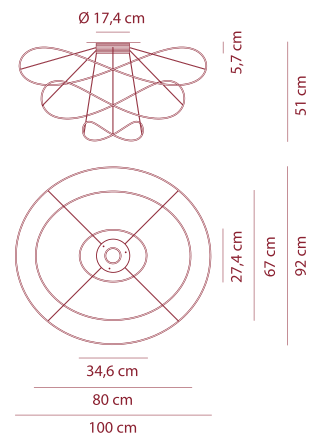

PL HOOPS 3

Source:

LED 16,6W - diffused beam - 3000K
CRI 90 - ~1210 lm - 73 lm/W



220-240VAC

LED

COLOUR

gold

FINISH

gold finish

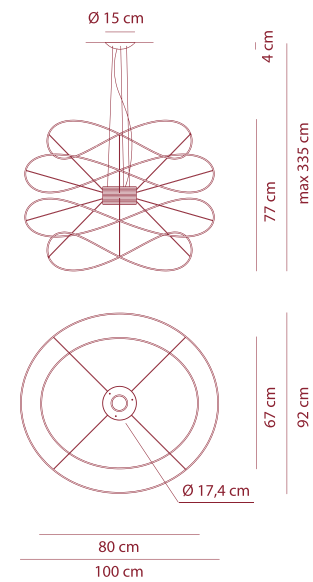

SP HOOPS 4

with upward & downward light

Source:

LED 33,2W - diffused beam - 3000K
CRI 90 - ~2420 lm - 73 lm/W



220-240VAC

LED

COLOUR

gold

FINISH

gold finish

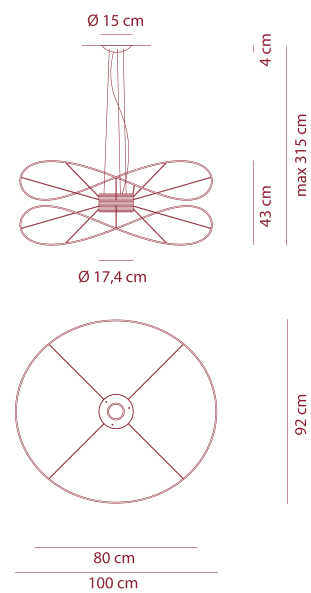

SP HOOPS 2

with upward & downward light

Source:

LED 33,2W - diffused beam - 3000K
CRI 90 - ~2420 lm - 73 lm/W



220-240VAC

LED

COLOUR

gold

FINISH

gold finish

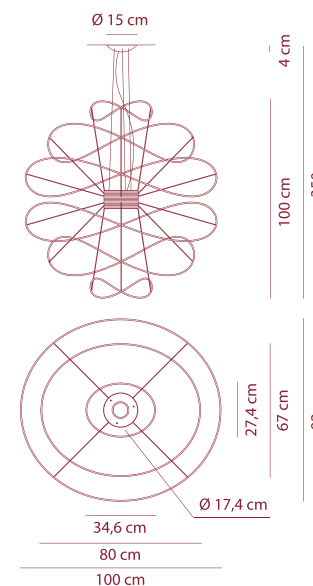

SP HOOPS 6

with upward & downward light

Source:

LED 33,2W - diffused beam - 3000K
CRI 90 - ~2420 lm - 73 lm/W



220-240VAC

LED

COLOUR

gold

FINISH

gold finish

Layers

design Vanessa Vivian



Collection consisting of suspended lamps with a metal frame covered with strips of extra smooth flame-retardant pongé fabric. Available in several colours and sizes. Screw fitting light source.

Collezione di lampade a sospensione con struttura metallica rivestita con fettuccia di tessuto ignifugato pongé superliscio. Disponibile vari colori e dimensioni. Sorgente luminosa con attacco a vite.

COMPOSIZIONE/COMPOSITION

Extra smooth flame retardant pongé fabric - 100% polyester

Tessuto ignifugato pongé superliscio - 100% poliestere

Glow Wire Test (EN 60598-1): 960°C

PESO/WEIGHT

55 ± 5% gr/m²

AVAILABLE UPON REQUEST

- orange
- warm white
- gold yellow
- light grey
- dark grey
- brick red
- burgundy
- red
- light green
- Multicolor 1: burgundy + red + orange + yellow
- Multicolor 2: dark grey + light grey + white

SP LAY A

Source:
E27 9 x Max 16W LED or
 9 x Max 20W fluo or
 9 x Max 70W halo

CE **IP20 +LED**

COLOUR

white

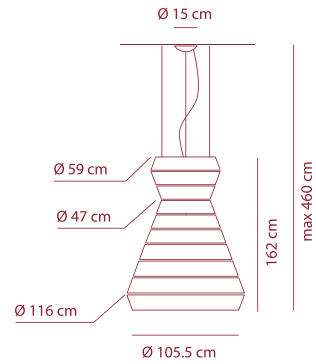

SP LAY B

Source:
E27 15 x Max 16W LED or
 15 x Max 20W fluo or
 15 x Max 70W halo

CE **IP20 +LED**

COLOUR

white

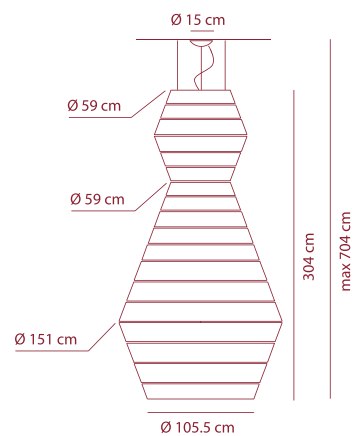

SP LAY C

Source:
E27 15 x Max 16W LED or
 15 x Max 20W fluo or
 15 x Max 70W halo

CE **IP20 +LED**

COLOUR

white

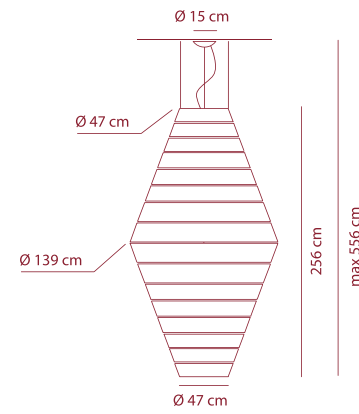

SP LAY D

Source:
E27 9 x Max 16W LED or
 9 x Max 20W fluo or
 9 x Max 70W halo

CE **IP20 +LED**

COLOUR

white

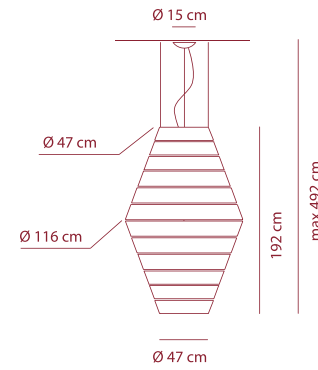

SP LAY E

Source:
E27 9 x Max 16W LED or
 9 x Max 20W fluo or
 9 x Max 70W halo

CE **IP20 +LED**

COLOUR

white

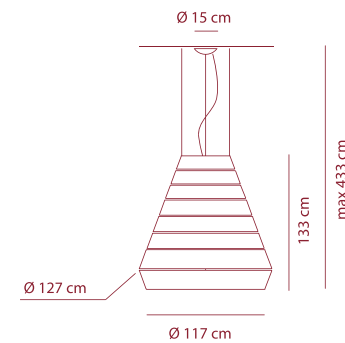

SP LAY F

Source:
E27 9 x Max 16W LED or
 9 x Max 20W fluo or
 9 x Max 70W halo

CE **IP20 +LED**

COLOUR

white

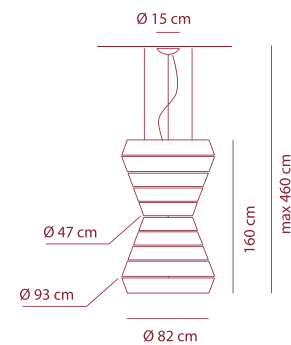

Lik

design Serge & Robert Cornelissen

Collection of aluminium wall lamps. Built-in dimmable LED light.
Lampada da parete in alluminio. Sorgente luminosa a LED integrato dimmerabile.

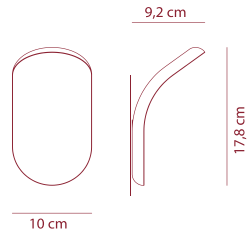

AP LIK

Source:
LED 16,6W - 3000K
CRI 90 - ~1350 lm - 81 lm/W



COLOURS

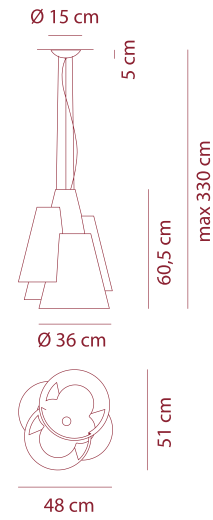

SP MELT 60

Source:
E27 1 x Max 16W LED or
1 x Max 23W fluo or
1 x Max 70W halo



Diffuser not included (optional)

COLOURS

light patterns:

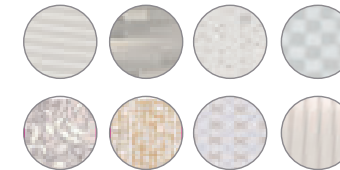

FINISH



dark patterns:



BC
light patterns outside/
white inside



BA
light patterns outside/
silver inside



BO
light patterns outside/
gold inside



NA
dark patterns outside/
silver inside

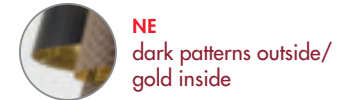

NE
dark patterns outside/
gold inside

Melting Pot

design Sandro Santantonio

Collection consisting of wall lamps, suspended lamps and floor lamps.
The lampshades coming in various decorative patterns.
Opalescent diffusers available on request. Screw fitting light source.
Collezione composta da lampade da parete, a sospensione e da terra.
I paralumi sono proposti con diversi pattern decorativi. Diffusori opalescenti disponibili su richiesta. Sorgente luminosa con attacco a vite.

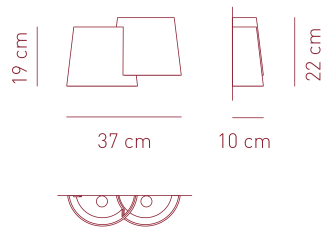

AP MELTIN

Source:
E27 2 x Max 16W LED or
2 x Max 15W fluo or
2 x Max 30W halo



COLOURS



light patterns:



BC
light patterns outside/
white inside



BO
light patterns outside/
gold inside

FINISH



white varnished metal



dark patterns:



NE
dark patterns outside/
gold inside

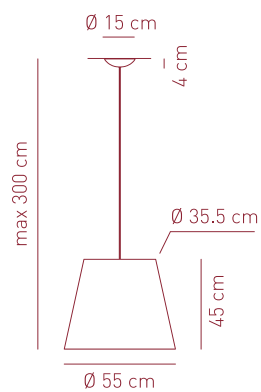

SP MELT 55

Source:
E27 3 x Max 16W LED or
3 x Max 15W fluo or
3 x Max 70W halo



Diffuser not included (optional)

COLOURS



light patterns:



BA
light patterns outside/
silver inside



BO
light patterns outside/
gold inside

FINISH



white canopy



dark patterns:



NA
dark patterns outside/
silver inside

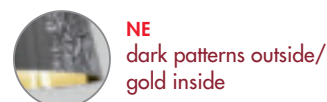

NE
dark patterns outside/
gold inside

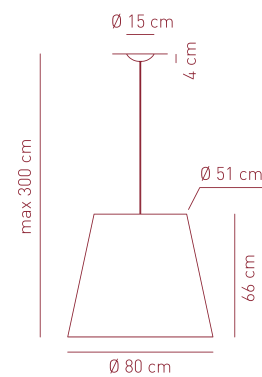

SP MELT 80

Source:
E27 3 x Max 16W LED or
3 x Max 15W fluo or
3 x Max 70W halo



Diffuser not included (optional)

COLOURS



light patterns:



BA
light patterns outside/
silver inside



BO
light patterns outside/
gold inside

FINISH



white canopy



dark patterns:



NA
dark patterns outside/
silver inside

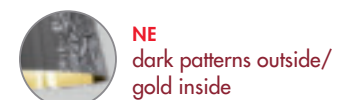

NE
dark patterns outside/
gold inside

Melting Pot

design Sandro Santantonio

Collection consisting of wall lamps, suspended lamps and floor lamps.
The lampshades coming in various decorative patterns.
Opalescent diffusers available on request.
Screw fitting light source.

Collezione composta da lampade da parete, a sospensione e da terra.
I paralumi sono proposti con diversi pattern decorativi.
Diffusori opalescenti disponibili su richiesta.
Sorgente luminosa con attacco a vite.

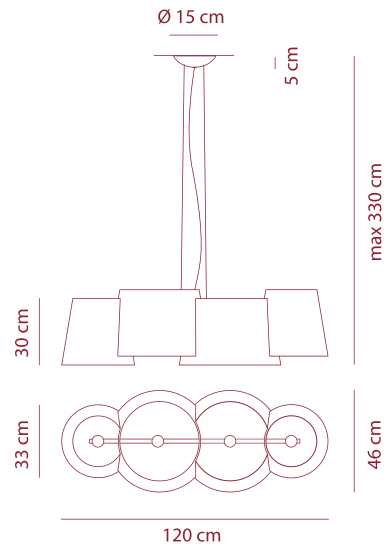

SP MEL 115

Source:
E27 4 x Max 16W LED or
4 x Max 23W fluo or
4 x Max 70W halo

CE **IP20 +LED**

Diffuser not included (optional)

COLOURS

light patterns:

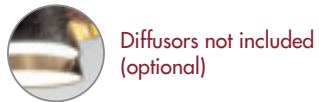
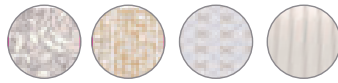

Diffusers not included (optional)

FINISH



dark patterns:

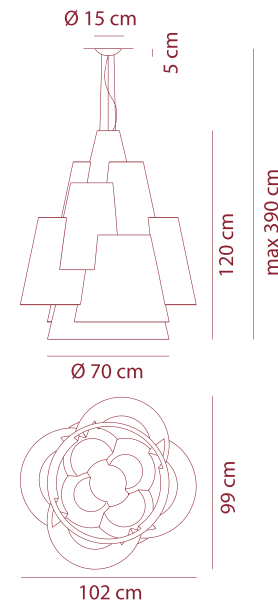

SP MEL 120

Source:
E27 3 x Max 16W LED or
3 x Max 23W fluo or
3 x Max 70W halo

CE **IP20 +LED**

Diffuser not included (optional)

COLOURS

light patterns:

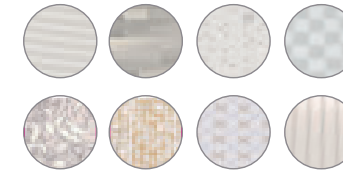

Diffusers not included (optional)

FINISH



dark patterns:

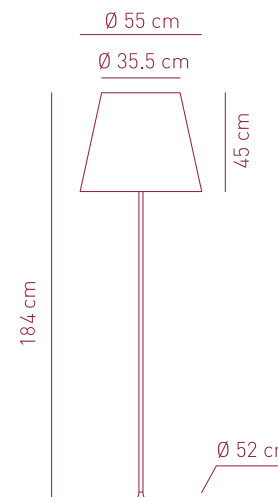

PT MELT 55

Source:
E27 3 x Max 16W LED or
3 x Max 15W fluo or
3 x Max 70W halo

(Dimmable lamps required)

CE **IP20 - dimmable +LED**

COLOURS



FINISH



Meling Pot

design Sandro Santantonio

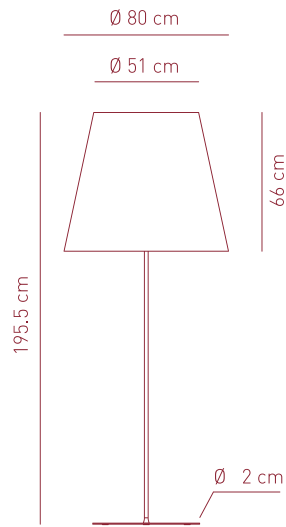

Collection consisting of wall lamps, suspended lamps and floor lamps. The lampshades coming in various decorative patterns. Opalescent diffusers available on request. Screw fitting light source.
 Collezione composta da lampade da parete, a sospensione e da terra. I paralumi sono proposti con diversi pattern decorativi. Diffusori opalescenti disponibili su richiesta. Sorgente luminosa con attacco a vite.

PT MELT 80

Source:
E27 3 x Max 16W LED or
 3 x Max 15W fluo or
 3 x Max 70W halo

CE IP20 dimmable +LED

FINISH



COLOURS



light patterns:



BA
 light patterns outside/
 silver inside

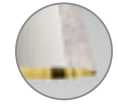

BO
 light patterns outside/
 gold inside



dark patterns:

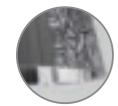

NA
 dark patterns outside/
 silver inside

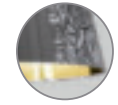

NE
 dark patterns outside/
 gold inside

Momus Mini

design Manuel Vivian

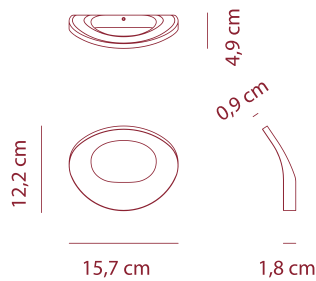

Wall lamp in white aluminium. Built-in LED light source.
 Lampada da parete in alluminio bianco. Sorgente luminosa a LED integrato.

MOMUS MINI WALL

Source:
LED 3W - diffused beam - 3000K
 CRI 85 - 160 lm - 53 lm/W

CE IP20 ADA LED

COLOUR



driver included

Mountain View

design Dima Loginoff

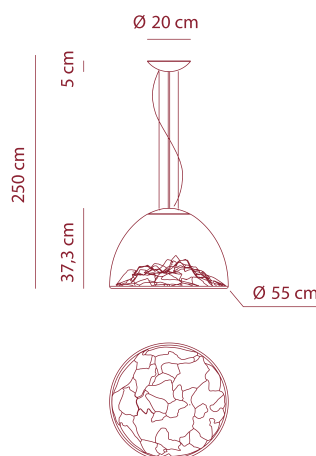

Suspended lamp made of transparent blown glass.
 Lampada a sospensione realizzata in vetro soffiato trasparente.

SP MOUNTA

Source:
LED 16W - 3000K
 CRI 80 - ~1345 lm - 84 lm/W

CE IP20 dimmable phase cut LED

COLOURS

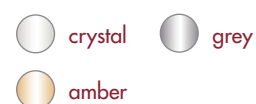

FINISH

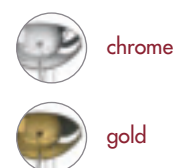

Muse

design Sandro Santantonio

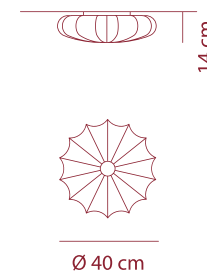

Collection consisting of ceiling, wall, suspended and table lamps with metal frame and removable, washable elastic fabric covering.
 Collezione composta da lampade da soffitto, da parete, a sospensione e da tavolo con struttura metallica e rivestimento in tessuto elasticizzato, sfoderabile e lavabile.

PL MUSE 40

application: both as ceiling or wall lamp

Source:
E27 1 x Max 6,5W LED or
 1 x Max 42W halo

CE IP20 +LED

COLOURS

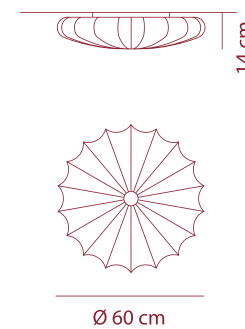

PL MUSE 60

application: both as ceiling or wall lamp

Source:
E27 2 x Max 6,5W LED or
 2 x Max 42W halo

CE IP20 +LED

COLOURS

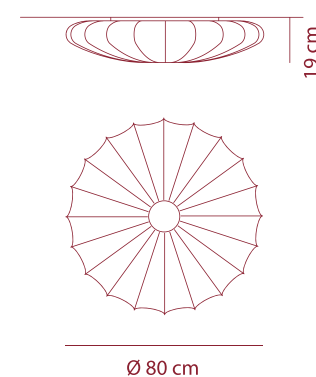

PL MUSE 80

application: both as ceiling or wall lamp

Source:
E27 3 x Max 16W LED or
 3 x Max 70W halo

CE IP20 +LED

Diffuser kit only for E27 when mounting LED or fluo bulb (optional)

COLOURS



Muse

design Sandro Santantonio

Collection consisting of ceiling, wall, suspended and table lamps with metal frame and removable, washable elastic fabric covering.
Collezione composta da lampade da soffitto, da parete, a sospensione e da tavolo con struttura metallica e rivestimento in tessuto elasticizzato, sfoderabile e lavabile.

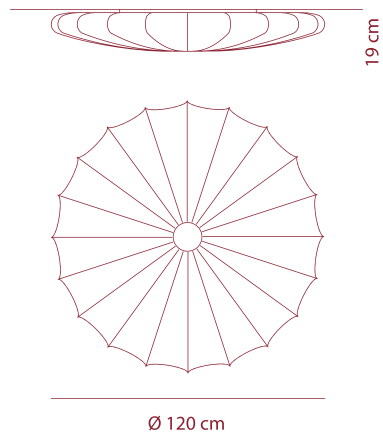

PL MUS 120
application: both as ceiling or wall lamp

Source:
E27 3 x Max 16W LED or
 3 x Max 70W halo

CE IP20 +LED

Glass diffuser kit only for E27
 when mounting LED
 or fluo bulb (optional)

COLOURS

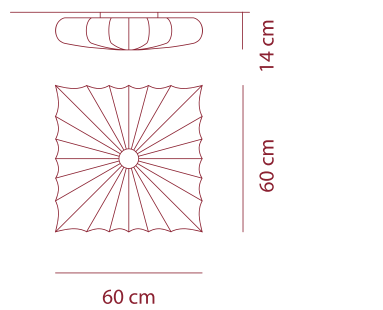

PL MUS 60 Q
application: both as ceiling or wall lamp

Source:
E27 2 x Max 6,5W LED or
 2 x Max 42W halo

CE IP20 +LED

COLOUR

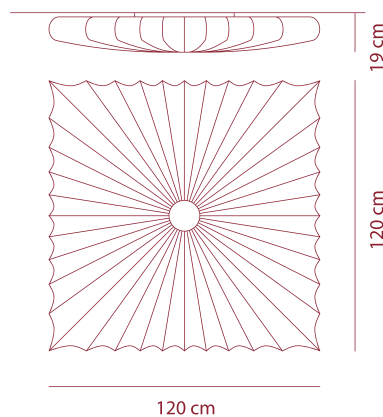

PL MUS 120 Q
application: both as ceiling or wall lamp

Source:
E27 3 x Max 16W LED or
 3 x Max 70W halo

CE IP20 +LED

Glass diffuser kit only for E27
 when mounting LED
 or fluo bulb (optional)

COLOUR

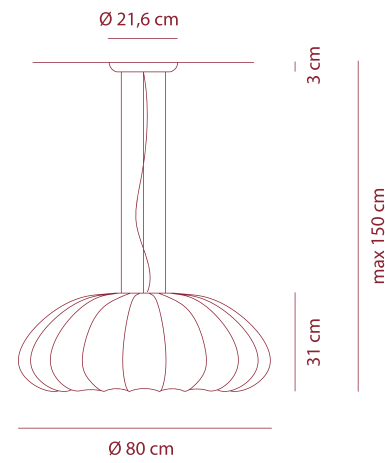

SP MUSE

Source:
E27 1 x Max 20W LED or
 1 x Max 116W halo

CE IP20 +LED

COLOURS



FINISH

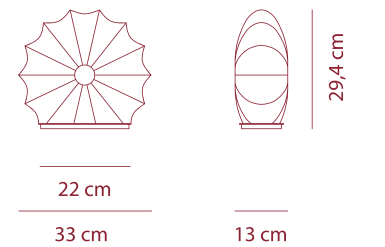

LT MUSE P

Source:
E14 1 x Max 6,5W LED or
 1 x Max 42W halo

CE IP20 +LED

COLOURS



FINISH

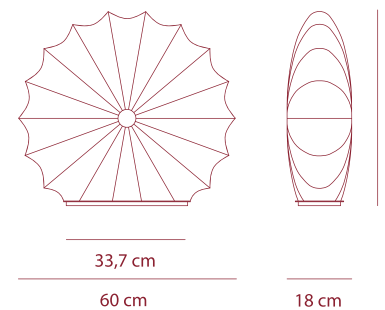

LT MUSE G

Source:
E27 1 x Max 20W LED or
 1 x Max 105W halo
 (dimming lamps required)

CE IP20 - +LED
 dimmable

COLOURS



FINISH



Nafir

design Karim Rashid

Collection consisting of recessed downlights, ceiling lamps and suspended lamps in injection moulded ABS.
Collezione composta da faretti ad incasso, lampade da soffitto e lampade a sospensione in ABS ad iniezione.

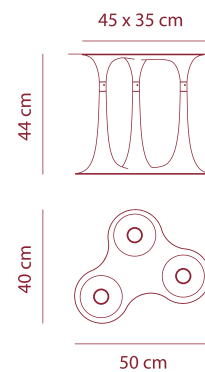

PL NAFIR 3

Source:
GU10 LED 3 x Max 7,5W
only LED bulb 220-240VAC

CE IP20 LED

COLOURS



Nafir

design Karim Rashid

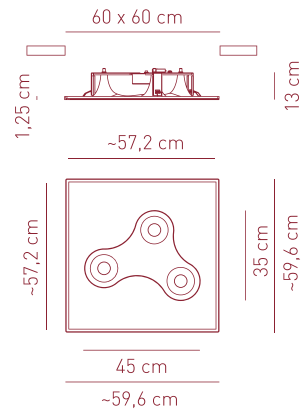

Collection consisting of recessed downlights, ceiling lamps and suspended lamps in injection moulded ABS.

Collezione composta da faretti ad incasso, lampade da soffitto e lampade a sospensione in ABS ad iniezione.

PL NAFI 3

Source:
GU5.3 LED 3 x Max 5W
- **only** LED bulbs 220-240VAc



COLOURS

- white
- white/chrome
- white/gold

transformer included

hole 59,6 x 59,6 cm
min depth: 15 cm (standard false ceiling) or
or 40 cm (false ceiling tiles)

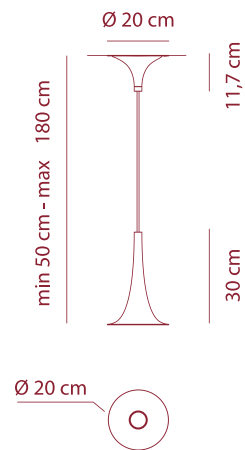

SP NAFIR 1

Source:
GU10 LED 1 x Max 7,5W
- **only** LED bulbs 220-240VAc



COLOURS

- white
- white/chrome
- white/gold
- white/bronze
- white/pink gold

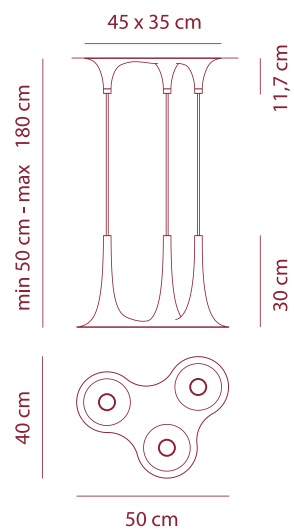

SP NAFIR 3

Source:
GU10 LED 3 x Max 7,5W
- **only** LED bulbs 220-240VAc



COLOURS

- white
- white/chrome
- white/gold
- white/bronze
- white/pink gold

Necky

design Diadora Design

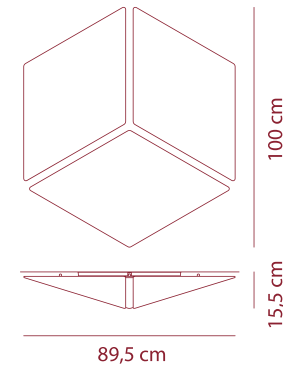

Ceiling or wall lamp with metal frame and white removable, washable elastic fabric covering. Screw fitting light source.

Lampada da parete o da soffitto con struttura metallica e rivestimento in tessuto bianco elasticizzato, sfoderabile e lavabile. Sorgente luminosa con attacco a vite.

PL NEC 100
application: both as ceiling or wall lamp

COLOURS

- white

Source:
E27 3 x Max 6,5W LED or
3 x Max 42W halo



Nelly

design Manuel Vivian

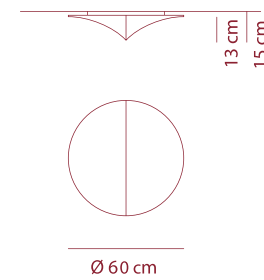

Collection consisting of ceiling or wall lamps with metal frame and removable, washable elastic fabric covering. Screw fitting light source.

Collezione di lampade da parete o da soffitto con struttura metallica e rivestimento in tessuto elasticizzato, sfoderabile e lavabile. Sorgente luminosa con attacco a vite.

PL NELL 60
application: both as ceiling or wall lamp

COLOURS

- white
- ivory pattern
- white pattern

Source:
E27 2 x Max 16W LED or
2 x Max 70W halo

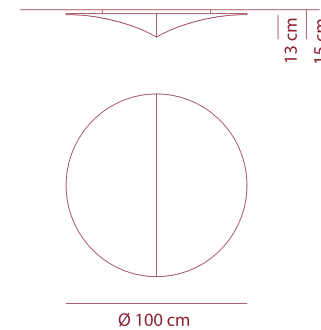

PL NEL 100
application: both as ceiling or wall lamp

COLOURS

- white
- ivory pattern
- white pattern

Source:
E27 3 x Max 16W LED or
3 x Max 70W halo

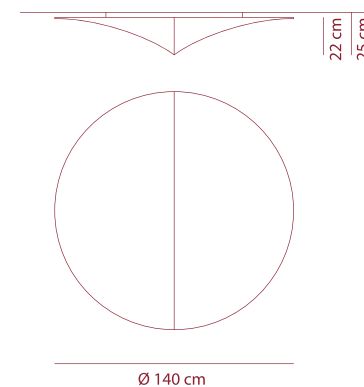

PL NEL 140
application: both as ceiling or wall lamp

COLOURS

- white
- ivory pattern
- white pattern

Source:
E27 4 x Max 16W LED or
4 x Max 70W halo



Nelly Straight

design Manuel Vivian

Collection consisting of ceiling or wall lamps with metal frame and removable, washable elastic fabric covering.
Collezione di lampade da parete o da soffitto con struttura metallica e rivestimento in tessuto elasticizzato. Disponibile in vari colori e dimensioni.

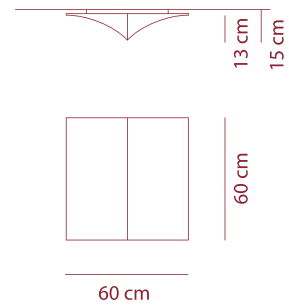

PL NEL S 60
application: both as ceiling or wall lamp

Source:
E27 2 x Max 16W LED or
 2 x Max 70W halo

CE IP20 +LED

COLOURS

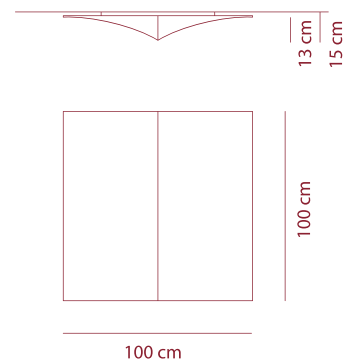

PL NE S 100
application: both as ceiling or wall lamp

Source:
E27 3 x Max 16W LED or
 3 x Max 70W halo

CE IP20 +LED

COLOURS

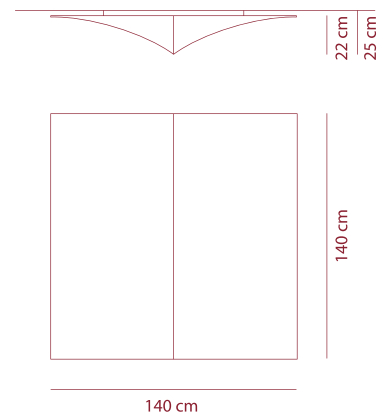

PL NE S 140
application: both as ceiling or wall lamp

Source:
E27 4 x Max 16W LED or
 4 x Max 70W halo

CE IP20 +LED

COLOURS



Orchid

design Rainer Mutsch

Collection consisting of aluminium wall lamps, ceiling lamps, suspended lamps and floor lamps. Built-in dimmable LED light source.
Collezione composta da lampade da parete, lampade da soffitto, lampade a sospensione e lampade da terra in alluminio. La sorgente luminosa è a LED integrato dimmerabile.

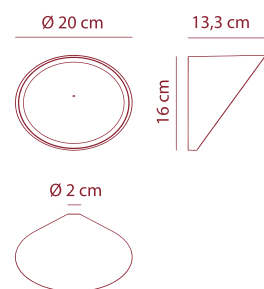

AP ORCHID
application: both as ceiling or wall lamp

Source:
LED 15W - diffused beam - 3000K
 CRI 90 - ~882 lm - 59 lm/W

CE IP20 +LED

COLOURS

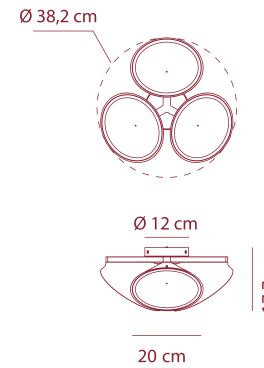

PL ORCHID

Source:
LED 3 x 15W - diffused beam - 3000K
 CRI 90 - 3 x ~882 lm - 59 lm/W

CE IP20 +LED

COLOURS

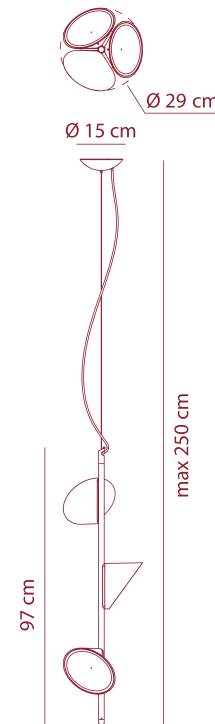

SP ORCHI 3

Source:
LED 3 x 15W - diffused beam - 3000K
 CRI 90 - 3 x ~882 lm - 59 lm/W

CE IP20 +LED

COLOURS



FINISH

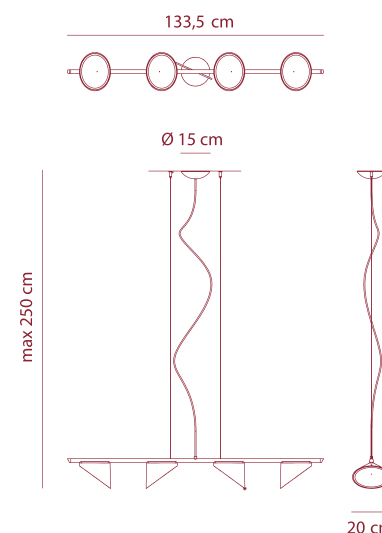

SP ORCHI 4

Source:
LED 4 x 15W - diffused beam - 3000K
 CRI 90 - 4 x ~882 lm - 59 lm/W

CE IP20 +LED

COLOURS



FINISH



Orchid

design Rainer Mutsch

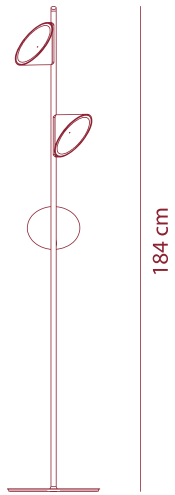

Ø 35 cm

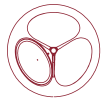

Collection consisting of aluminium wall lamps, ceiling lamps, suspended lamps and floor lamps. Built-in dimmable LED light source.

Collezione composta da lampade da parete, lampade da soffitto, lampade a sospensione e lampade da terra in alluminio. La sorgente luminosa è a LED integrato dimmerabile.

PT ORCHID

Source:

LED 3 x 15W - warm light 3000K
CRI 90 - 3 x ~882 lm - 59 lm/W

CE IP20 - dimmable 220-240VAc **LED**

COLOURS

white sand

FINISH

white metal
sand metal

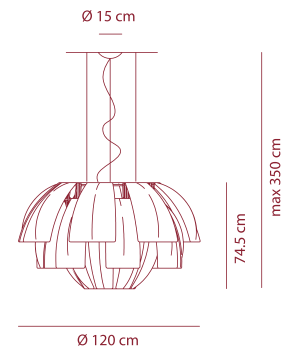

SP PLU 120

Source:

E27 6 x Max 16W LED or
6 x Max 20W fluo or
6 x 70W halo

CE IP20 **+LED**

COLOUR

white

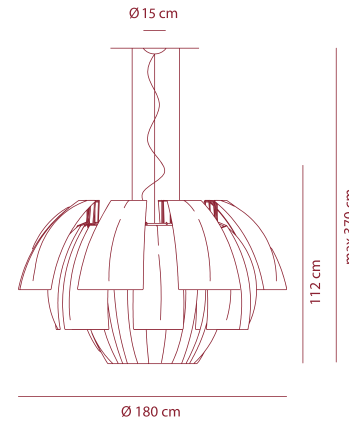

SP PLU 180

Source:

E27 6 x Max 16W LED or
6 x Max 20W fluo or
6 x 70W halo

CE IP20 **+LED**

COLOUR

white

Plumage

design Vanessa Vivian

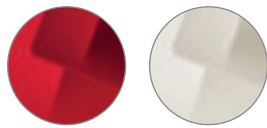

Collection consisting of suspended lamps and floor lamps with white metal frame and fabric diffusers covered with flame-retardant TREVIRA® CS. Screw fitting light source.

Collezione composta da lampade da sospensione e lampade da terra con struttura in metallo verniciato bianco e diffusori in tessuto TREVIRA® CS ignifugato. Sorgente luminosa con attacco a vite.

COMPOSITION/COMPOSIZIONE

Fireproof TREVIRA® CS fabric - 100% polyester

Tessuto TREVIRA® CS ignifugo - 100% poliestere

Glow Wire Test (EN 60598-1): 960°C

FIREPROOF CLASS/CLASSE IGNIFUGAZIONE

I = C1, F = M1 (NF P 92501-7), D = B1 (DIN 4102), EN 1021/1-2,

GB = Crib 5, IMO A 652, GB = BS 7176 Medium Hazard

WEIGHT/PESO

single fabric: 340 ± 5% gr/m²

AVAILABLE UPON REQUEST

orange fuchsia light grey
brown red light green
multicolor

COLOUR

white

SP PLU 080

Source:

E27 3 x Max 16 LED or
3 x Max 20W fluo or
3 x Max 70W halo

CE IP20 **+LED**

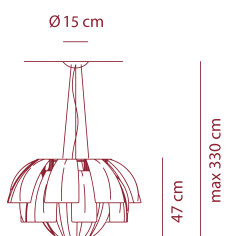

Ø 80 cm

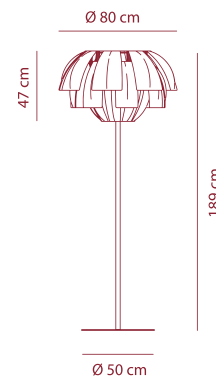

PT PLU 080

Source:

E27 3 x Max 16W LED or
3 x Max 20W fluo dimmable or
3 x Max 70W halo

CE IP20 - dimmable **+LED**

COLOUR

white

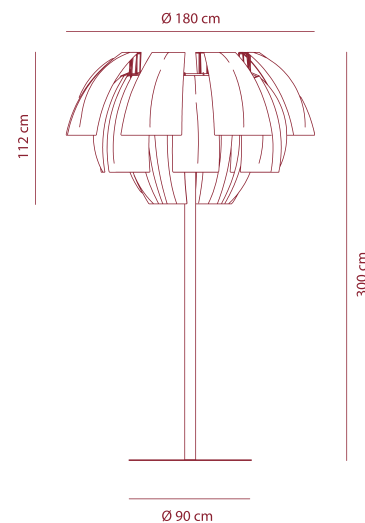

PT PLU 180

Source:

E27 3 x Max 16W LED or
6 x Max 20W fluo or
6 x 70W halo

CE IP20 - dimmable **+LED**

COLOUR

white

Polia LED

design Manuel Vivian

Collection consisting of metal wall lamps available in several colours and sizes.
Built-in dimmable LED light source.

Collezione di lampade da parete in metallo, disponibile in vari colori e dimensioni.
Sorgente luminosa a LED integrato dimmerabile.

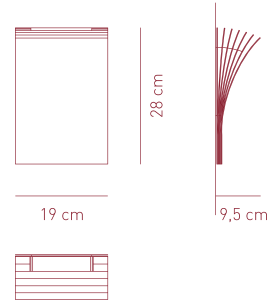

AP POLIA P

Source:
LED 16W - diffused beam - 3000K
CRI 90 - ~957 lm - 60 lm/W



220-240VAC **LED**

COLOURS

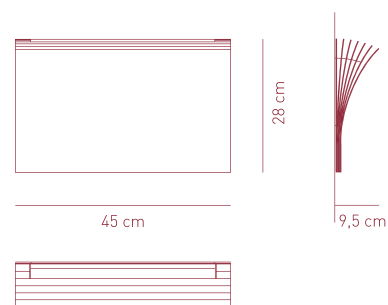

AP POLIA G

Source:
LED 24W - diffused beam - 3000K
CRI 90 - ~1436 lm - 60 lm/W



220-240VAC **LED**

COLOURS



Rythmos

design Serge & Robert Cornelissen

Collection consisting of wall lamps and suspended lamps in white metal.
Built-in LED light source mono-emitting or bi-emitting.

Collezione composta da lampade da parete e lampade a sospensione in metallo bianco. Sorgente luminosa a LED integrato monoemissione o biemissione.

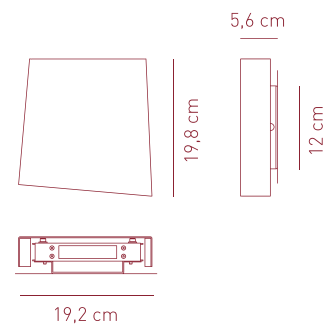

RYTHMOS WALL

Source:
LED 9W (monoemitting)
- diffused beam - 3000K

LED 18W (biemitting)
- diffused beam - 3000K
CRI 85 - ~397 lm - 44 lm/W (monoemitting)
CRI 85 - ~802 lm - 45 lm/W (biemitting)



COLOUR

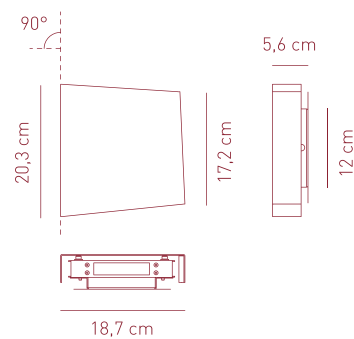

RYTHMOS HEAD

Source:
LED 9W (monoemitting)
- diffused beam - 3000K

LED 18W (biemitting)
- diffused beam - 3000K
CRI 85 - ~397 lm - 44 lm/W (monoemitting)
CRI 85 - ~802 lm - 45 lm/W (biemitting)



COLOUR

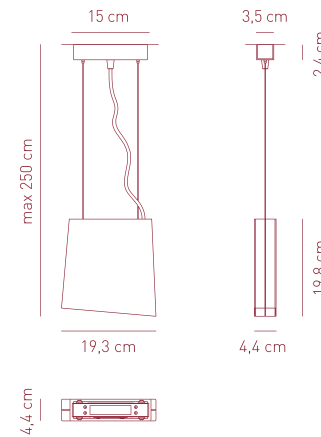

RYTHMOS SUSPENSION

Source:
LED 9W (monoemitting)
- diffused beam - 3000K

LED 15W (biemitting)
- diffused beam - 3000K
CRI 85 - ~397 lm - 44 lm/W (monoemitting)
CRI 85 - ~628 lm - 42 lm/W (biemitting)



COLOURS



Shatter LED

design Serge & Robert Cornelissen

Collection consisting of wall lamp, ceiling lamps and suspended lamps in white aluminium. Built-in dimmable LED light source.

Collezione composta da lampada da parete, lampade da soffitto e lampada a sospensione in alluminio bianco. Sorgente luminosa a LED integrato dimmerabile.

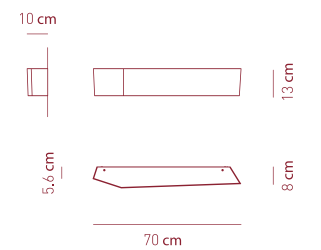

AP SHATTE LED

Source:
LED 32,8W - diffused beam - 3000K
CRI 80 - ~2976 lm - 90 lm/W



COLOUR



FINISH

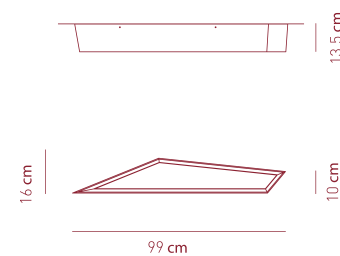

PL SHATT P LED

Source:
LED 32,8W - diffused beam - 3000K
CRI 80 - ~2080 lm - 63 lm/W



COLOUR



FINISH

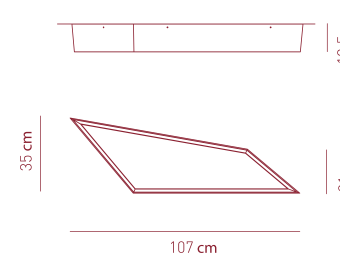

PL SHATT M LED

Source:
LED 65,6W - diffused beam - 3000K
CRI 80 - ~4960 lm - 76 lm/W



COLOURS



FINISH



Shatter LED

design Serge & Robert Cornelissen

Collection consisting of wall lamp, ceiling lamps and suspended lamps in white aluminium. Built-in dimmable LED light source.

Collezione composta da lampada da parete, lampade da soffitto e lampada a sospensione in alluminio bianco. Sorgente luminosa a LED integrato dimmerabile.

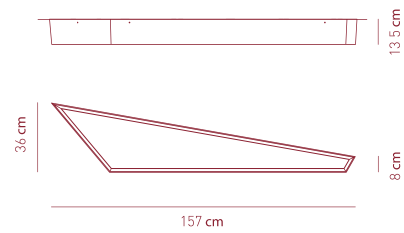

PL SHATT G LED

Source:
LED 98,4W - diffused beam - 3000K
CRI 80 - ~7440 lm - 76 lm/W



COLOUR

wrinkled white aluminium

FINISH

white

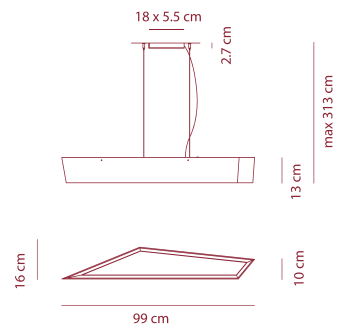

SP SHATT P LED downward light only

Source:
LED 32,8W - diffused beam - 3000K
CRI 80 - ~2080 lm - 63 lm/W



COLOUR

wrinkled white aluminium

FINISH

white canopy

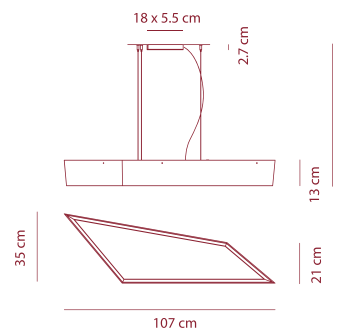

SP SHATT M LED downward light only

Source:
LED 65,6W - diffused beam - 3000K
CRI 80 - ~4960 lm - 76 lm/W



COLOUR

wrinkled white aluminium

FINISH

white canopy

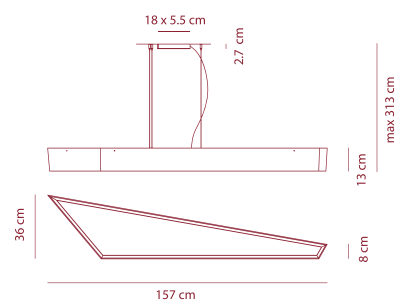

SP SHATT G LED downward light only

Source:
LED 98,4W - diffused beam - 3000K
CRI 80 - ~7440 lm - 76 lm/W



COLOUR

wrinkled white aluminium

FINISH

white canopy

Skin

design Manuel Vivian

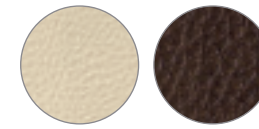

Collection consisting of ceiling lamps and suspended lamps. The lampshade is covered with flame-retardant eco-leather. Screw fitting or built-in dimmable LED light source.

Collezione composta da lampade da soffitto e lampade a sospensione con paralume in ecopelle ignifuga. Sorgente luminosa con attacco a vite o a LED integrato dimmerabile.

COMPOSITION/COMPOSIZIONE

Flame retardant Eco-leather - 87% PVC + 13% polyester
Extra smooth flame retardant pongé fabric - 100% polyester

Eco pelle ignifuga - 87% PVC + 13% poliestere
Tessuto ignifugato pongé superliscio - 100% poliestere

Glow Wire Test (EN 60598-1): 960°C

WEIGHT/PESO

550 ± 5% gr/m²

AVAILABLE UPON REQUEST



RADIAL DIFFUSER UPON REQUEST

warm white

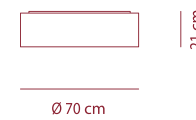

PL SKI 070

Source:
E27 2 x Max 16W LED or
2 x Max 20W fluo



COLOUR

white

RADIAL DIFFUSER

white



PL SKI 100

Source:
E27 3 x Max 16W LED or
3 x Max 23W fluo



COLOUR

white

RADIAL DIFFUSER

white



PL SKI 160

Source:
E27 5 x Max 16W LED or
5 x Max 23W fluo



COLOUR

white

RADIAL DIFFUSER

white

Skin

design Manuel Vivian

Collection consisting of ceiling lamps and suspended lamps. The lampshade is covered with flame-retardant eco-leather. Screw fitting or built-in dimmable LED light source.

Collezione composta da lampade da soffitto e lampade a sospensione con paralume in ecopelle ignifuga. Sorgente luminosa con attacco a vite o a LED integrato dimmerabile.

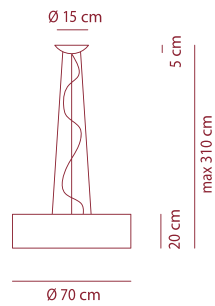

SP SKI 070 with upward & downward lighting

Source:
E27 4 x Max 16W LED or
4 x Max 20W fluo

CE IP20 +LED

COLOUR

○ white

RADIAL DIFFUSER

○ white

FINISH

○ white canopy

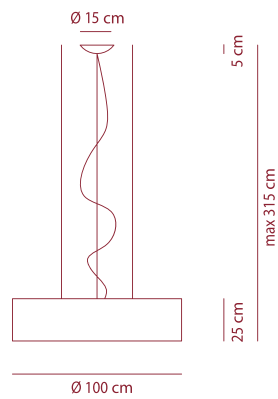

SP SKI 100 with upward & downward lighting

Source:
E27 6 x Max 16W LED or
6 x Max 20W fluo

CE IP20 +LED

SP SKI 100 LED

Source:
LED 95W - diffused beam - 3000K
CRI 90 - ~5896 lm - 62 lm/W

CE IP20 - dimmable DALI +LED

COLOUR

○ white

RADIAL DIFFUSER

○ white

FINISH

○ white canopy

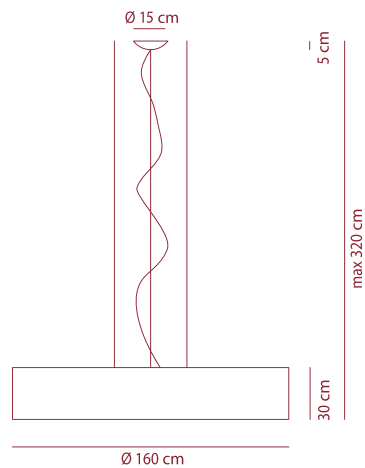

SP SKI 160 with upward & downward lighting

Source:
E27 6 x Max 16W LED or
6 x Max 20W fluo

CE IP20 +LED

SP SKI 100 LED

Source:
LED 95W - diffused beam - 3000K
CRI 90 - ~5896 lm - 62 lm/W

CE IP20 - dimmable DALI +LED

COLOUR

○ white

RADIAL DIFFUSER

○ white

FINISH

○ white canopy

Skirt

design Manuel Vivian

Collection consisting of ceiling, suspended and table lamps in flame-retardant TREVIRA®CS fabric. The fabric can also come in a double-layer version with an exterior black net fabric. A decorative inner lampshade (also printable with customized graphic) available only for some of the suspended and ceiling lamps.

Collezione di lampade da soffitto, a sospensione e da tavolo con paralume in tessuto ignifugato TREVIRA® CS. Disponibile anche con tessuto esterno retato nero. Un paralume decorativo interno (stampabile anche con grafica personalizzata) è disponibile per alcune lampade a sospensione e lampade da soffitto.

LAMPSHADES COLOURS/COLORI PARALUMI

The fabrics are available individually or combined with black net. For the version with overlapping black net add "NE" before the color code.

I tessuti sono disponibili singolarmente o accoppiati a rete nera. Per la versione con rete nera aggiungere "NE" anteposto al codice colore.

COMPOSITION/COMPOSIZIONE

Fireproof TREVIRA® CS fabric - 100% polyester
Tessuto TREVIRA® CS ignifugo - 100% poliestere

Glow Wire Test (EN 60598-1): 960 °C

FIREPROOF CLASS/CLASSE IGNIFUGAZIONE

I = C1, F = M1 (NF P 92501-7), D = B1 (DIN 4102), EN 1021/1-2,
GB = Crib 5, IMO A 652, GB = BS 7176 Medium Hazard

WEIGHT/PESO

black net finish fabric/Finitura a rete nera: 214 ± 5% gr/m2
single fabric/tessuto singolo: 340 ± 5% gr/m2

AVAILABLE UPON REQUEST

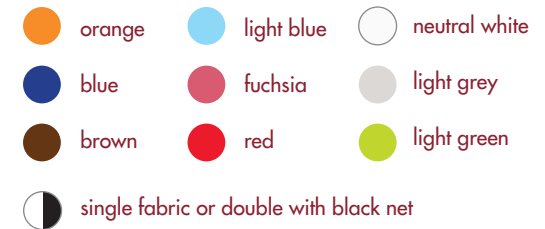

AP SKR 028

COLOUR

○ white

Source:
FLUO 2610 1 x 36W

CE IP20

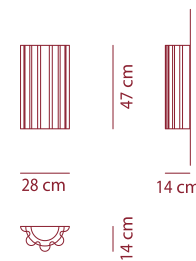

PL SKR 070

COLOUR

○ white

Source:
E27 1 x Max 16W LED or
1 x Max 23W fluo or
1 x Max 70W halo

CE IP20 +LED

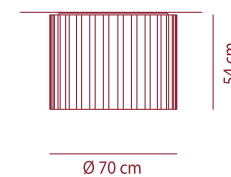

PL SKR 100

COLOUR

○ white

Source:
E27 3 x Max 16W LED or
3 x Max 23W fluo or
3 x Max 70W halo

CE IP20 +LED

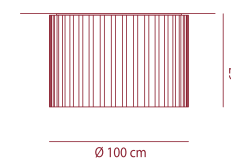

PL SKR 150

COLOUR

○ white

Source:
E27 4 x Max 16W LED or
4 x Max 23W fluo or
4 x Max 70W halo

CE IP20 +LED

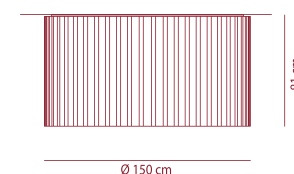

Skirt

design Manuel Vivian

Collection consisting of ceiling, suspended and table lamps in flame-retardant TREVIRA®CS fabric. The fabric can also come in a double-layer version with an exterior black net fabric. A decorative inner lampshade (also printable with customized graphic) available only for some of the suspended and ceiling lamps.

Collezione di lampade da soffitto, a sospensione e da tavolo con paralume in tessuto ignifugato TREVIRA® CS. Disponibile anche con tessuto esterno retato nero. Un paralume decorativo interno (stampabile anche con grafica personalizzata) è disponibile per alcune lampade a sospensione e lampade da soffitto.

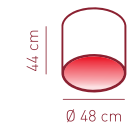
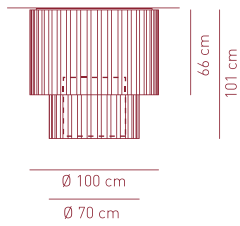

PL SK 100 2

COLOUR



Source:

- E27** 3 x Max 16W LED or
3 x Max 23W fluo or
3 x Max 70W halo

CE IP20 +LED

DECORATIVE LAMPSHADE OPTIONAL

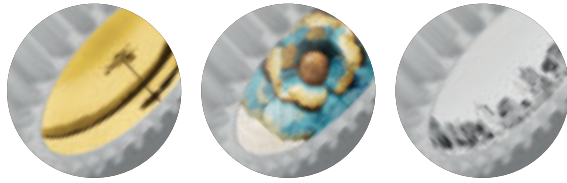

Optional inner decorative lampshade.
Available only for PL/SP SK 100 2 & PL/SP SK 150 2

Inner decorative printed lampshade with customized graphic:
contact Axo Light customer service for further info

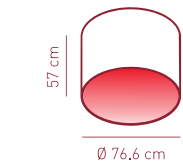
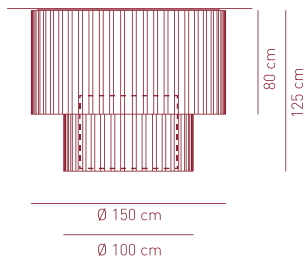

PL SK 150 2

COLOUR



Source:

- E27** 4 x Max 16W LED or
4 x Max 23W fluo or
4 x Max 70W halo

CE IP20 +LED

DECORATIVE LAMPSHADE OPTIONAL

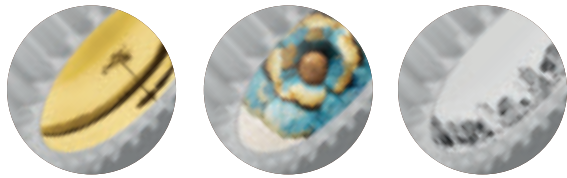

Optional inner decorative lampshade.
Available only for PL/SP SK 100 2 & PL/SP SK 150 2

Inner decorative printed lampshade with customized graphic:
contact Axo Light customer service for further info

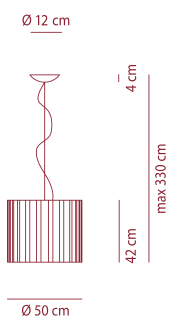

SP SKR 050

COLOUR



Source:

- E27** 1 x Max 20W LED or
1 x Max 33W fluo or
1 x Max 70W halo

CE IP20 +LED

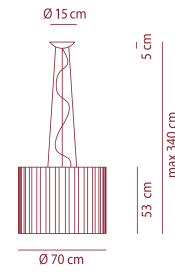

SP SKR 070

COLOUR



Source:

- E27** 1 x Max 20W LED or
1 x Max 33W fluo or
1 x Max 70W halo

CE IP20 +LED

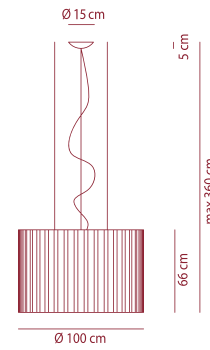

SP SKR 100 with upward & downward lighting

COLOUR



Source:

- E27** 4 x Max 20W LED or
4 x Max 33W fluo or
4 x Max 70W halo

CE IP20 +LED

SP SKR 100 LED

Source:

- LED** 95W - diffused beam - 3000K
CRI 90 - ~6209 lm - 65 lm/W

CE IP20 dimmable DALI LED

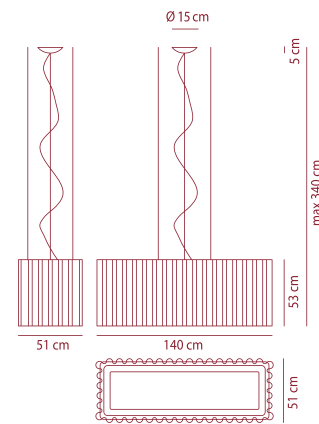

SP SKR 140

COLOUR



Source:

- E27** 4 x Max 16W LED or
4 x Max 23W fluo or
4 x Max 57W halo

CE IP20 +LED

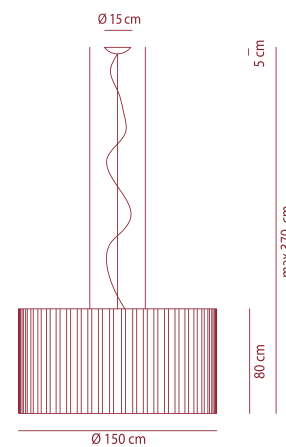

SP SKR 150 with upward & downward lighting

COLOUR



Source:

- E27** 4 x Max 16W + 1 x Max 12W LED or
5 x Max 23W fluo or
4 x Max 70W + 1 x 57W halo

CE IP20 +LED

SP SKR 150 LED

Source:

- LED** 95W diffused beam - 3000K
CRI 90 - ~6209 lm - 65 lm/W

CE IP20 dimmable DALI LED

Skirt

design Manuel Vivian

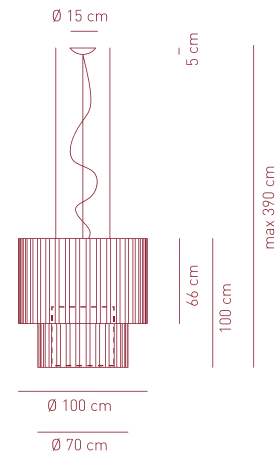

Collection consisting of ceiling, suspended and table lamps in flame-retardant TREVIRA®CS fabric. A decorative inner lampshade (also printable with customized graphic) available only for some of the suspended and ceiling lamps.

Collezione di lampade da soffitto, a sospensione e da tavolo con paralume in tessuto ignifugato TREVIRA® CS. Un paralume decorativo interno (stampabile anche con grafica personalizzata) è disponibile per alcune lampade a sospensione e lampade da soffitto.

SP SK 100 2 with upward & downward lighting

COLOUR



Source:

E27 4 x Max 20W LED or
4 x Max 33W fluo or
4 x Max 70W halo

CE IP20 +LED

SP SK 100 2 LED

Source:

LED 95W - diffused beam - 3000K
CRI 90 - ~5896 lm - 62 lm/W

CE IP20 dimmable DALI LED

DECORATIVE LAMPSHADE OPTIONAL

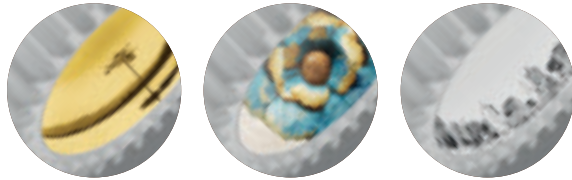

Optional inner decorative lampshade.

Available only for PL/SP SK 100 2 & PL/SP SK 150 2

Inner decorative printed lampshade with customized graphic:
contact Axo Light customer service for further info

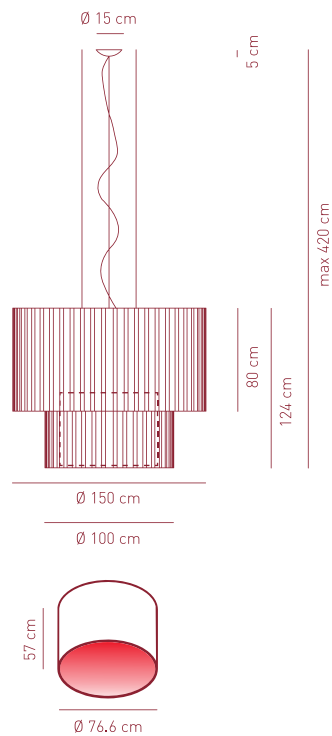

SP SK 150 2 with upward & downward lighting

COLOUR



Source:

E27 4 x Max 16W + 1 x Max 12W LED or
5 x Max 23W fluo or
4 x Max 70W + 1 x Max 57W halo

CE IP20 +LED

SP SK 150 2 LED

Source:

LED 95W - diffused beam - 3000K
CRI 90 - ~5896 lm - 62 lm/W

CE IP20 dimmable DALI LED

DECORATIVE LAMPSHADE OPTIONAL



Optional inner decorative lampshade.

Available only for PL/SP SK 100 2 & PL/SP SK 150 2

Inner decorative printed lampshade with customized graphic:
contact Axo Light customer service for further info

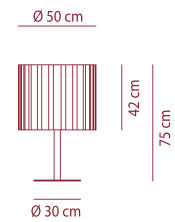

LT SKR 050

COLOUR



Source:

E27 3 x Max 16W LED or
3 x Max 23W fluo or
3 x Max 46W halo

CE IP20 +LED

Sol

design Manuel Vivian

Ceiling lamp in white aluminium. Built-in LED light source.

Lampada da soffitto in alluminio bianco. Sorgente luminosa a LED.

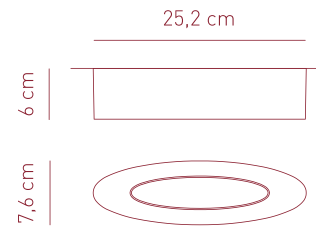

SOL CEILING

COLOUR



Source:

LED 9W - diffused beam - 3000K
CRI 85 - 524 lm - 52 lm/W

CE IP20 LED

Spillray

design Manuel Vivian

Collection consisting of wall lamps, recessed ceiling lamps and suspended lamps. The diffusers are made of glass with chrome-plated metal frame. Available in several colours and sizes. Halo or LED light source.

Collezione di lampade da parete, lampade da soffitto ad incasso e lampade a sospensione in vetro con montatura in metallo cromato. Disponibile in vari colori e dimensioni. Sorgente luminosa alogena o a LED.

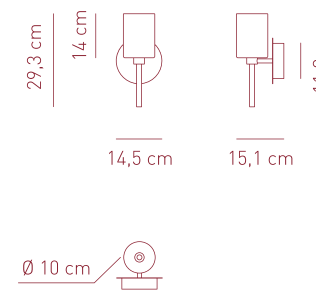

AP SPILLR

COLOURS



Source:

G4 1 x Max 20W 12VAc halo **included**

CE IP20 dimmable phase cut



FINISH

G4 1 x 1,5W 12Vdc **LED included**
- 12Vdc **only** LED bulb



CE IP20 LED

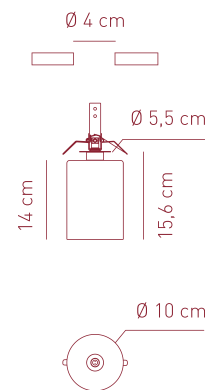

PL SPIL P I

COLOURS



Source:

G4 1 x Max 20W 12VAc halo **included**

CE IP20 with dedicated PSU



FINISH

transformer not included

PL SPIL P I LED



Source:

G4 1 x 1,5W 12Vdc **LED included**
- **only** LED bulb

CE IP20 LED

driver not included

hole Ø 4 cm
min depth 10 cm

Spillray

design Manuel Vivian

Collection consisting of wall lamps, recessed ceiling lamps and suspended lamps. The diffusers are made of glass with chrome-plated metal frame. Available in several colours and sizes. Halo or LED light source.
 Collezione di lampade da parete, lampade da soffitto ad incasso e lampade a sospensione in vetro con montatura in metallo cromato. Disponibile in vari colori e dimensioni. Sorgente luminosa alogena o a LED.

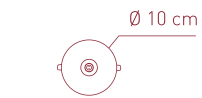
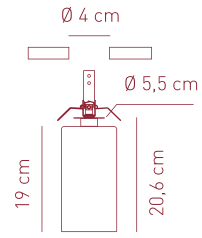

PL SPIL M I

Source:
G4 1 x Max 20W 12V_{ac} halo **included**
 CE IP20 with dedicated PSU
 transformer not included

- COLOURS**
- crystal
 - red
 - grey

- FINISH**
- chrome

PL SPIL M I LED

Source:
G4 1 x 1,5W 12V_{dc} **LED included**
 -only LED bulb
 CE IP20 LED

driver not included

hole Ø 5 cm
 min depth 10 cm

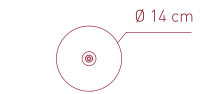
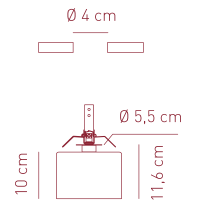

PL SPIL G I

Source:
G4 1 x Max 20W 12V_{ac} halo **included**
 CE IP20 with dedicated PSU
 transformer not included

- COLOURS**
- crystal
 - red
 - grey

- FINISH**
- chrome

PL SPIL G I LED

Source:
G4 1 x 1,5W 12 V_{dc} **LED included**
 -only LED bulb
 CE IP20 LED

driver not included

hole Ø 5 cm
 min depth 10 cm

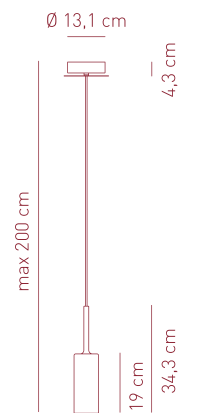

SP SPILL P

Source:
G4 1 x Max 20W 12V_{ac} halo **included**
 CE IP20 dimmable phase cut
 transformer not included

- COLOURS**
- crystal
 - red
 - grey
 - metallic bronze

- FINISH**
- chrome

G4 1 x 1,5W 12V_{dc} **LED included**
 -only LED bulb
 CE IP20 LED

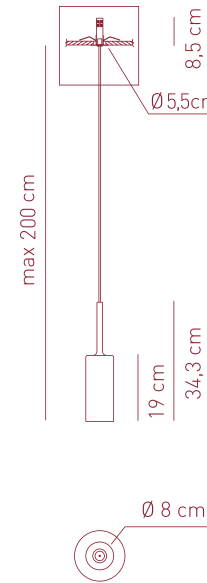

SP SPIL P I (recessed)

Source:
G4 1 x Max 20W 12V_{ac} halo **included**
 CE IP20 with dedicated PSU
 transformer not included

- COLOURS**
- crystal
 - red
 - grey
 - metallic bronze

- FINISH**
- chrome

G4 LED 1 x 1,5W 12V_{dc} **LED included**
 - only LED bulb
 CE IP20 LED

driver not included

hole Ø 4 cm
 min depth 10 cm

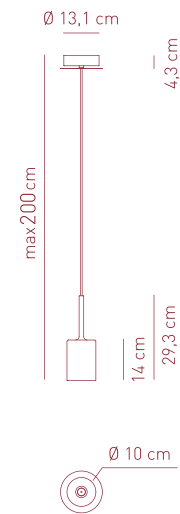

SP SPILL M

Source:
G4 1 x Max 20W 12V_{ac} halo **included**
 CE IP20 dimmable phase cut
 transformer not included

- COLOURS**
- crystal
 - red
 - grey
 - metallic bronze

- FINISH**
- chrome

G4 1 x 1,5W 12V_{dc} **LED included**
 - only LED bulb
 CE IP20 LED

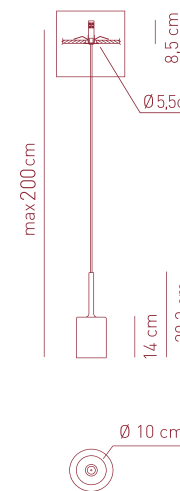

SP SPIL M I (recessed)

Source:
G4 1 x Max 20W 12V_{ac} halo **included**
 CE IP20 with dedicated PSU
 transformer not included

- COLOURS**
- crystal
 - red
 - grey
 - metallic bronze

- FINISH**
- chrome

G4 1 x 1,5W 12V_{dc} **LED included**
 - only LED bulb
 CE IP20 LED

driver not included

hole Ø 4 cm
 min depth 10 cm

Spillray

design Manuel Vivian

Collection consisting of wall lamps, recessed ceiling lamps and suspended lamps. The diffusers are made of glass with chrome-plated metal frame. Available in several colours and sizes. Halo or LED light source.
 Collezione di lampade da parete, lampade da soffitto ad incasso e lampade a sospensione in vetro con montatura in metallo cromato. Disponibile in vari colori e dimensioni. Sorgente luminosa alogena o a LED.

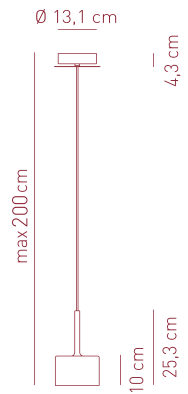

SP SPILL 6

Source:
G4 1 x Max 20W 12V_{ac} halo **included**



G4 1 x 1,5W 12V_{dc} **LED included**
-only LED bulb



COLOURS



FINISH

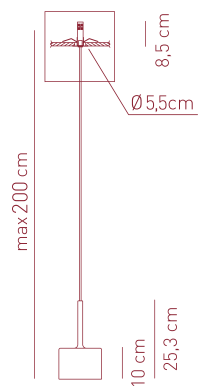
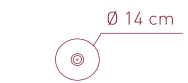
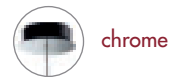

SP SPILL G I (recessed)

Source:
G4 1 x Max 20W 12V_{ac} halo **included**



transformer not included

G4 1 x 1,5W 12V_{dc} **LED included**
-only LED bulb



COLOURS



FINISH

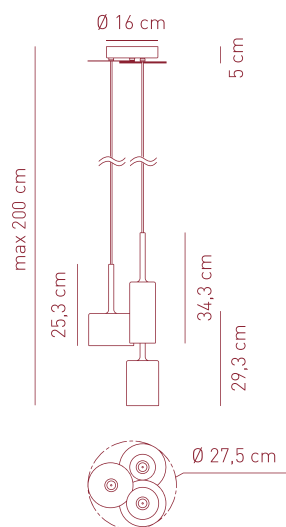
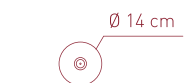

SP SPILL 3

Source:
G4 3 x Max 20W 12V_{ac} halo **included**



G4 3 x 1,5W 12V_{dc} **LED included**
-only LED bulb



COLOURS



FINISH

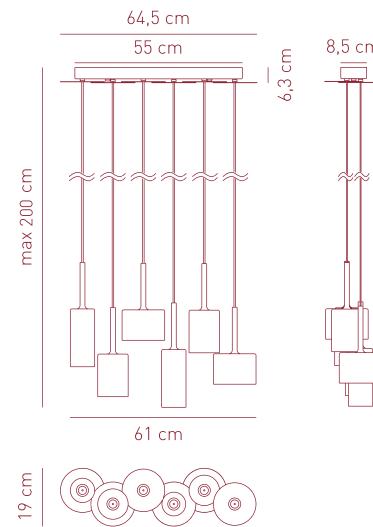

SP SPILL 6

Source:
G4 6 x Max 20W 12V_{ac} halo **included**



G4 6 x 1,5W 12V_{dc} **LED included**
-only LED bulb



COLOURS



FINISH

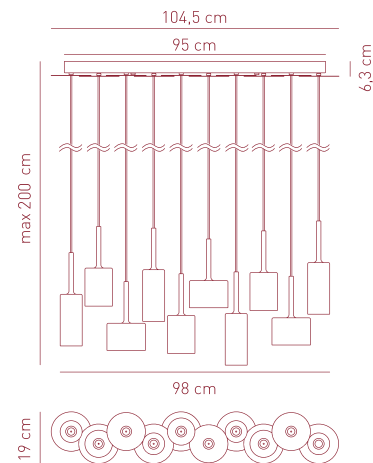

SP SPILL 10

Source:
G4 10 x Max 20W 12V_{ac} halo **included**



G4 10 x 1,5W 12V_{dc} **LED included**
-only LED bulb



COLOURS



FINISH

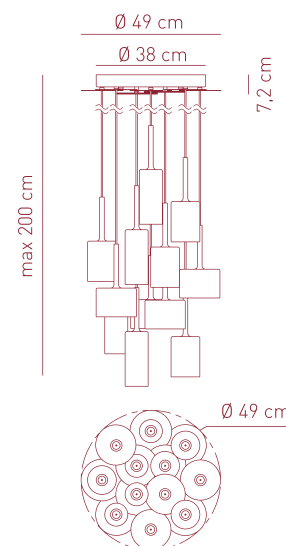

SP SPILL 12

Source:
G4 12 x Max 20W 12V_{ac} halo **included**



G4 12 x 1,5W 12V_{dc} **LED included**
-only LED bulb



COLOURS

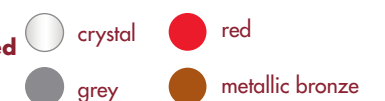

FINISH

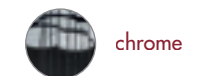

Spillray

design Manuel Vivian

Collection consisting of wall lamps, recessed ceiling lamps and suspended lamps. The diffusers are made of glass with chrome-plated metal frame. Available in several colours and sizes. Halo or LED light source.
 Collezione di lampade da parete, lampade da soffitto ad incasso e lampade a sospensione in vetro con montatura in metallo cromato. Disponibile in vari colori e dimensioni. Sorgente luminosa alogena o a LED.

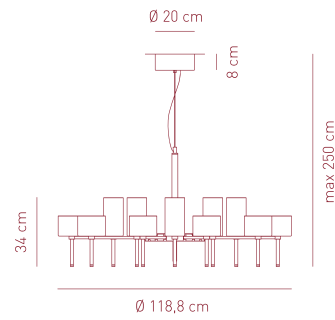

SP SPIL 20

Source:
G4 20 x Max 20W 12 Vac halo **included**
 CE IP20 dimmable phase cut

COLOURS

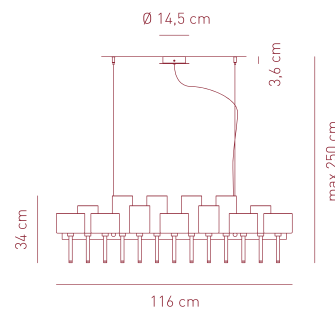
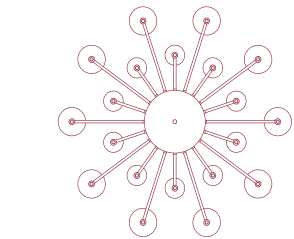

SP SPIL 26

Source:
G4 26 x Max 20W 12 Vac halo **included**
 CE IP20 dimmable phase cut

COLOURS

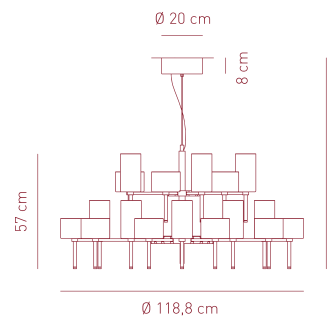
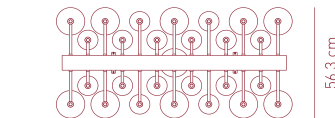

SP SPIL 30

Source:
G4 30 x Max 20W 12 Vac halo **included**
 CE IP20 dimmable phase cut

COLOURS

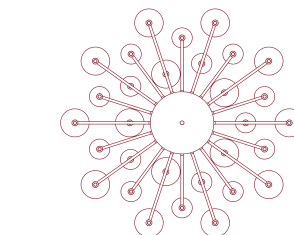

Spiry

design Giovanni Barbato

Suspended lamp in white bent aluminium. Screw fitting light source.
 Lampada a sospensione in alluminio curvato bianco. Sorgente luminosa con attacco a vite.

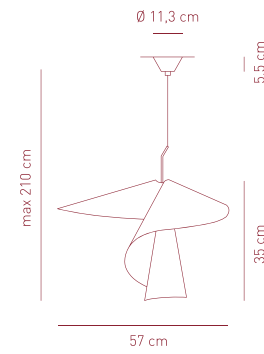

SP SPIRY

Source:
E27 1 x Max 20W LED or
 1 x Max 23W fluo or
 1 x Max 100W halo

CE IP20 +LED

COLOUR



FINISH



Stilla

design Manuel Vivian

Collection of aluminium suspended lamps, also in a recessed version. Available in several colours. Built-in LED light source.

Lampade a sospensione in alluminio in vari colori. Disponibile anche nella versione ad incasso. Sorgente luminosa a LED integrato.

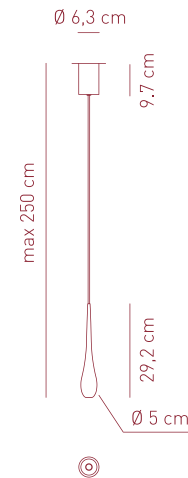

STILLA SUSPENSION monocanopy

Source:
LED 6,5W - 47° or 60° beam 3000K
 CRI 80 - 47° beam: ~688 lm - 106 lm/W
 CRI 80 - 60° beam: ~688 lm - 103 lm/W

CE IP20 LED

COLOURS

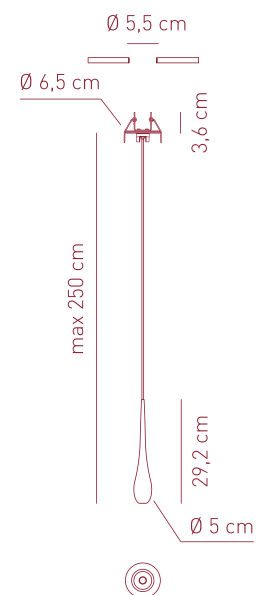

STILLA SUSPENSION recessed version

Source:
LED 6,6W - 350mA - 47° or 60° beam 3000K
 CRI 80 - 47° beam: ~688 lm - 106 lm/W
 CRI 80 - 60° beam: ~688 lm - 103 lm/W

CE IP20 with dedicated PSU LED

COLOURS



driver not included

for drivers and dimming technology, please refer to our Axo Light pricelist or contact our representatives

hole Ø 5.5
 min depth 10 cm

Stormy

design Manuel Vivian

Collection of ceiling or wall lamps with metal frame and removable, washable elastic fabric covering. Screw fitting light source.
Collezione di lampade da soffitto o da parete con struttura metallica e rivestimento in tessuto elasticizzato, sfoderabile e lavabile. Sorgente luminosa con attacco a vite.

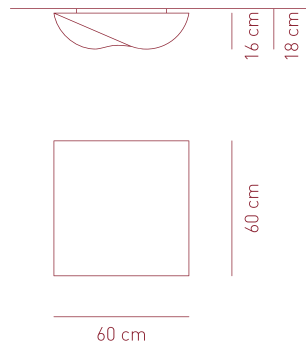

PL STOR 60
application: both as ceiling or wall lamp

E27 2 x Max 16W LED or
 2 x Max 70W halo

CE **IP20 +LED**

COLOURS

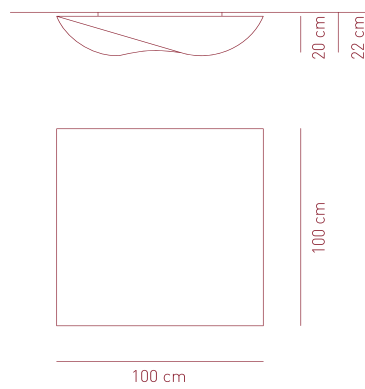

PL STO 100
application: both as ceiling or wall lamp

Source:
E27 3 x Max 16W LED or
 3 x Max 70W halo

CE **IP20 +LED**

COLOURS



U-light

design Timo Ripatti

Collection consisting of wall lamps, ceiling lamps and suspended lamps in aluminium. Built-in LED dimmable light source.
Collezione composta da lampade da parete, lampade da soffitto e lampade a sospensione in alluminio. Sorgente luminosa a LED integrato dimmerabile.

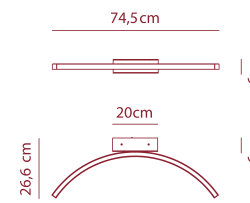

AP ULI 090
**application: downlight or
 upright mounting**

Source:

LED 17W - diffused beam - 3000K
 CRI 90 - ~1332 lm - 78 lm/W

CE **IP20** **LED**
 dimmable 1-10V

COLOURS

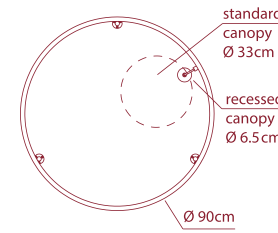
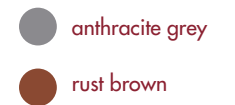

PL UL X 090
**application: both as ceiling
 (downlight or upright mounting) or wall
 lamp (only wallward light)**

Source:

LED 57,6W - diffused beam - 3000K
 CRI 90 - ~4413 lm - 77 lm/W

CE **IP20** **LED**



COLOURS

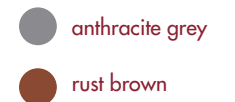

for drivers and dimming technology,
 please refer to our Axo Light pricelist
 or contact our representatives

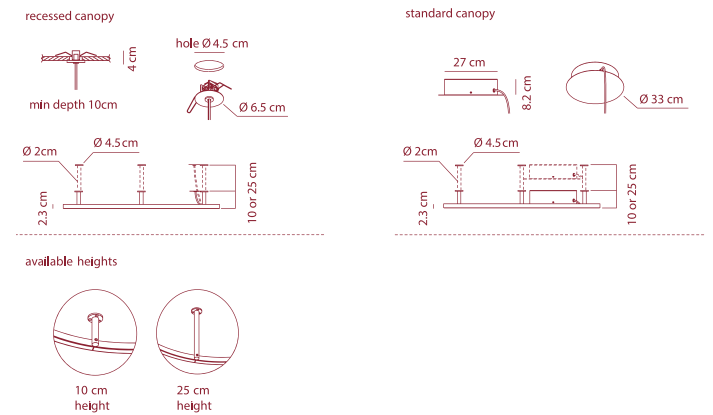

U-light

design Timo Ripatti

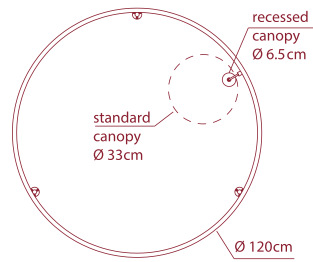

Collection consisting of wall lamps, ceiling lamps and suspended lamps in aluminium. Built-in LED dimmable light source.
 Collezione composta da lampade da parete, lampade da soffitto e lampade a sospensione in alluminio. Sorgente luminosa a LED integrato dimmerabile.

PL UL X 120
application: both as ceiling (downlight or uplight mounting) or wall lamp (only wallward light)

Source:
LED 86,4W - diffused beam - 3000K
 CRI 90 - ~6618 lm - 77 lm/W

CE IP20 LED



for drivers and dimming technology, please refer to our Axo Light pricelist or contact our representatives

COLOURS

- anthracite grey
- rust brown

recessed canopy

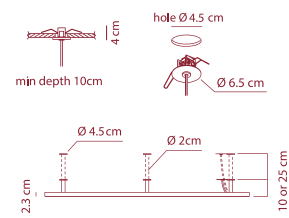

available heights

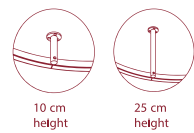

standard canopy

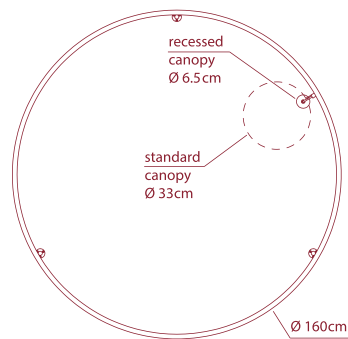
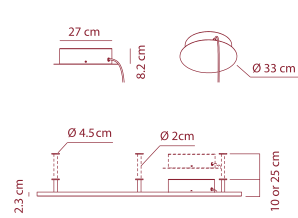

PL UL X 160
application: both as ceiling (downlight or uplight mounting) or wall lamp (only wallward light)

Source:
LED 108W - diffused beam - 3000K
 CRI 90 - ~8274 lm - 77 lm/W

CE IP20 LED



for drivers and dimming technology, please refer to our Axo Light pricelist or contact our representatives

COLOURS

- anthracite grey
- rust brown

recessed canopy

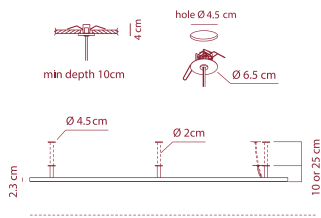

available heights

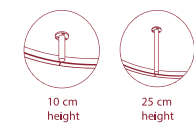

standard canopy

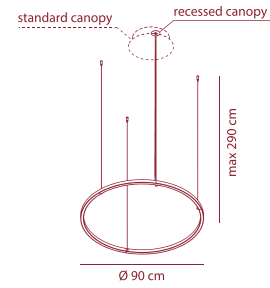
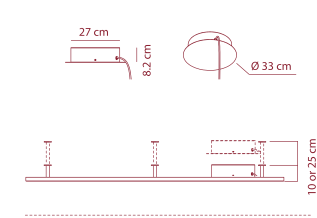

SP ULA 090

available with recessed or standard canopy

Source:
LED 57,6W - diffused beam - 3000K
 CRI 90 - ~4413 lm - 77 lm/W

CE IP20 LED



for drivers and dimming technology, please refer to our Axo Light pricelist or contact our representatives

COLOURS

- anthracite grey
- rust brown

recessed canopy

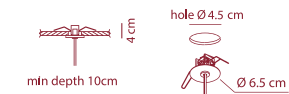

standard canopy

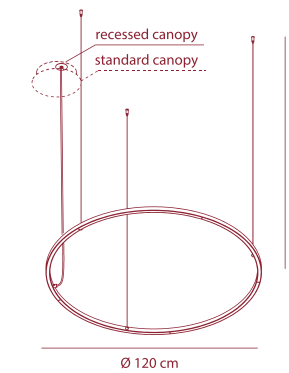

SP ULA 120

available with recessed or standard canopy

Source:
LED 86,4W - diffused beam - 3000K
 CRI 90 - ~6618 lm - 77 lm/W

CE IP20 LED



for drivers and dimming technology, please refer to our Axo Light pricelist or contact our representatives

COLOURS

- anthracite grey
- rust brown

recessed canopy

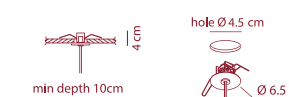

standard canopy



U-light

design Timo Ripatti

Collection consisting of wall lamps, ceiling lamps and suspended lamps in aluminium. Built-in LED dimmable light source.
Collezione composta da lampade da parete, lampade da soffitto e lampade a sospensione in alluminio. Sorgente luminosa a LED integrato dimmerabile.

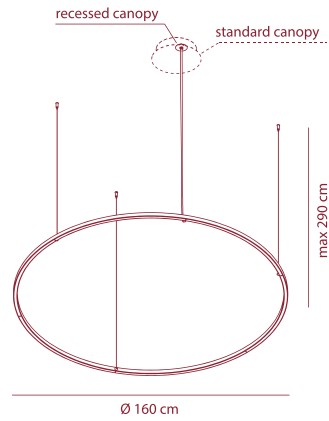

SP ULA 160

available with recessed or standard canopy

Source:
LED 107,8W - diffused beam - 3000K
 CRI 90 - ~8274 lm - 77 lm/W

CE IP20 LED



for drivers and dimming technology, please refer to our Axo Light pricelist or contact our representatives

COLOURS

- anthracite grey
- rust brown

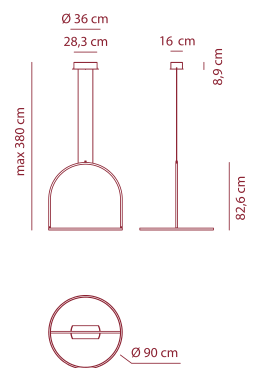
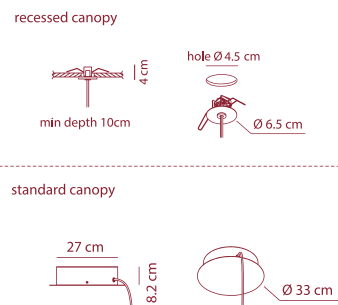

SP ULI 090

Source:
LED 57,6W - diffused beam - 3000K
 CRI 90 - ~4413 lm - 77 lm/W

CE IP20 LED

COLOURS

- anthracite grey
- rust brown

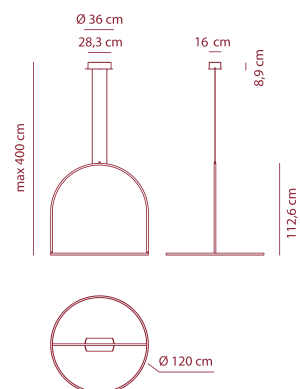

SP ULI 120

Source:
LED 86,4W - diffused beam - 3000K
 CRI 90 - ~6618 lm - 77 lm/W

CE IP20 LED

COLOURS

- anthracite grey
- rust brown

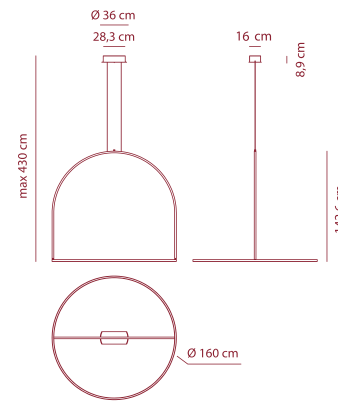

SP ULI 160

Source:
LED 108W - diffused beam - 3000K
 CRI 90 - ~8274 lm - 77 lm/W

CE IP20 LED

COLOURS

- anthracite grey
- rust brown

Ukiyo

design Manuel Vivian

Collection of ceiling or wall lamps with metal frame and white removable, washable elastic mesh fabric covering. Screw fitting light source.
Collezione di lampade da parete o da soffitto con struttura metallica e rivestimento in tessuto bianco retato elasticizzato, sfoderabile e lavabile. Sorgente luminosa con attacco a vite.

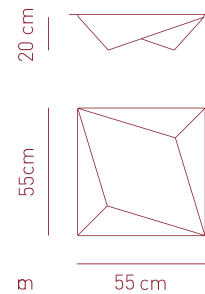

PL UKIYO P

Application: both as ceiling or wall lamp

COLOUR

- white

Source:
E27 3 x Max 6,5W LED or
 3 x Max 42W halo

CE IP20 +LED

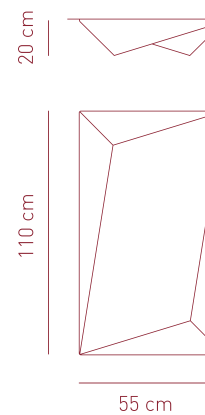

PL UKI 110

Application: both as ceiling or wall lamp

COLOUR

- white

Source:
E27 3 x Max 16W LED or
 3 x Max 70W halo

CE IP20 +LED

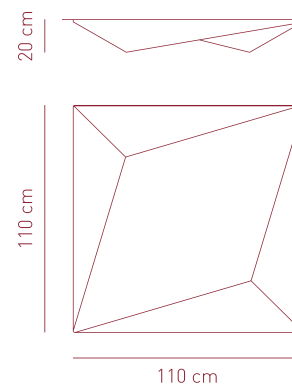

PL UKIYO G

Application: both as ceiling or wall lamp

COLOUR

- white

Source:
E27 3 x Max 16W LED or
 3 x Max 70W halo

CE IP20 +LED

Urban

design Dima Loginoff

Collection consisting of aluminium ceiling lamps and suspended lamps, also in a recessed version. Available in several colours and sizes. Built-in dimmable LED light source.

Collezione composta da lampade da soffitto e lampade a sospensione in alluminio. Disponibile in vari colori e dimensioni. Le sospensioni sono disponibili anche nella versione ad incasso. Sorgente luminosa a LED integrato dimmerabile.

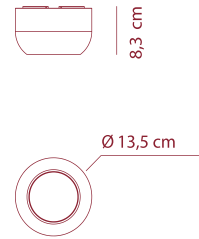

PL URBAN P

COLOURS

Source:

LED 15W - diffused beam - 3000K

CRI 90 - ~946 lm - 63 lm/W



○ wrinkled white ● matt bronze

● matt nickel

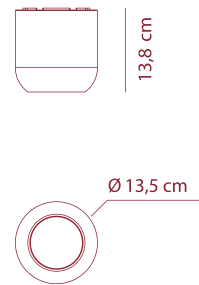

PL URBAN M

COLOURS

Source:

LED 15W - diffused beam - 3000K

CRI 90 - ~946 lm - 63 lm/W



○ wrinkled white ● matt bronze

● matt nickel

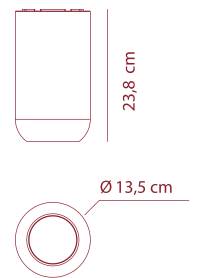

PL URBAN G

COLOURS

Source:

LED 15W - diffused beam - 3000K

CRI 90 - ~946 lm - 63 lm/W



○ wrinkled white ● matt bronze

● matt nickel

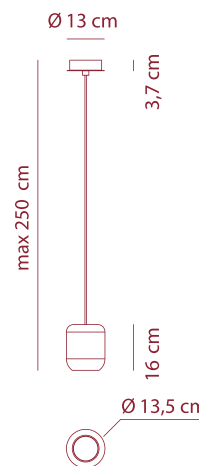

SP URBAN P downward lighting only

COLOURS

Source:

LED 15W - diffused beam - 3000K

CRI 90 - ~946 lm - 63 lm/W



○ wrinkled white ● matt bronze

● matt nickel

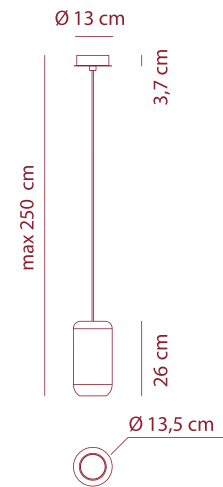

SP URBAN M downward lighting only

COLOURS

Source:

LED 15W - diffused beam - 3000K

CRI 90 - ~946 lm - 63 lm/W



○ wrinkled white ● matt bronze

● matt nickel

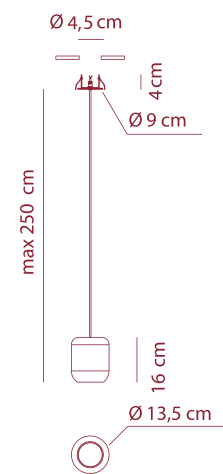

SP URBA P I recessed downward lighting only

COLOURS

Source:

LED 15W - diffused beam - 3000K

CRI 90 - ~946 lm - 63 lm/W



○ wrinkled white ● matt bronze

● matt nickel

hole Ø 4.5 cm
min depth 10 cm

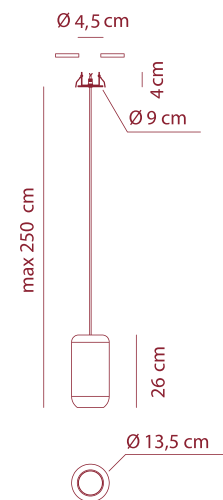

SP URBA M I recessed downward lighting only

COLOURS

Source:

LED 15W - diffused beam - 3000K

CRI 90 - ~946 lm - 63 lm/W



○ wrinkled white ● matt bronze

● matt nickel

hole Ø 4.5 cm
min depth 10 cm

Urban mini

design Dima Loginoff

Collection consisting of aluminium ceiling lamps and suspended lamps. Available in several colours and sizes Built-in dimmable LED light source.
 Collezione composta da lampade a sospensione e lampade da soffitto in alluminio. Disponibile in vari colori e dimensioni. Sorgente luminosa a LED integrato dimmerabile.

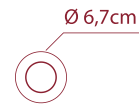

PL URBMI P

Source:
LED 8W - diffused beam - 3000K
 CRI 90 - ~409 lm - 51 lm/W



COLOURS

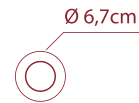
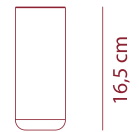

PL URBMI M

Source:
LED 8W - diffused beam - 3000K
 CRI 90 - ~409 lm - 51 lm/W



COLOURS

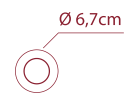

PL URBMI G

Source:
LED 8W - diffused beam - 3000K
 CRI 90 - ~409 lm - 51 lm/W



COLOURS

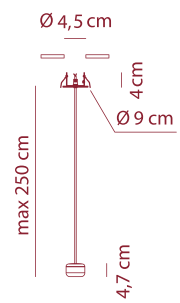

SP URMI P I recessed downward light only

Source:
LED 8W - diffused beam - 3000K
 CRI 90 - ~409 lm - 51 lm/W



hole Ø 4.5 cm
 min depth 10 cm

COLOURS

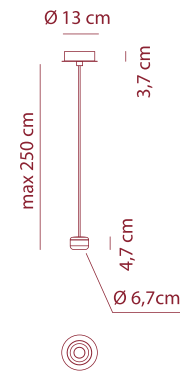

SP URBMI P downward light only

Source:
LED 8W - diffused beam - 3000K
 CRI 90 - ~409 lm - 51 lm/W



COLOURS

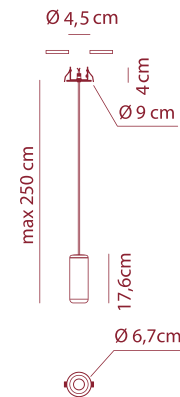

SP URMI M I recessed downward light only

Source:
LED 8W - diffused beam - 3000K
 CRI 90 - ~409 lm - 51 lm/W



hole Ø 7.5 cm
 min depth 10 cm

COLOURS

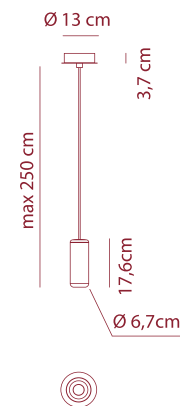

SP URBMI M downward light only

Source:
LED 8W - diffused beam - 3000K
 CRI 90 - ~409 lm - 51 lm/W



COLOURS

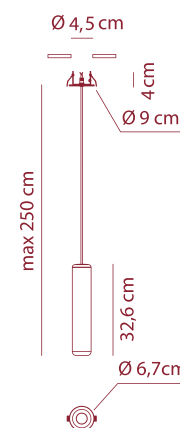

SP URMI G I recessed downward light only

Source:
LED 8W - diffused beam - 3000K
 CRI 90 - ~409 lm - 51 lm/W



hole Ø 4.5 cm
 min depth 10 cm

COLOURS



Urban mini

design Dima Loginoff

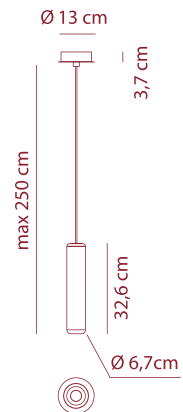

Collection consisting of aluminium ceiling lamps and suspended lamps. Available in several colours and sizes Built-in dimmable LED light source.
Collezione composta da lampade a sospensione e lampade da soffitto in alluminio. Disponibile in vari colori e dimensioni. Sorgente luminosa a LED integrato dimmerabile.

SP URBMI G downward light only

Source:
LED 8W - diffused beam - 3000K
CRI 90 - ~409 lm - 51 lm/W



COLOURS



Uriel

design Manuel Vivian

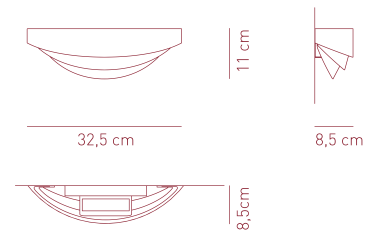

Collection of metal wall lamps in metal. Available in several colours. Light source with R7s fitting.
Collezione di lampade da parete in metallo, disponibile in vari colori. Sorgente luminosa con attacco R7S.

AP URIEL P

Source:
R7S 1 x Max 120W (78)



COLOURS

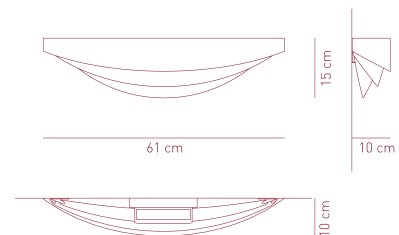

AP URIEL G

Source:
R7S 1 x Max 160W (118)



COLOURS



Vasily

design Manuel Vivian

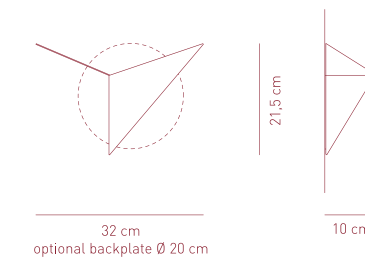

Wall lamp in metal. Available in several colours. Light source with G9 fitting.
Lampada da parete in metallo, disponibile in vari colori. Sorgente luminosa con attacco G9.

AP VASILY

Source:
G9 1 x Max 60W halo



COLOURS

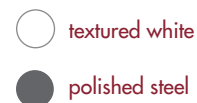

Velvet

design Manuel Vivian

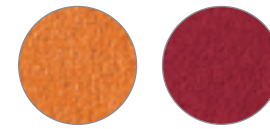

Collection consisting of ceiling lamps and suspended lamps. The cone-shaped lampshade is covered with a flame-retardant Micro 2000 fabric (polyester and cotton), which has a suede effect. Screw fitting or built-in dimmable LED light source.

Collezione di lampade a sospensione e lampade da soffitto con paralume troncoconico in tessuto ignifugato Micro 2000 (poliestere e cotone), effetto scamosciato. Sorgente luminosa con attacco a vite o a LED integrato dimmerabile.

COMPOSITION/COMPOSIZIONE
MICRO 2000 flame retardant fabric - 80% polyester + 20% cotton
Fleece finishing 100% polyester

Tessuto ignifugato MICRO 2000 - 80% poliestere + 20% cotone
Effetto scamosciato 100% poliestere

Glow Wire Test (EN 60598-1): 750 °C

WEIGHT/PESO
276 ± 5% gr/m²

AVAILABLE UPON REQUEST

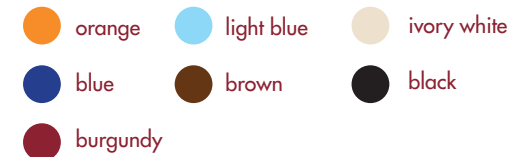

RADIAL DIFFUSER AVAILABLE UPON REQUEST

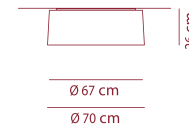

PL VEL 070

Source:
E27 2 x Max 16W LED or
2 x Max 20W fluo



COLOUR



RADIAL DIFFUSER



diffuser included

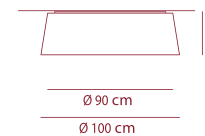

PL VEL 100

Source:
E27 3 x Max 16W LED or
3 x Max 33W fluo or
3 x Max 57W halo



COLOUR



RADIAL DIFFUSER



diffuser included

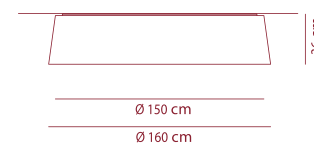

PL VEL 160

Source:
E27 5 x Max 16W LED or
5 x Max 23W fluo or
5 x Max 46W halo



COLOUR

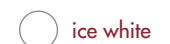

RADIAL DIFFUSER



diffuser included

Velvet

design Manuel Vivian

Collection consisting of ceiling lamps and suspended lamps. The cone-shaped lampshade is covered with a flame-retardant Micro 2000 fabric (polyester and cotton), which has a suede effect. Screw fitting or built-in dimmable LED light source.

Collezione di lampade a sospensione e lampade da soffitto con paralume troncoconico in tessuto ignifugato Micro 2000 (poliestere e cotone), effetto scamosciato. Sorgente luminosa con attacco a vite o a LED integrato dimmerabile.

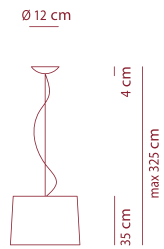

Ø 12 cm
4 cm
max 325 cm
35 cm
Ø 46 cm
Ø 50 cm

SP VEL 050

Source:
E27 1 x Max 16W LED or
1 x Max 23W fluo

CE IP20 +LED

diffuser included

COLOUR

ice white

RADIAL DIFFUSER

white

FINISH

white canopy

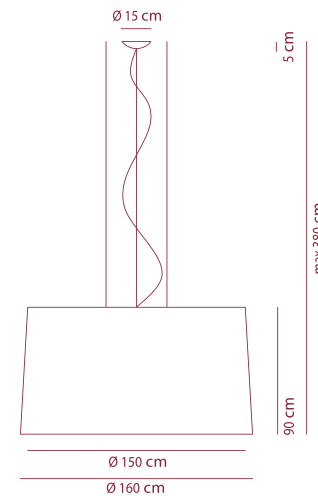

SP VEL 160 with upward & downward lighting

Source:

E27 4 x Max 16W + 1 x Max 9,5W LED or
5 x Max 23W fluo or
4 x Max 57W + 1 x Max 46W fluo

CE IP20

SP VEL 160 LED with upward & downward lighting

Source:

LED 95W - diffused beam - 3000K
CRI 90 - ~6096 lm - 64 lm/W

CE IP20 dimmable DALI LED

diffuser included

COLOUR

ice white

RADIAL DIFFUSER

white

FINISH

white canopy

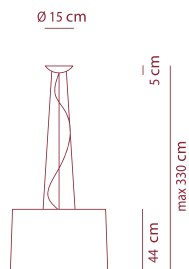

Ø 15 cm
5 cm
max 330 cm
44 cm
Ø 67 cm
Ø 70 cm

SP VEL 070

Source:
E27 1 x Max 20W LED or
1 x Max 33W fluo or
1 x Max 70W halo

CE IP20 +LED

diffuser included

COLOUR

ice white

RADIAL DIFFUSER

white

FINISH

white canopy

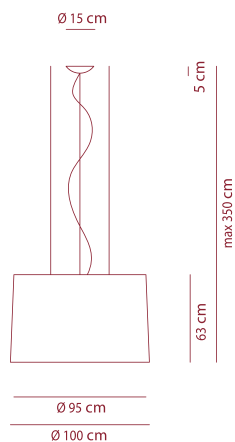

Ø 15 cm
5 cm
max 350 cm
63 cm
Ø 95 cm
Ø 100 cm

SP VEL 100 with upward & downward light

Source:
E27 4 x Max 20W LED or
4 x Max 33W fluo or
4 x Max 57W halo

CE IP20 +LED

SP VEL 100 LED with upward & downward light

Source:
LED 95W - diffused beam - 3000K
CRI 90 - ~6378 lm - 67 lm/W

CE IP20 dimmable DALI LED

diffuser included

COLOUR

ice white

RADIAL DIFFUSER

white

FINISH

white canopy

Virtus

design Manuel Vivian

Collection of suspended lamps in aluminium, also in a recessed version. Available in several colours. Built-in dimmable LED light source.

Lampade a sospensione in alluminio in vari colori. Disponibili anche nella versione ad incasso. Sorgente luminosa a LED integrato dimmerabile.

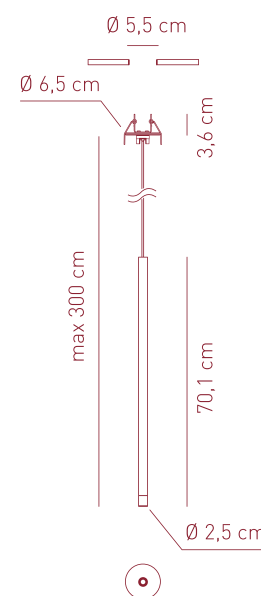
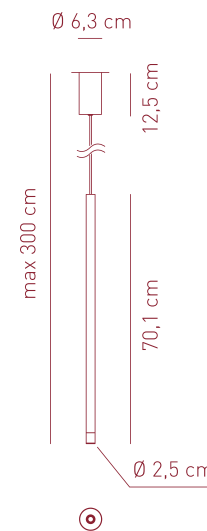

VIRTUS SUSPENSION mono canopy

Source:

LED 3W - 3000K
CRI 90 - ~184 lm - 61 lm/W

CE IP20 LED

VIRTUS SUSPENSION recessed version

Source:

LED 3W - 350mA - 3000K
CRI 90 - ~184 lm - 61 lm/W

CE IP20 with dedicated PSU LED

driver not included

for drivers and dimming technology,
please refer to our Axo Light pricelist
or contact our representatives

hole Ø 5.5 cm
min depth 10 cm

COLOURS

mat white

anthracite grey wrinkled
final: black polished nickel

anthracite grey wrinkled
final: polished gold

rust brown wrinkled
final: black polished nickel

rust brown wrinkled
final: polished gold

COLOURS

mat white

anthracite grey wrinkled
final: black polished nickel

anthracite grey wrinkled
final: polished gold

rust brown wrinkled
final: black polished nickel

rust brown wrinkled
final: polished gold

Voluptas

design Lorenzo Truant

Collection of white aluminium wall lamps and ceiling lamps with rubber-coated flexible rod. Available in several versions. Built-in LED light source.

Collezione di lampade da parete e da soffitto in alluminio bianco con asta flessibile rivestita in gomma. Disponibile in varie versioni. Sorgente luminosa a LED integrato.

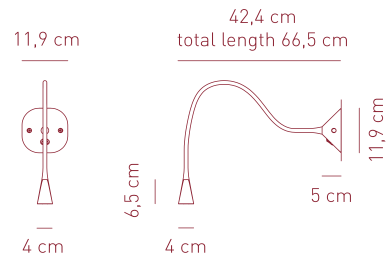

VOLUPTAS SWITCH WALL

Source:
LED 4W - diffused beam - 3000K
CRI 80 - ~226 lm - 56 lm/W

CE IP20 LED

COLOURS

○ matt white

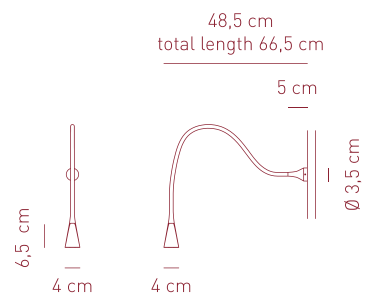

VOLUPTAS ARM WALL

Source:
LED 4W - 700 mA - diffused beam
- 3000K
CRI 80 - ~226 lm - 56 lm/W

CE IP20 LED

COLOURS

○ matt white

driver not included

for drivers and dimming technology, please refer to our Axo Light pricelist or contact our representatives

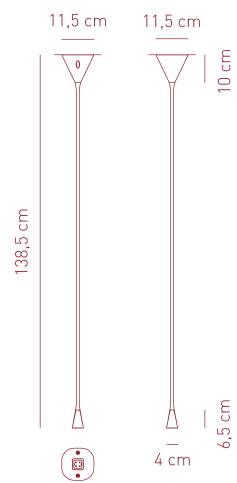

VOLUPTAS 140 CEILING

Source:
LED 16W - diffused beam - 3000K
CRI 80 - ~226 lm - 56 lm/W

CE IP20 LED

COLOURS

○ matt white

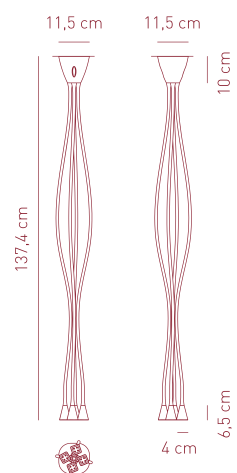

VOLUPTAS 4-140 CEILING









Source:
LED 16W - diffused beam - 3000K
CRI 80 - ~904 lm - 56 lm/W

CE IP20 LED

COLOURS

○ matt white

Legend

- LED** Integrated LED product
- LED** Product for LED light bulbs only
- +LED** Product for LED or conventional light bulbs
- CE** All our products undergo electric safety tests and comply with ECC Directive EN60598-1, LVD 2006/95/EC, EMC 2004/108/EC (where provided)
- CE Intertek** Product in conformity with Intertek certificate for European safety standards
-  Dimmable - dimmer included
-  Dimmable only with dedicated power supply unit
-  Interfaceable with DALI system
-  Dimmable 1-10V
-  Dimmable phase cut
- IPXY** Protection rating against solid bodies X
– against liquids Y
-  **Class 1**
Basic insulation, accessible conductors are earthed. Earthing is compulsory
-  **Class 2**
Double insulation. Earthing: excluded
-  **Class 3**
Appliance in which protection against electrical shock is guaranteed by the extremely low voltage power supply
- ADA** Product conforms to the USA A.D.A. standards (protruding objects)
- CRI Colour rendering index

Measures of the drawings in cm

Axo Light technical sheets and 3D files can be downloaded directly from our website: www.axolight.it

EEL compatibility

Axo Light – EELc Product List Energy Efficiency Label compatibility (EU Regulation 874/2012)

The Axo Light luminaires are compatible with bulbs – if available in the market and previously checked as regards their dimensions - labelled with the energy classes of the ENERGY LABELLING regulation.

The energy class letter in bold format is related to the bulb supplied together with the specific article.

The products with the symbol **LED** are equipped with built-in LED lamps A, A+, A++ that cannot be changed.

The information regarding the energy classes of the bulbs are not exhaustive about the actual while range available in the Economic European Area market

EELc CODE LIST PRODUCT CODE	EELc
LTAIBUXXXXXXG9L	A, A+, A++
SPALRISHXXXXE27	D, C, B, A, A+, A++
SPANAO90E27	D, C, B, A, A+, A++
SPANAO90FLE	A
SPANAI50E27	D, C, B, A, A+, A++
SPANAI50FLE	A
APAUAXXXXXXE27	D, C, B, A, A+, A++
PLAURAGXXXXXE27	D, C, B, A, A+, A++
PLAURAPXXXXXE27	D, C, B, A, A+, A++
PLAURG30XXXXE27	D, C, B, A, A+, A++
PLAURP30XXXXE27	D, C, B, A, A+, A++
SPAU45/2XXXXE27	D, C, B, A, A+, A++
SPAU60/2XXXXE27	D, C, B, A, A+, A++
SPAURA45XXXXE27	D, C, B, A, A+, A++
SPAURA60XXXXE27	D, C, B, A, A+, A++
SPAX20PIXXXG9X	D
APAX20GRXXXXG9X	D
APAX20PIXXXG9X	D
LTAX20XXXXXXG9X	D
PTAX20XXXXXXG9X	D
PLBEL060E27	D, C, B, A, A+, A++
PLBEL090E27	D, C, B, A, A+, A++
PLBEL118E27	D, C, B, A, A+, A++
PLBEL180E27	D, C, B, A, A+, A++
SPBEL045E27	D, C, B, A, A+, A++
SPBEL060E27	D, C, B, A, A+, A++
SPBEL090E27	D, C, B, A, A+, A++
SPBEL118E27	D, C, B, A, A+, A++
SPBEL180E27	D, C, B, A, A+, A++
APCLAV30XXXXE14	D, C, B, A, A+, A++
APCLAVBRXXXXE14	D, C, B, A, A+, A++
APCLAVGRXXXXE14	D, C, B, A, A+, A++
APCLAVPIXXXE14	D, C, B, A, A+, A++
LTCLAVIGXXXXE27	D, C, B, A, A+, A++
LTCLAVIPXXXXE14	D, C, B, A, A+, A++
LTCLAVXPXXXXE14	D, C, B, A, A+, A++
PLCLAV90XXXXE27	D, C, B, A, A+, A++
PLCLAVIUXXXXE27	D, C, B, A, A+, A++
PTCLAVIUXXXXE27	D, C, B, A, A+
SPCLA140XXXXE27	D, C, B, A, A+, A++
SPCLAV40XXXXE27	D, C, B, A, A+, A++
SPCLAV60XXXXE27	D, C, B, A, A+, A++
SPCLAVIPXXXXE27	D, C, B, A, A+, A++
SPCLAVIUXXXXE27	D, C, B, A, A+, A++
SPCLAVIUXXXXFLE	A, A+
SPCL6040XXXXE27	D, C, B, A, A+, A++
SPEXPL10XXXXR7S	D
SPEXPLI5XXXXR7S	D
SPEXPLO5XXXXR7S	D
SPEXPLOXXXXR7S	D
SPEXPQ10XXXXR7S	D
PLEULEGMFLE	A
PLEULEGPFLE	A
PLEULEMPFLE	A
PLEULERGFLE	A
PLEULERMFLE	A
PLEULERPFLE	A
PLEULGMPFLE	A
FAMENCARXXXX12V	C, B
FAMENCARXXXXG9X	D

EELc CODE LIST PRODUCT CODE	EELc
FANASHIRXXXX12V	C, B
FANASHIRXXXXG9X	D
FAFEDORAXXXGU1	A, A+, A++
SPFEDO12XXXXGU1	A, A+, A++
SPFEDOR1XXXXGU1	A, A+, A++
SPFEDOR3XXXXGU1	A, A+, A++
SPFEDOR6XXXXGU1	A, A+, A++
SPFEDOR7XXXXGU1	A, A+, A++
SPLAYAXXE27	D, C, B, A, A+, A++
SPLAYBXXE27	D, C, B, A, A+, A++
SPLAYCXXE27	D, C, B, A, A+, A++
SPLAYDXXE27	D, C, B, A, A+, A++
SPLAYEXXE27	D, C, B, A, A+, A++
SPLAYFXXE27	D, C, B, A, A+, A++
APMELTINXXXXE27	D, C, B, A, A+, A++
PTMELT55XXXXE27	D, C, B, A, A+, A++
PTMELT805NAXXE27	D, C, B, A, A+, A++
SPMEL115XXXXE27	D, C, B, A, A+, A++
SPMEL120XXXXE27	D, C, B, A, A+, A++
SPMELT55XXXXE27	D, C, B, A, A+, A++
SPMELT60XXXXE27	D, C, B, A, A+, A++
SPMELT80XXXXE27	D, C, B, A, A+, A++
LTMUSEGXXXXE27	E, D, C, B, A
LTMUSEPXXXXE14	D, C, B, A, A+, A++
PLMU120QXXXXE27	
+KPLMUSE	A, A+, A++
PLMUS120XXXXE27	
+KPLMUSE	A, A+, A++
PLMU120QXXXXE27	D, C, B, A, A+, A++
PLMUS120XXXXE27	D, C, B, A, A+, A++
PLMUS60QXXXXE27	D, C, B, A, A+, A++
PLMUSE40XXXXE27	D, C, B, A, A+, A++
PLMUSE60XXXXE27	D, C, B, A, A+, A++
PLMUSE80XXXXE27	
+KPLMUSE	A, A+, A++
PLMUSE80XXXXE27	D, C, B, A, A+, A++
SPMUSEXXXXE27	D, C, B, A, A+, A++
PLNAFI3XXXX12V	A, A+, A++
PLNAFIR3XXXXGU1	A, A+, A++
SPNAFIR1XXXXGU1	A, A+, A++
SPNAFIR3XXXXGU1	A, A+, A++
PLNEC100XXXXE27	D, C, B, A, A+, A++
PLNEL140XXXXE27	D, C, B, A, A+, A++
PLNEL60XXXXE27	D, C, B, A, A+, A++
PLNELS60XXXXE27	D, C, B, A, A+, A++
PLNES100XXXXE27	D, C, B, A, A+, A++
PLNES140XXXXE27	D, C, B, A, A+, A++
SPPLU080E27	D, C, B, A, A+, A++
SPPLU120E27	D, C, B, A, A+, A++
SPPLU180E27	D, C, B, A, A+, A++
PTPLU180E27	D, C, B, A, A+, A++
SPSKI070E27	A, A+, A++
SPSKI100E27	A, A+, A++
SPSKI160E27	A, A+, A++
PLSKI070E27	A, A+, A++
PLSKI100E27	A, A+, A++
PLSKI160E27	A, A+, A++
PLSKR070E27	D, C, B, A, A+, A++
SPSK100E27	D, C, B, A, A+, A++
SPSK150E27	D, C, B, A, A+, A++

PRODUCT CODE	EELc
PLSK1002E27	D, C, B, A, A+, A++
PLSK1502E27	D, C, B, A, A+, A++
PLSKR100E27	D, C, B, A, A+, A++
PLSKR150E27	D, C, B, A, A+, A++
APSKR028FLE	A
SPSKR050E27	D, C, B, A, A+, A++
SPSKR070E27	D, C, B, A, A+, A++
SPSKR100E27	D, C, B, A, A+, A++
SPSKR140E27	D, C, B, A, A+, A++
SPSKR150E27	D, C, B, A, A+, A++
LTSKR050E27	D, C, B, A, A+, A++
PLSPILGIXXX12V	C, B
PLSPILGIXXXG4L	A, A+, A++
PLSPILMIXXX12V	C, B
PLSPILMIXXXG4L	A, A+, A++
PLSPILPIXXX12V	C, B
PLSPILPIXXXG4L	A, A+, A++
APSPILLRXXX12V	C, B
APSPILLRXXXG4L	A, A+, A++
SPSPIL10XXX12V	C, B
SPSPIL10XXXG4L	A, A+, A++
SPSPIL12XXX12V	C, B
SPSPIL12XXXG4L	A, A+, A++
SPSPIL20XXX12V	C, B
SPSPIL26XXX12V	C, B
SPSPIL30XXX12V	C, B
SPSPILGIXXX12V	C, B
SPSPILGIXXXG4L	A, A+, A++
SPSPILL3XXX12V	C, B
SPSPILL3XXXG4L	A, A+, A++
SPSPILL6XXX12V	C, B
SPSPILL6XXXG4L	A, A+, A++
SPSPILLGXXX12V	C, B
SPSPILLGXXXG4L	A, A+, A++
SPSPILLMXXX12V	C, B
SPSPILLMXXXG4L	A, A+, A++
SPSPILLPXXX12V	C, B
SPSPILLPXXXG4L	A, A+, A++
SPSPILMIXXX12V	C, B
SPSPILMIXXXG4L	A, A+, A++
SPSPILPIXXX12V	C, B
SPSPILPIXXXG4L	A, A+, A++
SPSPIRYXXXXE27	D, C, B, A, A+, A++
PLSTO100XXXXE27	D, C, B, A, A+, A++
PLSTOR60XXXXE27	D, C, B, A, A+, A++
PLVEL070E27	D, C, B, A, A+, A++
PLVEL100E27	D, C, B, A, A+, A++
PLVEL160E27	D, C, B, A, A+, A++
PLUKI110XXXXE27	D, C, B, A, A+, A++
PLUKIYOGXXXXE27	D, C, B, A, A+, A++
PLUKIYOPXXXXE27	D, C, B, A, A+, A++
APURIELGXXXXR7S	D, C
APURIELPXXXXR7S	D, C
APVASILYXXXXG9X	D
SPVEL050E27	D, C, B, A, A+, A++
SPVEL070E27	D, C, B, A, A+, A++
SPVEL100E27	D, C, B, A, A+, A++
SPVEL160E27	D, C, B, A, A+, A++
SPVEL160FLE	A

Catalogue image credits

All photos by @shutterstock unless otherwise stated

intro, left hand page

art images in collage:

©2017 Fine Art Images/Heritage Images/Scala, Florence, Italy
Rachel Ruysch “Nature morte aux fruits et au bouquet de fleurs” 1703

©2017 Veneranda Biblioteca Ambrosiana/DeAgostini Picture Library/Scala, Florence, Italy
Jan Bruegel the Elder, “Vase of Flowers with Jewellery, Coins and Shells” 1606

©2017 White Images/Scala, Florence, Italy
Ambrosius Bosschaert, the Elder “Still Life with flowers” 1614

p. 12

Villa / Lucern, Switzerland
Design: Philippe Stuebi Architekten, Zürich
Photography: Dominique Marc Wehrli

p. 17

Zen Barn / Ottawa, Canada
Design: Rick Shean
Specifier: Christopher Simmonds Architect Inc.

p. 21

Showroom
Photos: Studio 7 srl – Pieve di Soligo (TV), Italy

p. 22

D-Hotel Maris Lobby / Marmaris, Turkey
Design: MidekMingu
Photography: Cemal Emden

p. 31

Showroom Bonaldo SPA, www.bonaldo.it

p. 38

Nhow Bar / Milan, Italy
Design: Karim Rashid
Photography: Giuseppe Creti

p. 50

Design: Luciana Bueno, Viviana Monari from “ID design for all”
Photography: Fernando Napolitano

p. 55

Terrazza Aperol / Il Mercato del Duomo / Milan, Italy
Design: Antonio Picuolo

p. 56

Hotel Nira Montana / La Thuile / Valle d’Aosta
Project by: Studio Del Portico HYPERLINK www.studiodelportico.it
Photography: Andrea Martiradonna www.martiradonna.it

p. 75

Yacht Soya
Design: Studio A-LAB Arch.
Marina Grasso, Federica Giovannone www.alabmarine.it

p. 56; 82; 105; 136; 137;

Private residence, 2016 / Treviso, Italy
Design: Andrea Rossetti, architect
Photography: Romandini Florindo

p. 107

W.O.K., World Oriented Kitchen / Rome, Italy
Design: Colli + Galliano Architetti
Lighting Design: Illuminati di G. Ippoliti
Photography: Matteo Piazza

p. 111; 120

Project: Agnieszka Cuprys - Wilk studio Archissima / Cracovia, PL
Interior design: Marek Wilk
Photography: Przemyslaw Kucinski www.niewformie.pl

p. 123-124; 190

Eneco Headquarter / Rotterdam, The Netherlands
Project: Hofman Dujardin Architects
Interior Designer: Fokkema & Partners Studio
Lighting Design: Studio Rublek
Photography: Matthijs van Roon

p. 126; 234

100% Capri Store/ Miami, USA
www.100x100capri.it
Design and photography: Paolo Giachi
www.paologiachi.it/it

p. 135

Hotel Scandic Tampere Station / Tampere, Finland
Design: dSIgn Vertti Kivi & Co., Sabina Dontcheff’s team
Photography: Okko Oinonen

p. 149

Showroom
Photography: Studio 7 srl – Pieve di Soligo (TV), Italy

p. 167

Apartment Nahimovsky Avenue / Moscow, Russia
Design: Pro VS Studio www.provsstudio.ru
Interior designer: Veronika Sudnikova www.houzz.it/pro/veronikasudnikova/veronika-sudnikova
Photography: Sergey Morgunov

p. 176

Hotel Waldstätterhof / Brunnen, Svizzera

p. 181; 185

Double Tree by Hilton Hotel London / London, UK
Architecture and interior design: Bennetts Associates
Lighting design: Bennetts Associates with GIA Equation
Lighting supplier: Light Projects Ltd
Photography: ©Edmund Sumner

p. 186

Deloitte Headquarters at the Edge Building
Amsterdam, The Netherlands
Project by: PLP Architecture
Interior Design: Fokkema & Partners Studio
Lighting Project by: ETK Lighting
Photos: Lida Chaulet and Ronald Tilleman
Realization: OVG Real Estate

p. 188

Private Residence / Lodz Poland
Kuo Architects

p. 189

Just Fab Headquarters / El Segundo, California, USA
Project by: Ehrlich Architects
Interior Design Studio Moshiri Associates Inc
Photography: Terrance Williams

p. 196

Leo Burnett Headquarter / Moscow, Russia
Architects: Nefa Architects
Lighting Engineers: Spector LAB
Project Management: Daria Turkina, Maria Boyko
General Contractor: Atitoka
Photography: Alexey Knyazev

p. 198

ENCORE AT EASTMARK / Mesa, Arizona, USA
Design: Studio Dwell
Photography: CDP Commercial

p. 199

Estrel Congress & Messe Center at Estrel Hotel
Berlin, Germany
©Estrel Berlin www.estrel.com/en
Photography: Philip Koschel www.koschel.de

p. 209

Daimler AG, Mercedes-Benz, IAA 2013, Abt. BC/BP
Internationale Automobil Ausstellung (IAA)
Frankfurt, Germany
Project: TLD Planungsgruppe GMBH, Wendlingen
Photography: www.keller-fotografie.de

p. 210

4Midtown Residences/ Miami, USA
Design: rs3 Designs - Raymond Jimenez & Shannon Scott
Lighting Specified by: Planet Lighting - Luis Alejandro Blanco

p. 211 (top)

Golden Palace Hotel LLC
http://goldenpalace.am/en/Royal-Suite-hotels-in-armenia

p. 211 (bottom)

The Plaza Hotel / Istanbul, Turkey
Design: MidekMingu
Photography: Cemal Emden

p. 212

Studio Design Exclusiv
Chisinau, MD-2012, Republic of Moldova

p. 229

Restaurant Belvedere / Hergiswil, Switzerland
Design and photography by: Belvedere, Bel Etage_Ag

p. 230-231

Christ Juweliere / Kadewe - Berlin, Germany
Design: D&L Lichtplanung, Ulrich Wallmeier
and Köster gmbh & Co Kg
Photography: Stefan Dauth

p. 233

Hotel Myriad / Lisbon, Portugal
Hotel Myriad by Sana Hotels www.myriad.pt

creative direction/art direction/design/photo illustrations

TEIKNA DESIGN

Claudia Neri, creative/design director

Elisa Stagnoli, design assistant

editing and coordination

Fabrizio Cettina

printed and bound in Italy

Grafiche Antiga spa

Renderings

Nudesign srl

Zenzero & co

Neiko srl

photolito

Graficart Arti Grafiche srl

Fotolito Quattrifoglio

Studio Varianti

Studio Pointer

photocredits

Florindo Romandini

Studio Varianti

Studio Pointer

Bluemotion

Axo Light si riserva il diritto di apportare ai modelli, senza alcun preavviso, qualsiasi modifica ritenesse opportuna. Axo Light non risponde per eventuali danni a persone o cose causati da una non corretta installazione dei propri apparecchi d'illuminazione. I dati riportati sono puramente indicativi; è possibile che siano riportati degli errori di stampa.

Axo Light reserves itself the right to introduce any changes to its own models, without prior notice. Axo Light is not liable for injuries or damage due to the incorrect installation of its fixtures. The details given here are intended purely as guidance as errors may have occurred during the printing process. Le schede tecniche dei prodotti Axo Light sono scaricabili direttamente dal nostro sito: www.axolight.it

Axo Light technical sheets can be downloaded directly from our website: www.axolight.it

AXO LIGHT srl
via Moglianese, 44
30037 Scorzè (Venezia) Italy
t. +39 041 5845193
f +39 041 5845060
axolight@axolight.it
axolight.it

AXO LIGHT USA INC.
22 Shelter Rock Lane, Ste #104
Danbury, CT, 06810 USA
t +1 (203) 730 0452
f +1 (203) 730 0460
info@axolightusa.com
axolightusa.com

AXO LIGHT ASIA LIMITED
RM305-306, Office Building
No.2 Tiantaiyi Road
Science Town, Luogang District
510663 Guangzhou - PRC
t +86 20 38316571
f +86 20 38251165
axo.asia@axolight.asia
axolight.it

Axolight bespoke design

Italy
United States
China

axolight.it

