

B.lux

outdoor lighting

2019

Decorative
Lighting

Architectural &
Outdoor Lighting

AMS	8
Frame	10
Inn Side	12
Kanpazar	14
Lap Bench	16
Noray	18
Speers Outdoor	20
Tube	22
White House	24
Zen	26
Zen WR	28

outdoor lighting





ES Nuestra aventura empresarial comienza en 1980. Por aquel entonces, el concepto de diseño era aún vagamente interpretado en nuestro entorno, Euskadi. Esta circunstancia, junto a un escasísimo mercado local para este tipo de producto, nos llevó ya por aquel entonces a la internacionalización.

Salimos al mercado internacional con unos inmejorables compañeros de viaje: los diseñadores de nuestros productos. En 1980-1981 trabajamos con Guillermo Capdevilla, uno de los promotores del diseño en Euskadi. Él fue el creador de Blux System, una colección de luminarias que dio un giro en la estrategia de producto de B.lux.

La nostalgia y las tendencias del mercado nos llevan hoy, 39 años después, a reeditar esta familia de luminarias de formas sencillas, que siguen las directrices de la escuela inglesa de diseño. Regresamos, con orgullo, a nuestros orígenes.

La ubicación de nuestras instalaciones en un enclave natural privilegiado también deja huella en las luminarias que fabricamos. Luminarias como Keshi emplean materiales muy cotizados a nivel internacional, como el mármol negro de las canteras de Markina, ubicadas en las inmediaciones de nuestra fábrica, de 5.000 m².

Es precisamente esa condición de fabricantes, tan poco habitual hoy en día, la que nos permite imprimir un carácter especial a nuestros productos, a los que aplicamos los máximos procesos de fabricación en nuestras instalaciones.

También nuestra proximidad a Bilbao, convertida hoy en referente internacional de arquitectura y diseño, ha moldeado nuestro catálogo de iluminación, gracias a nuestra participación en proyectos de iluminación de referencia en la Ciudad del Diseño, según la UNESCO.

Es así como todas y cada una de las luminarias que componen nuestro catálogo tienen una historia y un por qué. Una historia que refuerza nuestra identidad, forjada a lo largo de 39 años de historia.

EN Our business adventure began in 1980. At that time the concept of design was only vaguely appreciated in our area: the Basque Country. This, together with a very scarce local market for this type of product, spurred us towards internationalisation at a very early stage.

We hit the international market with a set of indispensable collaborators: our product designers. In 1980-1981 we worked with Guillermo Capdevilla, one of the promoters of design in Euskadi. He was the creator of the Blux System, a collection of lamps that marked a shift in B.lux's product strategy.

Nostalgia and market trends prompt us today, 39 years later, to rerelease this family of lamps, defined by their simple shapes and conforming to the patterns of the English school of Design. Proudly returning to our origins. The location of our facilities, in a very special natural enclave, also makes its mark on the lamps we produce. Lamps like the Keshi employ materials that are internationally coveted, like black marble from the Markina quarry, located close to our 5,000 m² factory.

It is precisely our role as manufacturers, very unusual today, which allows us to endow our products with a special quality, as we employ the finest maxim manufacturing processes at our facilities.

Our proximity to Bilbao, which has become an international landmark city in the fields of Architecture and Design, has also shaped our lighting catalogue, thanks to our participation in high-profile lighting projects in the City of Design, according to UNESCO.

Thus, each and every one of the lamps making up our catalogue has a story and a reason for being. These stories reinforce our identity, forged over 39 years of history.

AMS



by David Abad



AMS 12

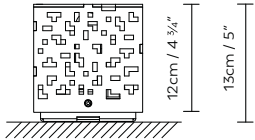

AMS 20

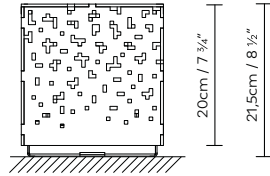

AMS 40

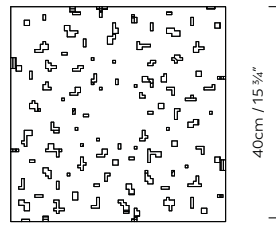
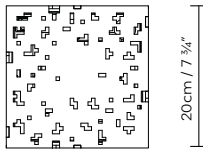
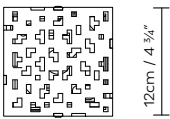
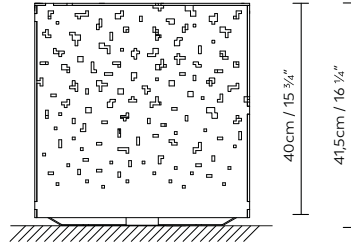

12cm / 4 3/4"

20cm / 7 3/4"

40cm / 15 3/4"

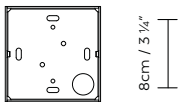

8cm / 3 1/4"

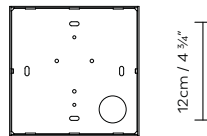

12cm / 4 3/4"

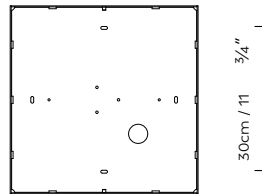

30cm / 11 3/4"

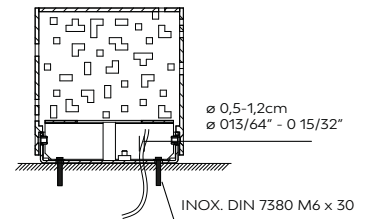

 Corten steel

 Stainless steel

12: LED 2,5W (G9)
Halo. max. 40W (G9)

20: LED 10W (E27)
Fluo. 18W (E27)
Halo. max. 60W (E27)

40: LED 13W (E27)
Fluo. 26W (E27)

Halo. max. 100W (E27)





Frame



by Mario Ruiz



L MANGUERA= S80cm / M100cm / L130cm
 S31 1/2" / M39 1/4" / L51 1/4"
 CABLE LENGHT= S80cm / M100cm / L130cm
 S31 1/2" / M39 1/4" / L51 1/4"
 KABELLÄNGE= S80cm / M100cm / L130cm
 S31 1/2" / M39 1/4" / L51 1/4"
 (Opción para realizar la conexión en la parte superior.
 Option to connect the light fitting at the top.
 Option für das Anschließen der Lampe im oberen Bereich.)

L MANGUERA= 10cm / 4"
 CABLE LENGHT= 10cm / 4"
 KABELLÄNGE= 10cm / 4"
 (Opción para realizar la conexión en la parte inferior,
 en el conector IP68.
 Option to connect the light fitting at the bottom,
 using the IP68 connector.
 Option für das Anschließen der Lampe mit
 IP68-Verbindungsstück im unteren Bereich.)

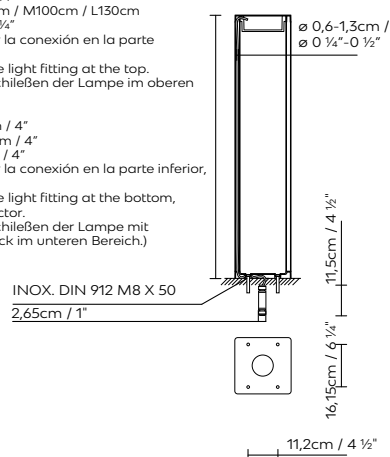

FRAME S

FRAME M

FRAME L

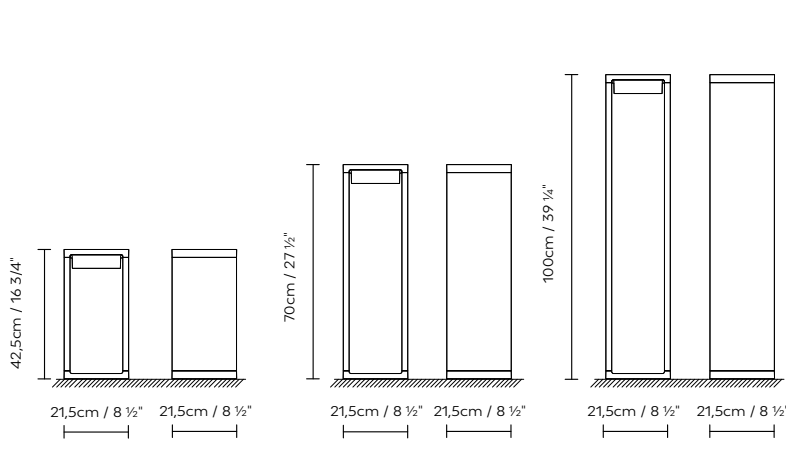

- White Satin
- Grey (Oxiron)
- Bronze
- Corten

- S LED: LED 17,5W 1550lm 3000K CRI>80 230V
- S FLUO: Fluo. 2 x 7W (2G7)
- M LED: LED 17,5W 1550lm 3000K CRI>80 230V
- M FLUO: Fluo. 2 x 7W (2G7)
- L LED: LED 17,5W 1550lm 3000K CRI>80 230V
- L FLUO: Fluo. 2 x 7W (2G7)



Inn Side



by Gemma Bernal

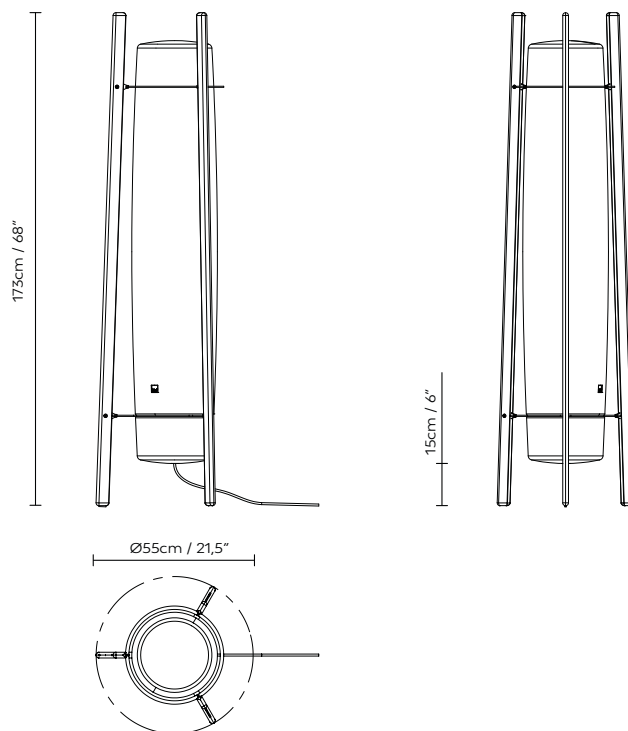
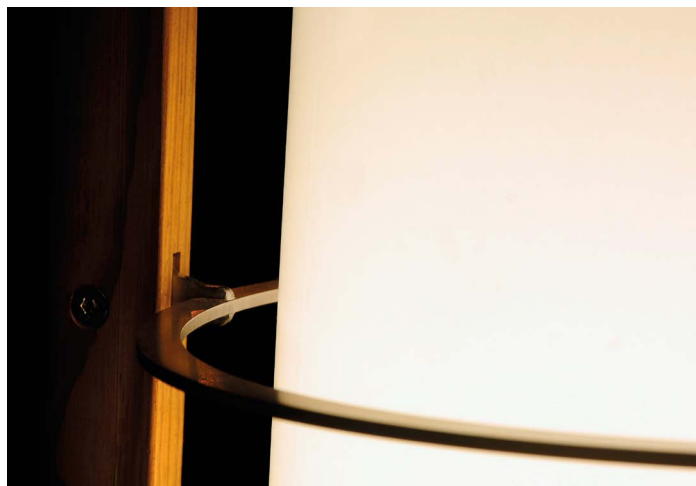

● ○ Radiata wood / Opal white

LED: LED 4 x 16W 10240lm 350mA 3000K 230V



Kanpazar



by Jon Santacoloma



Kanpazar

KANPAZAR 80A

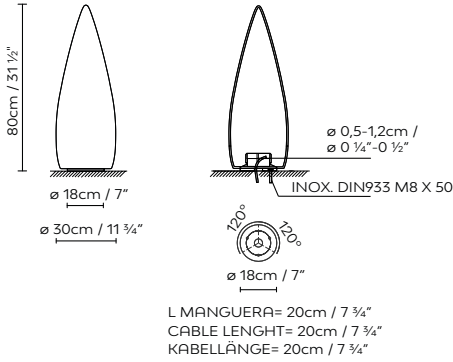

KANPAZAR 80B

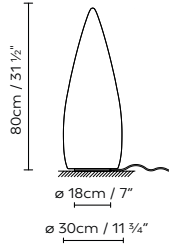

KANPAZAR 80C

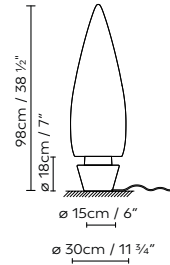

KANPAZAR 150A

KANPAZAR 150B KANPAZAR 150C KANPAZAR 150D

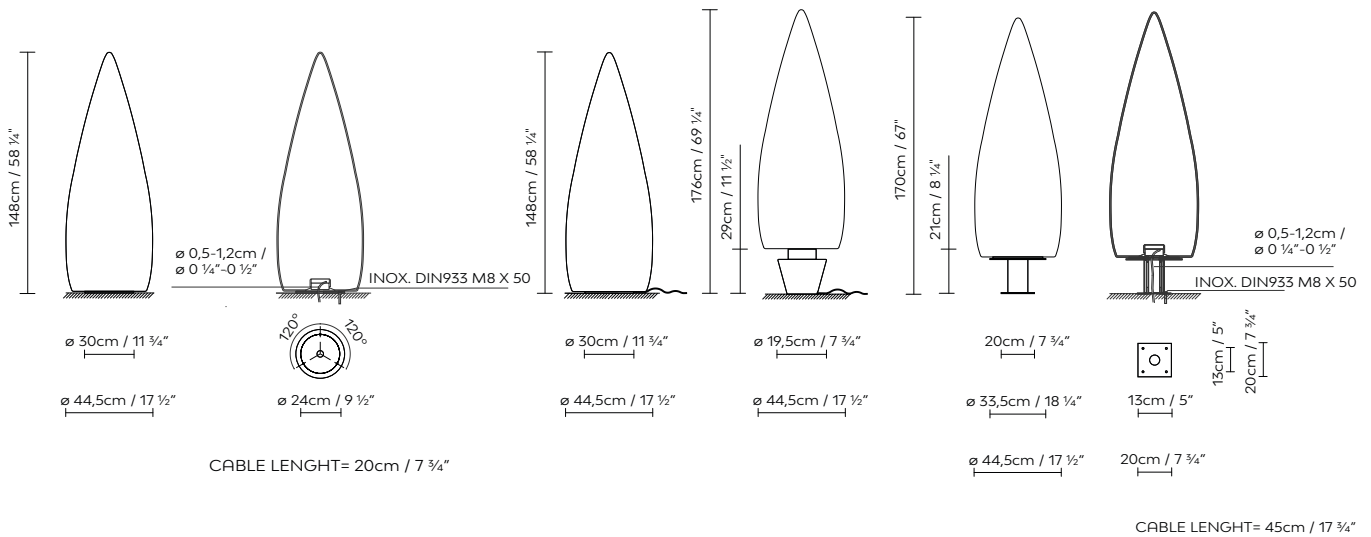

Opal white

80A/80B/80C LED:
80A/80B/80C FLUO:

LED 4 x 6W 4040lm 350mA 3000K CRI>80 230V
Fluo. 2 x 18/24/36W (2G11)

150A/150B/150C/150D LED:
150A/150B/150C/150D FLUO (2G11):

LED 4 x 12W 8040lm 350mA 3000K CRI>80 230V
Fluo. 2 x 55W (2G11)

150A/150B/150C/150D FLUO (G5):
*T5: White, red, blue, green

Fluo. 2 x 21W/39W (G5)*





Lap Bench



by David Abad



Lap Bench

LAP BENCH 45A LED / LAP BENCH 45B LED

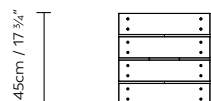
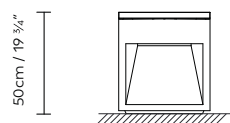

45cm / 17 3/4"

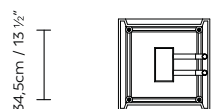

34,5cm / 13 1/2"

34,5cm / 13 1/2"

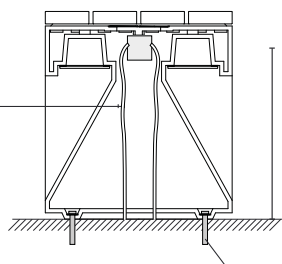

∅ 0,4 - 2cm
∅ 0 5/32" - 0 25/32"

L CABLE = 50cm / 19 3/4"
CABLE LENGTH = 50cm / 19 3/4"
KABELLÄNGE = 50cm / 19 3/4"

INOX. DIN 933 M8 X 50

LAP BENCH 45-2A LED / LAP BENCH 45-2B LED

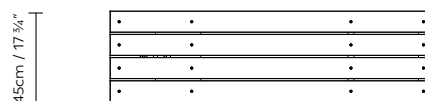
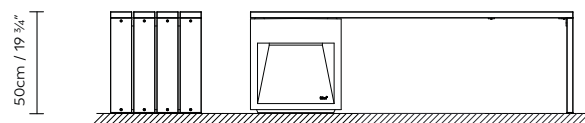

160cm / 63"

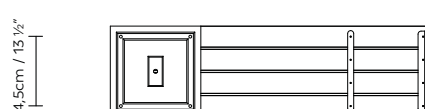

34,5cm / 13 1/2"

118,75cm / 46 3/4"

11cm / 4 1/4"
11cm / 4 1/4"
11cm / 4 1/4"

Concrete grey
satin

Rust

45A LED: LED 2 x 6,8W 630lm 3000K CRI>80 230V
45B LED: LED 2 x 6,8W 630lm 3000K CRI>80 230V
45-2A LED: LED 2 x 6,8W 630lm 3000K CRI>80 230V





Noray



by Josep Lluís Xuclà

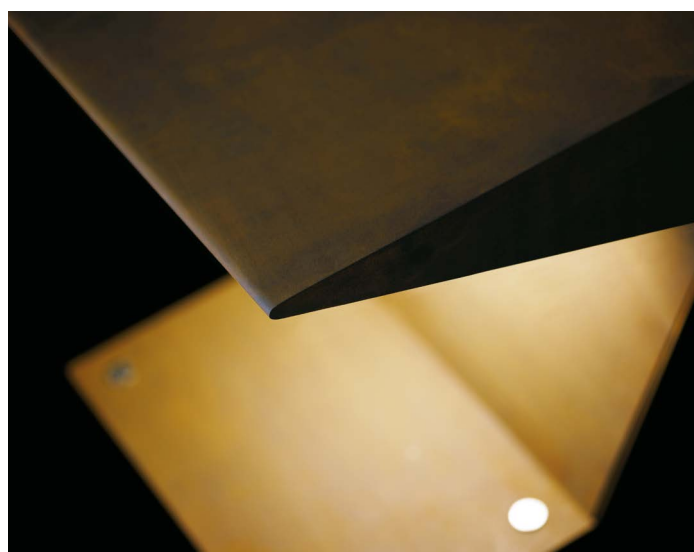
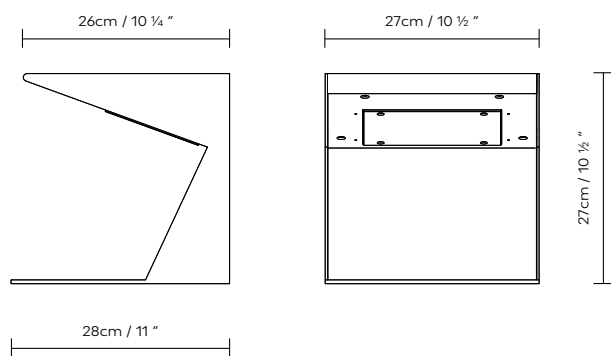

● Corten steel ● Stainless steel 316

LED: LED 2 x 6,3W 1680lm 350mA 3000K CRI80 230V



Speers Outdoor



by David Abad



Speers Outdoor

Speers Outdoor Light Source

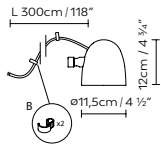

Speers Outdoor F Accessory

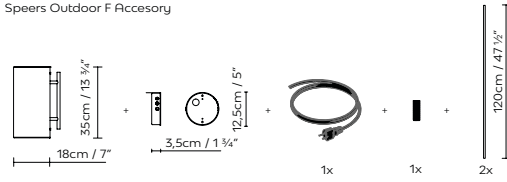

Speers Outdoor C Accessory

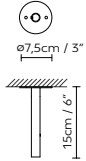

Speers Outdoor Angle Accessory (2x)

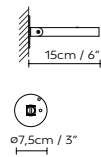

Speers Outdoor W Accessory

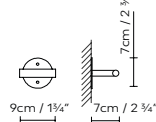

Speers Outdoor Stem Accessory 120 / 150

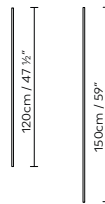

Speers Outdoor Connection Box

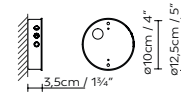

Samples

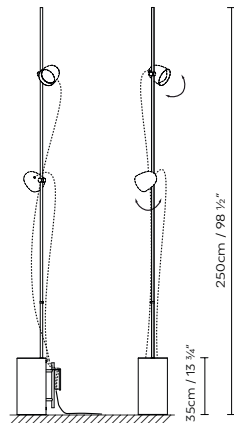

Sample 1: Speers Outdoor F Accessory + 2 Light Source

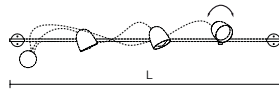

Sample 2: 2 Speers Outdoor W Accessory + 3 Light Source + Connection Box + Stem (L)

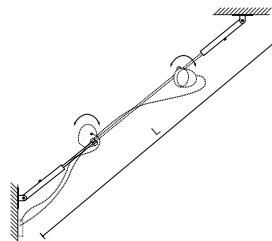

Sample 3: Speers Outdoor Angle Accessory + 2 Light Source + Connection Box + Stem (L)

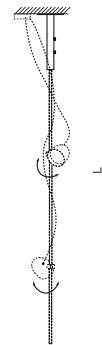

Sample 4: Speers Outdoor C Accessory + 2 Light Source + Connection Box + Stem (L)

*Max. 3 light sources per connection box.

● Black matte

○ White matte

LED: LED 7W 1080lm 2700K CRI80 230V





Tube

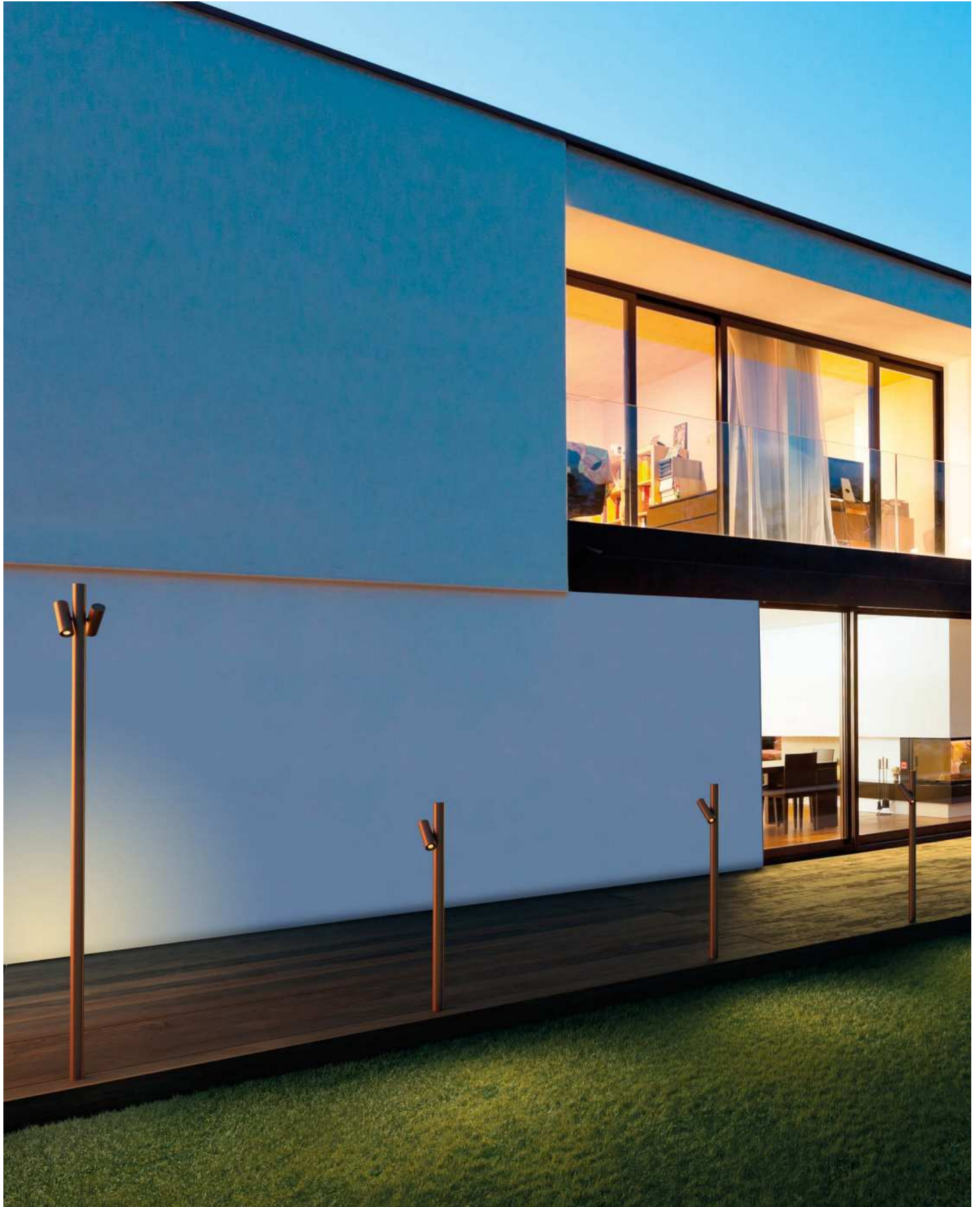

by Josep Lluís Xuclà

90-1

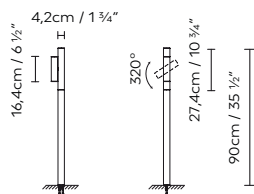

90-2

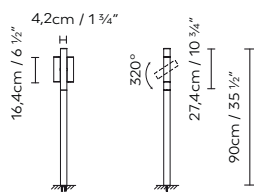

180-1

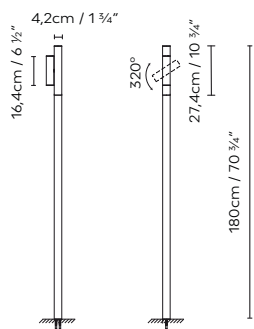

180-2

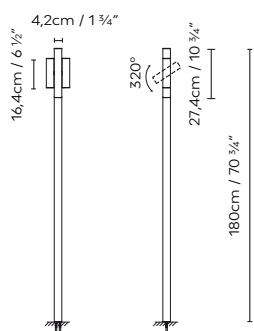

● Kakhi
satin

● Corten

90-1: LED 6,3W 840lm 350mA 3000K 110-230V
 90-2: LED 2 x 6,3W 1680lm 350mA 3000K 110-230V
 180-1: LED 6,3W 840lm 350mA 3000K 110-230V
 180-2: LED 2 x 6,3W 1680lm 350mA 3000K 110-230V



White House

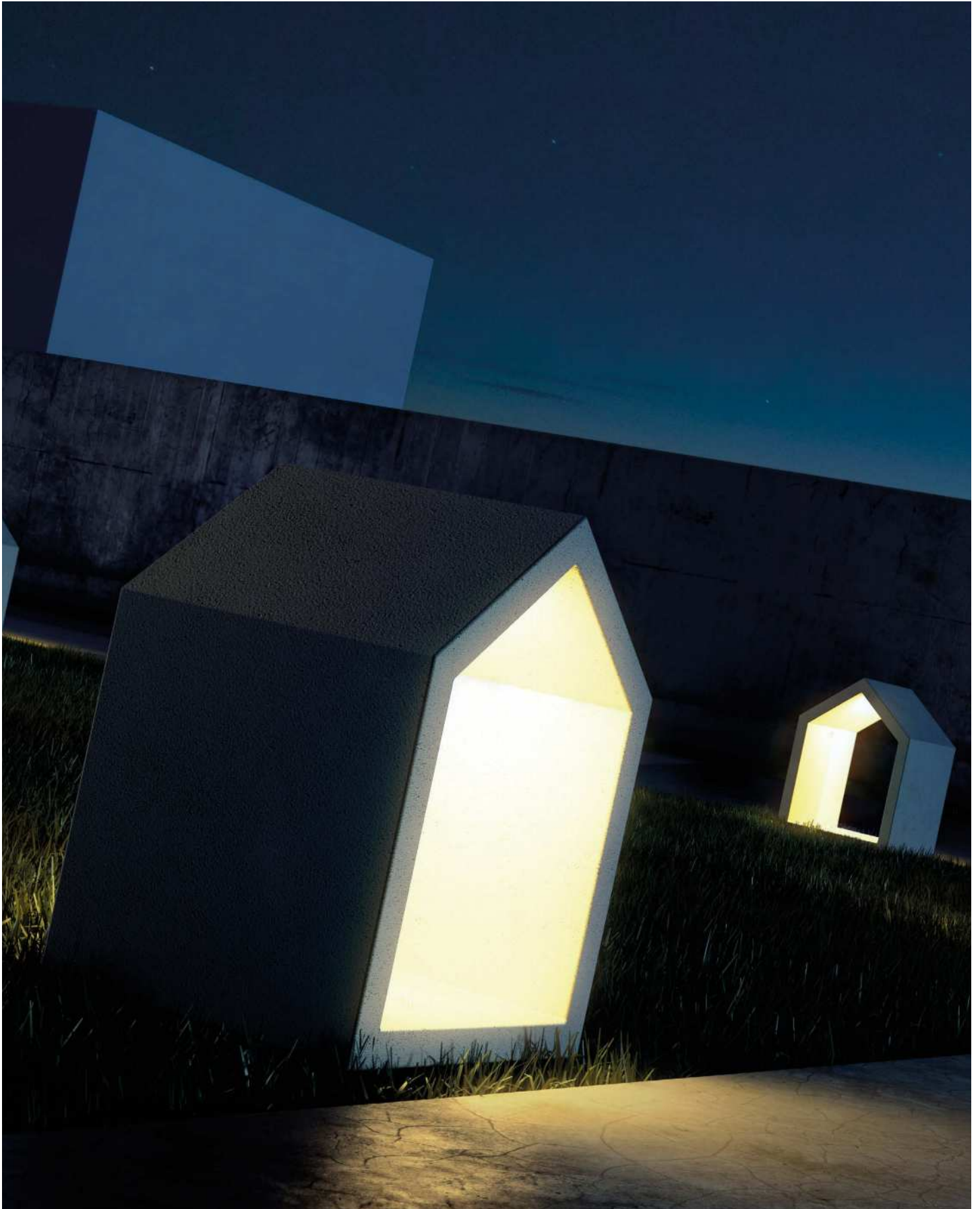

by David Abad

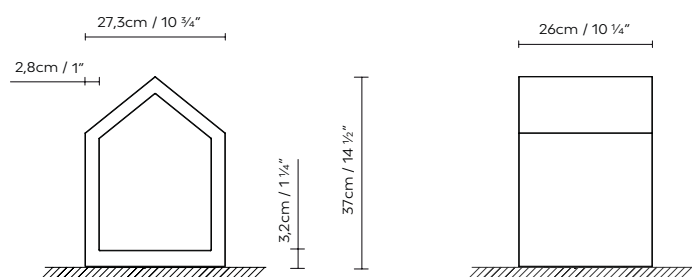

○ White

● Black

● Grey

LED: 2 x 4W 1280lm 350mA 3000K CRI>80 110-230V
* Optional, without gear.



Zen



by Martínez y Soler Arquitectos



LED: 6,3W 840lm 350mA 3000K 110-230V

● ● Corten steel / wood

● ● Stainless steel / Black marble Markina



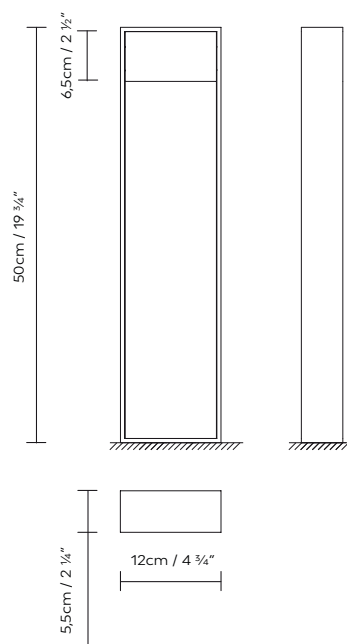

CE EAC

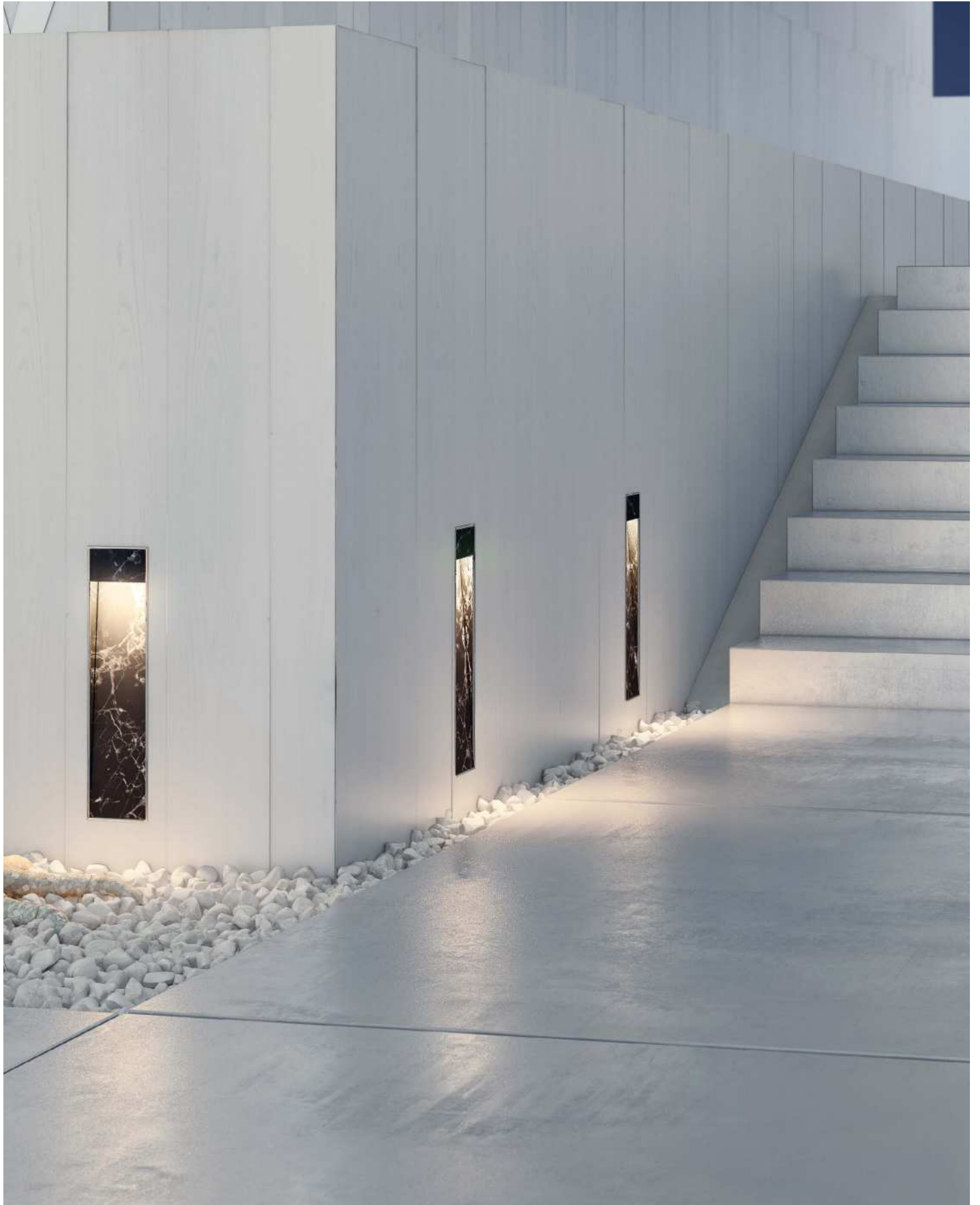

Zen WR

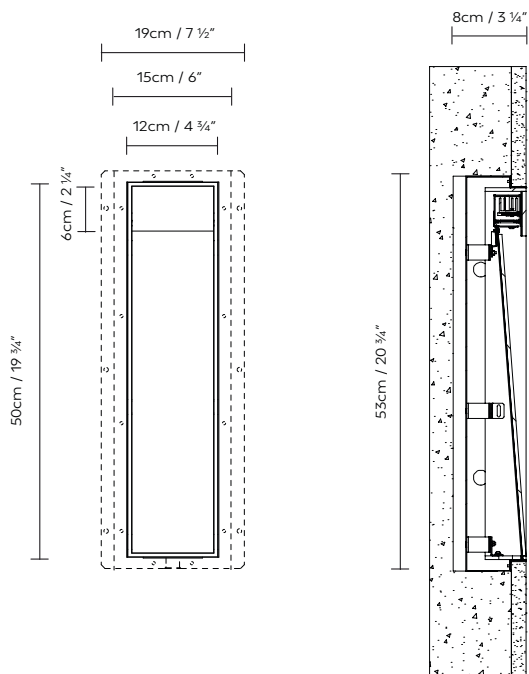
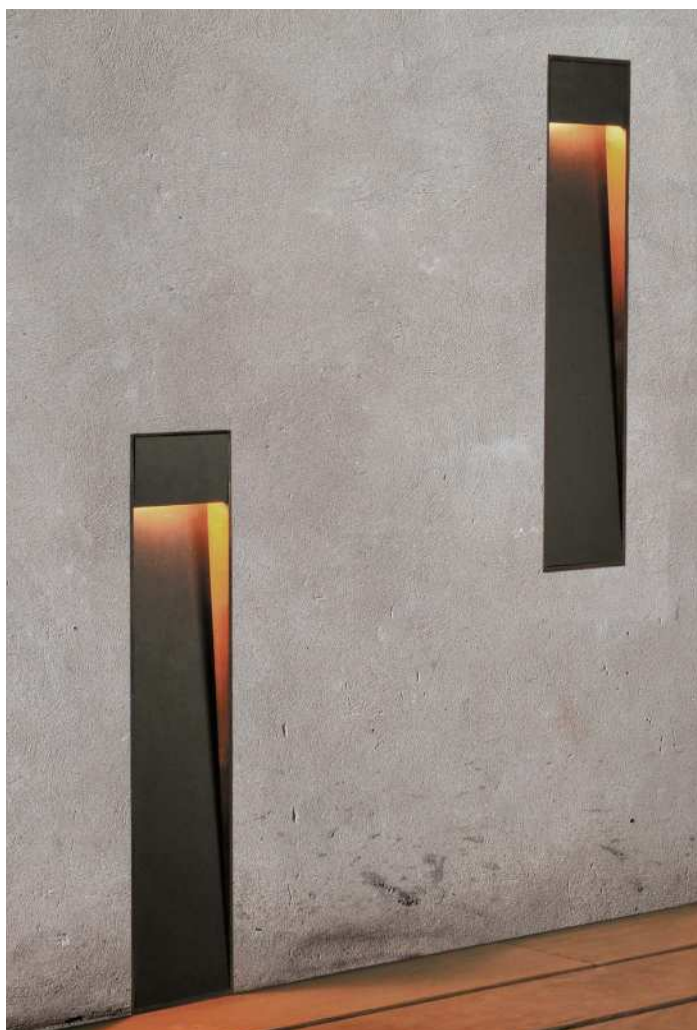

by Martínez y Soler Arquitectos



LED: 4,5W 656lm 250mA 3000K 230V

● ● Corten steel / wood

● ● Stainless steel / Black marble Markina



- | | | | |
|--|--|--|---|
|  RAL 3002 satin |  RAL 7044 text. |  RAL 9004 matte |  RAL 9010 text. |
|  RAL 7009 |  RAL 9001 |  RAL 9005 satin |  RAL 9011 matte |
|  RAL 7032 matte |  RAL 9003 satin |  RAL 9006 metalised |  RAL 9016 satin |
|  RAL 7032 satin |  RAL 9003 text. |  RAL 9007 text. |  RAL 9016 semi-shiny |

 Custom paint

 Luminaria de suspensión
Suspension lamp

 IP54 Degree of protection 54

 European norm

 Luminaria de pie
Floor lamp

 IP55 Degree of protection 55

 EAC certification

 Luminaria de mesa
Table lamp

 IP65 Degree of protection 65

 UL certification

 Luminaria de pared
Wall lamp

 Class I

 cUL certification

 Luminaria de techo
Ceiling lamp

 Class II

 Programme for the
Endorsement of Forest
Certification

B.lux S.A. se reserva el derecho de efectuar cualquier modificación y anulación de los productos y sus características técnicas, sin previo aviso.

B.lux S.A. reserves the right to make any modifications and remove products and their technical characteristics without prior notice.

