

LES
NOUVELLES
COLLECTIONS
JANVIER 2018

DCWéditions
PARIS

BINY

—

IN THE SUN

—

ITT 360°

—

**NOUVELLE
COLLECTION**

BINY de Jacques Biny —	06-43
IN THE SUN de Dominique Perrault et Gaëlle Lauriot-Prévost —	44-53
IN THE TUBE 360° de Dominique Perrault et Gaëlle Lauriot-Prévost —	54-65
MANTIS BS2 Mini de Bernard Schottlander —	66-71
NOUVELLE COLLECTION d'Éric de Dormael —	72-77

BINY™, IN THE SUN™, IN THE TUBE 360°™,
MANTIS™, LUNE™, BROCHE™, TRON™
are trademarks of DCW Entreprises

DCW éditions • Français

2018 : Déjà 9 années ont passé. L'aventure continue.

Nous parlons toujours d'objets et jamais de produits, toujours de l'objet compagnon du quotidien : bien pensé, bien dessiné, bien fabriqué et au juste prix. Nos fondamentaux n'ont pas bougé. Nos éditions ne cherchent pas à plaire à tout le monde, mais nous sommes assez nombreux dans ce monde pour permettre à ces objets particuliers d'exister. Nous sommes excités de vous présenter les "BINY" de Jacques Biny, la collection "atmosphérique" **IN THE SUN** et les nouveaux tubes **ITT 360°** avec des flaps et des wings de Dominique Perrault et Gaëlle Lauriot-Prévost, ainsi que le début de la **NOUVELLE COLLECTION** d'Éric de Dormael.

2008-2017 : **LA LAMPE GRAS** de Bernard-Albin Gras, la chaise **SURPIL** de Julien Porché, la collection **MANTIS** de Bernard Schottlander, **HERE COMES THE SUN** de Bertrand Balas, **IN THE TUBE** de Dominique Perrault et Gaëlle Lauriot-Prévost, les miroirs **MbE** et le dernier bijou, la lampe **ISP** de Ilia Sergeevich Potemine.

DCW éditions • English

2018: And the adventure goes on: we still refer to our output as objects, not products. It is a vision of the object as a companion to our daily existence: well-conceived, well-designed, well-made and at the right price. The fundamentals haven't changed. We're not out to please everybody, but we think there are enough of us here on the planet to let our objects find their audience. We're excited to present **BINY** by Jacques Biny, the "atmosphérique" collection from **IN THE SUN**, the new **ITT 360°** tubes with their flaps and wings designed by Dominique Perrault and Gaëlle Lauriot-Prévost, and the start of the **NEW COLLECTION** of Éric de Dormael.

2008-2017: Nine years have already gone by: and in that time we have produced **THE LAMPE GRAS** by Bernard-Albin Gras, the **SURPIL** chair by Julien Porché, the **MANTIS** collection from Bernard Schottlander, Bertrand Balas' **HERE COMES THE SUN**, **IN THE TUBE** by Dominique Perrault and Gaëlle Lauriot-Prévost, the **MbE** mirrors, and our latest jewel, the **ISP** lamp by Ilia Sergeevich Potemine.

DCW éditions • Deutsch

2018 : Das Abenteuer geht weiter.

Wir reden immer noch von Objekten und niemals von Produkten, immer von den Objekten als Alltagsbegleiter : gut durchdacht - gut entworfen - gut angefertigt und dies zu einem angemessenen Preis.

Unsere Klassiker haben sich nicht verändert und stets für Sie da. Unsere Auflagen sind nicht bestrebt jedem zu gefallen, doch sind wir zahlreich genug, um diesen ausgefallenen Objekten ein Dasein zu ermöglichen. Daher freuen wir uns Ihnen unsere neuesten Objekte vorstellen zu dürfen : die Leuchten "BINY" von Jacques Biny, die "atmosphärische" Kollektion **IN THE SUN**, die neuen Leuchtröhren **ITT 360°** von Dominique Perrault et Gaëlle Lauriot-Prévost sowie den Start einer **NEUE KOLLEKTION** von Éric de Dormael.

2008-2017 : Schon 9 Jahre sind vergangen. **DIE LAMPE GRAS** von Bernard-Albin Gras, der Stuhl **SURPIL** von Julien Porché, die Kollektion **MANTIS** von Bernard Schottlander, die Hängeleuchten **HERE COMES THE SUN** von Bertrand Balas, die Glasröhren-Leuchten **IN THE TUBE** von Dominique Perrault und Gaëlle Lauriot-Prévost, die Spiegel **MBE** und das letzte Schmuckstück, die Leuchte **ISP** von Ilia Sergeevich Potemine.

“

Français · Il y a des objets qui naissent du désir et de l'amour.
Il y a des objets qui disparaissent, soufflés par l'air du temps.

Être dans l'air du temps, c'est avoir le destin des feuilles mortes.
(Jean Guitton)

Seuls le beau et le juste sont éternels.

English · There are objects born from desire and objects born from love.
There are objects that disappear, scattered by the winds of time.

To be of one's time is to share the destiny of the dead leaves.
(Jean Guitton)

Only truth and beauty are eternal.

Deutsch · Es gibt Objekte, geboren aus Wünschen und Objekte, geboren aus Liebe.
Es gibt Objekte, die verschwinden, zerstreut von den Winden der Zeit.

Um einmal das Schicksal der toten Blätter zu teilen.
(Jean Guitton)

Nur die Wahrheit und Schönheit sind ewig.

”

DCW éditions
PARIS

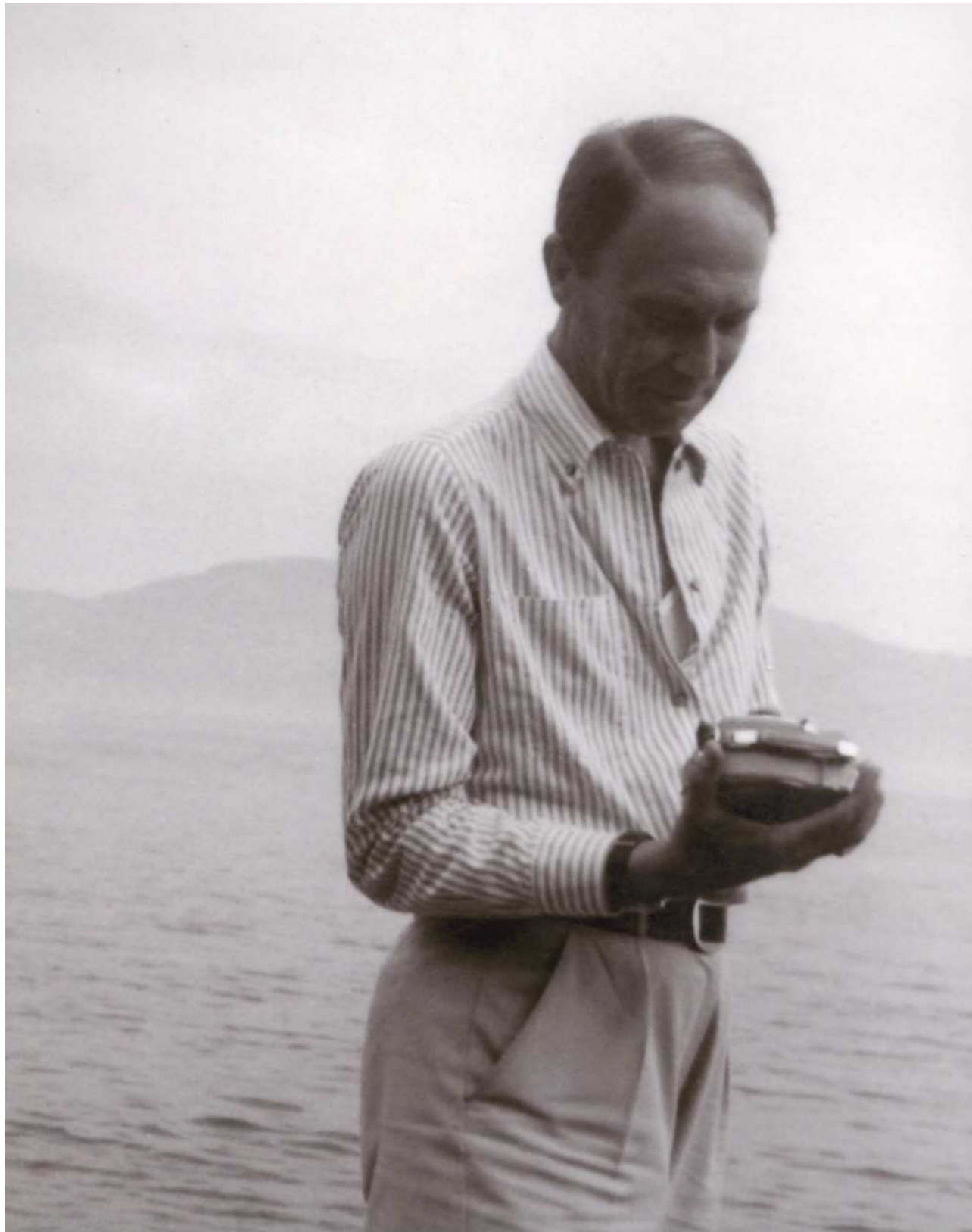

BINY™

de Jacques Biny

Français · Jacques Biny en 1955, fonde à Paris son atelier d'éclairage moderne Luminalite.

Moderne, précurseur, ce Designer-Éditeur né en 1913 développe sur 30 ans près de 400 modèles. Jacques Biny, est un homme rigoureux, qui n'a cessé de travailler pour améliorer le confort par la lumière dans l'habitat. La priorité donnée à la fonction, l'économie de moyen dans la recherche formelle suggèrent certains parallèles avec le courant artistique américain du Minimalisme apparut au milieu des années 60, ce qui explique l'engouement des collectionneurs autant aux États-Unis qu'en Europe.

Efficacité, simplicité, sobriété, élégance, refus de l'ostentatoire sont les dénominateurs communs du travail de Jacques Biny.

Ce sont pour ces qualités que nous avons choisi d'éditer les Box et le Spot de Jacques Biny.

English · In 1955, Jacques Biny opened Luminalite, his workshop for producing modern lighting.

Modern, before its time, the Designer-Manufacturer who was born in 1913 developed over 400 models during a 30 year career. Jacques Biny's hallmark was rigour and he never stopped in his quest to improve how homes were lit. Functionality was primary, the lack of superfluity in the form reminiscent of the minimalist movement that was gaining currency in American art during the 1960's, which may go to explain why his work

is as popular with American collectors as it is with Europeans.

Efficiency and simplicity, restraint, elegance and modesty are the common denominators in Jacques Biny's work.

They are the same qualities that inspired us to reproduce Jacques Biny's Box lights.

Deutsch · Jacques Biny, geboren 1913, gründet 1955 in Paris sein erstes Atelier "Luminalit" zur Herstellung moderner Leuchten. Dieser Designer und Verleger entwickelt als moderner Vorläufer rund 400 Modelle in 30 Jahren.

Jacques Biny ist ein gewissenhafter Mann, der unablässig arbeitet, um den Komfort des Lebensraumes durch die Beleuchtung zu verbessern. Die Priorität gilt der Funktion. Die Einsparung in der Formensuche evoziert einige Parallelen zur amerikanischen Stilrichtung des Minimalismus, aufgekommen in der Mitte der 60er Jahre. Diese Tatsache erklärt die Begeisterung für Biny's Modelle sowohl in Amerika als auch in Europa.

Effizienz, Schlichtheit, Zurückhaltung, Eleganz, betonte Unauffälligkeit sind die gemeinsamen Nenner der Werke Jacques Binnys.

Es sind diese Vorzüge, die uns ermutigt haben, die "Box de Lumière" von Jacques Biny zu verlegen.



BINY TABLE SW BL-WH

BINY TABLE™

de Jacques Biny

La lampe de table (Biny Table n°231) de Jacques Biny est presque un extra-terrestre dans le monde lunaire (pardon !) dans l'univers du luminaire. Certains évoquent un robot, d'autres un personnage de dessins animés et d'autres encore un objet minimaliste radicalement efficace. Créée en 1957, elle est toujours d'une grande modernité. Pour une bonne lecture, Biny l'a conçue avec des ailettes qui dirigent la lumière intense sur l'intégralité du plan utile. Pour un éclairage doux et étonnamment efficace, cette *réédition développée* utilise la technologie LED intégrée en 2700K avec des ailettes orientables grâce à une mollette.

réédition développée : La réédition n'est pas un regard dans le rétroviseur. Pour permettre à un objet technique de traverser le temps, l'éditeur a le devoir d'adapter l'objet aux nouvelles technologies. La réédition est le prolongement du travail de l'éditeur d'origine.



BINY TABLE



English • Biny Table lamp is like an extra terrestrial creature in the world of lighting. Some people liken it to a robot. Others to a cartoon character. Others again to some radically efficient minimalist object. Designed in 1957 it remains resolutely modern. To make reading easier, Biny incorporated "blinds" that can be used to direct the light on to the reading surface. For a gentler but powerful light, this *developed re-edition** uses 2700K LED technology along with blinds that are controlled using a Flap Wheel.

**developed re-edition*: re-editing an object from the past is not a question of just looking in the mirror to see how things were done in the past. In order for a technical object to stand the test of time, the contemporary manufacturer has to adapt the object to the latest technologies. Re-editing became a prolongation of the work of the original editor.

Deutsch • Die Tischleuchte von Jacques Biny ist beinahe ein Außerirdischer in der Mondlandschaft (pardon !) in dem Leuchtenuniversum. Einige evokieren einen Roboter, manche eine Comicfigur und andere ein minimalistisches vollkommen effizientes Objekt. Entworfen im Jahre 1957 ist die Leuchte noch heute von großer Modernität. Für eine bessere Lesequalität hat Billy sie mit einer Art von Ventilatorenblättern ausgestattet, die den entsprechenden Lesebereich optimal erhellt. Für eine warme und erstaunlich gute Beleuchtung verfügt diese *weiterentwickelte Neuauflage** über eine integrierte LED Technologie mit 2700K. Die Ventilatorenblätter sind verstellbar.

**weiterentwickelte Neuauflage* : Die Neuauflage ist nicht ein Blick in den Rückspiegel. Um einem technischen Objekt die Reise durch die Zeit zu ermöglichen, muss der Verleger das Objekt der neuen Technologie anpassen. Die Neuauflage ist somit die Verlängerung der Arbeit des Erstverlegers.



BINY TABLE SW WH-BL-WH



BINY TABLE SW BL-WH
BINY TABLE SW WH-BL-WH
BINY TABLE SW BL-BL



BINY TABLE

Technique

FEATURES

- Dimensions (LxDxH in mm)
325 x 185 x 325
- Orientable flaps - Amplitude 50°
- Flaps wheel
- Materials: Steel, Aluminium

FINISHES (BOX-FLAP)

- BL-BL
 - WH-BL-WH (Foot-Box-Flap)
 - BL-WH
- BL: MAT BLACK / WH: MAT WHITE*

ELECTRIC INFORMATION

- Class II
- 230V-50Hz
- Detachable LED unit 10W-2700K
- Electric cord 2 m with detachable driver plug
- Lever switch on the lamp

CERTIFICATION

- CE

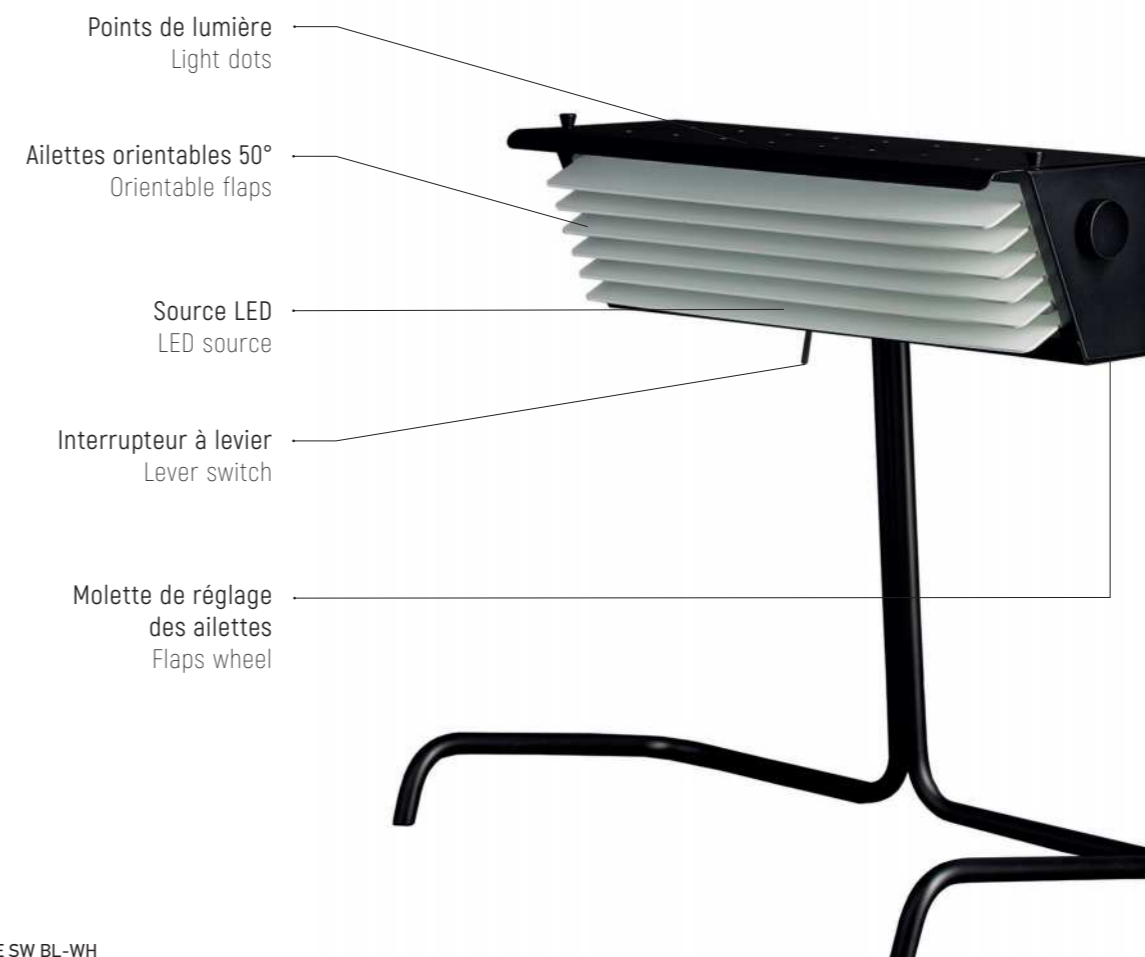
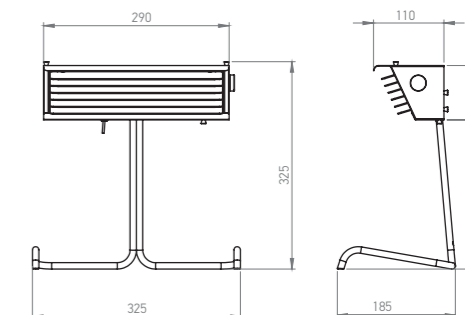

BINY TABLE SW BL-WH



BINY TABLE SW BL-WH
BINY TABLE SW WH-BL-WH
BINY TABLE SW BL-BL



BINY SPOT™

de Jacques Biny

Français • Tout droit sorti d'un monde de Jules Verne ou de Georges Méliès, le Biny Spot permet de diriger et concentrer le faisceau lumineux sur une zone bien précise. Le Spot Biny est composé d'une rotule originale qui permet une rotation à 330° et une inclinaison de 88°. Le Biny Spot est proposé en 2 finitions pour les bases : noir ou nickel et 3 finitions pour les hublots : noir, nickel ou laiton. Avec ou sans interrupteur, le Spot Biny est une *réédition développée* : avec LED intégré ou avec Ampoule LED gradable (non fournie).

English • With Biny Spot, Jacques Biny worked on how to concentrate a beam of light on a specific surface. The Biny Spot uses a unique rotating joint that can turn 330° around and 88° backwards and forwards. There are two finishes available for the base - black and nickel - and three for the covers - black, nickel and brass. Distributed either with or without its own switch, the Biny Spot is a *developed re-edition* and comes with either its own integrated LED or with a separate dimmable LED (not supplied).

Deutsch • Mit seinem Biny Strahler ist Jacques Biny bestrebt, den Lichtstrahl auf eine bestimmte Zone zu richten und zu konzentrieren. Der Strahler besteht aus einem originellem Kugelgelenk, das eine Drehung von 330° und eine Neigung von 88°. Den Strahler Biny gibt es in zweifacher Sockelausführung, schwarz oder nickel und in dreifacher Reflektorausführung, schwarz, nickel oder messing. Mit oder ohne Schalter ist der Strahler Biny eine weiterentwickelte Neuauflage : mit integrierter LED Technologie oder mit einer dimmbaren LED Glühbirne (nicht mitgeliefert).



BINY SPOT BL-BL



BINY SPOT BL-NK



BINY SPOT BL-GOL

BINY SPOT
Collection

| Without stick

BINY SPOT available with LED bulb (GU10 not supplied) or LED integrated
BINY SPOT also available with switch on LED integrated version

| With stick



BINY SPOT
BL-BL-NS



BINY SPOT
BL-NK-NS with SWITCH



BINY SPOT
BL-GOL-NS



BINY SPOT
BL-BL



BINY SPOT
BL-NK with SWITCH



BINY SPOT
BL-GOL



BINY SPOT
NK-BL-NS



BINY SPOT
NK-NK-NS with SWITCH



BINY SPOT
NK-GOL-NS



BINY SPOT
NK-BL



BINY SPOT
NK-NK with SWITCH



BINY SPOT
NK-GOL



BINY SPOT

Technique

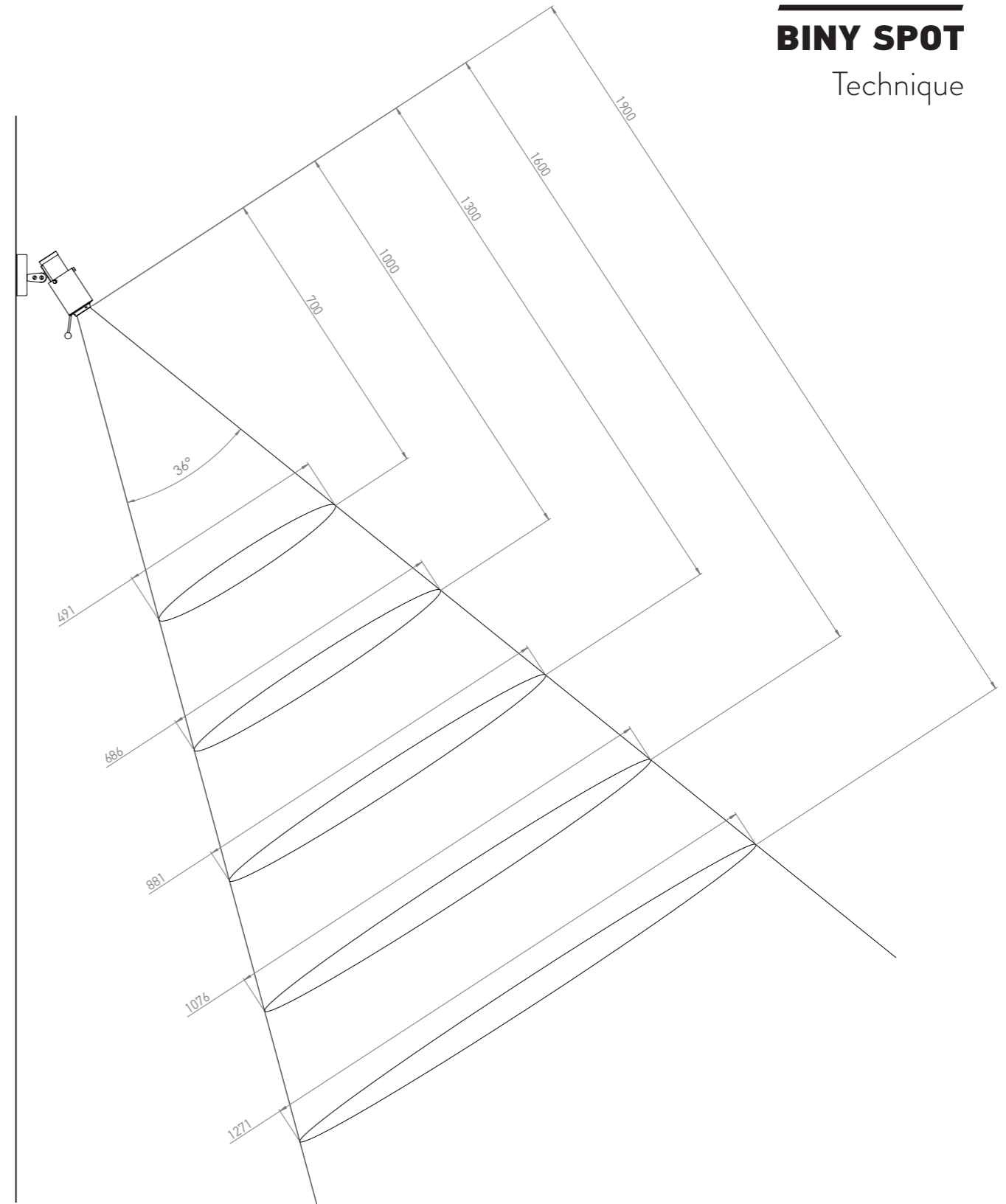

BINY SPOT

Technique



BASE with LED integrated



BASE with LED bulb (GU10 not supplied)

FEATURES

- Dimensions Ø 96 x 132-198
- Rotation axis
- Available with or without handle on tube
- Materials: Steel, Aluminium

FINISHES

BASE	TUBE
BL	BL
NK	NK
	GOL

BL: MAT BLACK
 NK: POLISHED NICKEL
 GOL: GOLD ANODIZED

ELECTRIC INFORMATIONS

- Class I
- 230V-50Hz
- 2 types of source:
 built-in LED or GU10 bulb
- Spot LED: 4,5W-2700K
- Lever switch available only on LED version

CERTIFICATION

- CE

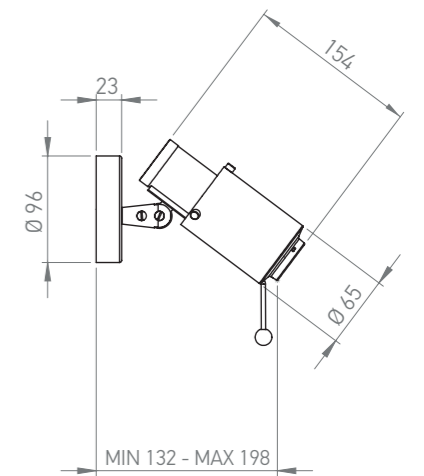

BINYBOX™

de Jacques Biny

Le confort d'une chambre et
le plaisir de lire dans un lit
dépendent de l'éclairage

A bedroom's atmosphere
and the pleasure of reading in bed
depend on the room's lighting

Das Wohlbefinden in einem
Raum und die Freude des Lesens
in einem Sessel sind bedingt
durch seine Beuchtung

LES BINY BOX RÉPONDENT À 3 EXIGENCES :

THE BINY BOXES HAVE THREE
KEY FEATURES:

DIE BINY BOX ERFÜLLT DIES MIT
DREI EIGENSCHAFTEN :

1

BIEN ÉCLAIRER
THEY LIGHT PERFECTLY
DIE AUSLEUCHTUNG IST PERFEKT

2

NE PAS ÉBLOUIR
THEY PREVENT GLARE
EINE BLENDUNG IST AUSGESCHLOSSEN

3

**CRÉER UN MINIMUM DE GÊNE VISUELLE
POUR CELUI QUI DÉSIRE DORMIR**
THEY DON'T ANNOY THE PERSON
WHO IS WISHING TO SLEEP
JEMAND DER NEBENAN SCHLÄFT
WIRD NICHT GESTÖRT

BINY BOX™

de Jacques Biny

Français • Lorsqu'elles ne sont pas utilisées en tête de lit, les appliques (Box 1, 2 et 3) sont également des appliques d'ambiance. Elles sont l'élément de base de l'éclairage d'une pièce. Avec les volets orientables, ces luminaires créent un jeu d'ombres et de lumière agréable et reposante. Les "Biny Box" contribuent à l'intimité et au confort d'une pièce, d'un couloir...

English • When not used as part of a bed-head, the Box 1, 2, 3 wall lamps can be employed to provide ambient lighting as the main components of a room's lighting. With their adjustable blinds throwing indirect light, the lamps combine a subtle play of light and shade with a warm and relaxing glow. Biny Boxes add to the intimacy and comfort of any room or corridor space.

Deutsch • Die Leuchten Box 1, 2, 3 lassen sich als Bettwandleuchten oder als gedämpfte Wandleuchten einsetzen. Sie sind das Grundelement der Raumbelichtung. Dank ihrer schwenkbaren Lamellen und der indirekten Beleuchtung kreieren diese Leuchten ein Spiel von Schatten und ein angenehmes und wohltuendes Licht. Die "Biny Box" tragen zu einer gemütlichen Atmosphäre und zum Komfort eines Raumes, eines Flures... bei.



BINY BOX 2 SW BL-BL



BINY BOX 1 BL-BL



BINY BOX 2 SW BL-WH



BINY BOX 3 SW WH-WH

BINY BOX 1

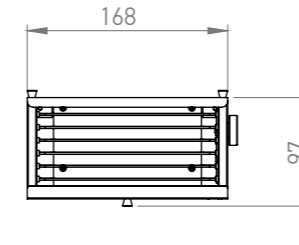

FEATURES

- Dimensions (LxDxH in mm) 168 x 102 x 85
- Orientable flaps - Amplitude 50°
- Flaps wheel
- Materials: Steel, Aluminium

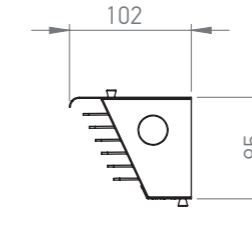

FINISHES (BOX-FLAP)

- BL-BL
- WH-WH
- BL-WH
- BL: MAT BLACK / WH: MAT WHITE**

BINY BOX 1, 2 et 3

Collection & Technique

ELECTRIC INFORMATIONS

- Class I
- 230V-50Hz
- Detachable LED unit 6W-2700K

CERTIFICATION

- CE

BINY BOX 2

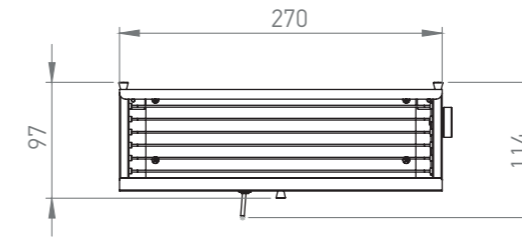

FEATURES

- Dimensions (LxDxH in mm) 270 x 102 x 85
- Orientable flaps - Amplitude 50°
- Flaps wheel
- Materials: Steel, Aluminium

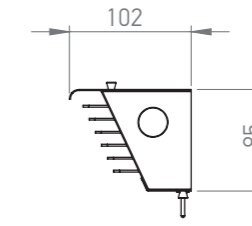

FINISHES (BOX-FLAP)

- BL-BL
- WH-WH
- BL-WH
- BL: MAT BLACK / WH: MAT WHITE**

ELECTRIC INFORMATIONS

- Class I
- 230V-50Hz
- Detachable LED unit 10W-2700K
- Option: Electric cord 2 m with switch and Schuko plug
- Option: Lever switch

CERTIFICATION

- CE

BINY BOX 3

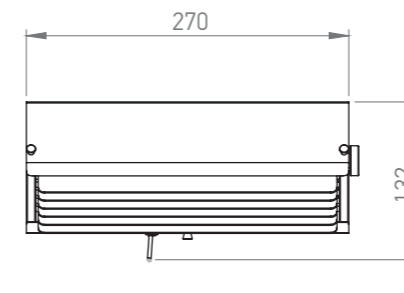

FEATURES

- Dimensions (LxDxH in mm) 270 x 128 x 110
- Orientable flaps - Amplitude 50°
- Direct + Indirect luminous flux
- Flaps wheel
- Materials: Steel, Aluminium

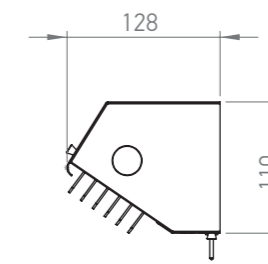

FINISHES (BOX-FLAP)

- BL-BL
- WH-WH
- BL-WH
- BL: MAT BLACK / WH: MAT WHITE**

ELECTRIC INFORMATIONS

- Class I
- 230V-50Hz
- Detachable LED unit 12W-2700K
- Option: Electric cord 2 m with switch and Schuko plug
- Option: Lever switch

CERTIFICATION

- CE

BINY BOX 3

Technique

Éclairage secondaire indirect
Indirect secondary lighting

Molette de réglage
des ailettes
Flaps wheel

Source LED
LED source
(movable)

Interrupteur à levier
Lever switch

Option : peut être aussi utilisé avec un
câble électrique (box 2 et box 3)
Option : could also be used with electric cable
(box 2 and box 3)

Ailettes
orientables 50°
Orientable flaps 50°



BINY BOX 3 SW WH-WH

BINY BEDSIDE™

de Jacques Biny

Français · L'applique de tête de lit très confortable qui évite toute fatigue visuelle.

Composée de :

- Spot LED intégré, permettant de lire sans déranger l'autre
- Plaque LED intégrée et amovible avec des volets orientables, permettant d'avoir un éclairage général de la chambre très doux
- D'un interrupteur 4 modes, permettant d'allumer soit l'une, soit l'autre, soit les 2 sources de lumière
- D'un port USB, permettant de recharger un smartphone, ou autre...

NB : ne fait pas le café.

English · The bed-head light very comfortable there is, specially designed to avoid eye fatigue. It includes:

- Integrated LED spotlight, allows one person to read without disturbing the other
- Integrated and movable LED plate with adjustable flaps, provides a gentle ambient light for the whole room
- Four-position switch allows for each light source to be controlled individually as well as together
- USB port for charging smartphone or other devices

Just one thing: it doesn't make coffee.

Deutsch · Höchstwahrscheinlich die komfortabelste Bettwandleuchte, die jede visuelle Müdigkeit vermeidet. Bestehend aus :

- Integrierter Led Strahler, der Lesen ohne Störung des Bettneighbarn erlaubt
- Integrierte, ersetzbare Ledplatte mit einstellbaren Lamellen, die eine generell gedämpfte Beleuchtung des Raumes hervorruft
- Schalter mit 4 Positionen, der entweder die eine oder die andere Lichtquelle oder beide ein-oder ausschaltet
- USB-Anschluss zur Aufladung eines Smartphones oder anderes

NB : kocht keinen Kaffee.



BINY BEDSIDE BL-WH LEFT



BINY BEDSIDE BL-WH LEFT

BINY BEDSIDE

Collection & Technique

FEATURES

- Dimensions (LxDxH in mm)
270 x 102 x 85
- Orientable flaps - Amplitude 50°
- Adjustable - Amplitude 100°
- Left and Right version available
- Flaps wheel
- Materials: Steel, Aluminium

FINISHES (BOX-FLAP)

- BL-BL
 - WH-WH
 - BL-WH
- BL: MAT BLACK / WH: MAT WHITE**

ELECTRIC INFORMATIONS

- Class I
- 230V-50Hz
- Detachable LED unit 6W
+ Spot LED 2W-2700K
- Pushbutton switch - 4 modes
- Option: Electric cord 2 m
with switch and Schuko plug

CERTIFICATION

- CE

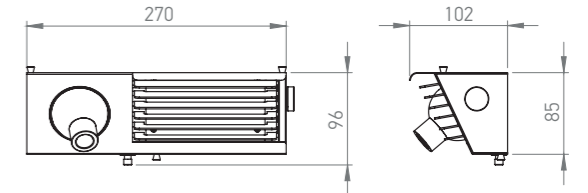

BINY BEDSIDE RIGHT

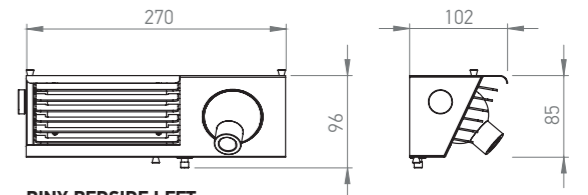

BINY BEDSIDE LEFT

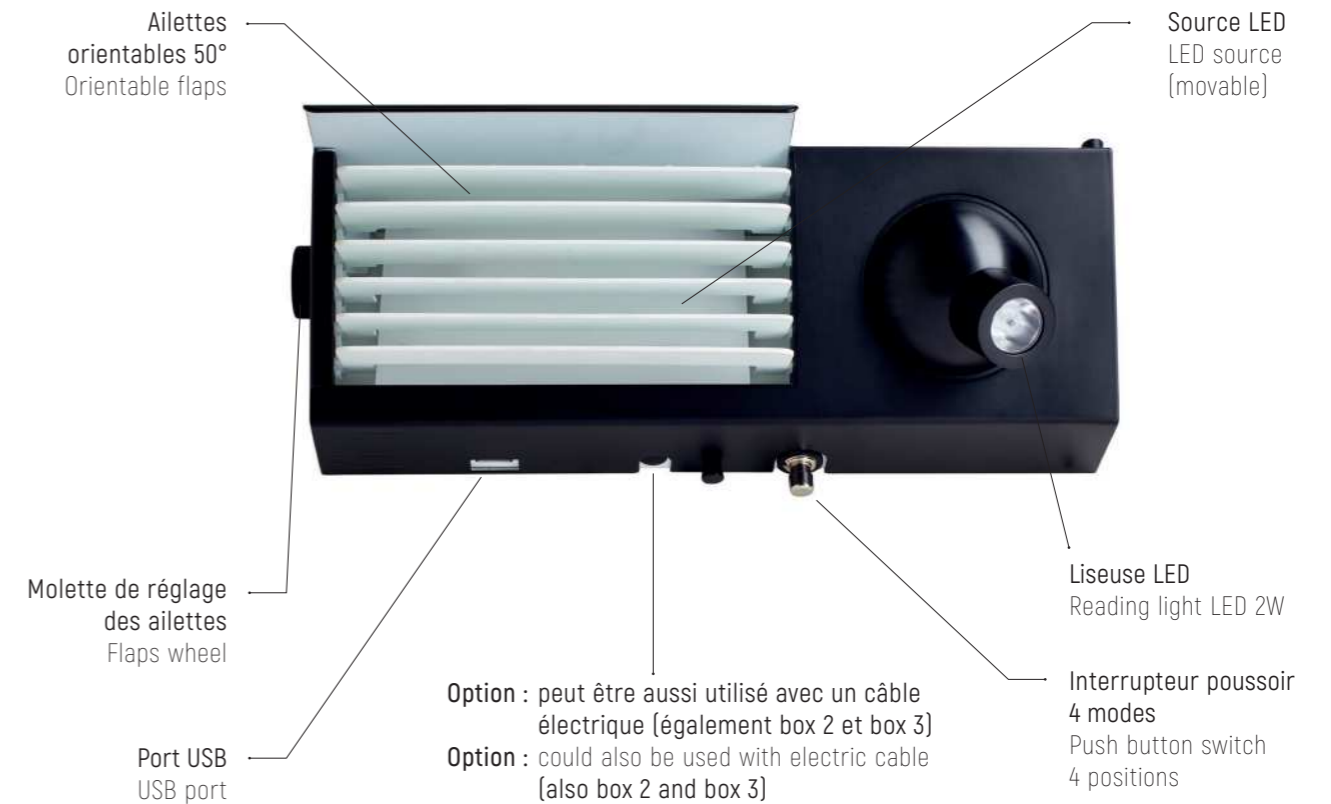

BINY BEDSIDE



BINY BEDSIDE BL-WH LEFT



BINY BEDSIDE BL-WH RIGHT



IN THE SUNTM

de Dominique
Perrault
et Gaëlle Lauriot-
Prévost

Français • Dans le cadre du réaménagement du Pavillon Dufour du Château de Versailles, Dominique Perrault et Gaëlle Lauriot-Prévost ont imaginé une collection de luminaires en hommage au Roi-Soleil. Cette collection "In The Sun" rayonne de ses ombres joyeuses et de ses lumières festives, dorées et argentées. De la pièce éclairée éclot une atmosphère toute particulière. En applique, plafonnier ou suspension, la magie s'empare du lieu.

English • As part of the renovation of the Pavillion Dufour at the Chateau de Versailles, Dominique Perrault and Gaëlle Lauriot-Prévost came up with a homage to the Sun King. The "In The Sun" collection radiates festive hues of gold and silver in conjunction with softly cast shadows. The result is a very special atmosphere in the rooms they are used to light. Whether wall-mounted, as a ceiling lamp or hanging, the result is consistently magical.

Deutsch • Im Rahmen der Renovierung des Pavillon Dufour im Schloss Versailles haben Dominique Perrault und Gaëlle Lauriot-Prévost eine Kollektion von Leuchten entwickelt, die eine Hommage an den Sonnenkönig darstellt. Der Anmut dieser Kollektion "In The Sun" erwächst aus den vergnügten Schatten und dem festliche gold-silberne Licht. Aus dem erleuchteten Raum entsteht eine ganz eigenwillige Atmosphäre. Ob als Wand-, Decken- oder Hängeleuchte, ein Zauber ermächtigt sich der Räumlichkeit.



ITS W 270 GOL-SIL



ITS 190 P GOL-GOL ; ITS 270 P GOL-GOL



ITS 190 P GOL-GOL ; ITS 270 P GOL-GOL ; ITS 380 P GOL-GOL

IN THE SUN CEILING LAMPS

Collection & Technique

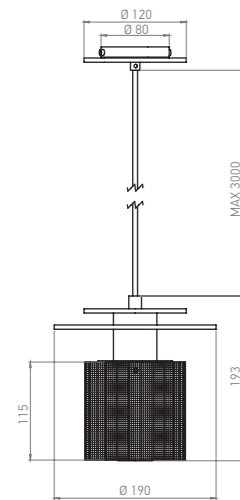

ITS 190

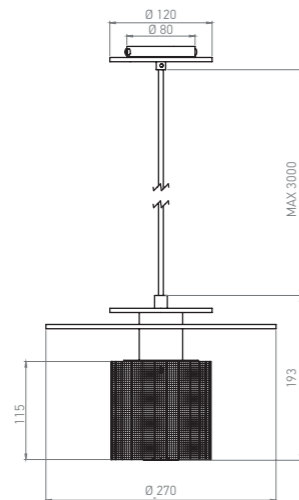

ITS 270

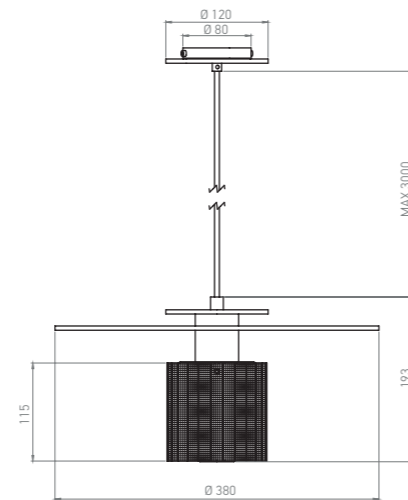

ITS 380

FEATURES

- 3 diameters (mm)
Ø 190 ; Ø 270 ; Ø 380
- Ceiling cup (mm) Ø 120
- Materials: Steel, Aluminium,
Brass mesh, Stainless steel mesh, Glass

FINISHES (BODY-MESH)

- GOL-GOL
- SIL-GOL
- SIL-SIL
- GOL-SIL
- SIL: SILVER**
(physical vapor deposition / PVD)
- GOL: GOLD**
(physical vapor deposition / PVD)

ELECTRIC INFORMATION

- Class I
- 230V-50Hz
- E27 ceramic lampholder
- Silicone cable 3 m
- Fast connectors WAGO 221

CERTIFICATION

- CE

IN THE SUN WALL LAMPS

Collection & Technique

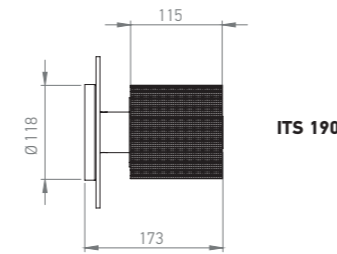

ITS 190

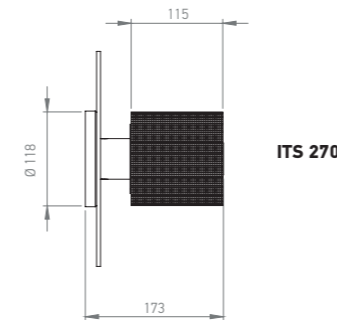
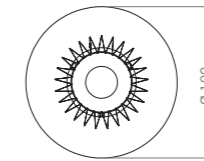

ITS 270

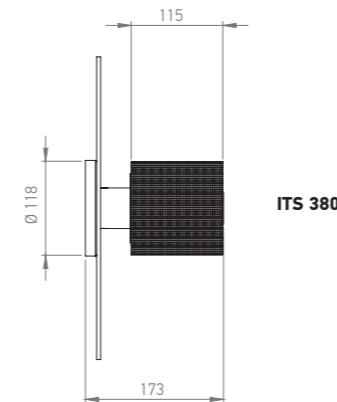
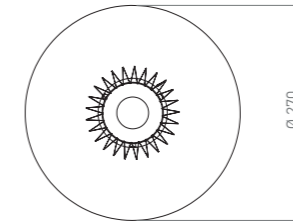

ITS 380

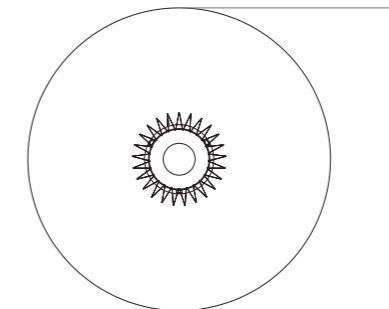

FEATURES

- 3 diameters (mm)
Ø 190 ; Ø 270 ; Ø 380
- Materials: Steel, Aluminium,
Brass mesh, Stainless steel mesh, Glass
- Option: Arrangement accessory
+ 25 mm ; + 50 mm

FINISHES (BODY-MESH)

- GOL-GOL
- SIL-GOL
- SIL-SIL
- GOL-SIL
- SIL: SILVER**
(physical vapor deposition / PVD)
- GOL: GOLD**
(physical vapor deposition / PVD)

ELECTRIC INFORMATION

- Class I
- 230V-50Hz
- E27 ceramic lampholder
- Fast connectors WAGO 221

CERTIFICATION

- CE

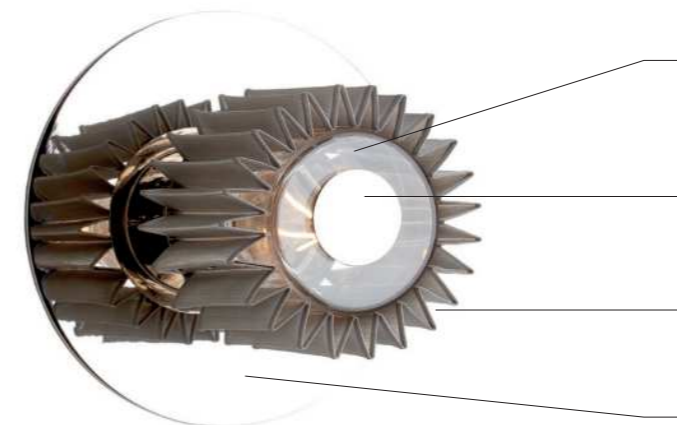

Verre
Glass

Rondelle acier (or ou nickel)
Silver or gold plated steel washer

Maille acier inoxydable (or ou argent)
Stainless steel mesh (gold or silver)

Disque aluminium (or ou nickel)
Silver or gold plated aluminum disc



ITS 190 W SIL-SIL ; ITS 270 W SIL-SIL (the wall lamp can be used as ceiling lamp)



COMPOSITION WITH: 2 x ITS 190 W GOL-GOL ; 2 x ITS 270 W GOL-GOL ; 1 x ITS 380 W GOL-GOL



ITS 190 W SIL-GOL ; ITS 380 W GOL-GOL ; ITS 270 W SIL-GOL



ITS 270 W GOL-GOL (the wall lamp can be used as ceiling lamp)

IN THE TUBE

de Dominique Perrault et Gaëlle Lauriot-Prévost

360°TM

Français • In the Tube 360° (ITT 360°). La source de lumière (LED sur profilé d'aluminium) émet à 360° sur 100 % de la longueur du tube. Ces ITT 360° peuvent être montés :

- 1/ avec des mailles argent ou or
- 2/ avec des volets, dits FLAPS permettant d'orienter la lumière, et pivotant à 360° (à l'horizontale ou à la verticale)
- 3/ le WING est conçu pour l'utilisation à l'horizontale

English • In the Tube 360° (ITT 360°). The light source (LED on aluminium profile) renders 360° on 100 % on the tube's length. ITT 360° could be used:

- 1/ without or with mesh silver or gold
- 2/ with FLAPS to orientate the light. Flaps pivotate 100° (horizontal and vertical)
- 3/ with WING for horizontal use

Deutsch • In der In the Tube 360° (ITT 360°) erstrahlt die Lichtquelle (LED auf einem Aluminiumprofil) rundum auf 360° und auf 100 % der Länge des Rohres.

Diese ITT 360° können montiert werden :

- 1/ mit einer gold - oder silberfarbigen Masche
- 2/ mit 360° schwenkbaren Klappen, benannt FLAP, welche es ermöglichen, das Licht auszurichten
- 3/ die WNG ist konzipiert und geplant für die horizontale Benutzung



ITT 360-400 SILVER

IN THE TUBE 360°

Technique

Joint Silicone (IP 64)
Silicon joint (IP 64)

Bouchon Silicone
Silicon cover



Visserie inox
Stainless steel screws

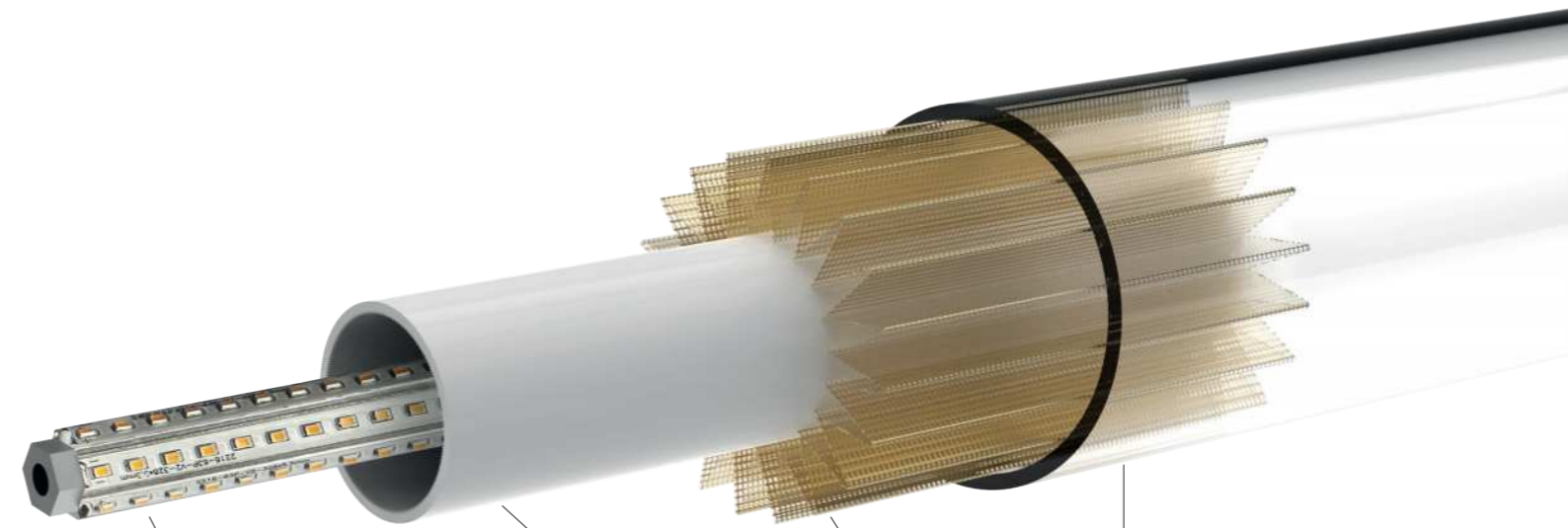

Réglettes LED 2700K
LED stripes 2700K

Tube en verre
Glass tube (option polycarbonate)

Maille or ou argent
Gold mesh or silver steel

Diffuseur
Diffuser

IN THE TUBE 360° with MESH or without

Collection & Technique

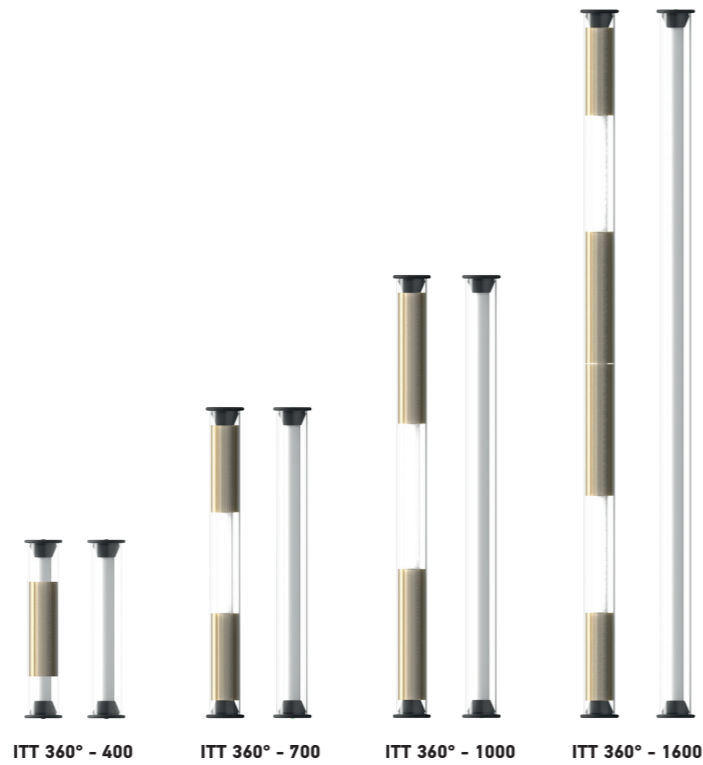
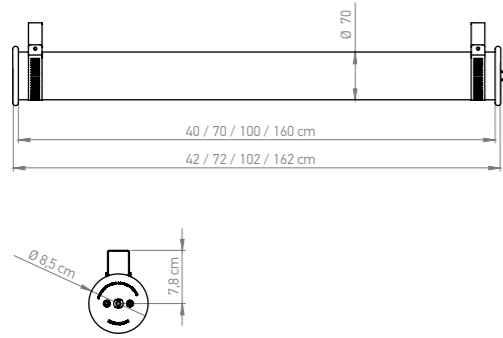

ITT 360° - 400 ITT 360° - 700 ITT 360° - 1000 ITT 360° - 1600

ITT 360° - 400

FEATURES

- Dimensions (LxDxH in cm)
42 x 8,5 x 8,5
- Glass tube diameter 7 cm
- Materials: Glass, Silicone, Inox
(Polycarbonate tube on request)
- Light on 360°
- IP 64
- Indoor/outdoor/bathroom
- Wall lamp or ceiling lamp

FINISHES

- NM: No mesh
- GOL: Gold mesh
- SIL: Silver mesh

ELECTRIC INFORMATION

- Class I
- External dimmable driver (TRIAC),
In: 230V, out: 350mA, 9W
- DALI on request
- LED 6W
- LED 2700K

CERTIFICATION

- CE

ITT 360° - 700

FEATURES

- Dimensions (LxDxH in cm)
72 x 8,5 x 8,5
- Glass tube diameter 7 cm
- Materials: Glass, Silicone, Inox
(Polycarbonate tube on request)
- Light on 360°
- IP 64
- Indoor/outdoor/bathroom
- Wall lamp or ceiling lamp

FINISHES

- NM: No mesh
- GOL: Gold mesh
- SIL: Silver mesh

ELECTRIC INFORMATION

- Class I
- External dimmable driver (TRIAC),
In: 230V, out: 350mA, 15W
- DALI on request
- LED 12W
- LED 2700K

CERTIFICATION

- CE

ITT 360° - 1000

FEATURES

- Dimensions (LxDxH in cm)
102 x 8,5 x 8,5
- Glass tube diameter 7 cm
- Materials: Glass, Silicone, Inox
(Polycarbonate tube on request)
- Light on 360°
- IP 64
- Indoor/outdoor/bathroom
- Wall lamp or ceiling lamp

FINISHES

- NM: No mesh
- GOL: Gold mesh
- SIL: Silver mesh

ELECTRIC INFORMATION

- Class I
- External dimmable driver (TRIAC),
In: 230V, out: 500mA, 27W
- DALI on request
- LED 18W
- LED 2700K

CERTIFICATION

- CE

ITT 360° - 1600

FEATURES

- Dimensions (LxDxH in cm)
162 x 8,5 x 8,5
- Glass tube diameter 7 cm
- Materials: Glass, Silicone, Inox
(Polycarbonate tube on request)
- Light on 360°
- IP 64
- Indoor/outdoor/bathroom
- Wall lamp or ceiling lamp

FINISHES

- NM: No mesh
- GOL: Gold mesh
- SIL: Silver mesh

ELECTRIC INFORMATION

- Class I
- External dimmable driver (TRIAC),
In: 230V, out: 900mA, 42W
- DALI on request
- LED 32W
- LED 2700K

CERTIFICATION

- CE



ITT 360° 1000 - BLACK FLAP 1000
WITH OR WITHOUT MESH

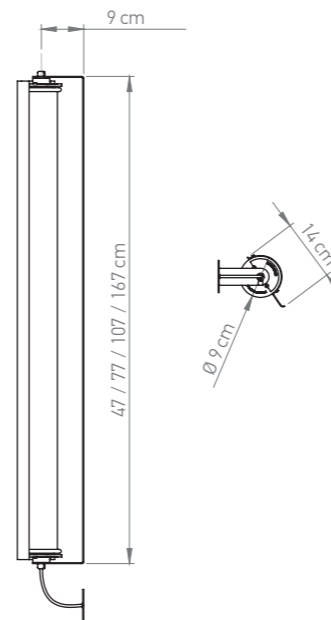

IN THE TUBE 360° with FLAP

Collection & Technique



ITT 360° - FLAP 400

FEATURES

- Accessory for ITT 360° - 400
- Dimensions (LxDxH in cm)
47 x 14 x 14
- Material: Stainless steel, Aluminium
- Rotating flap 360°
- Wall lamp, horizontal or vertical
- Indoor/outdoor/bathroom

FINISHES

- BL: Black flap, inside gold
- WH: White flap, inside gold

ITT 360° - FLAP 1000

FEATURES

- Accessory for ITT 360° - 1000
- Dimensions (LxDxH in cm)
107 x 14 x 14
- Material: Stainless steel, Aluminium
- Rotating flap 360°
- Wall lamp, horizontal or vertical
- Indoor/outdoor/bathroom

FINISHES

- BL: Black flap, inside gold
- WH: White flap, inside gold

ITT 360° - FLAP 700

FEATURES

- Accessory for ITT 360° - 700
- Dimensions (LxDxH in cm)
77 x 14 x 14
- Material: Stainless steel, Aluminium
- Rotating flap 360°
- Wall lamp, horizontal or vertical
- Indoor/outdoor/bathroom

FINISHES

- BL: Black flap, inside gold
- WH: White flap, inside gold

ITT 360° - FLAP 1600

FEATURES

- Accessory for ITT 360° - 1600
- Dimensions (LxDxH in cm)
167 x 14 x 14
- Material: Stainless steel, Aluminium
- Rotating flap 360°
- Wall lamp, horizontal or vertical
- Indoor/outdoor/bathroom

FINISHES

- BL: Black flap, inside gold
- WH: White flap, inside gold

IN THE TUBE 360° with WING

Collection & Technique

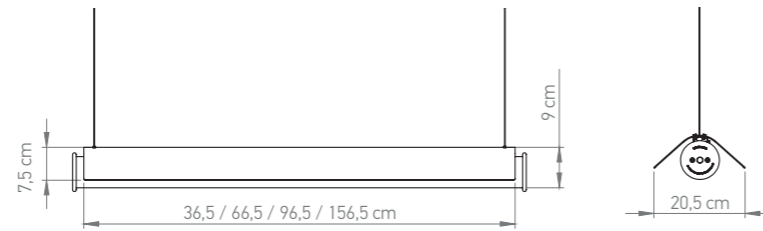

ITT 360° - BLACK WING 1000 - WITHOUT MESH



ITT 360° - WHITE WING 1000 - WITH MESH

ITT 360° - WING 400

FEATURES

- Accessory for ITT 360° - 400
- Dimensions (LxDxH in cm)
36,5 x 20,5 x 9
- Materials: Stainless steel,
Aluminium
- Indoor/outdoor/bathroom

FINISHES

- BL: Black reflector,
inside white + gold
- WH: White reflector,
inside white + gold

ITT 360° - WING 700

FEATURES

- Accessory for ITT 360° - 700
- Dimensions (LxDxH in cm)
66,5 x 20,5 x 9
- Materials: Stainless steel,
Aluminium
- Indoor/outdoor/bathroom

FINISHES

- BL: Black reflector,
inside white + gold
- WH: White reflector,
inside white + gold

ITT 360° - WING 1000

FEATURES

- Accessory for ITT 360° - 1000
- Dimensions (LxDxH in cm)
96,5 x 20,5 x 9
- Materials: Stainless steel,
Aluminium
- Indoor/outdoor/bathroom

FINISHES

- BL: Black reflector,
inside white + gold
- WH: White reflector,
inside white + gold

ITT 360° - WING 1600

FEATURES

- Accessory for ITT 360° - 1600
- Dimensions (LxDxH in cm)
156,5 x 20,5 x 9
- Materials: Stainless steel,
Aluminium
- Indoor/outdoor/bathroom

FINISHES

- BL: Black reflector,
inside white + gold
- WH: White reflector,
inside white + gold

IN THE TUBE 360° with FLAP

Collection & Technique

ITT 360° - TERMINAL BOX L

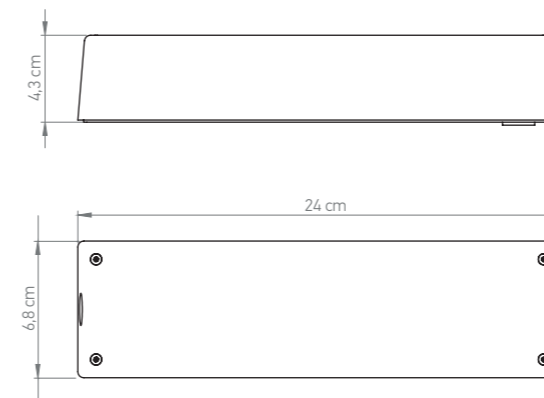

FEATURES

- Accessory for ITT 360° - 1000 and 1600
- Waterproof box for driver and wiring
- Dimensions (LxDxH in cm) 24 x 6,8 x 4,3
- Materials: Chromed aluminium
- Indoor/outdoor/bathroom
- IP 64

FINISHES

- Polished chromed

ITT 360° - TERMINAL BOX S

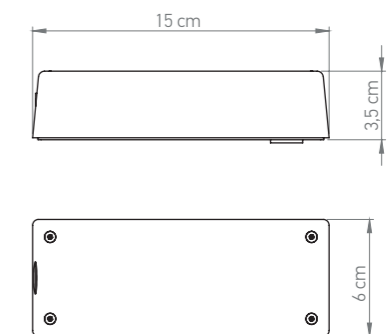

FEATURES

- Accessory for ITT 360° - 400 and 700
- Waterproof box for driver and wiring
- Dimensions (LxDxH in cm) 15 x 6 x 3,5
- Materials: Chromed aluminium
- Indoor/outdoor/bathroom
- IP 64

FINISHES

- Polished chromed



ITT 360-1600 WITH BLACK FLAP ; ITT 360-1000 WITH WHITE FLAP



ITT 360-1600 WITH BLACK FLAP ; ITT 360-1000 WITH WHITE FLAP



ITT 360-1600 GOLD ; ITT 360-400 SILVER



ITT 360-700 GOLD WITH BLACK WING

MANTIS

BS2 MINI™

Français • Bernard Schottlander s'est réellement inspiré de la mante religieuse pour créer cet objet intrigant et si gracieux. Son prototype était de petite taille. Nous avons décidé de l'éditer.

English • Bernard Schottlander was inspired by the praying mantis to create this intriguing and gracious wall lamp. His prototype was done in small size. We have decided to publish it.

Deutsch • Bernhard Schottländer liess sich von der Gottesanbeterin inspirieren, um dieses faszinierende und gleichzeitig graziöse wirkende Objekt zu erschaffen. Sein Entwurf war kleiner. Wir haben uns entschieden, es zu editieren.

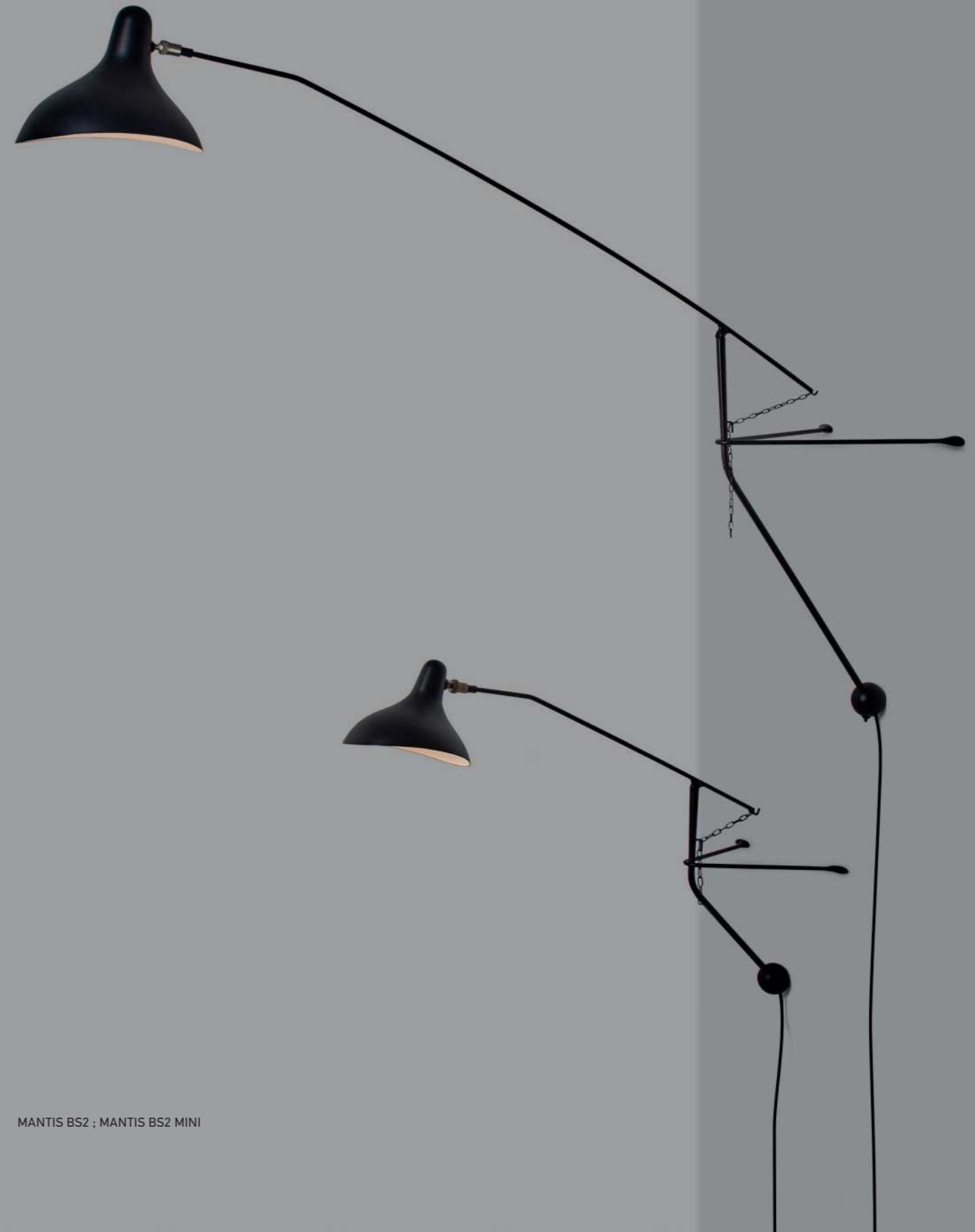

MANTIS BS2 ; MANTIS BS2 MINI

BS2 CLASSIC

Technique

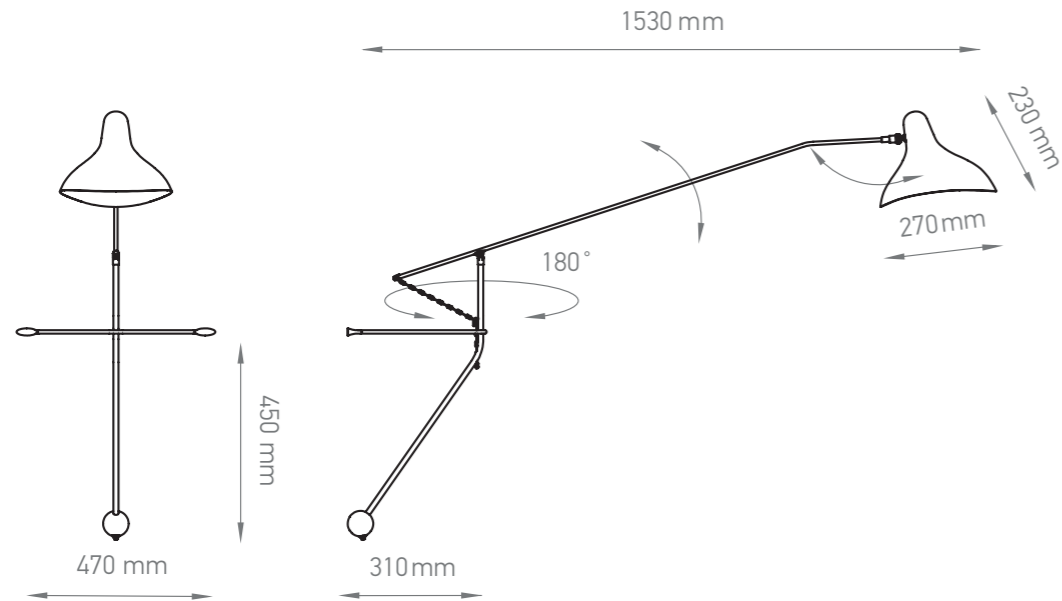

FEATURES

- Dimensions:
Wall to shade 1530 mm
Arms width 470 mm
Rotation 180°
- Materials: Steel, Aluminium

ELECTRIC INFORMATION

- Class II
- E14 – ESL11W
- Black electric wire
- Switch on the lamp

FINISHES

- BL
- **BL: BLACK**

CERTIFICATION

- CE

BS2 MINI

Technique

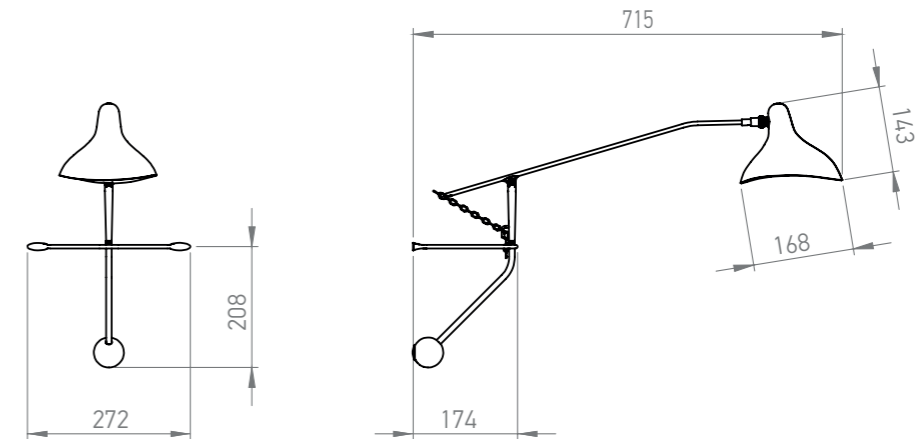

FEATURES

- Dimensions:
Wall to shade 715 mm
Arms width 272 mm
Rotation 180°
- Materials: Steel, Aluminium

ELECTRIC INFORMATION

- Class II
- LED 3W
- Black electric wire
- Switch on the cable

FINISHES

- BL
- **BL: BLACK**

CERTIFICATION

- CE



MANTIS BS2



MANTIS BS2 MINI

NOUVELLE COLLECTION

d'ÉRIC DE DORMAEL
by DCW éditions

Français · Admiratifs du travail d'Éric de Dormael, nous avons décidé de collaborer pour répondre à la demande d'oeuvres uniques dans le cadre de prescription haut de gamme.

Mais nous éditons également dès cette année, quelques objets uniques par leur caractère.

Ces "sculptures-lumière" caractérisées par leur légèreté, leur fluidité de forme et de transparence sont vouées aux jeux subtils de l'ombre et de la lumière. Les reflets, chatouillements, découpes et vibrations dansent sur les murs. Éric de Dormael fait naître des images, des impressions, des sensations.

English · Long-time admirers of the work of Éric de Dormael, we were always delighted to work together on some special upscale projects.

But this year, we are also going to edit some of his work that we consider so unique and very special indeed.

These "sculpture lights", characterised by their fluidity, their ethereality, their form and their transparency, are all about the subtle interplay of light and shadow.

The reflections, shimmers, patterns and vibrations they create dance off the walls. Éric de Dormael's creations bring forth images, they leave impressions and they provoke sensations.

Deutsch · Voller Bewunderung vor der Arbeit von Éric de Dormael und um einer Nachfrage nach hochwertigen Einzelstücken im Rahmen von Planungskonzeptionen nachzukommen, freuen wir uns über eine Zusammenarbeit mit ihm.

Darüber hinaus verlegen wir ab diesem Jahr einige seiner Objekte von außergewöhnlicher Eigenheit.

Diese Leuchtskulpturen ausgezeichnet durch ihre Leichtigkeit, ihre fließenden Formen sowie ihre Transparenz sind durch ein feinsinniges Spiel aus Licht und Schatten bestimmt.

Wiederspiegelungen, Schimmer, Gestalten und Vibrationen tanzen auf den Wänden. Éric de Dormael beschwört nicht nur Bilder, sondern auch Impressionen und Gefühle herauf.

LUNE & SATELLITE



BROCHE



TRON

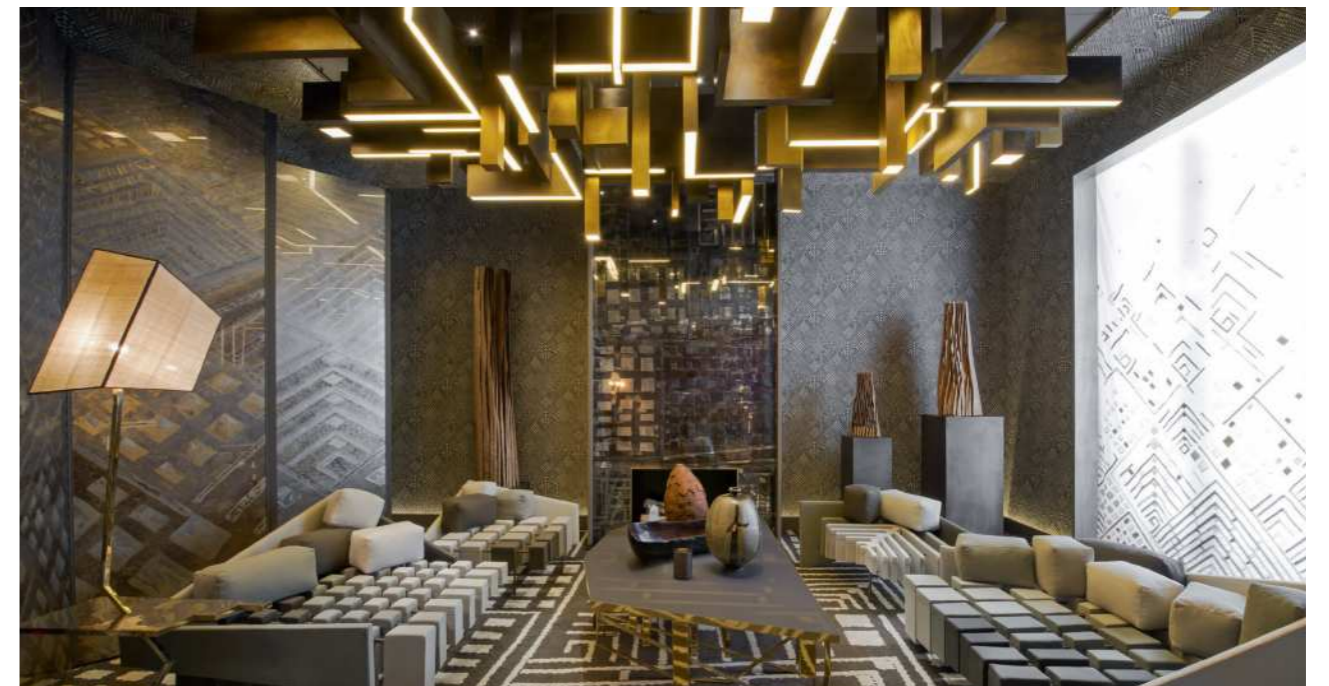

D'après un dessin et une scénographe de Jean-Louis Deniot / Drawing and scenography by Jean-Louis Deniot

BROCHE M

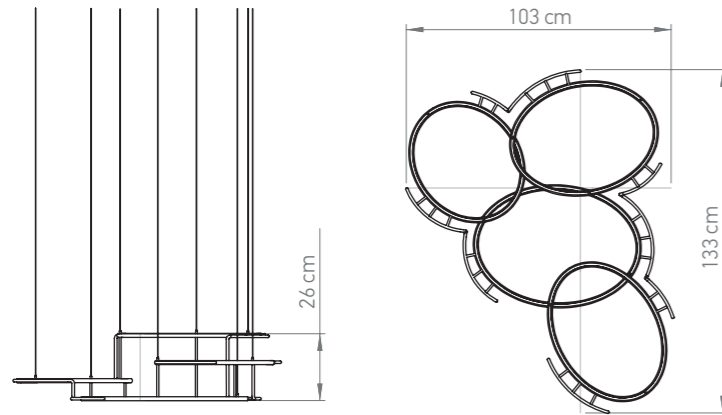

FEATURES

- Dimensions (LxDxH in cm) 133 x 103 x 26
- Materials: Natural brushed brass
- LED sources on top and down of each ring

FINISHES

- Natural brushed brass

ELECTRIC INFORMATION

- Class I
- Driver TRIAC, or DALI on request
- LED 100W, 2700K

CERTIFICATION

- CE

BROCHE L

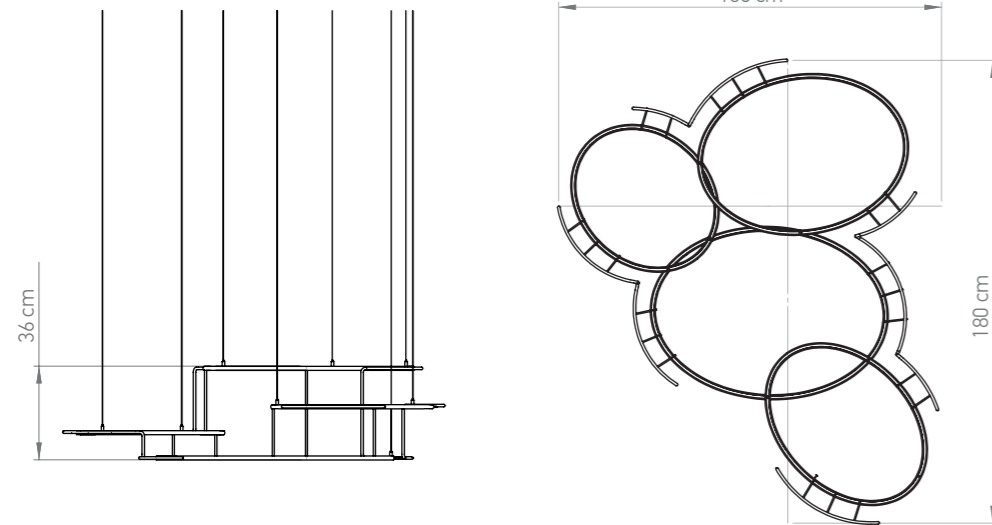

FEATURES

- Dimensions satellite (LxDxH in cm) 180 x 150 x 36
- Materials: Natural brushed brass
- LED sources on top and down of each ring

FINISHES

- Natural brushed brass

ELECTRIC INFORMATION

- Class I
- Driver TRIAC, or DALI on request
- LED 120W, 2700K

CERTIFICATION

- CE

NOUVELLE COLLECTION

Technique

LUNE

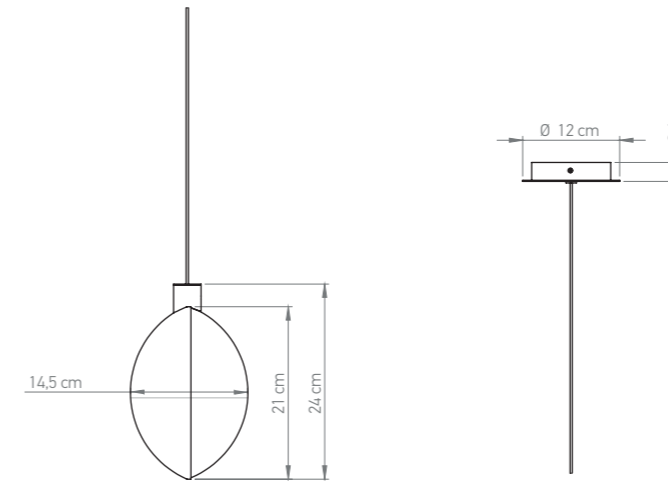

FEATURES

- Dimensions (LxDxH in cm) 24 x 21 x 14,5
- Diameter of Lunes: 21 cm
- Materials: Glass, natural brushed brass
- Delivered with ceiling cup

FINISHES

- Glass and natural brushed brass

ELECTRIC INFORMATION

- Class I
- Driver in the ceiling cup, In: 230V, out: 350mA, 4W
- Integrated LED 2W, 2700K, Driver TRIAC or DALI on request

CERTIFICATION

- CE

SATELLITE

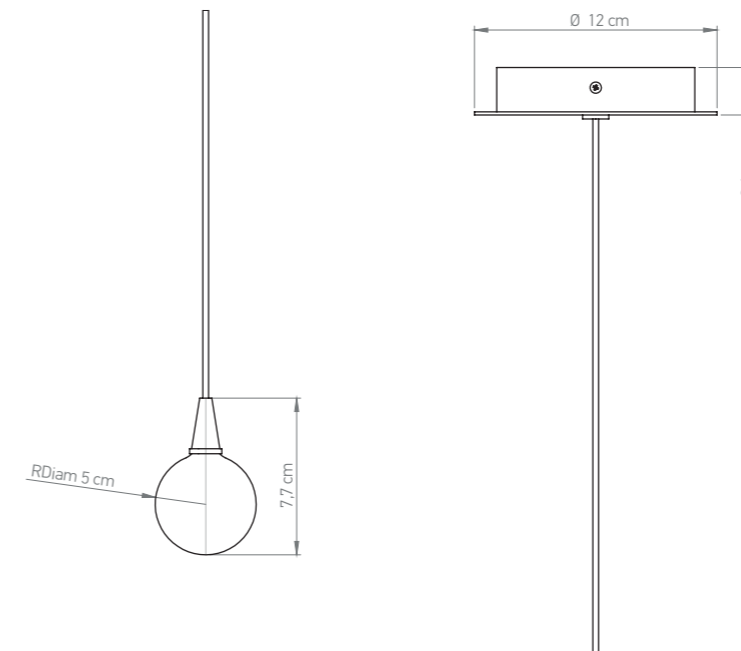

FEATURES

- Dimensions (LxDxH in cm) 7,7 x 5 x 5
- Diameter of Satellite: 5 cm
- Materials: Glass, natural brushed brass
- Delivered with ceiling cup

FINISHES

- Glass and natural brushed brass

ELECTRIC INFORMATION

- Class I
- Driver in the ceiling cup, In: 230V, out: 350mA, 4W
- Integrated LED 1W, 2700K, Driver TRIAC or DALI on request

CERTIFICATION

- CE

CONTACTS & REMERCIEMENTS

DCWéditions PARIS

71 rue de la Fontaine au Roi
75011 Paris – France
Tél. + 33 (0)1 40 21 37 60

-

SHOW ROOM

30-32 rue des Trois Bornes
75011 Paris – France

*Visit on appointment
Only for professionals 9am to 7pm
Closed during the week-end*

www.dcwe.fr

www.lampegras.fr
www.schottlander.fr
www.surpil.fr
www.herecomesthesun.fr
www.inthetube-lamps.com
www.isp-lamps.com
www.acrobatesdegras.fr

La Lampe GRAS™, Les ACROBATES
de GRAS™, Le MOBILIER de GRAS™,
HERE COMES THE SUN™,
MANTIS™, Bernard Schottlander™,
IN THE TUBE™, SURPIL™, ISP™, LUNE™,
BROCHE™, TRON™, IN THE TUBE
360°™, IN THE SUN™, BINY™
are trademarks of DCW Entreprises

MANAGEMENT

Philippe Cazer / p.cazer@dcwe.fr
Frédéric Winkler / f.winkler@dcwe.fr
Tel: + 33 1 40 21 37 60

SALES

sales@dcwe.fr
Tel: + 33 1 40 21 37 60

INTERNATIONAL:

Stanislas Dhellemmes /
stanislas@dcwe.fr
Tel: + 33 1 40 21 37 60
Mob: + 33 6 99 80 03 98

CONTRACT MANAGER:

Anne Mountels / anne@dcwe.fr
Tel: + 33 1 40 21 19 19
Mob: + 33 6 71 75 20 78

COMMERCIAL ADMINISTRATION

Véronique Barbier /
veronique@dcwe.fr
Tel: + 33 1 40 21 10 08

SPECIAL ACCOUNTS

Agnès Touzé / agnes@dcwe.fr
Tel: + 33 1 40 21 19 16

PRESS RELATIONS

Virginie Jouve /
relationspresse@virginiejouve.com

CATALOG

GRAPHIC DESIGN

Gaëlle Labérine /
gaelle@dcwe.fr
+ 33 1 43 57 59 03

ILLUSTRATIONS

Kay /
koybad@gmail.com
(pages 24, 36, 43)

PHOTOS

Ian Scigliuzzi /
www.ianscigliuzzi.com
+ 33 6 86 34 39 95

Marie-Pierre Morel /
mpm075@gmail.com
(pages 8, 10, 21, 37, 40)

MARKETING

Rodolphe Descheemaekere /
rodolphe@dcwe.fr
Tel: + 33 1 40 21 37 60

© All rights reserved to DCW éditions
Printed in February 2018
This catalog can not be sold

DCWéditions
PARIS

dcwe.fr

LES
COLLECTIONS
DU CATALOGUE
GÉNÉRAL

MbE

Miroir

—

ISP

de Ilia Sergeevich
Potemine

—

IN THE TUBE

de Dominique Perrault
et Gaëlle Lauriot-Prévost

—

MANTIS

de Bernard Schottlander

—

HERE COMES THE SUN

de Bertrand Balas

—

LES ACROBATES DE GRAS

—

LA LAMPE GRAS

de Bernard-Albin Gras

—

LAMPE GRAS XL OUTDOOR

—

LE MOBILIER DE GRAS

—

CHAISE SURPIL

de Julien-Henri Porché