

COLLECTION CATALOGUE

Infra-Structure, The Planning Magnet, The Tracking Magnet, The Tracking Power, Light Cut Mini, Moonline, Led Squad, In-Finity, Super Line, Super Flat, Light Bell, Light Shadow, The Black Line, Circle of Light, Led Curtain, Thin Line, The Fast Track, Fin LightLight®, Bon Jour, Light Sniper, Light Shooter, Light Supply, Johnny, Compass Box, Battery, Wan, Downlights, G-O, TheBlockOfLight, Giano, Box, Juncos, Wall Puncture, Uso, Uso Cove Lighting, Wall Piercing, Uso Boob, G-O, Soft Spot, Abajourd'hui, Teardrop, Us1, Optical Light, Usb Round & Profile, Lightlight® In System Profile, Us1 Out, Us1 900 Disk.

DEUTSCH / ENGLISH

FLOS
ARCHITECTURAL

FLOS ARCHITECTURAL LIGHTING

FLOS

NEW 16 - INFRA-STRUCTURE



46 - THE RUNNING MAGNET



NEW 82 - THE TRACKING MAGNET



112 - THE TRACKING POWER



136 - LIGHT CUT MINI



148 - MOONLINE



156 - LED SQUAD



164 - IN-FINITY



NEW 180 - SUPER LINE



192 - SUPER FLAT



206 - LIGHT BELL



NEW 216 - LIGHT SHADOW



232 - THE BLACK LINE



244 - CIRCLE OF LIGHT



256 - LED CURTAIN



266 - THIN LED



276 - FORT KNOX

For Knox Spot



NEW For Knox Wall LED



290 - WALL SYSTEM



NEW 298 - THE FAST TRACK



318 - FIND ME



330 - UT SPOT

UT Spot



UT Downlight



352 - SOLID PURE



364 - PURE

Pure Spot



Pure Downlight



384 - LIGHTLIGHT®

Lightlight® Wall



Lightlight® Pend/
Ceiling



Lightlight® Mono



400 - BON JOUR



NEW 410 - FREE SIXTY



420 - KAP

Easy Kap



Kap Downlight



Kap Surface/
Suspension



444 - TUBULAR BELLS



454 - LIGHT SNIPER



464 - LIGHT SHOOTER



474 - LIGHT SUPPLY



482 - JOHNNY



494 - COMPASS BOX

Compass Box
Surface



Compass Box
Recessed



508 - BATTERY

Battery Trim



Battery No Trim



Micro Battery



522 - WAN

Wan Spot



Wan Downlight



536 - DOWNLIGHTS

Light Soldier



Anthony Downlight



Decofix



Compass



Neutron



568 - G - O



578 - THEBLOCKOFLIGHT



586 - G I A N O



596 - BOX



SOFT - 3 D

614 - JUNCOS

1L
3L
6L
9L



SOFT - IN

624 - APPS



SOFT - LINEAR

630 - WALL RUPTURE



SOFT - IN

636 - USO

USO Kap 105
USO Kap 145
USO 332
USO 700
USO 800
USO 1000
USO 1400

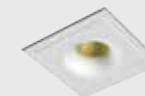

SOFT - IN

636 - USO COVE LIGHTING

900
1700
2200
2500
100 50
140 90



SOFT - 3 D

646 - WALL PIERCING

1x
2x
4x
2x Line



SOFT - OUT

654 - USO BOOB

600 1L
600 for
Modular Ceiling
600 2L
100 1L



SOFT - IN

660 - G - O IN



SOFT - 3 D

666 - SOFT SPUN

Halogen Small
Halogen Large
Fluorescent Small
Fluorescent Large
LED Small
LED Large



SOFT - 3D

674 - ABAJOURD'HUI

Small
Large



SOFT - IN

680 - TEARDROP

Small
Medium
Large



SOFT - 3D

686 - USL PLUTO

USL 100 Pluto
USL 200 Pluto



SOFT - IN

692 - ROUND LIGHT

Small
Medium
Large



SOFT - IN

692 - SQUARE LIGHT

Small
Large



SOFT - IN

692 - VERTICAL LIGHT

Small
Large



SOFT - IN

700 - USB ROUND

1L
1L W-W
2L
2L W-W



SOFT - IN

700 - USB SQUARE

1L
1L W-W
2L
2L W-W



SOFT - LINEAR

704 - SOFTPROFILE

Smooth Small
Smooth Large
Deco Starck Small
Deco Starck Large
Deco Wanders Small
Deco Wanders Large



SOFT - LINEAR

712 - KAPPROFILE



SOFT - LINEAR

718 - LIGHTLIGHT® IN SYSTEM PROFILE

Surface
Flushed
W-W



SOFT - OUT

722 - USL OUT

USL 6031
USL 6031 Recessed
USL 6060 for
Modular Ceiling



SOFT - OUT

726 - USL 900 DISK



INDEX BY PRODUCT
ALPHABETICAL ORDER

ARCHITECTURAL

549 – Anthony Downlight



288 – Fort Knox



163 – LED Squad



520 – Battery



419 – Free Sixty



215 – Light Bell



409 – Bon Jour



577 – G-O



147 – Light Cut Mini



605 – Box



595 – Giano



396 – Lightlight®



255 – Circle of Light



178 – In-finity



230 – Light Shadow



561 – Compass



44 – Infra-Structure



472 – Light Shooter



506 – Compass Box



492 – Johnny

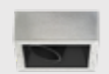

462 – Light Sniper



555 – Decofix



440 – Kap



543 – Light Soldier



328 – Find Me



265 – LED Curtain



480 – Light Supply



INDEX BY PRODUCT
ALPHABETICAL ORDER

ARCHITECTURAL

155 – Moonline



80 – The Running Magnet



567 – Neutron



110 – The Tracking Magnet



382 – Pure



134 – The Tracking Power



363 – Solid Pure



275 – Thin LED

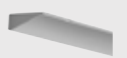

205 – Super Flat



453 – Tubular Bells



191 – Super Line



349 – UT Downlight



242 – The Black Line

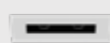

350 – UT Spot



585 – TheBlockofLight



296 – Wall System



317 – The Fast Track



535 – Wan



INDEX BY PRODUCT

ALPHABETICAL ORDER

SOFT ARCHITECTURE

679 – Abajourd'Hui



629 – Apps



665 – G-O In



623 – Juncos



717 – Kapprofile



721 – Lightlight® In System Profile



698 – Round Light



672 – Soft Spun



710 – Softprofile



698 – Square Light



685 – Teardrop

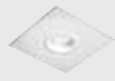

702 – USB Round



703 – USB Square



725 – USL OUT



731 – USL 900 Disk



691 – USL Pluto



643 – USO



659 – USO Boob



644 – USO Cove Lighting



699 – Vertical Light



653 – Wall Piercing



635 – Wall Rupture



Infra-Structure, The Running Magnet, The Tracking Magnet, The Tracking Power, Light Cut Mini, Moonline, Led Squad, In-Finity, Super Line, Super Flat, Light Bell, Light Shadow, The Black Line, Circle of Light, Led Curtain, Thin Led, Fort Knox, Wall System, The Fast Track, Find Me, UT Spot, Solid Pure, Pure, LightLight[®], Bon Jour, Free Sixty, Kap, Tubular Bells, Light Sniper, Light Shooter, Light Supply, Johnny, Compass Box, Battery, Wan, Downlights, G-O, TheBlockOfLight, Giano, Box.

ARCHITECTURAL LIGHTING

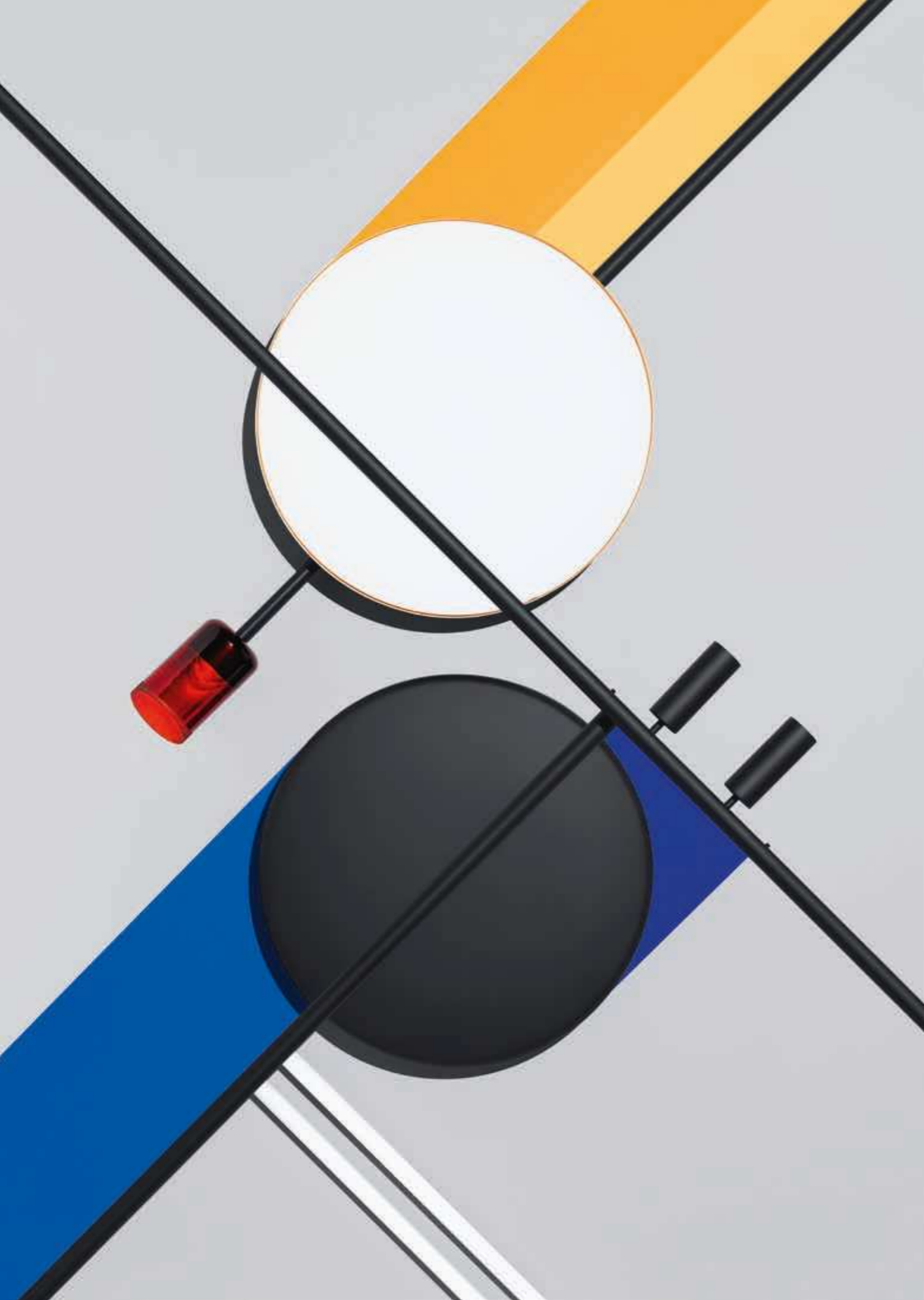

INFRA-STRUCTURE

Rohrförmige Struktur, die mit einer Vielzahl von Beleuchtungskörpern mit magnetischer Befestigung und mechanischer Sicherheitsverriegelung kompatibel ist. Einstellung und Steuerung mit Universalprotokollen und mit FLOS SMART CONTROL[®]-Anwendung.

INFRA- STRUCTURE

Tubular structure compatible with a wide range of light fixtures with magnetic fastening and mechanical safety locking. Regulation and control with universal protocols and using the FLOS SMART CONTROL[®] application.



DESIGNED BY VINCENT VAN DUYSSEN

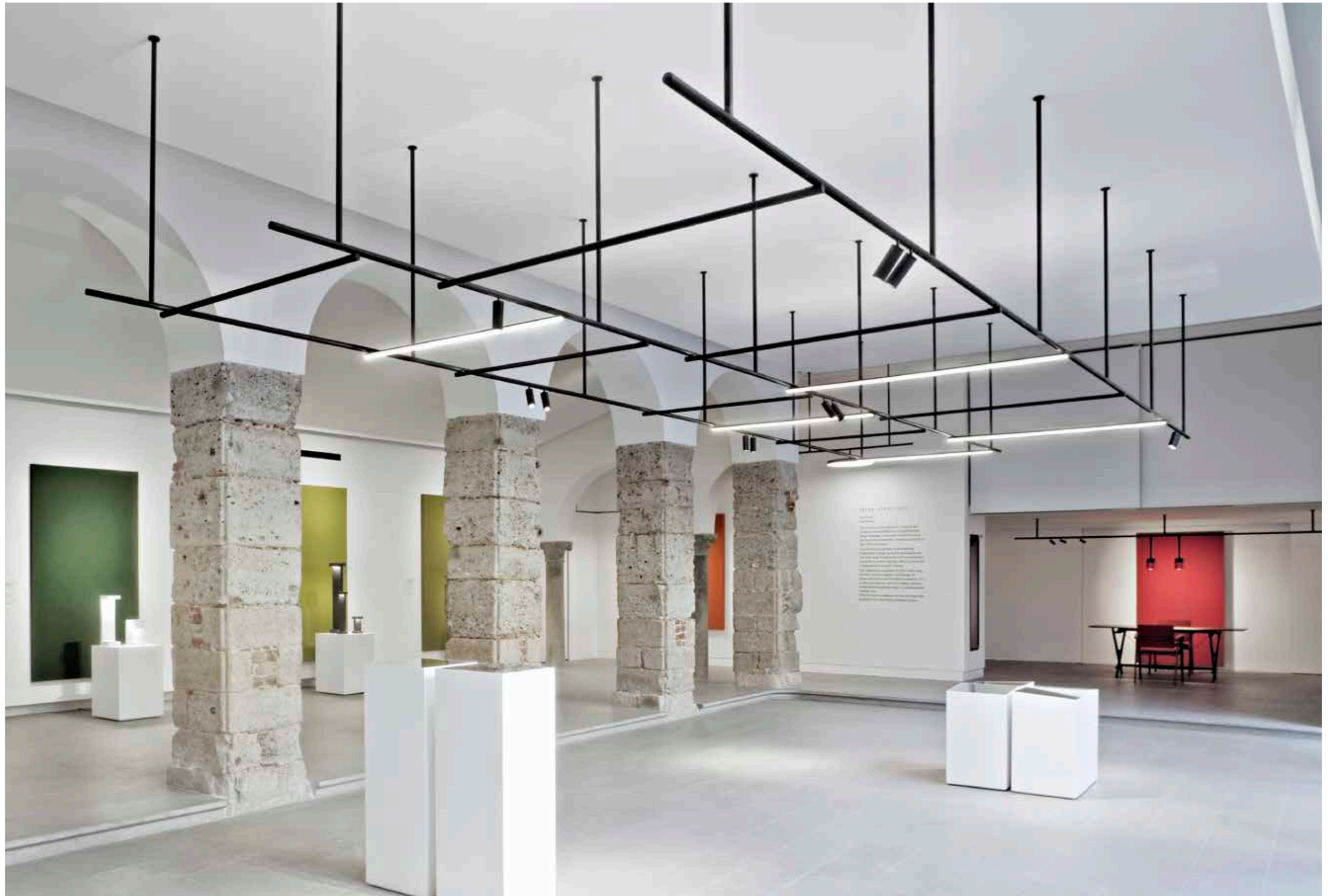



Das neue Symbol der Lichtstrukturen. Dank seines einzigartigen Designs und seiner Magnettechnik bietet Infra-Structure ausgezeichnete Möglichkeiten, die Lichtplanung im architektonischen Umfeld zu erweitern. Kompatibel mit allen Steuerungssystemen und FLOS SMART CONTROL®.

The new icon in lighting structures: thanks to its unique design and magnetic technology Infra-Structure offers a singular way to grow your lighting design in the architectural space. Compatible with all control systems and FLOS SMART CONTROL®.

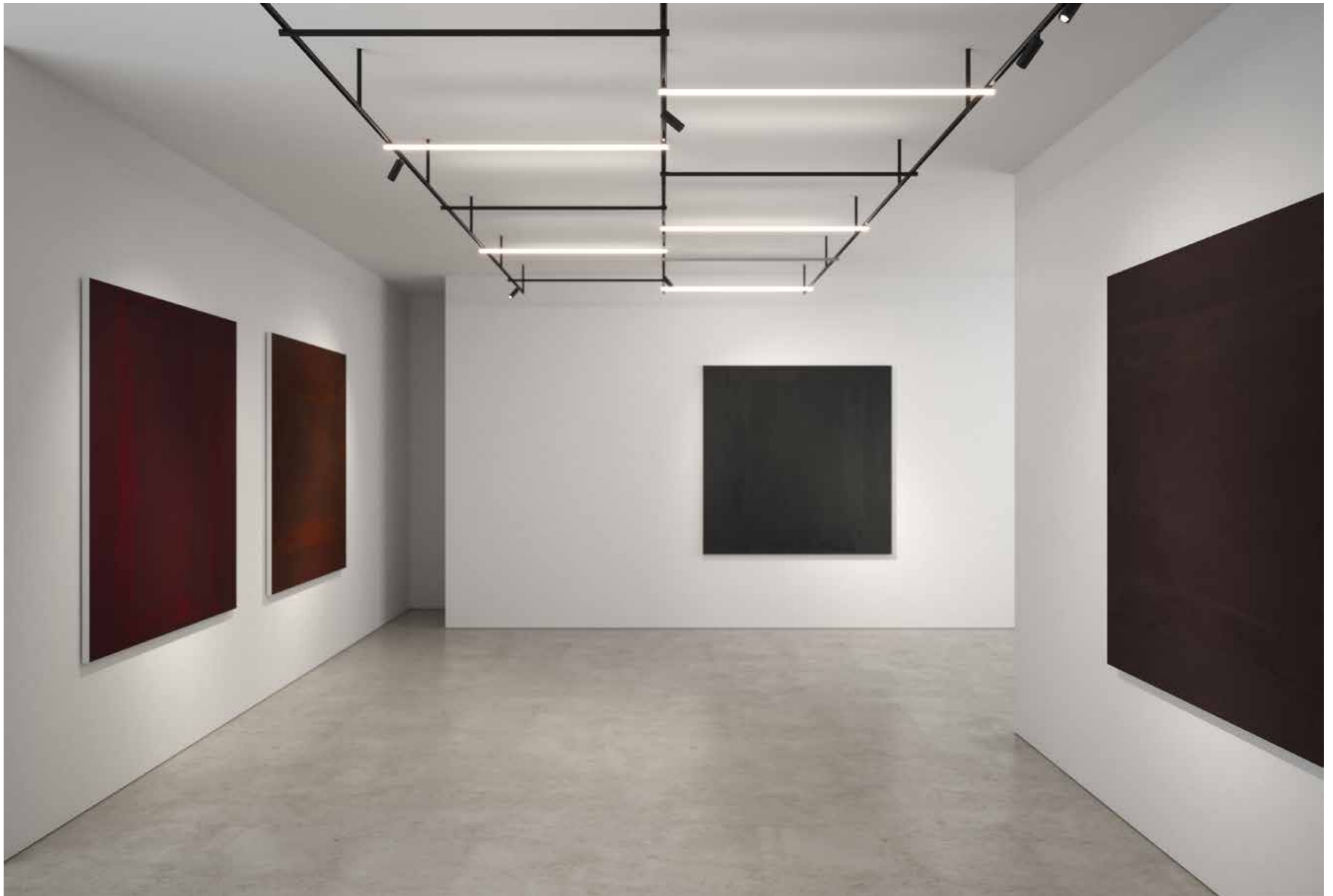

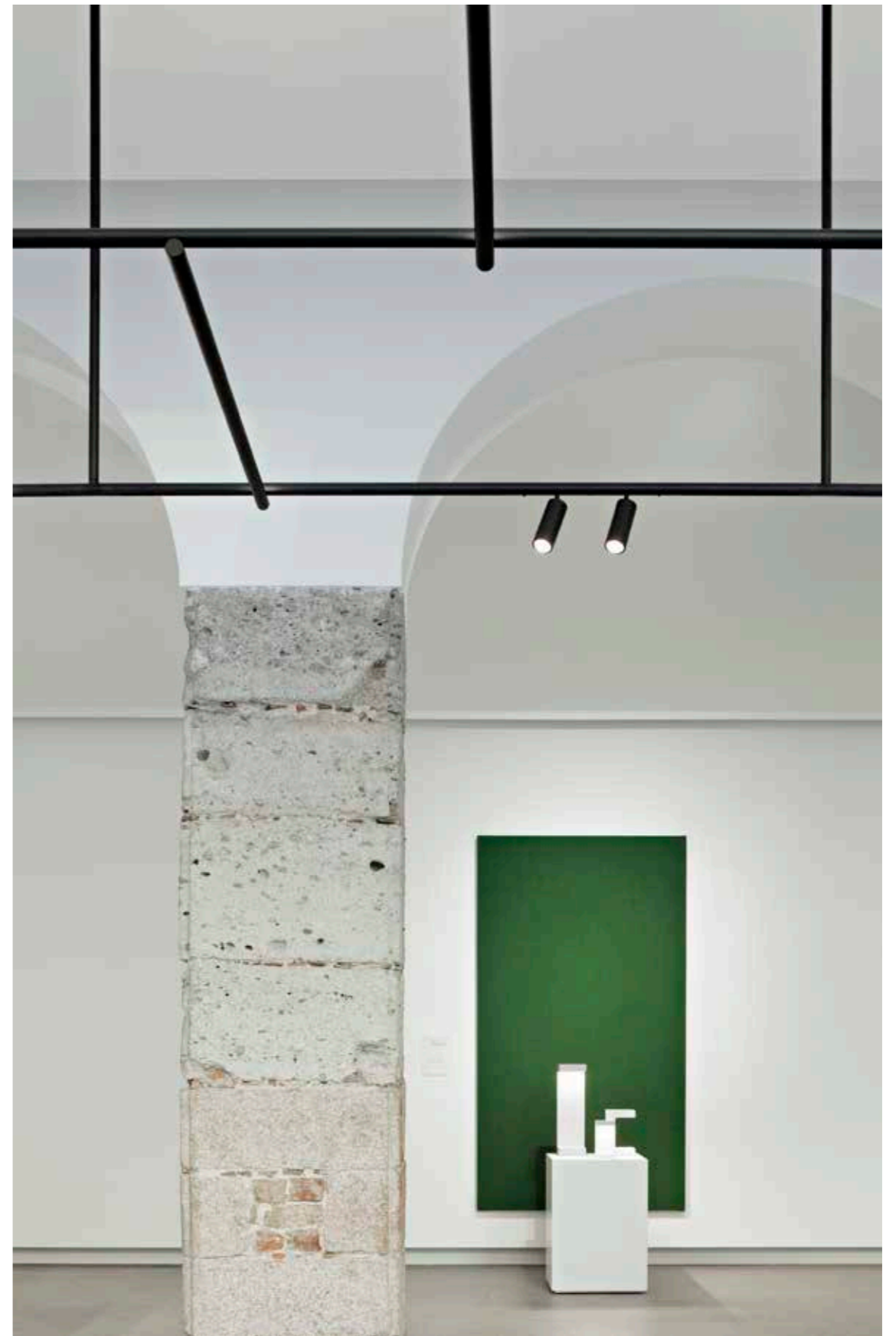
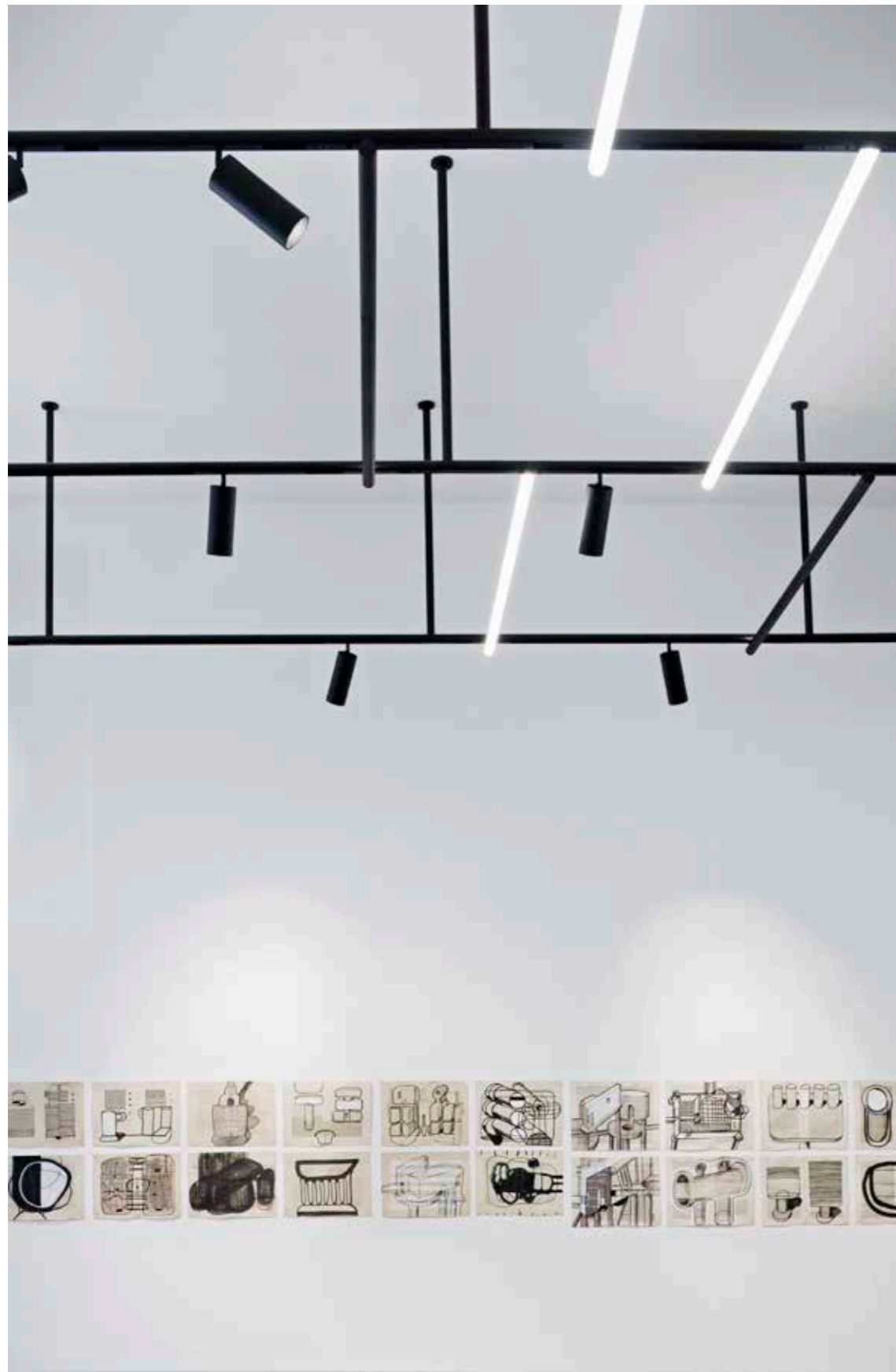



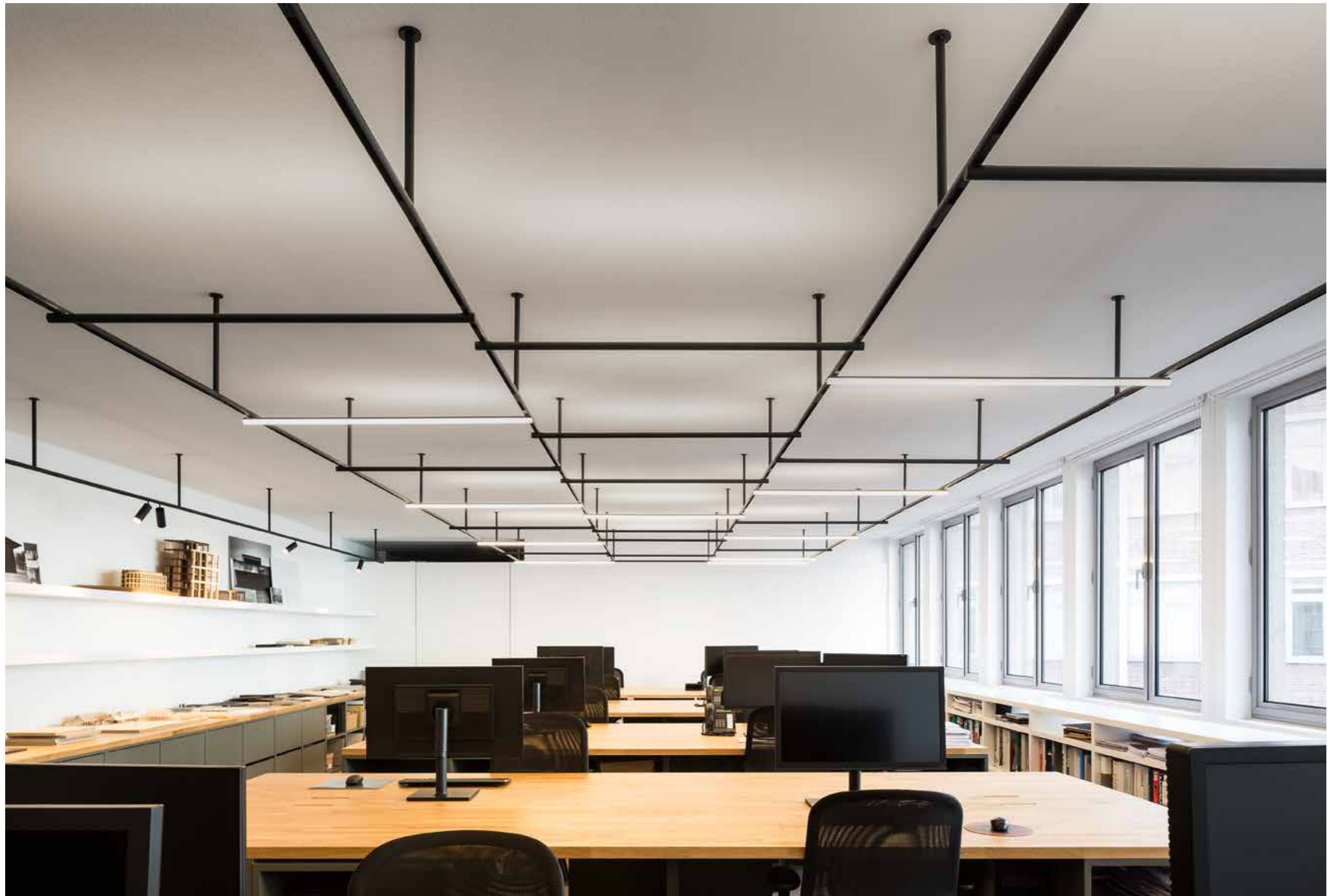

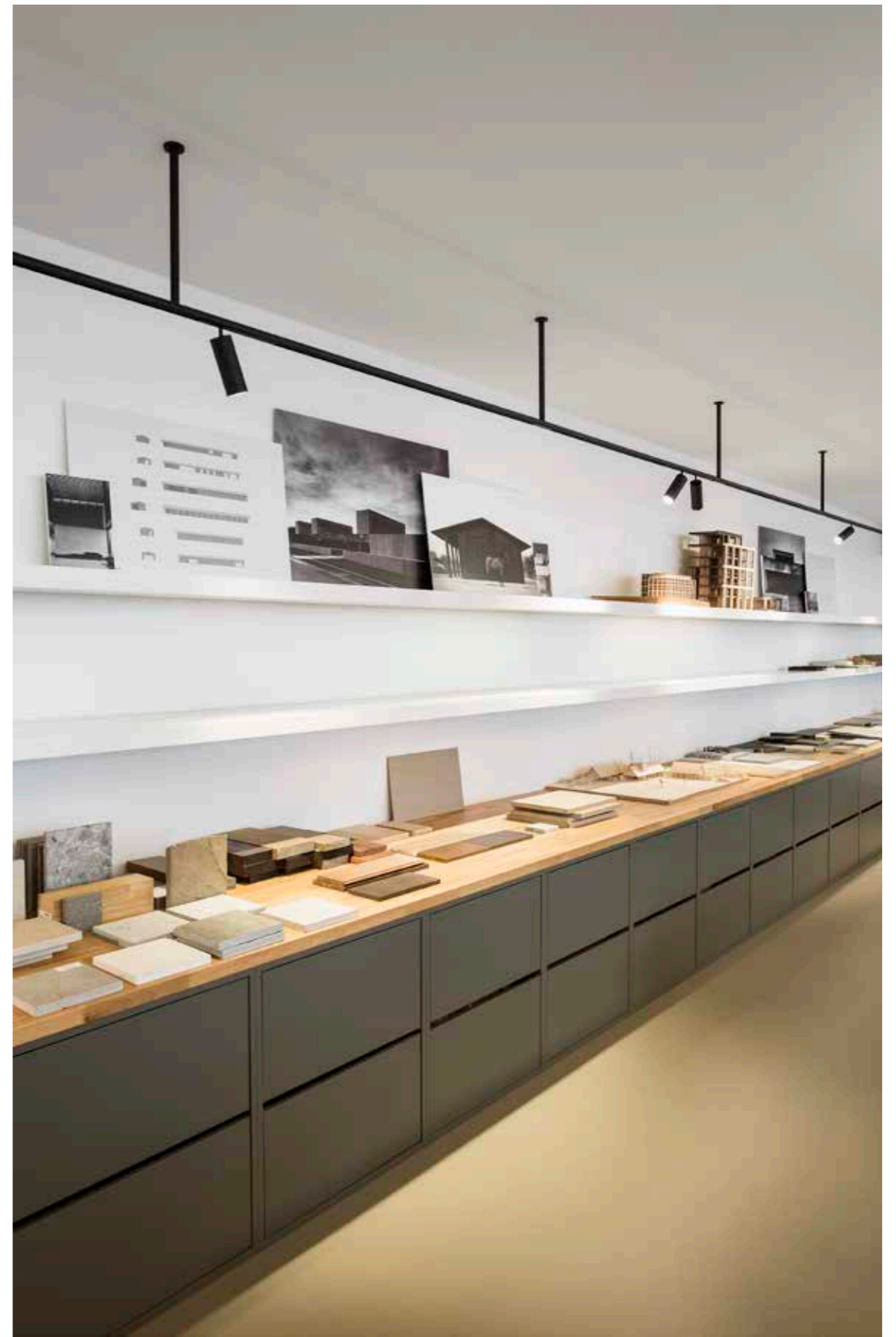



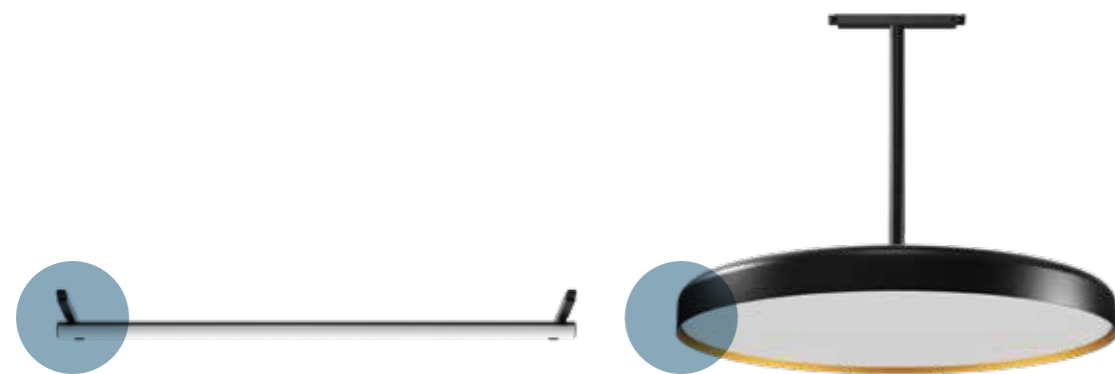

LIGHT TUBE / SUSPENSION PANEL 600

Leistungsstarker Opal-Diffusor für einheitliche Verteilung und erhöhten Sehkomfort.

Highly efficient opal diffuser, which allows for uniform distribution and guarantees high levels of visual comfort.



SUSPENSION GLASS
DOWNLIGHT 110

Dekorative Glocke in geblasenem Glas. Erhältlich mit transparenten, rauchigen und roten Oberflächen.

Decorative bell in blown glass. Available in transparent, fume and red finishes.





Verschiedene Kontrolloptionen, die jedes Bedürfnis decken können.

Different control options that can be adapted to any need.

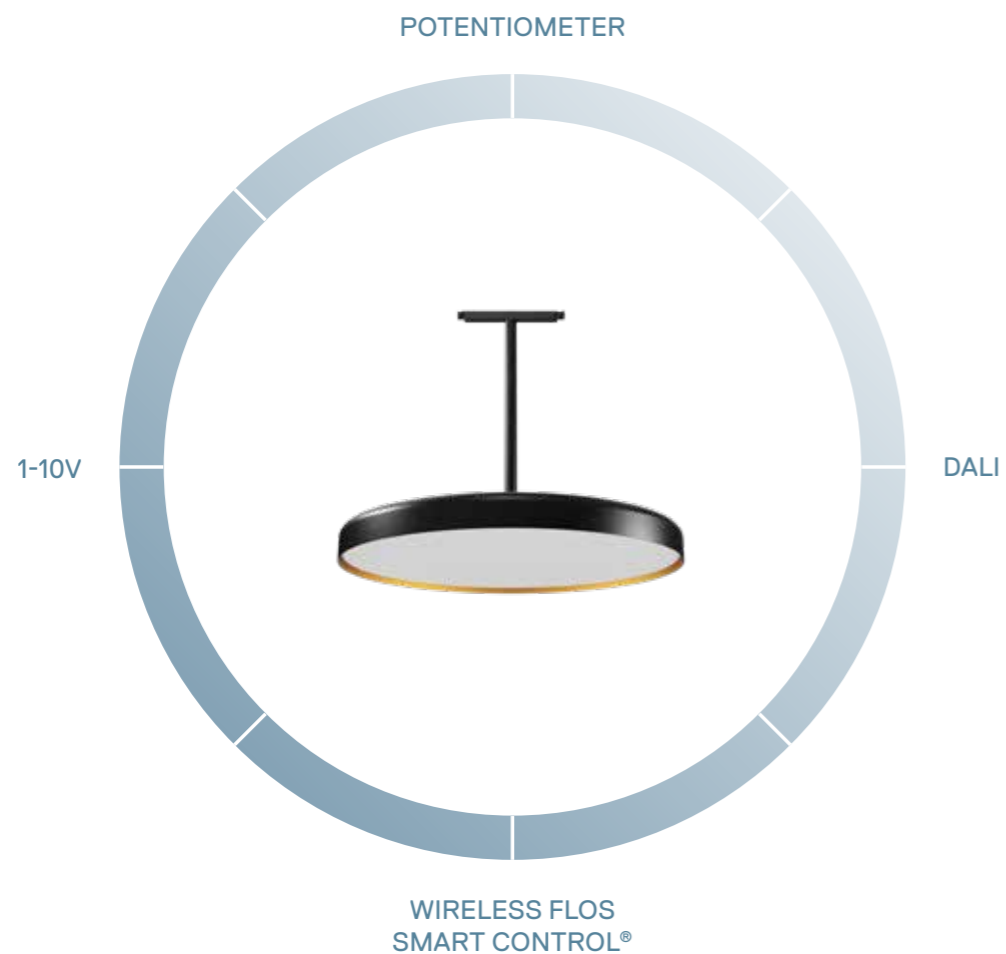

ON BOARD DIMMING: Jede Leuchte hat ihren eigenen integrierten Dimmer für direkte und individuelle Steuerung.

ON BOARD DIMMING: each luminaire has its own integrated dimmer for direct and individual control.

DALI: Individuelle Steuerung jeder Leuchte.

DALI: individual control of each luminaire.

1-10V: Broadcasting-Fernsteuerung (alle Leuchten in einer Gruppe gedimmt).

1-10V: broadcasting remote control (dimming of all the luminaires in a single group).

FLOS SMART CONTROL®: mit individueller Steuerung für jede Leuchte mit App auf Tablette oder Smartphone.

FLOS SMART CONTROL®: individual control of each luminaire directly through a tablet or smartphone application.

Die App FLOS SMART CONTROL® ermöglicht die Schaltung der Anlagenleuchten einzeln oder in Gruppen und so die Steuerung von Szenarien und Programmierung.

The FLOS SMART CONTROL® application allows you to control the system's luminaires individually or as a group, controlling scenes and programming.

Mit einer herkömmlichen Elektroinstallation und dem über Bluetooth angeschlossenen Gateway kann man stets genau die gewünschte Atmosphäre schaffen.

With a traditional electrical installation and the Gateway connected by Bluetooth, you obtain total control of the ambience.

Available for IOS and Android.

Für IOS und Android erhältlich.



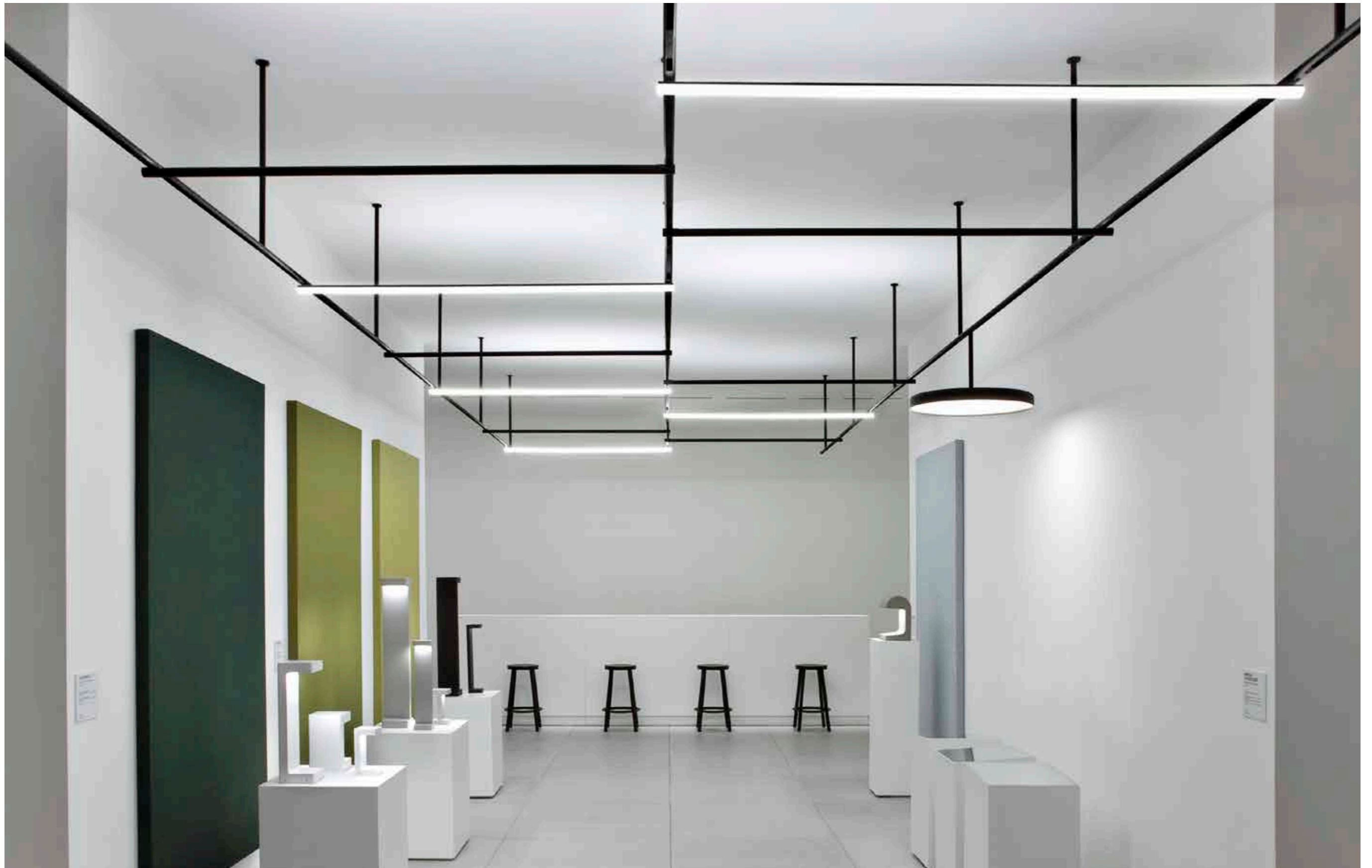



LIGHT MODULES

LIGHT TUBE
DIRECT - INDIRECT

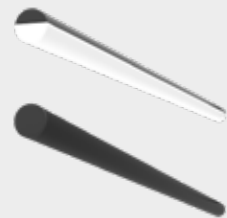

TOP LED
25W/m

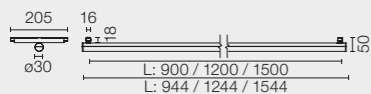

SPOT 50



POWER LED
3,5W

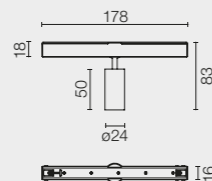

SPOT 90



POWER LED
8,5W

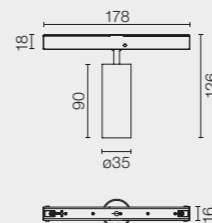

SPOT 120



POWER LED
12W

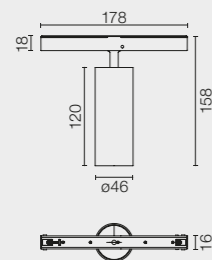

SPOT 120



LED ARRAY
12,5W

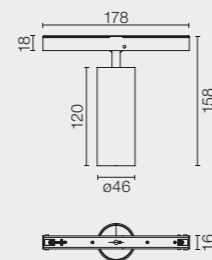

SPOT 150



LED ARRAY
22,5W

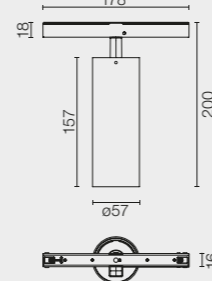

Spot

Medium

Flood

LIGHT MODULES

SUSPENSION
PANEL 600



TOP LED
40W

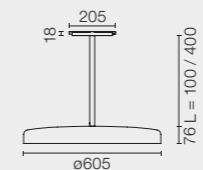

SUSPENSION
GLASS DOWNLIGHT 110

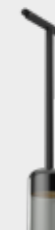

LED ARRAY
13,5W

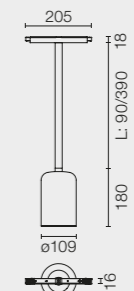

□ 40 Weiss
40 White ■ 14 Schwarz
14 Black



FLOS
SMART CONTROL





THE RUNNING MAGNET

Strukturprogramm als Einbau-, Anbau- oder Pendelvariante. Eine breite Palette an Beleuchtungskörpern kann mithilfe der magnetischen Befestigung darin untergebracht werden. Einstellung und Steuerung mit Universalprotokollen und mit FLOS SMART CONTROL®-Anwendung.

THE RUNNING MAGNET

Program of structures in recessed, surface and suspended versions. A wide range of light fixtures is housed inside it using magnetic fastening. Regulation and control with universal protocols and using the FLOS SMART CONTROL® application.

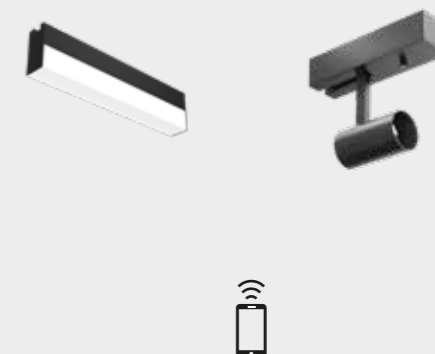

DESIGNED BY FLOS ARCHITECTURAL

Die Lösung für eine totale Fusion mit der Architektur in dem die Strahler so integriert sind, dass sie vollkommen unter der Oberfläche verschwinden. Seine magnetische Befestigung bietet eine vollkommen einfache Lichtplanung des Raums. Kompatibel mit allen bekannten Steuerungssystemen und FLOS SMART CONTROL®.

The solution for a total fusion with architecture, achieved thanks to the total integration of luminaries that can disappear inside surfaces. Its magnetic installation offers super easy way to design the light in space. Compatible with all main control systems and FLOS SMART CONTROL®.

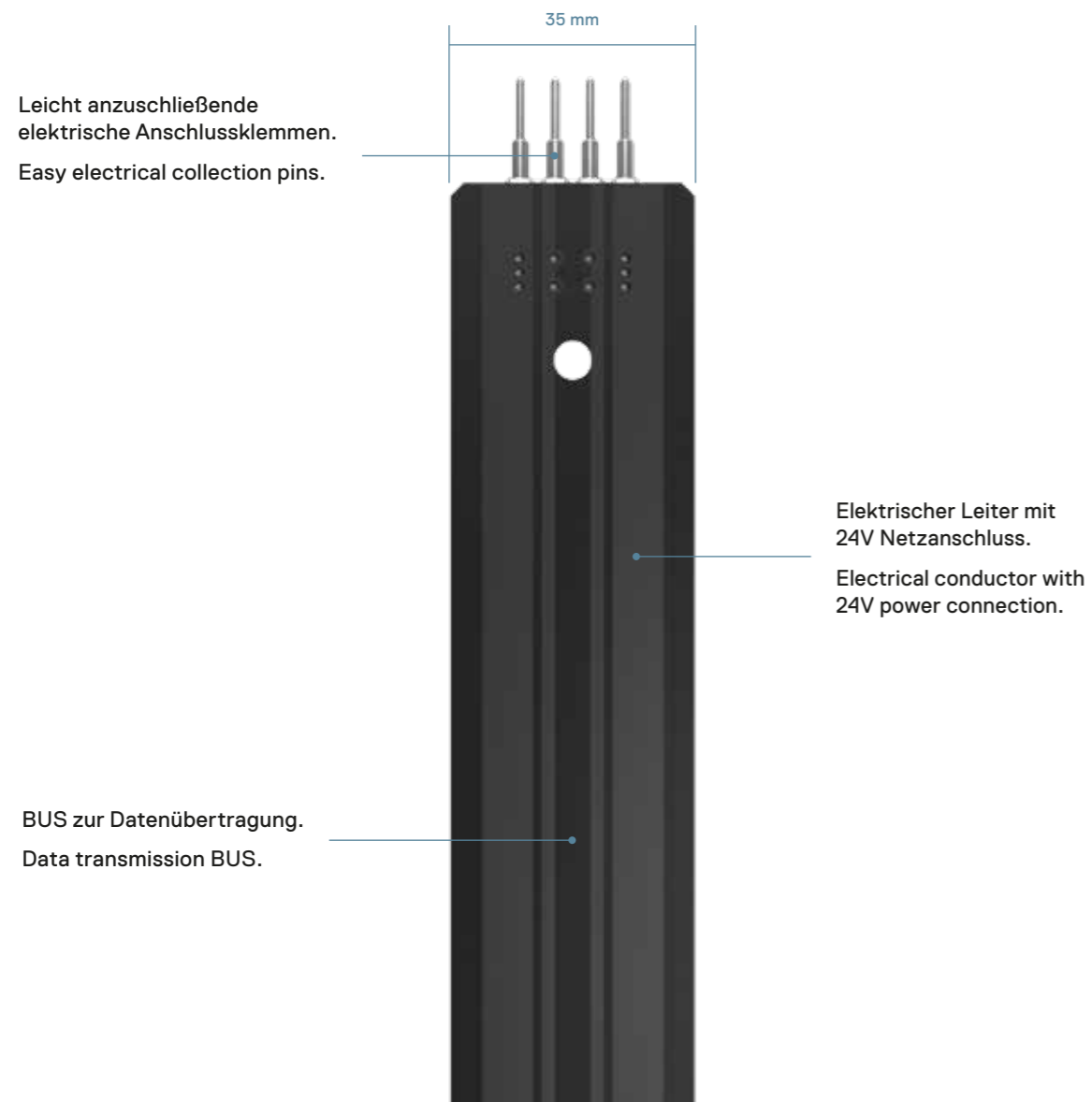







SPOT MODULE

Für maximale Flexibilität und Integration konzipierter Strahler, der sich als Deckenlicht profilbündig einsetzen oder mit einer 360°-Ausrichtung und 90°-Schwenkwinkel extern anbringen lässt.

Projector created for maximum flexibility and integration, as it can be fitted flat to the profile. Zenithally light or its extraction and orientation to 360 degrees and tilting to 90 degrees.

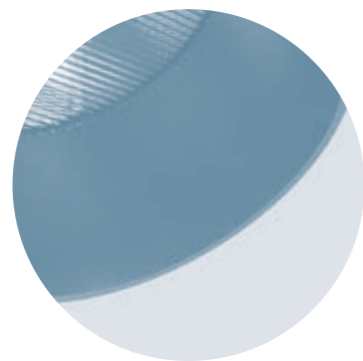

Abschirmender Außenzylinder.
Exterior shield cylinder

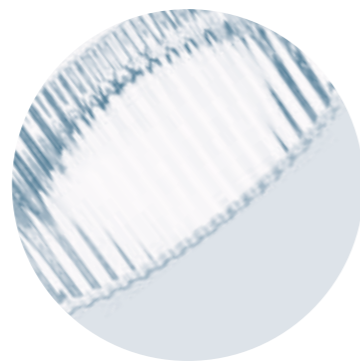

Elliptische Linse als Zubehör verfügbar.
Elliptical lens available as accessory.



SPOT 120

Hochleistungsstrahler mit Minimaldesign.
Power projector with minimal design.



ANTHONY SPOT

Anthony Spot von Designer Antonio Citterio - schlichte, elegante Form mit einem Hauch Avantgarde-Design, die sich von traditionellen Konzepten abhebt.

Anthony Spot designed by Antonio Citterio: a form with a touch of avant-garde design, simple yet elegant, which is distanced from traditional looks.

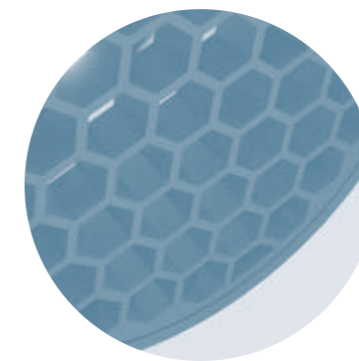

Für stets maximalen Sehkomfort ist für alle Strahler Schirmzubehör erhältlich.
Shielding accessories available in all projectors, to always offer maximum visual comfort.

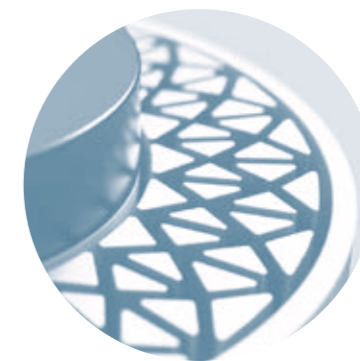

Innovative Wärmeableiter-Konstruktion.
Novel heat dissipater design.



LIGHT STRIPE

Magnetische Lichtleisten in verschiedenen Längen erhältlich. Diese können aneinandergereiht werden, wodurch sich der GAP-Effekt (Unterbrechung des Lichts an den Stoßstellen) - sogar in Ecken - verhindern lässt.

Der speziell entwickelte Opaldiffusor sorgt für eine effiziente, homogene architektonische Integration.

Magnetic light bar available in different lengths, which offers the possibility of joining and eliminating the gap effect, even in corners.

The specially developed opal diffuser guarantees both efficiency and homogeneity in architectural integration.

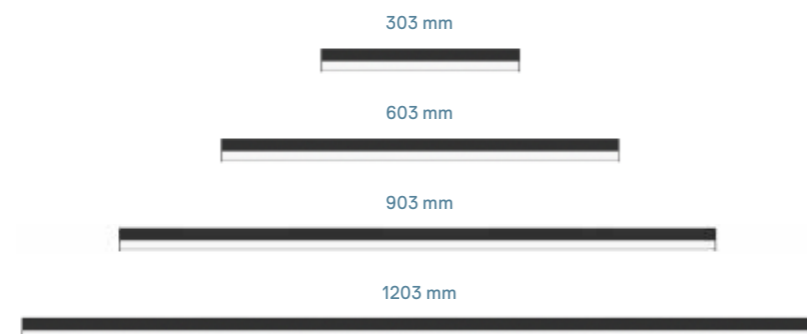

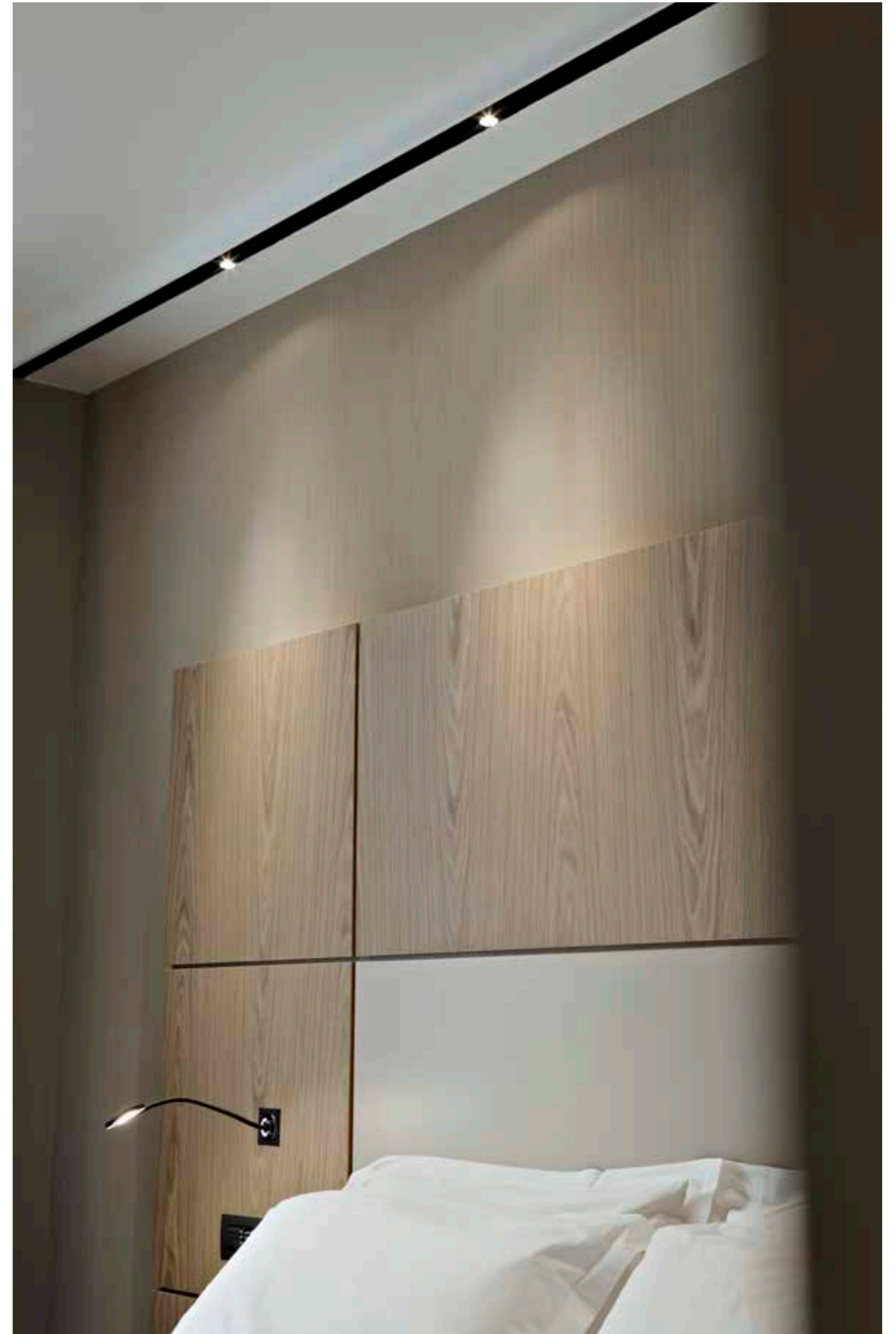

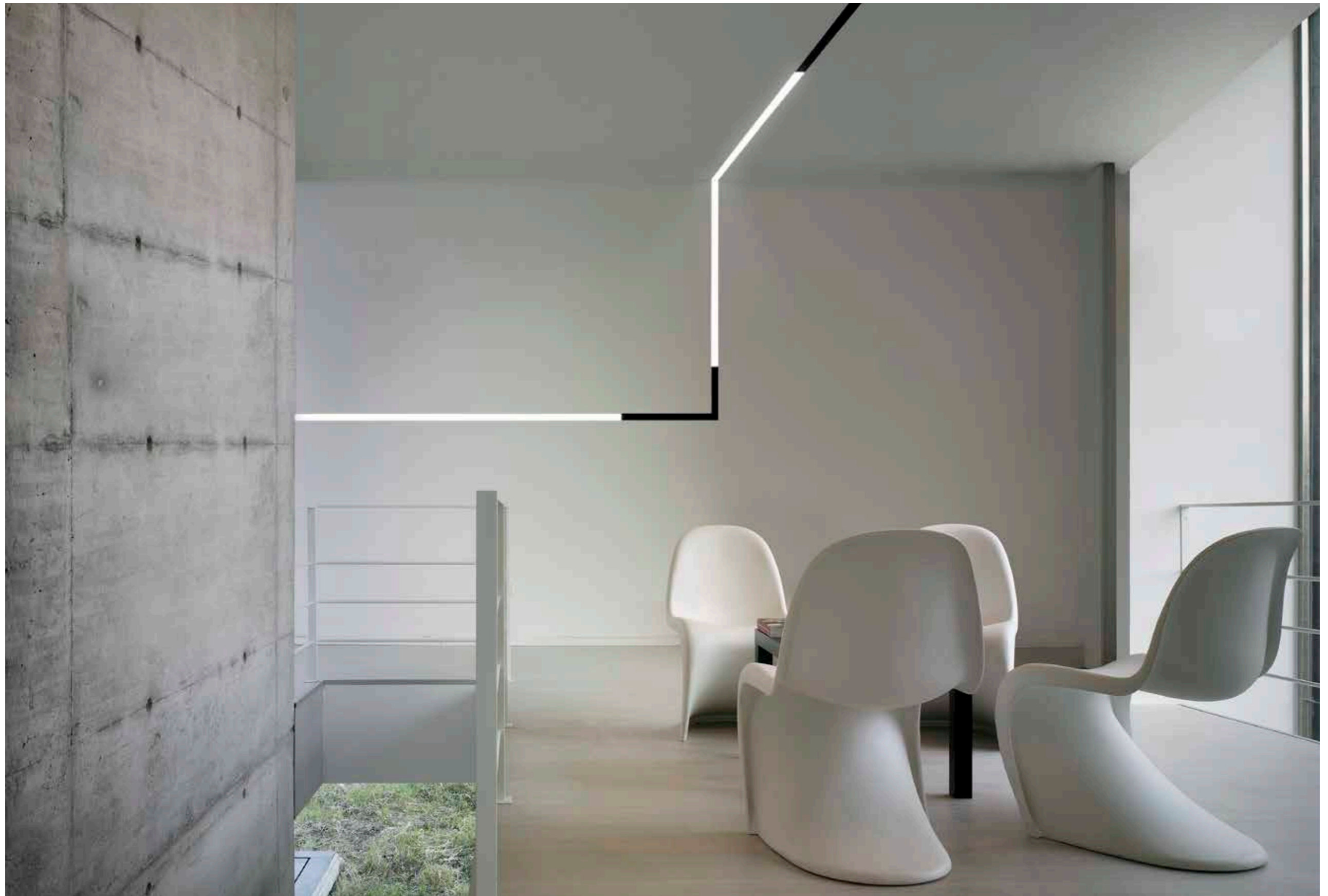



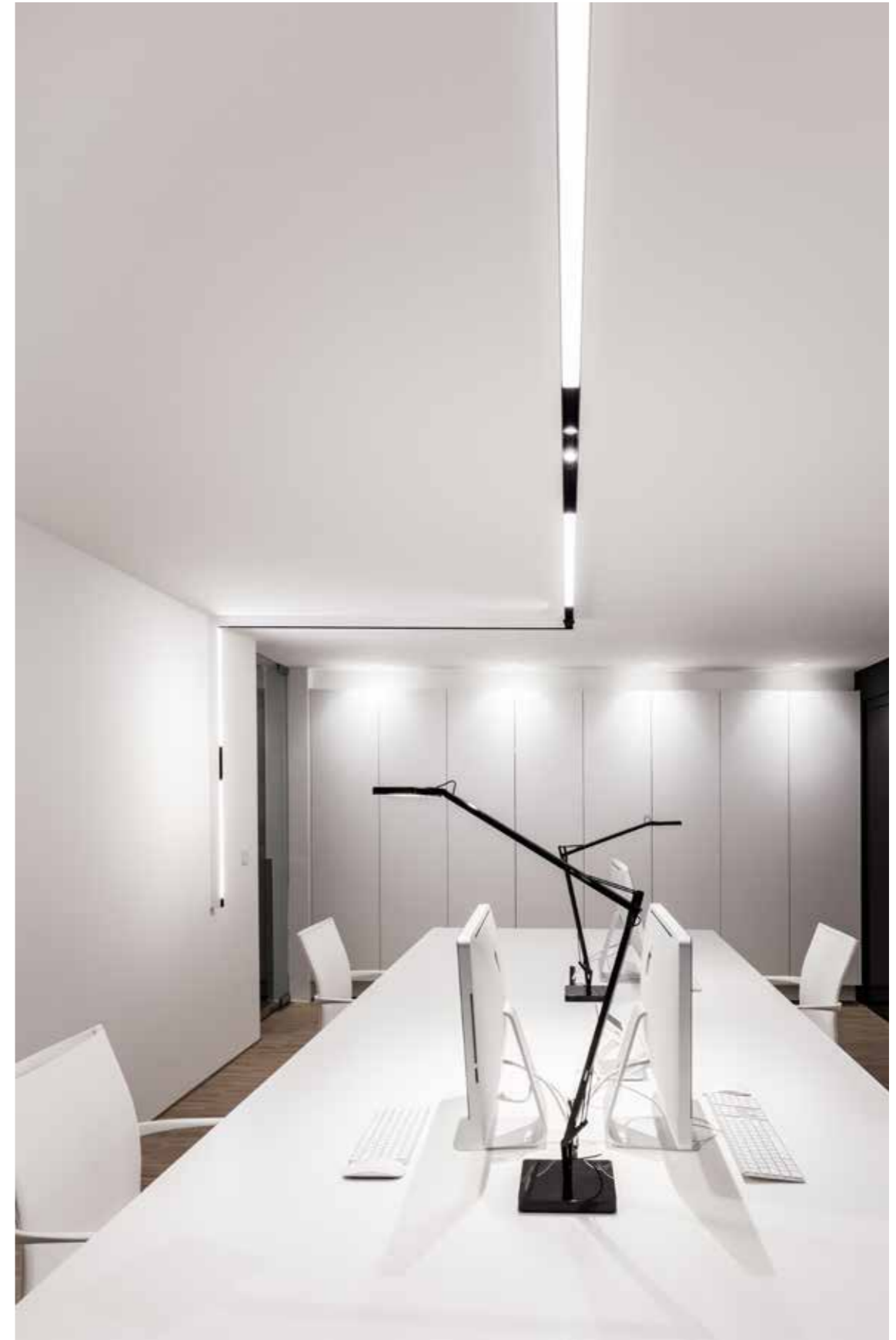



Verschiedene Kontrolloptionen, die jedes Bedürfnis decken können.

Different control options that can be adapted to any need.

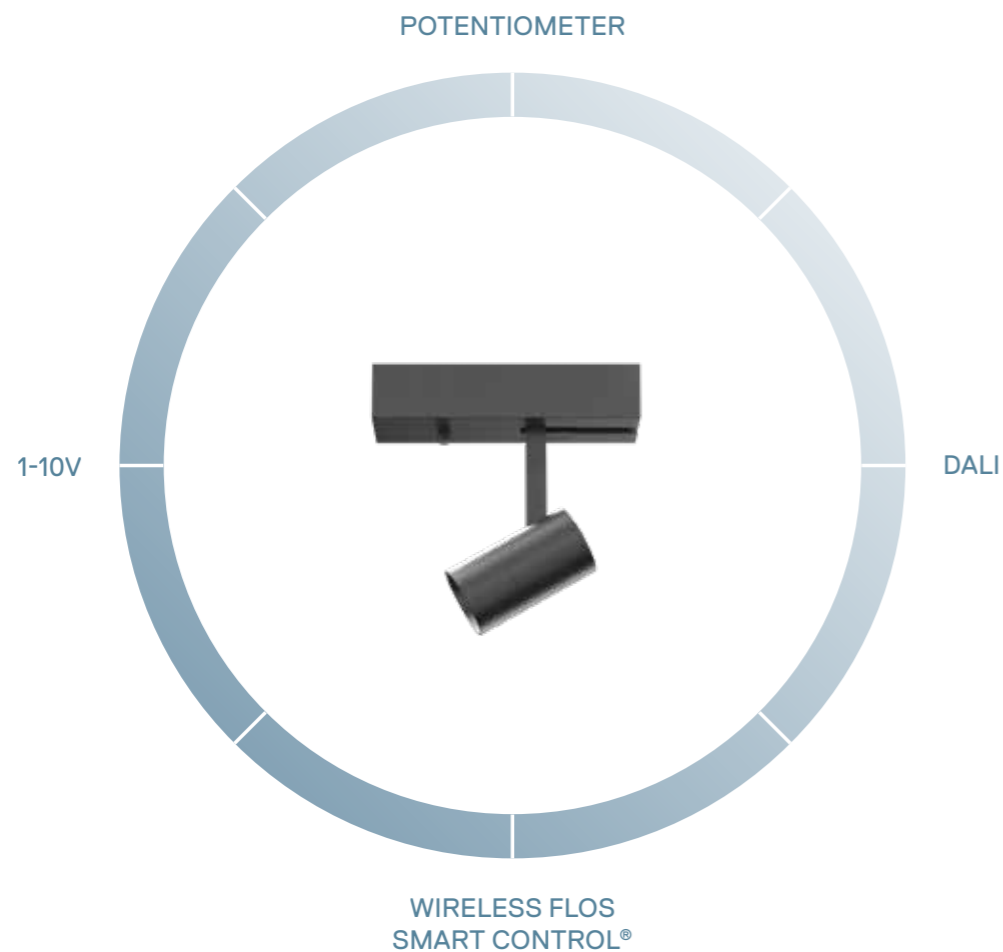

ON BOARD DIMMING: Jede Leuchte hat ihren eigenen integrierten Dimmer für direkte und individuelle Steuerung.

ON BOARD DIMMING: each luminaire has its own integrated dimmer for direct and individual control.

DALI: Individuelle Steuerung jeder Leuchte.

DALI: individual control of each luminaire.

1-10V: Broadcasting-Fernsteuerung (alle Leuchten in einer Gruppe gedimmt).

1-10V: broadcasting remote control (dimming of all the luminaires in a single group).

FLOS SMART CONTROL®: mit individueller Steuerung für jede Leuchte mit App auf Tablette oder Smartphone.

FLOS SMART CONTROL®: individual control of each luminaire directly through a tablet or smartphone application.

Die App FLOS SMART CONTROL® ermöglicht die Schaltung der Anlagenleuchten einzeln oder in Gruppen und so die Steuerung von Szenarien und Programmierung.

The FLOS SMART CONTROL® application allows you to control the system's luminaires individually or as a group, controlling scenes and programming.

Mit einer herkömmlichen Elektroinstallation und dem über Bluetooth angeschlossenen Gateway kann man stets genau die gewünschte Atmosphäre schaffen.

With a traditional electrical installation and the Gateway connected by Bluetooth, you obtain total control of the ambience.

Available for IOS and Android.

Für IOS und Android erhältlich.

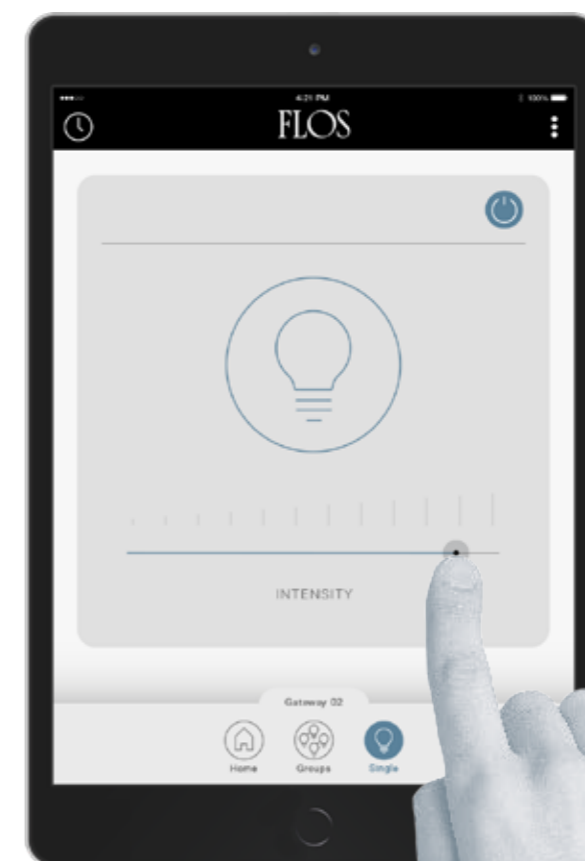

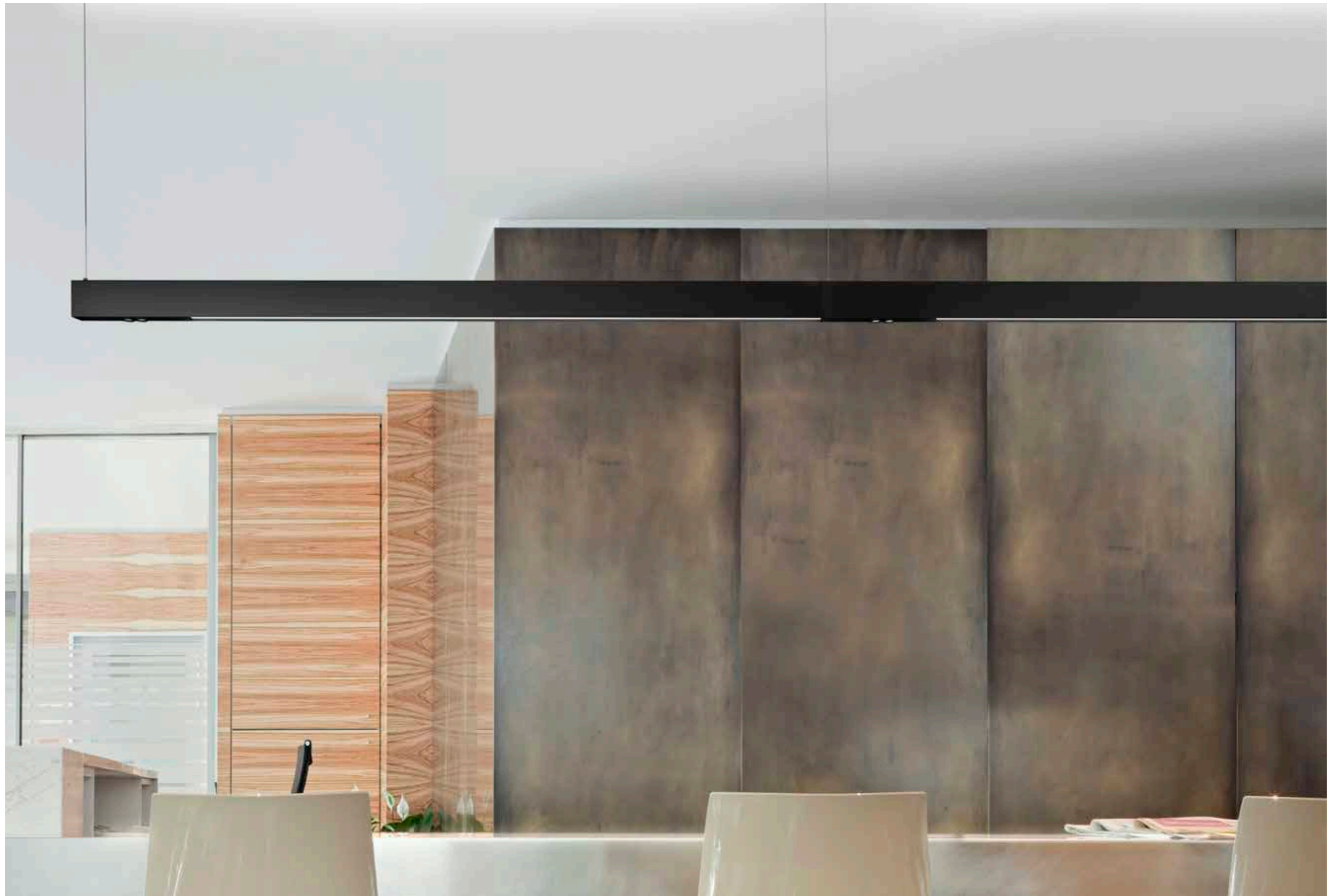

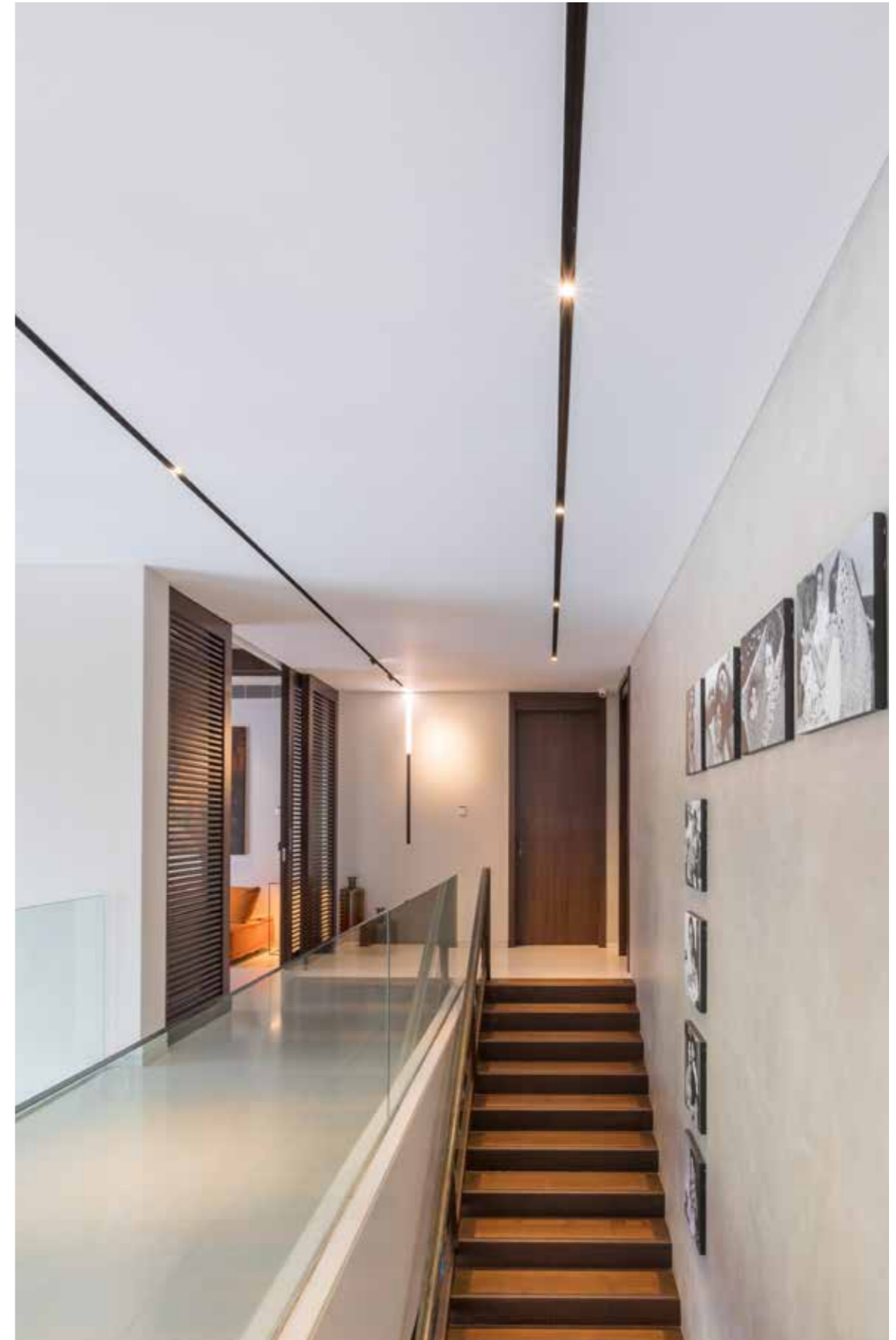

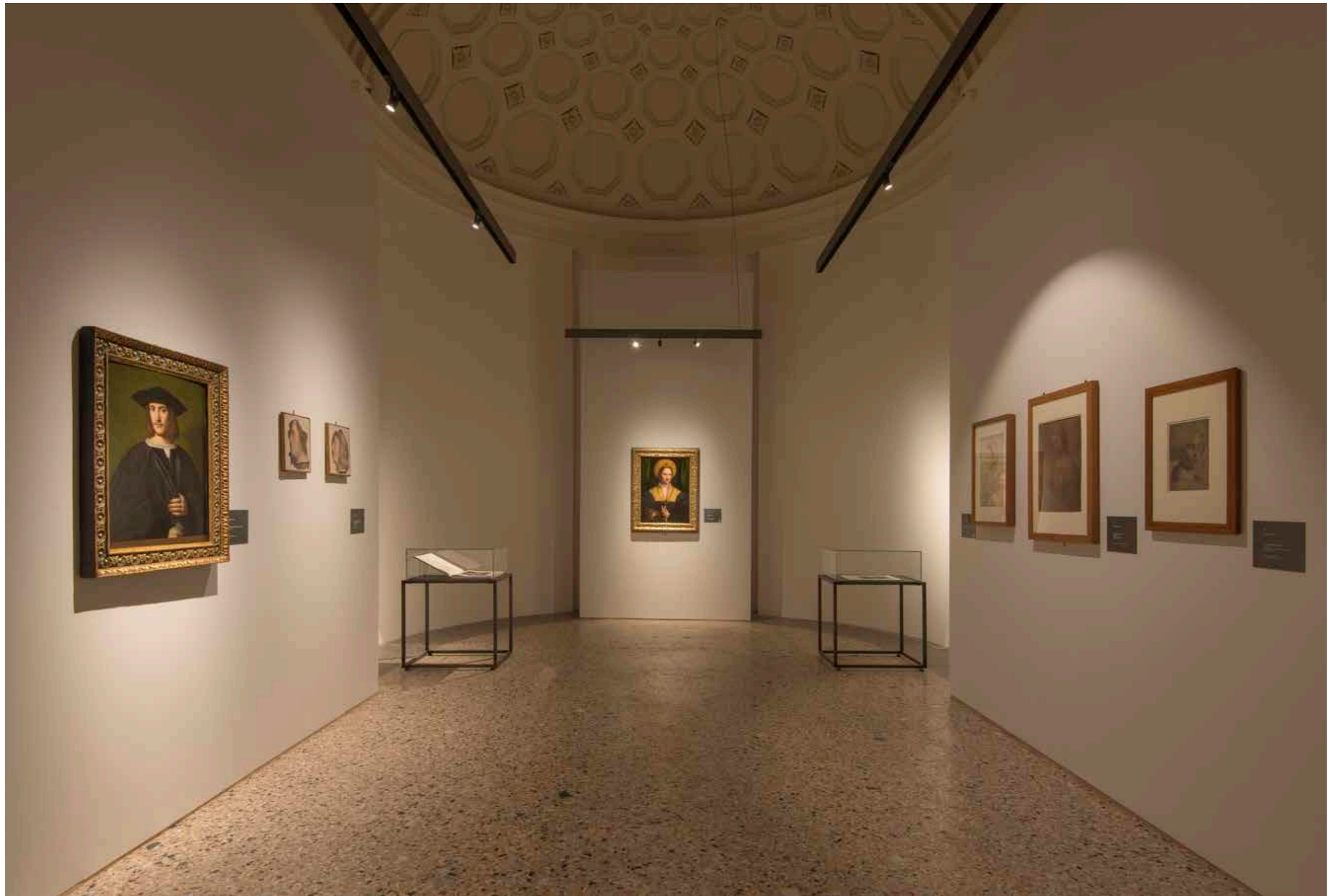

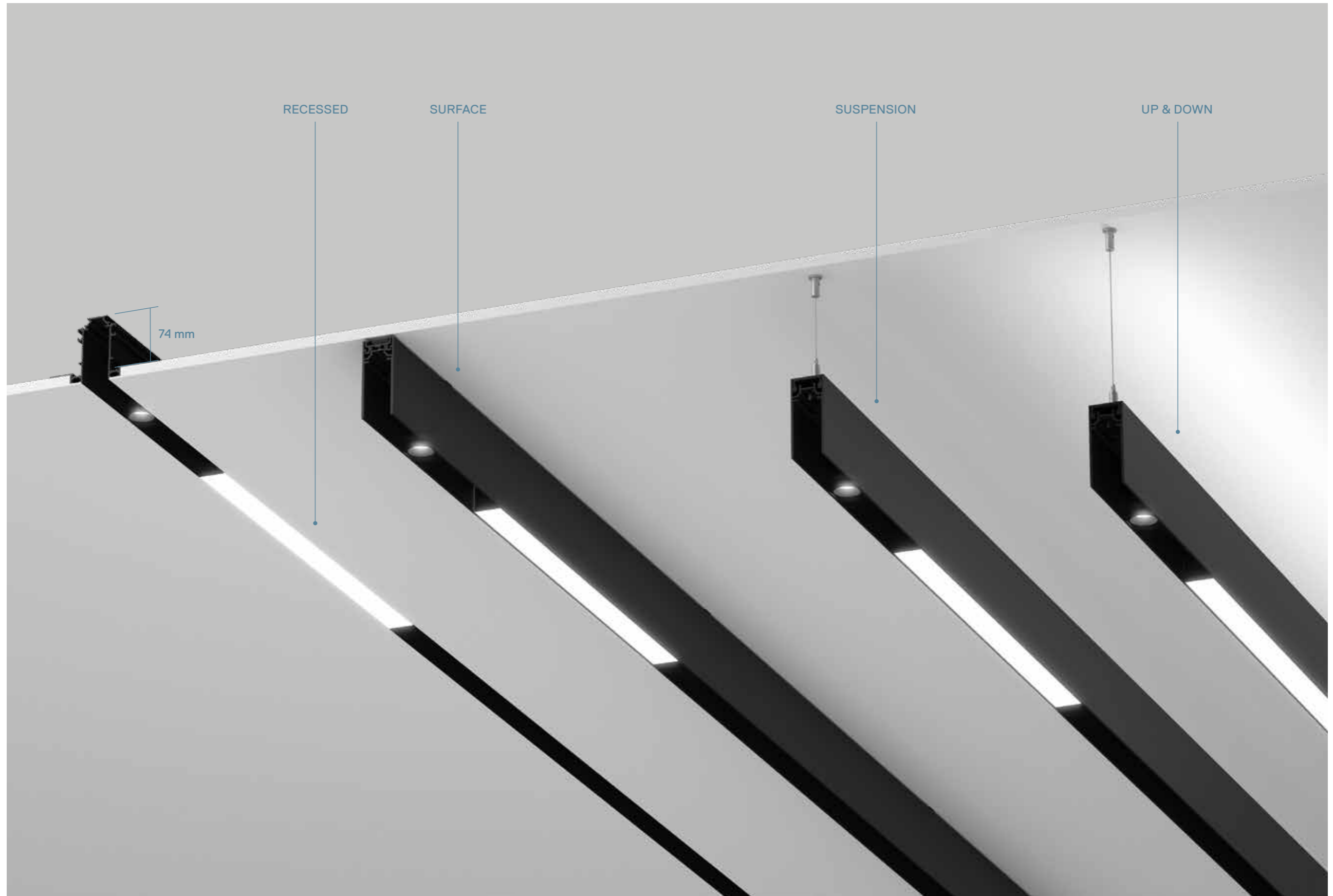



LIGHT MODULES

LIGHT STRIPE



TOP LED
25W/m

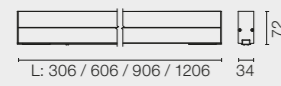

SPOT MODULE



POWER LED
8W

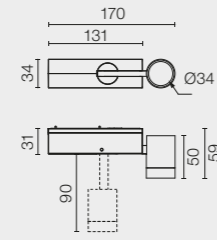

SPOT 120



POWER LED
12,5W/14W DALI

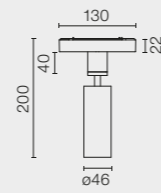

MULTI SPOT 4



POWER LED
10W

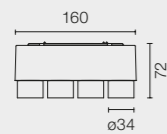

LIGHT SHADOW



POWER LED
10,8W

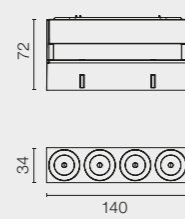

STRING LIGHT



POWER LED
16W

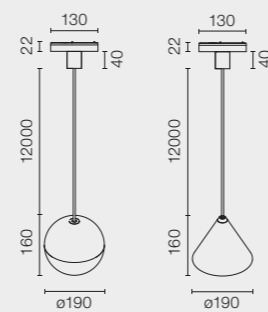

LIGHT MODULES

MINI GLO-BALL



POWER LED
7/3,5W

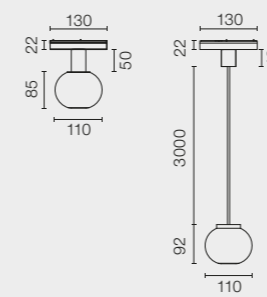

FIND ME SUSPENSION

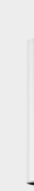

POWER LED
8W

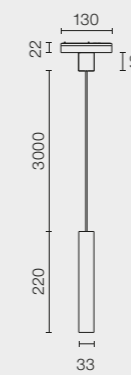

ANTHONY SPOT TRACK



POWER LED
16W

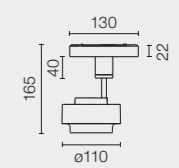

RECESSED



14 Schwarz
14 Black

SURFACE



40 Weiss
40 White

SUSPENSION
UP&DOWN / DOWN



14 Schwarz
14 Black



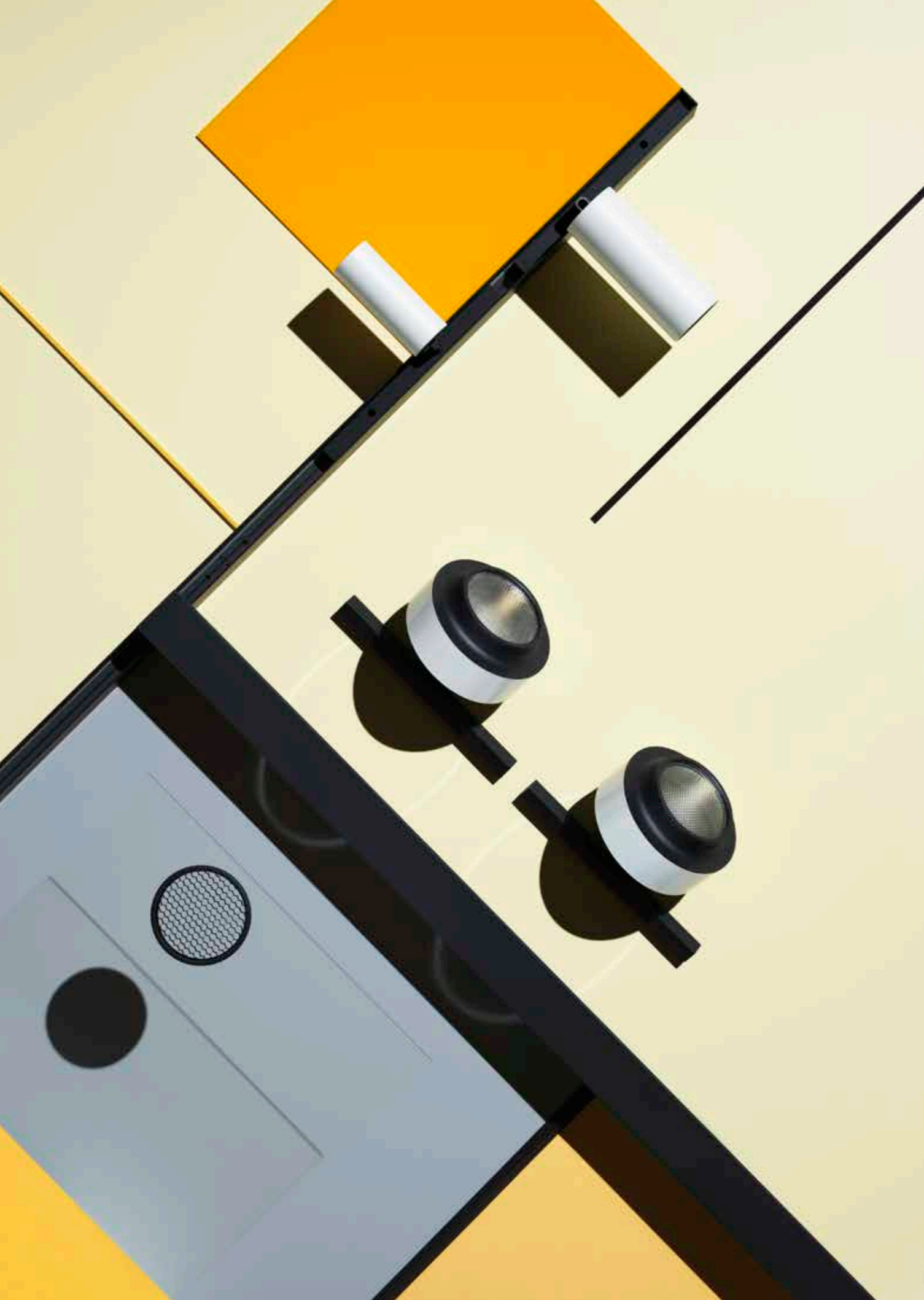

THE TRACKING MAGNET

Kompaktes Profil, mit der magnetischen Befestigung von Beleuchtungskörpern kompatibel. Das Programm hat Einbau, Anbau- sowie Pendelausführungen. Einstellung und Steuerung mit Universalprotokollen und mit FLOS SMART CONTROL[®]-Anwendung.

THE TRACKING MAGNET

Compact profile, compatible with magnetic fastening light fixtures. The program has recessed, surface and suspended versions. Regulation and control with universal protocols and using the FLOS SMART CONTROL[®] application.



DESIGNED BY FLOS ARCHITECTURAL

Eine minimale Linie, nur 15 mm breit, die durch die extreme Verkleinerung der Elektronik und des Optikkörpers erreicht wird. The Tracking Magnet bietet eine komplette Kollektion von Lichtinstrumenten für jeden Bedarf, kompatibel mit allen bekannten Steuerungssystemen und FLOS SMART CONTROL®. Die magnetische Befestigung bietet eine absolut freie Konfiguration innerhalb des Raums.

A minimal line only 15 mm wide, achieved through the extreme miniaturization of the electronics and the optical bodies. The Tracking Magnet offers a complete collection of lighting tools for any need, compatible with all main control systems and FLOS SMART CONTROL®. Its magnetic installation gives total freedom to be configured in space.

15 mm



Von FLOS patentierter Graphitkern. Das in unserer Technologie eingesetzte Graphit ermöglicht optimale Datenübertragung und bietet - da schwarz wie das übrige Innenprofil - maximale Integration.

Graphite core patented by FLOS: thanks to our technology, the graphite allows optimal transmission of data with maximum integration, as it is black like the rest of the profile interior.

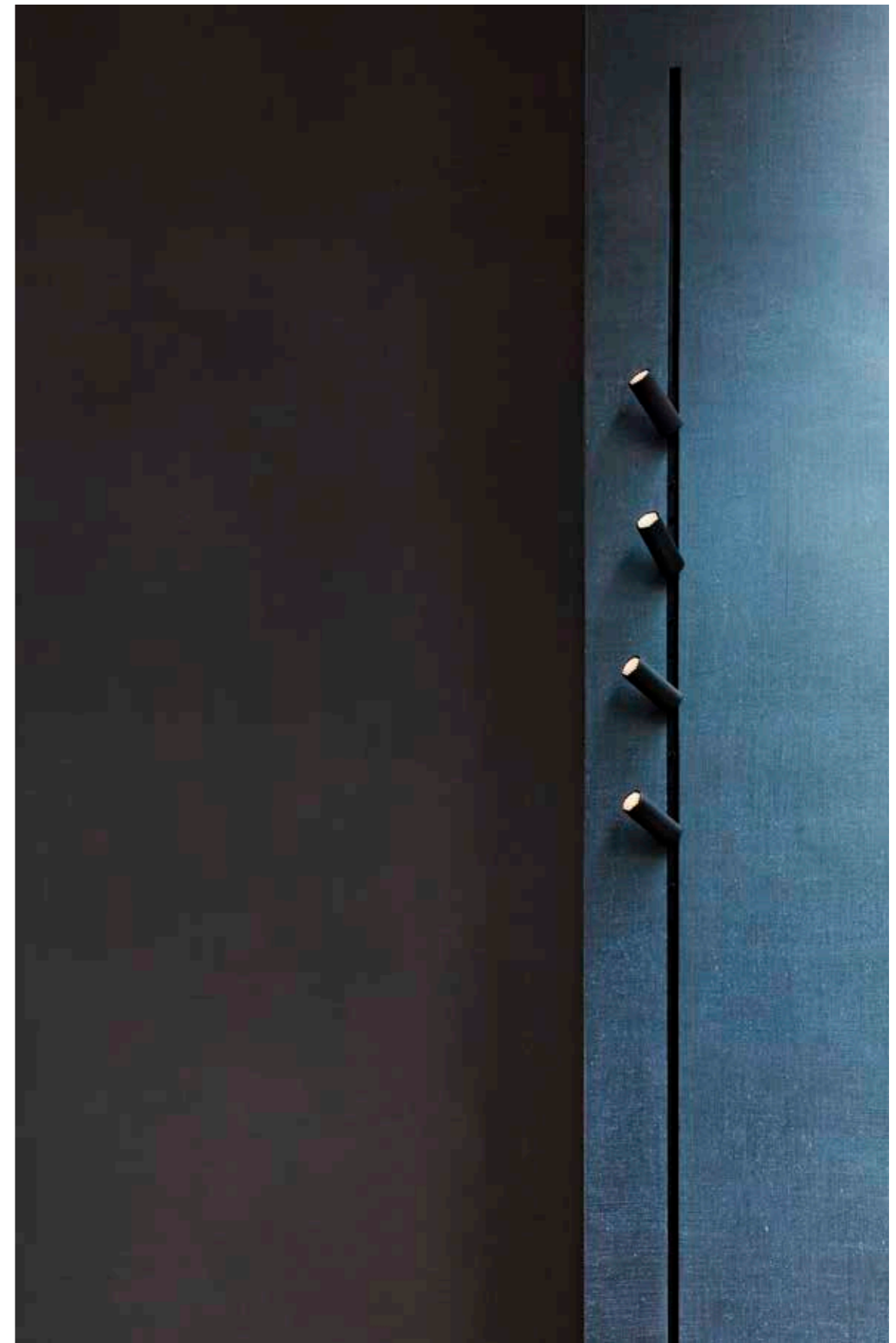

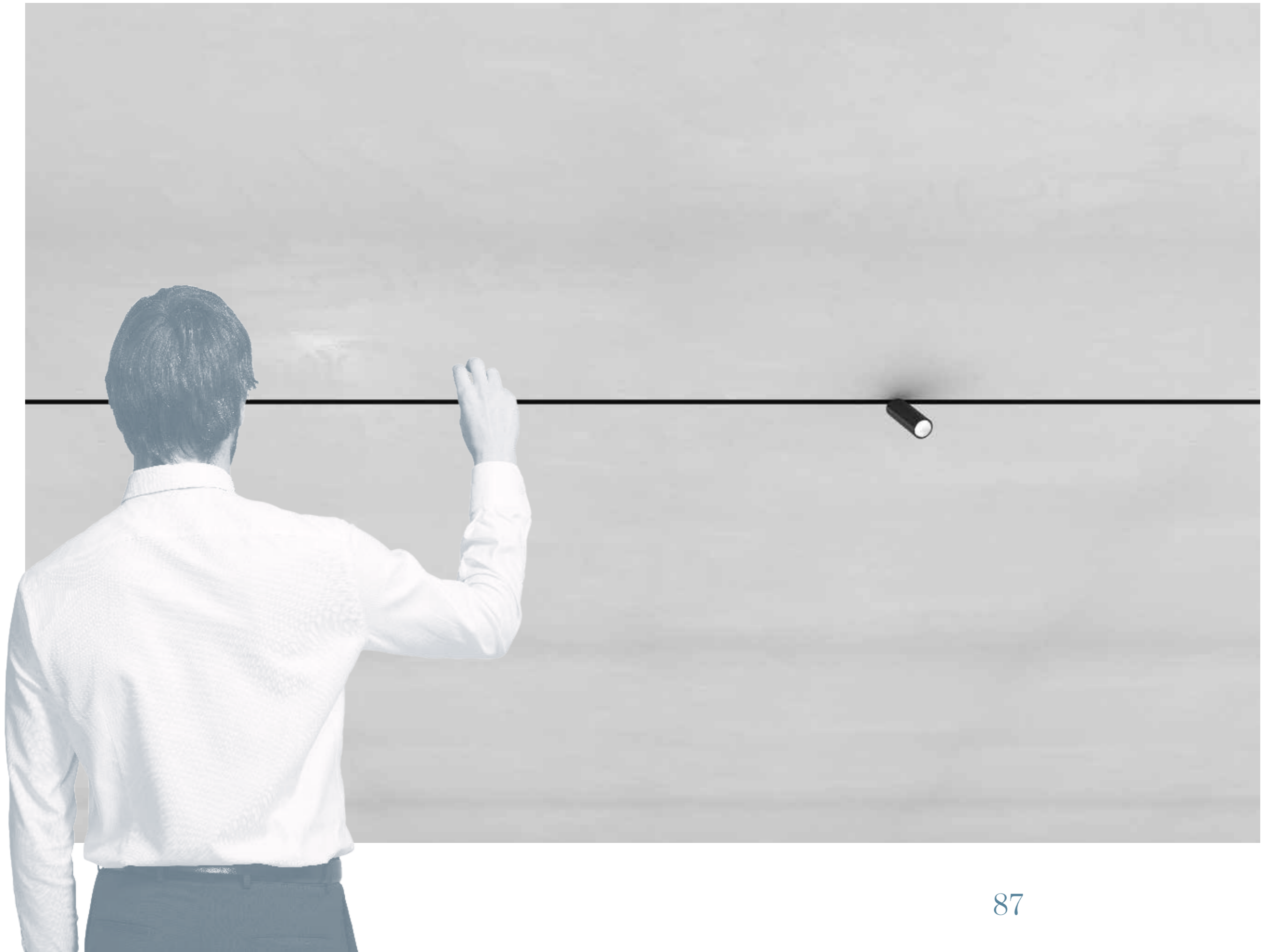



Magnetische Anbringung der Leuchten, die sich im Warmzustand handhaben und sich im weiterhin eingeschalteten Zustand versetzen lassen. Dies sorgt für stets enorme Flexibilität und Anpassungsfähigkeit in der Leuchtenanordnung.

Magnetic fixing of the luminaires, which allows hot handling. They can be moved while the track is connected, achieving enormous flexibility and adaptability in the configuration at any time.



LIGHT STRIPE

Magnetische Lichtleisten in verschiedenen Längen erhältlich. Diese können aneinandergereiht werden, wodurch sich der GAP-Effekt (Unterbrechung des Lichts an den Stoßstellen) - sogar in Ecken - verhindern lässt.

Der speziell entwickelte Opaldiffusor sorgt für eine effiziente, homogene architektonische Integration.

Magnetic light bar available in different lengths, which offers the possibility of joining and eliminating the gap effect, even in corners.

The specially developed opal diffuser guarantees both efficiency and homogeneity in architectural integration.

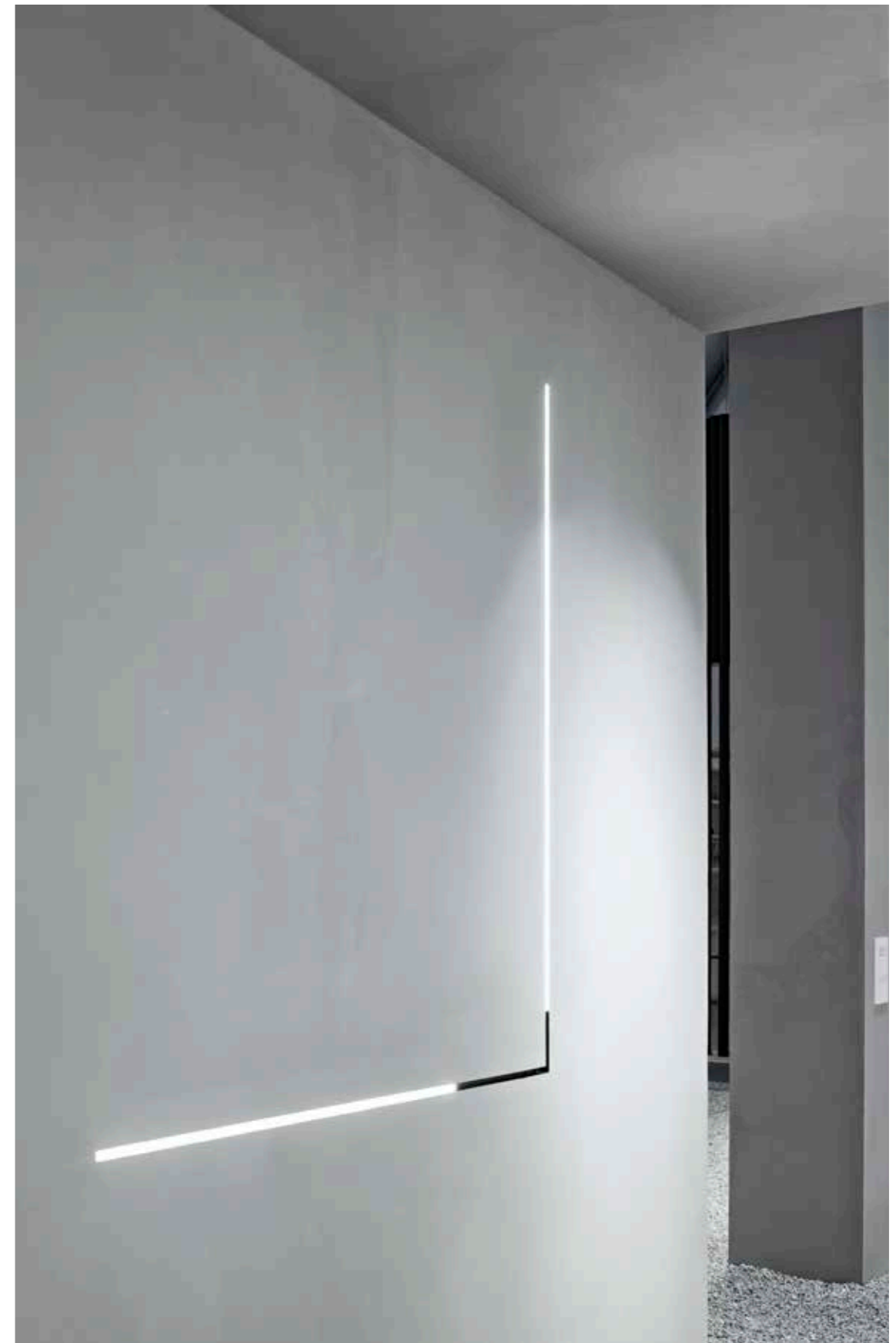
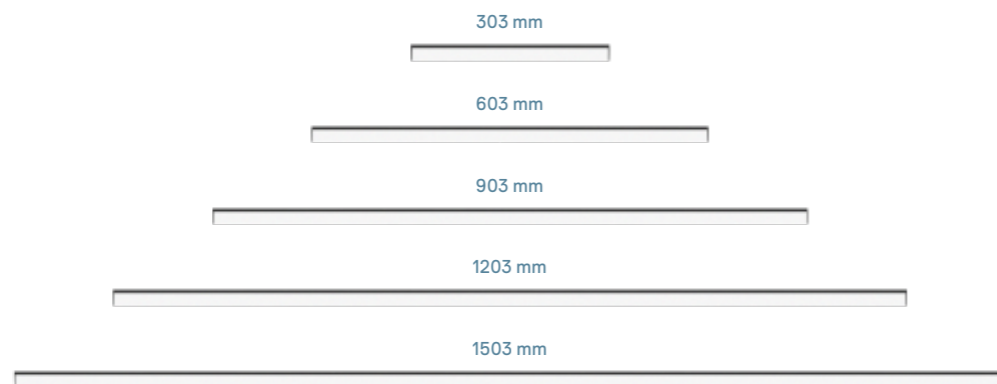

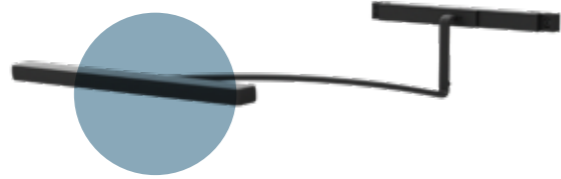

WALLEE

Von Designer Niels Bendtsen speziell für die Bild- und Wandbeleuchtung konzipierte Leuchte mit homogener, eleganter Verteilung von hochwertigem Licht.

Luminaire designed especially by Niels Bendtsen for lighting frames and walls, thanks to its homogenous and elegant distribution of high-quality light.

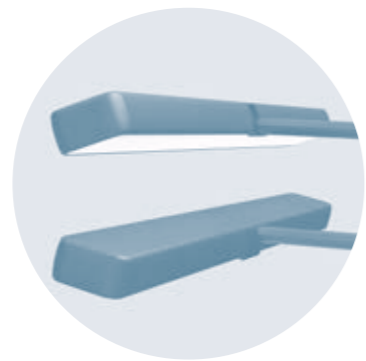

Für perfekte Lichtanpassung ist der Lichtkopf 50°drehbar.

Head adjustable to 50 degrees for the perfect light setting.





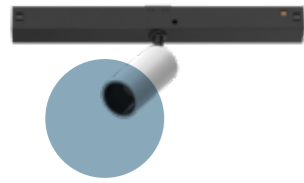

SPOT TRACKING 50

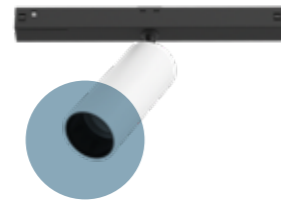

SPOT TRACKING 90

Strahler-Produktserie mit jeweils unterschiedlicher Leistung und Optik für jeden Bedarf.

Family of spots with different powers and optics for any need.



SPOT TRACKING 120



Für Komfort und Dämpfung sind alle Strahler mit einem zylinderförmigen Schirm ausgestattet.

All projectors include a shield cylinder to guarantee comfort and shielding.

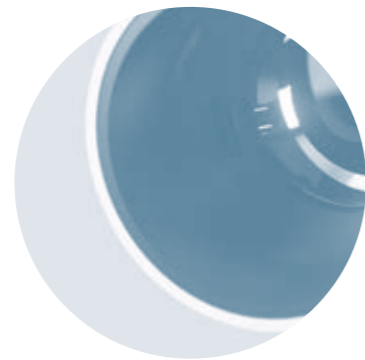

Ausführungen mit Optik für feinere, kontrolliertere Lichtstrahlen (Ausführung Spot 50, 90 und 120).

Versions with lenses which offer narrower and more controlled light beams (spot 50, 90 and the 120 version).

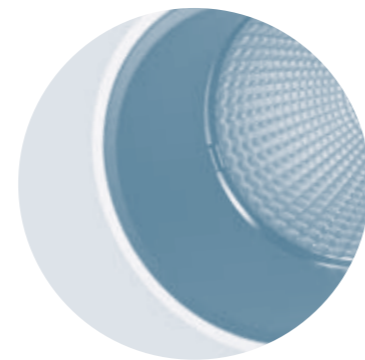

Spot-Ausführungen 120 und 150 mit Spiegeloptik für offenere, leistungsfähigere Lichtstrahlen erhältlich.

Spot versions 120 and 150 with reflector optics available, to offer wider and more powerful light beams.



SPOT TRACKING 150



ANTHONY SPOT

Anthony Spot von Designer Antonio Citterio - schlichte, elegante Form mit einem Hauch Design, die sich von traditionellen Konzepten abhebt.

Anthony Spot designed by Antonio Citterio: a form with a touch of avant-garde design, simple yet elegant, which is distanced from the traditional looks.

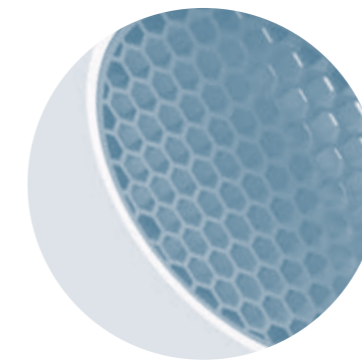

Für stets maximalen Sehkomfort ist für alle Strahler Schirmzubehör erhältlich.

Shielding accessories available in all projectors, to always offer maximum visual comfort.

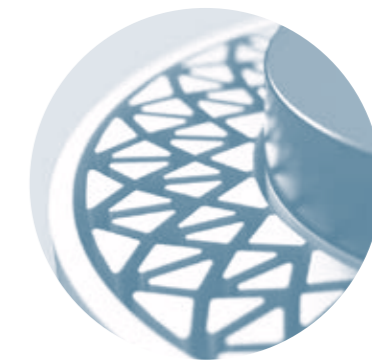

Innovative Wärmeableiter-Konstruktion.

Novel heat dissipater design.

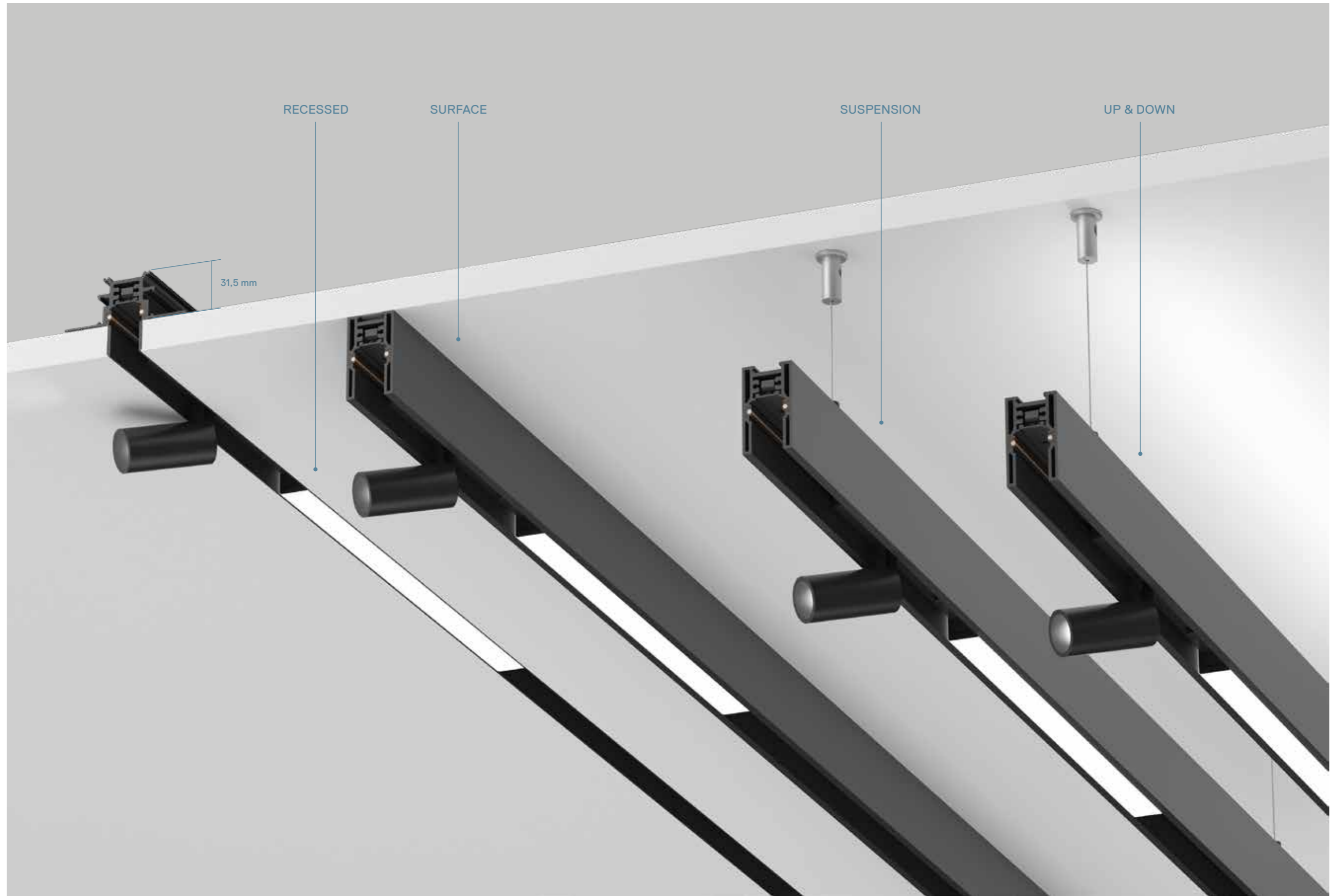



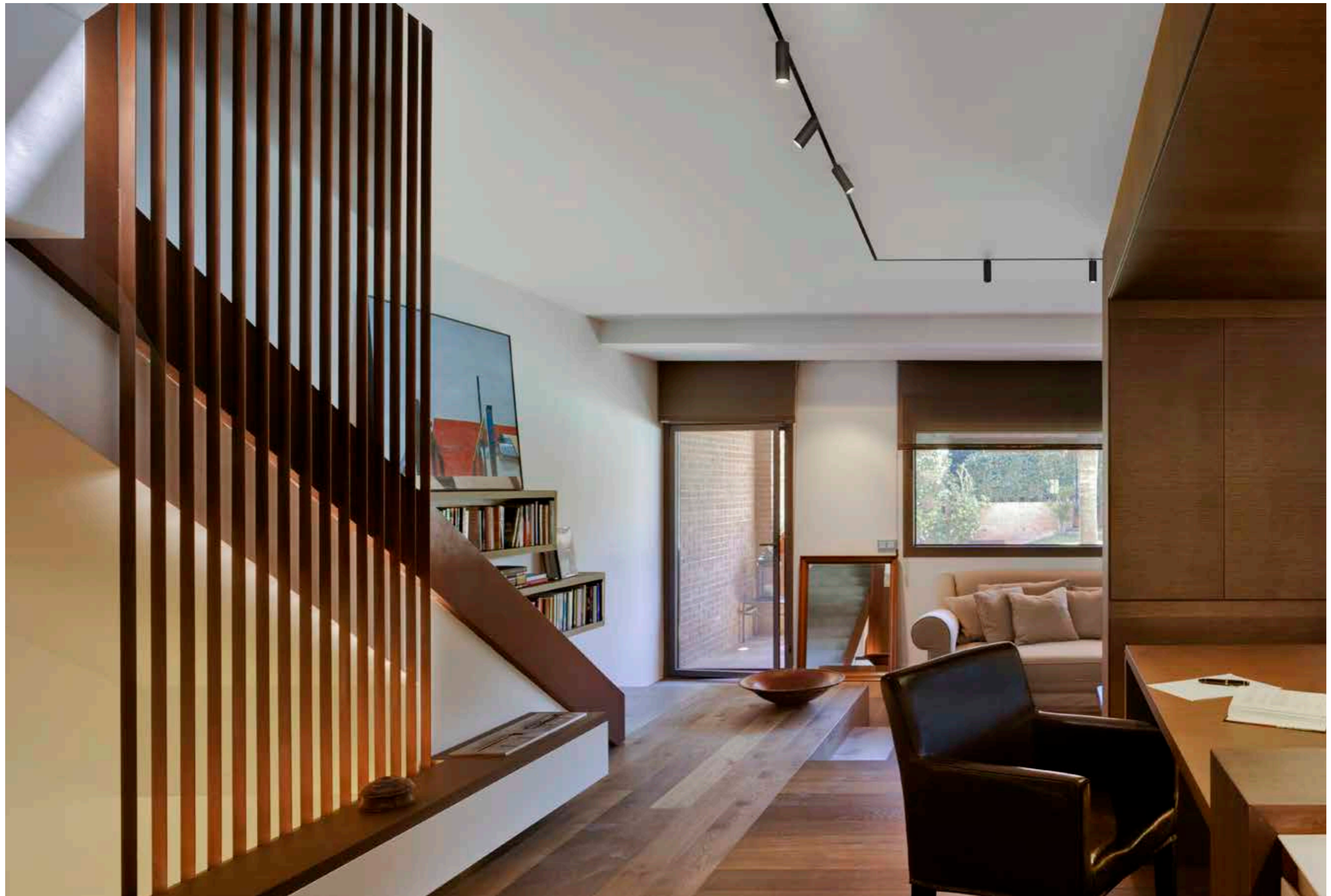

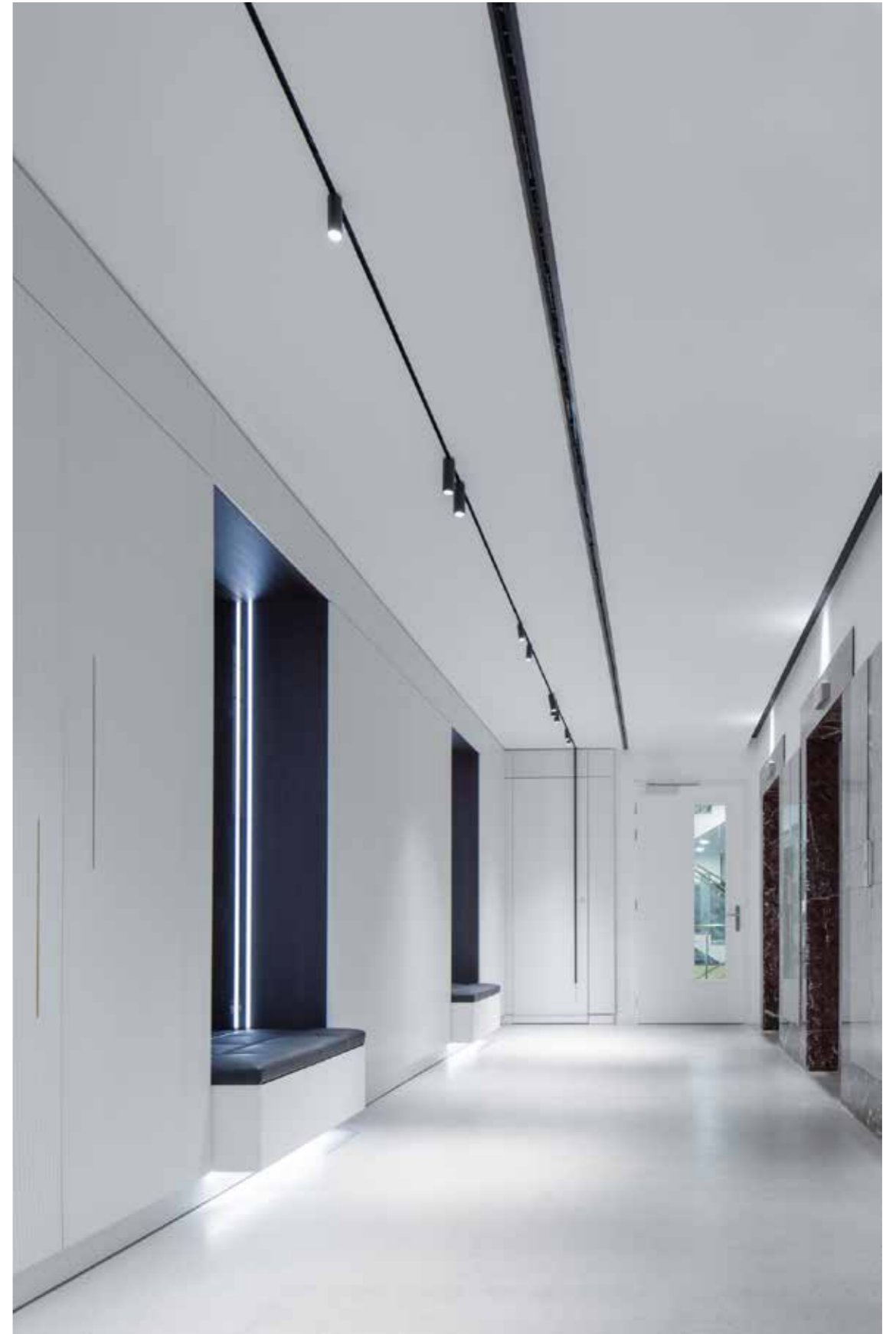

Verschiedene Kontrolloptionen, die jedes Bedürfnis decken können.

Different control options that can be adapted to any need.

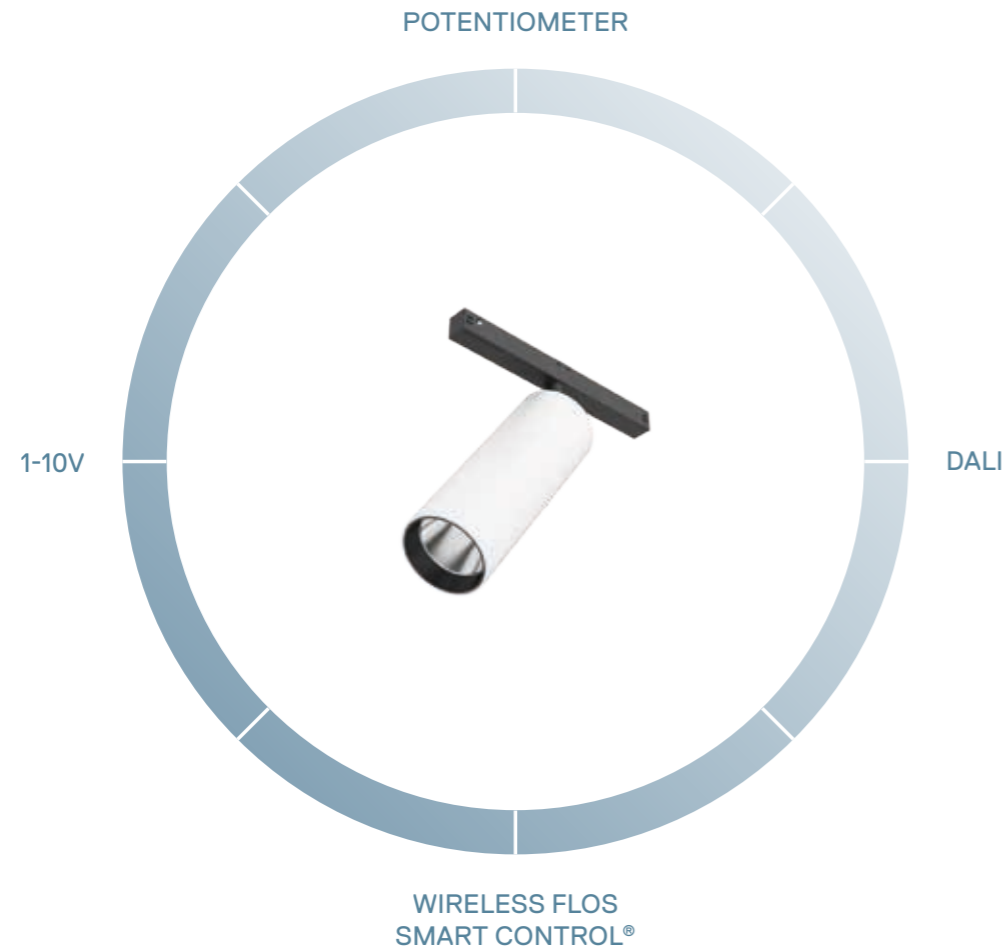

ON BOARD DIMMING: Jede Leuchte hat ihren eigenen integrierten Dimmer für direkte und individuelle Steuerung.

ON BOARD DIMMING: each luminaire has its own integrated dimmer for direct and individual control.

DALI: Individuelle Steuerung jeder Leuchte.

DALI: individual control of each luminaire.

1-10V: Broadcasting-Fernsteuerung (alle Leuchten in einer Gruppe gedimmt).

1-10V: broadcasting remote control (dimming of all the luminaires in a single group).

FLOS SMART CONTROL®: mit individueller Steuerung für jede Leuchte mit App auf Tablette oder Smartphone.

FLOS SMART CONTROL®: individual control of each luminaire directly through a tablet or smartphone application.

Die App FLOS SMART CONTROL® ermöglicht die Schaltung der Anlagenleuchten einzeln oder in Gruppen und so die Steuerung von Szenarien und Programmierung.

The FLOS SMART CONTROL® application allows you to control the system's luminaires individually or as a group, controlling scenes and programming.

Mit einer herkömmlichen Elektroinstallation und dem über Bluetooth angeschlossenen Gateway kann man stets genau die gewünschte Atmosphäre schaffen.

With a traditional electrical installation and the Gateway connected by Bluetooth, you obtain total control of the ambience.

Available for IOS and Android.

Für IOS und Android erhältlich.



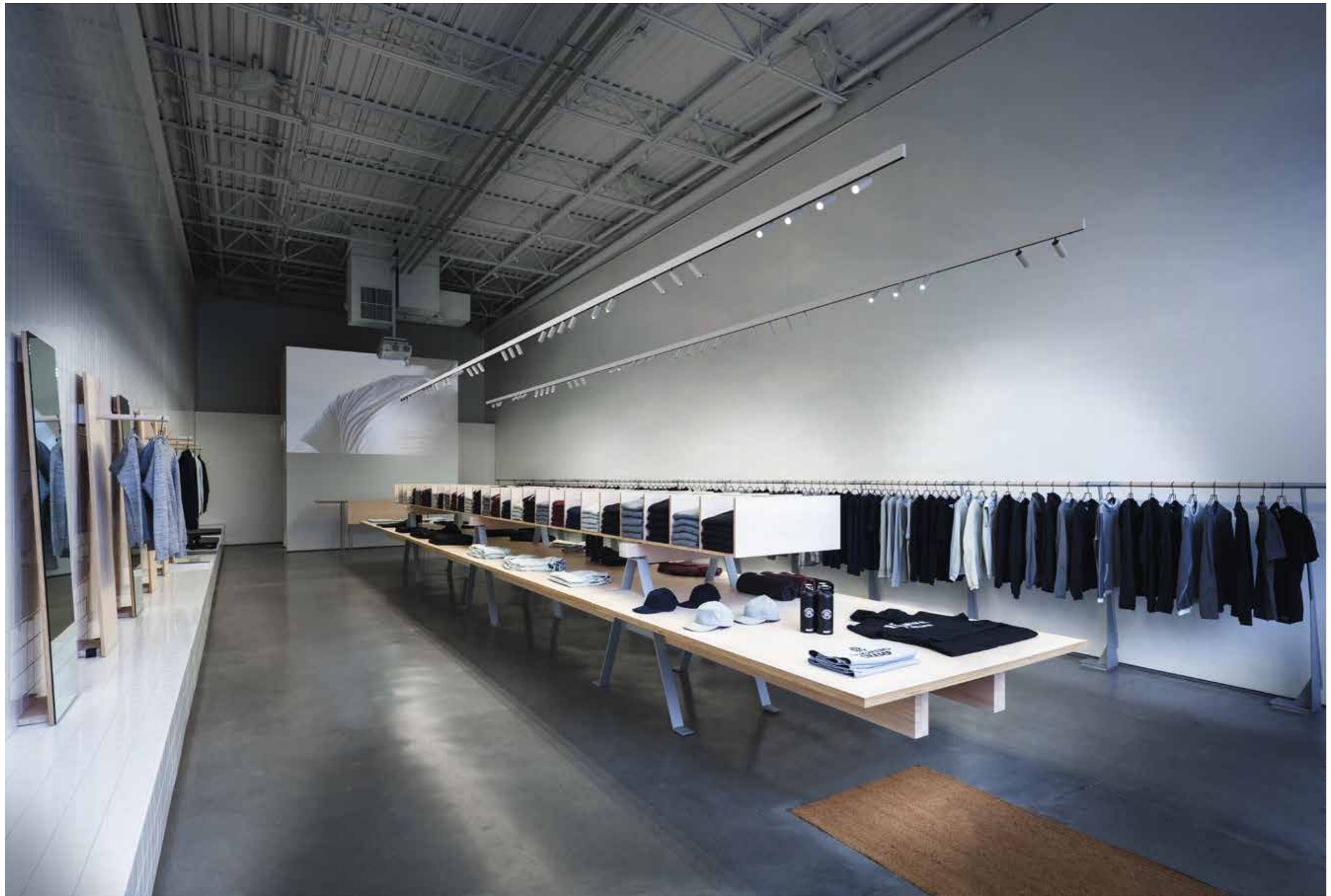

LIGHT MODULES

LIGHT STRIPE



TOP LED
20W/m

SPOT 50

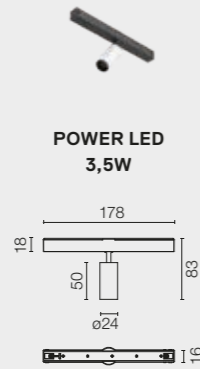

POWER LED
3,5W

SPOT 90

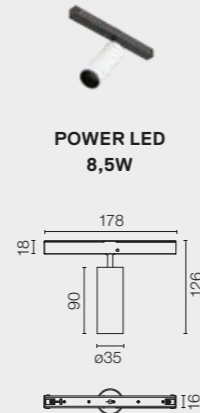

POWER LED
8,5W

SPOT 120

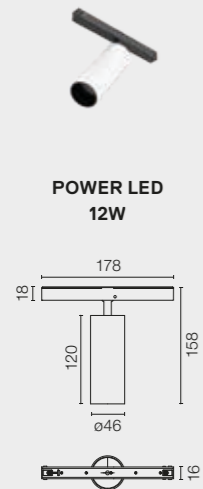

POWER LED
12W

SPOT 120

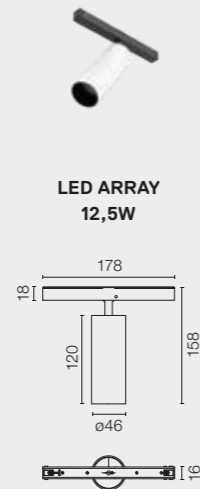

LED ARRAY
12,5W

SPOT 150

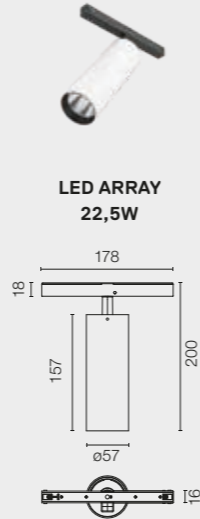

LED ARRAY
22,5W



Spot

Medium

Flood

LIGHT MODULES

WALLEE

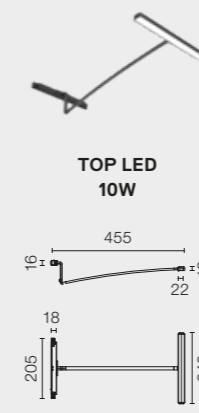

TOP LED
10W

ANTHONY SPOT TRACK

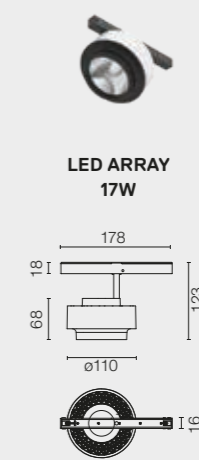

LED ARRAY
17W

RECESSED



14 Schwarz
14 Black

SURFACE



40 Weiss
40 White

SUSPENSION
UP&DOWN / DOWN



05 Chrom
05 Chrome

14 Schwarz
14 Black

FLOS
SMART CONTROL



THE TRACKING POWER

3-Phasen-Stromschiene mit reduzierten Abmessungen in der Einbau- und Anbauversion. Mit einem kompakten und leistungsstarken Beleuchtungskörperprogramm kompatibel. Hocheffiziente Reflektoren.

THE TRACKING POWER

3-phase rail with reduced dimensions in its recessed and surface version. Compatible with a compact and powerful light fixture program. High efficiency reflectors.



DESIGNED BY FLOS ARCHITECTURAL

Die 3-Phasen-Stromschiene gemäss FLOS. Dank seines sehr kleinen Befestigungssystems kann man auf einer Breite von nur 15 mm eine komplette Auswahl von professionellen hochleistungsfähigen Lichtinstrumenten einsetzen.

The three-phase rail according to Flos. Thanks to its miniaturized anchorage system it is capable to host in a space of only 15 mm a complete range of high power lighting tools for professional applications.

Revolutionäres Schienendesign, das vollständige Integration in der 15 mm Linie ermöglicht.

Revolutionary track design that allows total integration in the 15mm line.

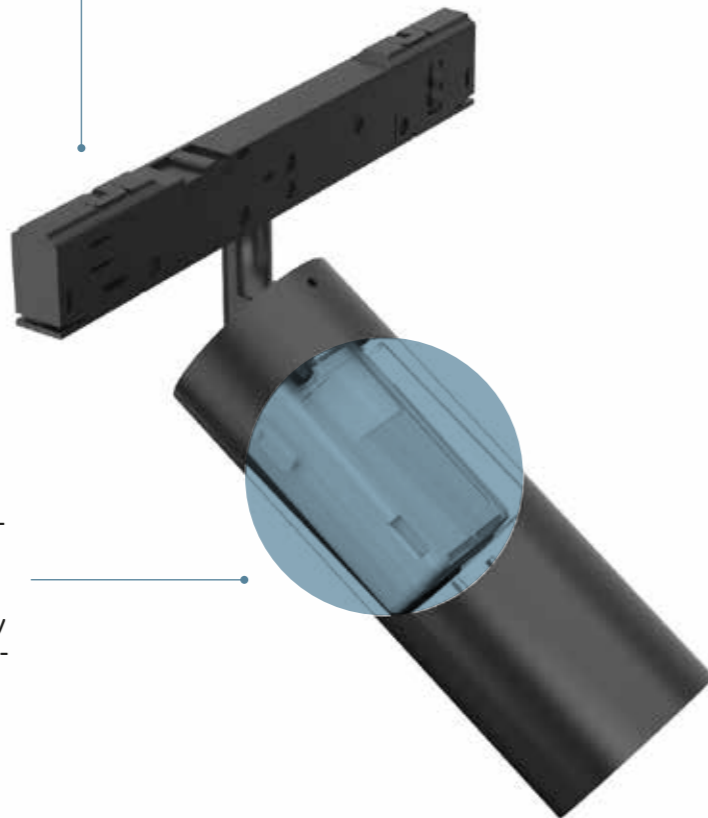

Steuerelektronik vollständig in den Strahlerkopf integriert.

Control electronics totally integrated into the projector head.



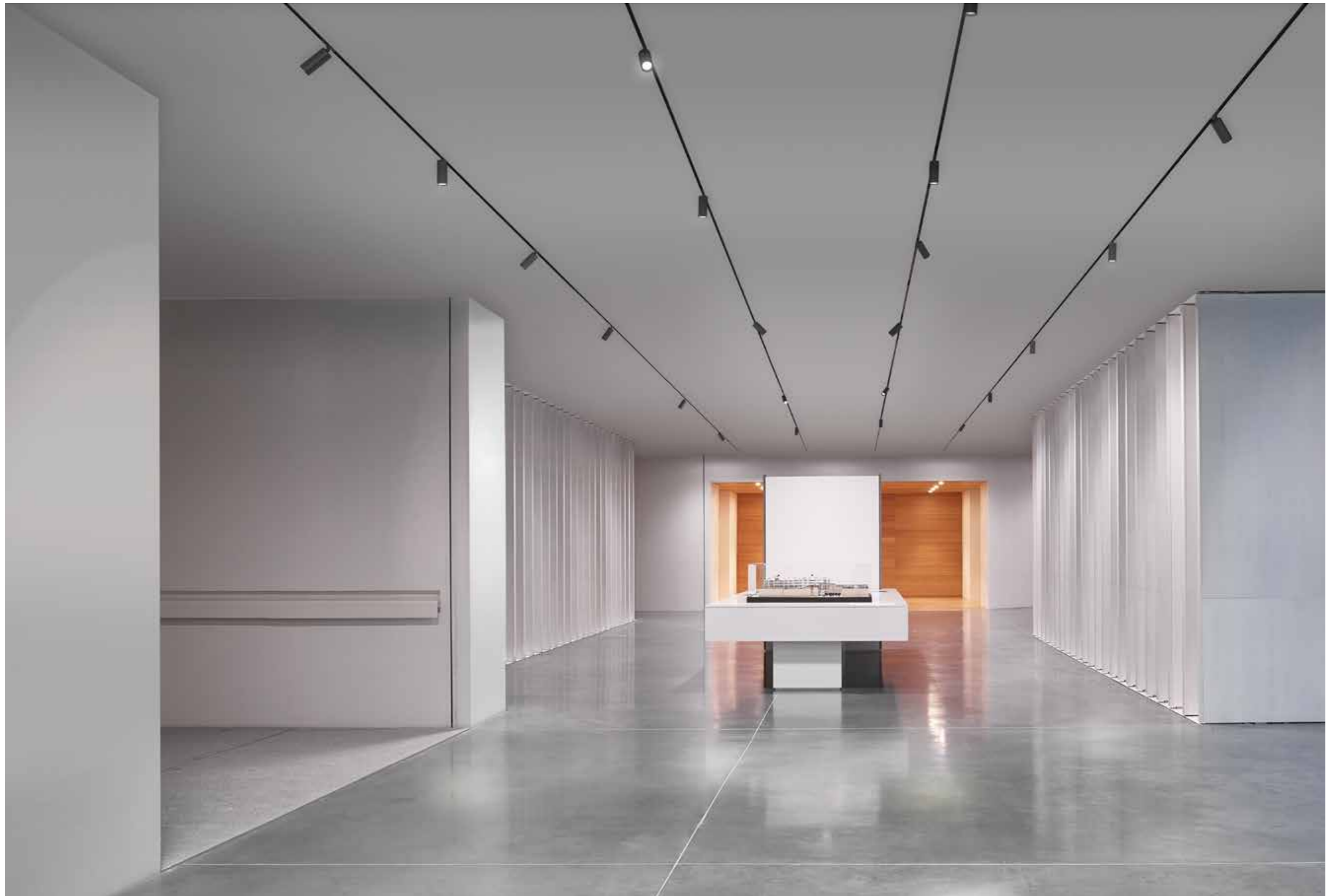

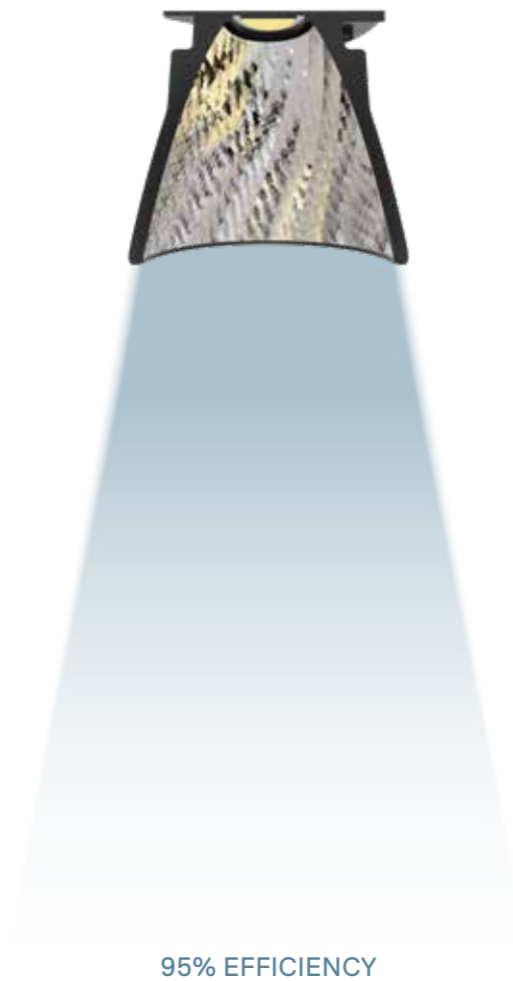
FLOS CRYSTAL
REFLECTOR TECH

Revolutionärer Strahler aus Borosilikatglas mit einer Lichtausbeute von bis zu 95%. Seine Facettierung sorgt für eine vollkommene Kontrolle des Lichtstrahls.

Revolutionary reflector in borosilicate glass that offers light efficiency of up to 95%. Thanks to its faceting, it guarantees total control of the light beam.

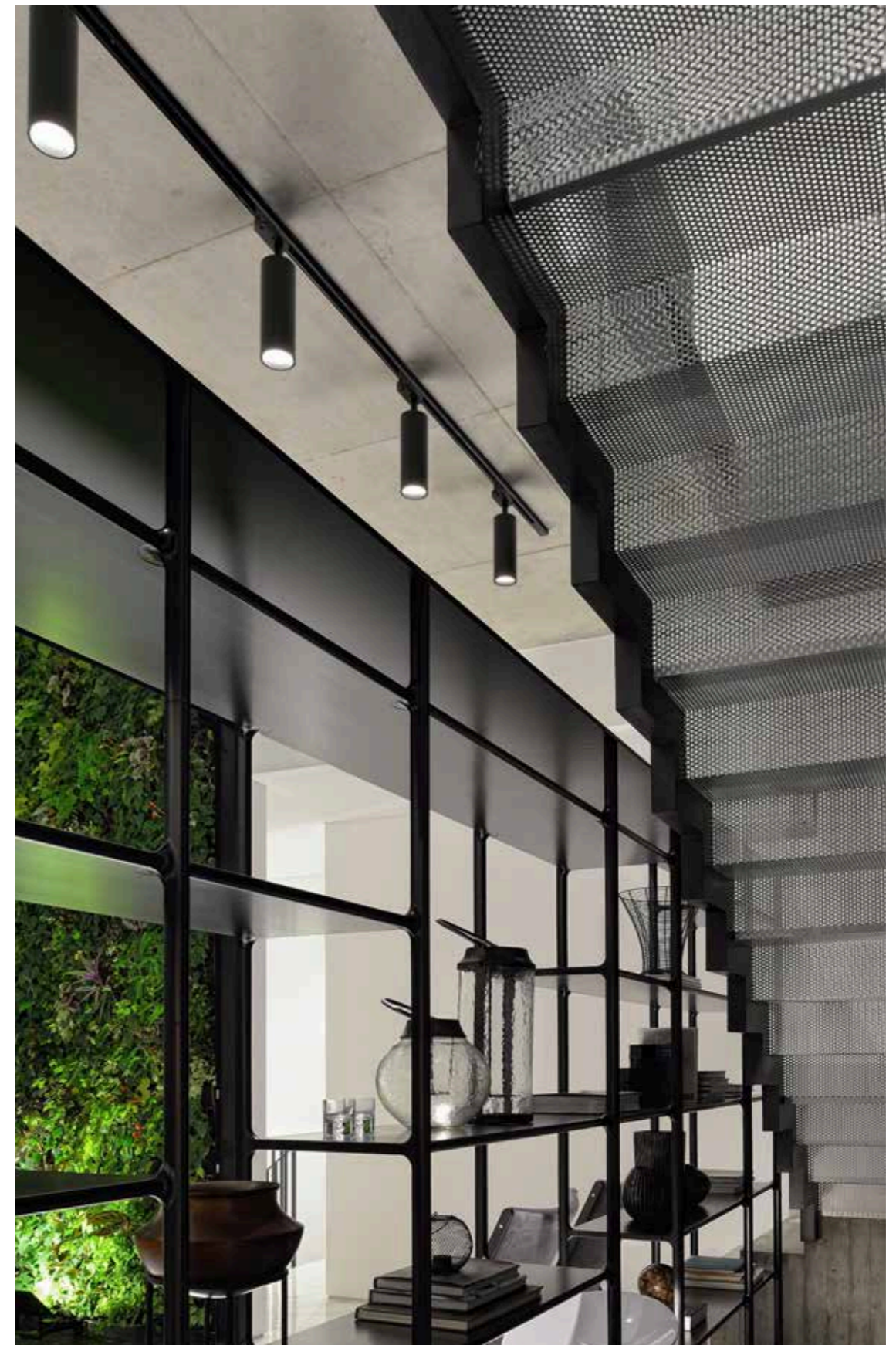

Dieser Strahler besitzt ein innovatives einstellbares System mit bifokaler Dual-Optik, mit der sich der Öffnungswinkel des Lichtstrahls bei weiterhin hohem Wirkungsgrad zwischen 13° und 56° verstellbar lässt.

This projector incorporates an innovative adjustable system with double bifocal lenses, which allows the light beam opening angle to be controlled from 13 degrees to 56 degrees, while maintaining high levels of efficiency.



SPOT 175 LENS



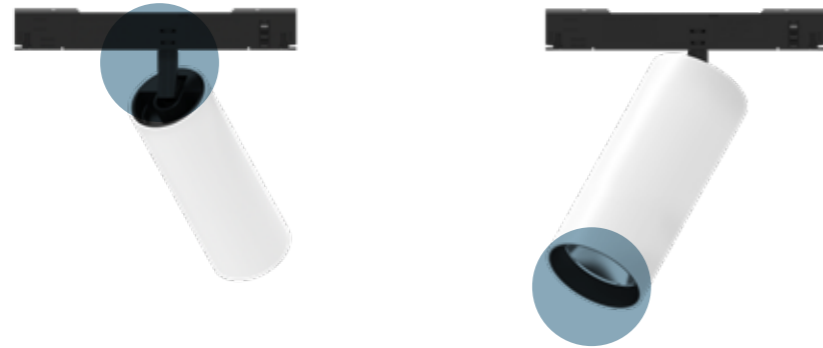

SPOT 150 / SPOT 175

Strahler mit Minimaldesign, die sich in jede Umgebung integrieren. Mit verschiedenen Winkel- und Leistungsoptionen.

Projectors with minimal design which can be integrated into all aesthetics and with different angle and power options.



Integriertes Potentiometer zur individuellen Helligkeitsregelung der einzelnen Leuchten.

On-board potentiometer for individual intensity control for each luminaire.

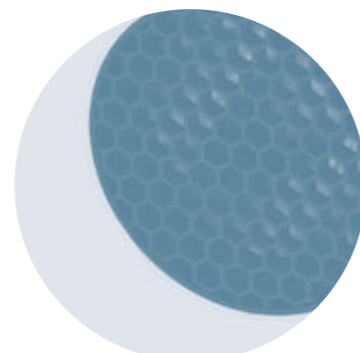

Abschirmzubehör für alle Strahler.

Shielding accessories available for all projectors.



SPOT 175 LENS

Strahler mit bifokaler Dual-Optik, mit der sich der Winkel zwischen 13° und 56° verstellen lässt.

Projector with adjustable double bifocal lenses, which allows angle adjustment from 13 to 56 degrees.

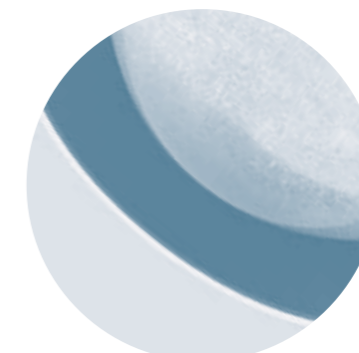

Verstellbare Bifokaloptik mit Abschirmring.

Adjustable bifocal lenses with shielding ring.



WALL WASHER

Neuer Wandfluter, der dank seines von FLOS entwickelten Reflektors nicht nur eine kompakte Bauweise sondern auch eine hervorragende Lichthomogenität bietet.

New wall washer which, thanks to its reflector designed by FLOS, offers an extra compact size together with impeccable levels of light homogeneity.

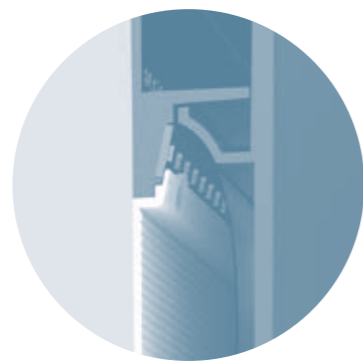

Auflichtlampe für maximalen Sehkomfort und Lichthomogenität.

Back projection light source for maximum visual comfort and homogeneity.



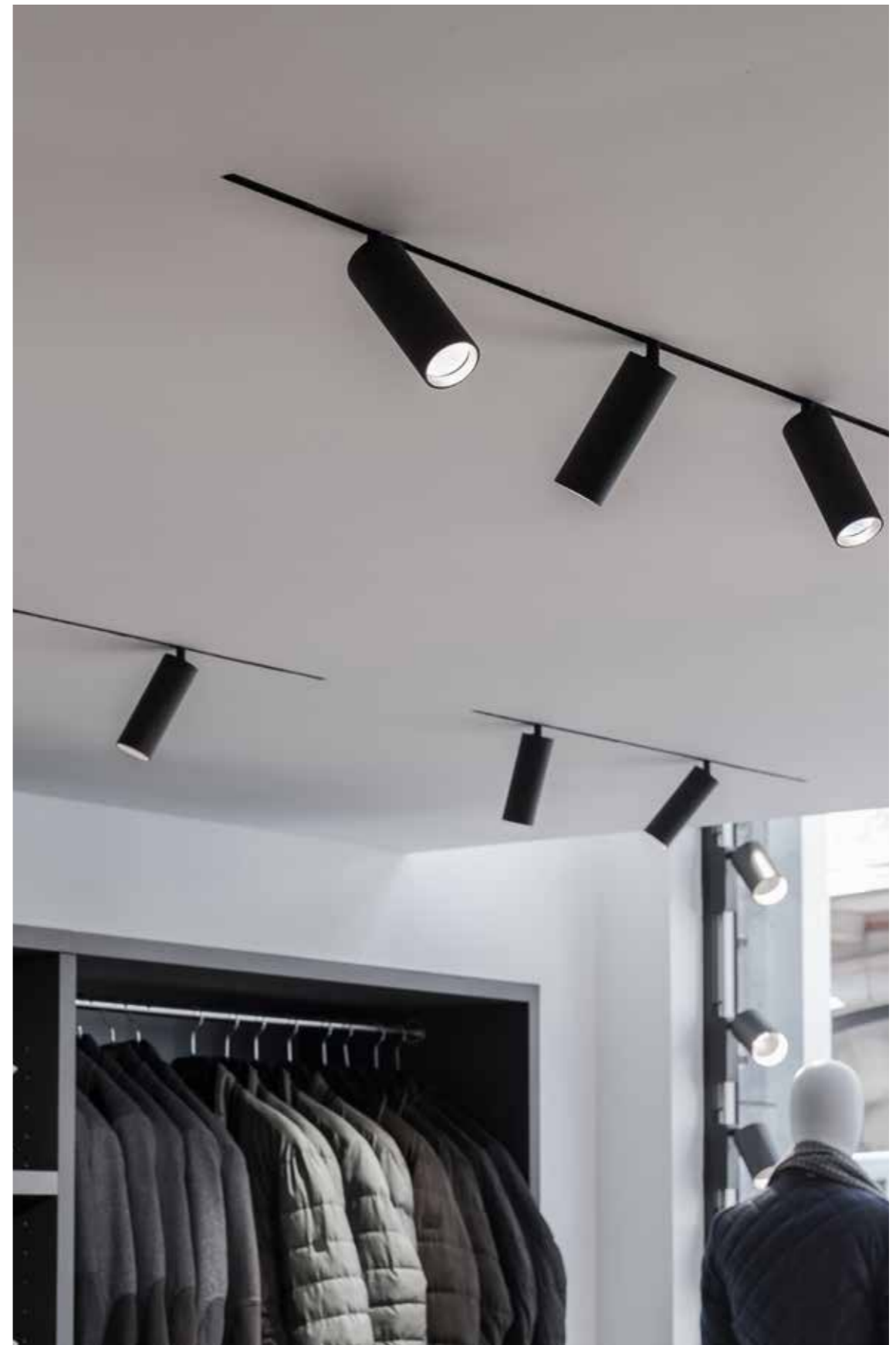



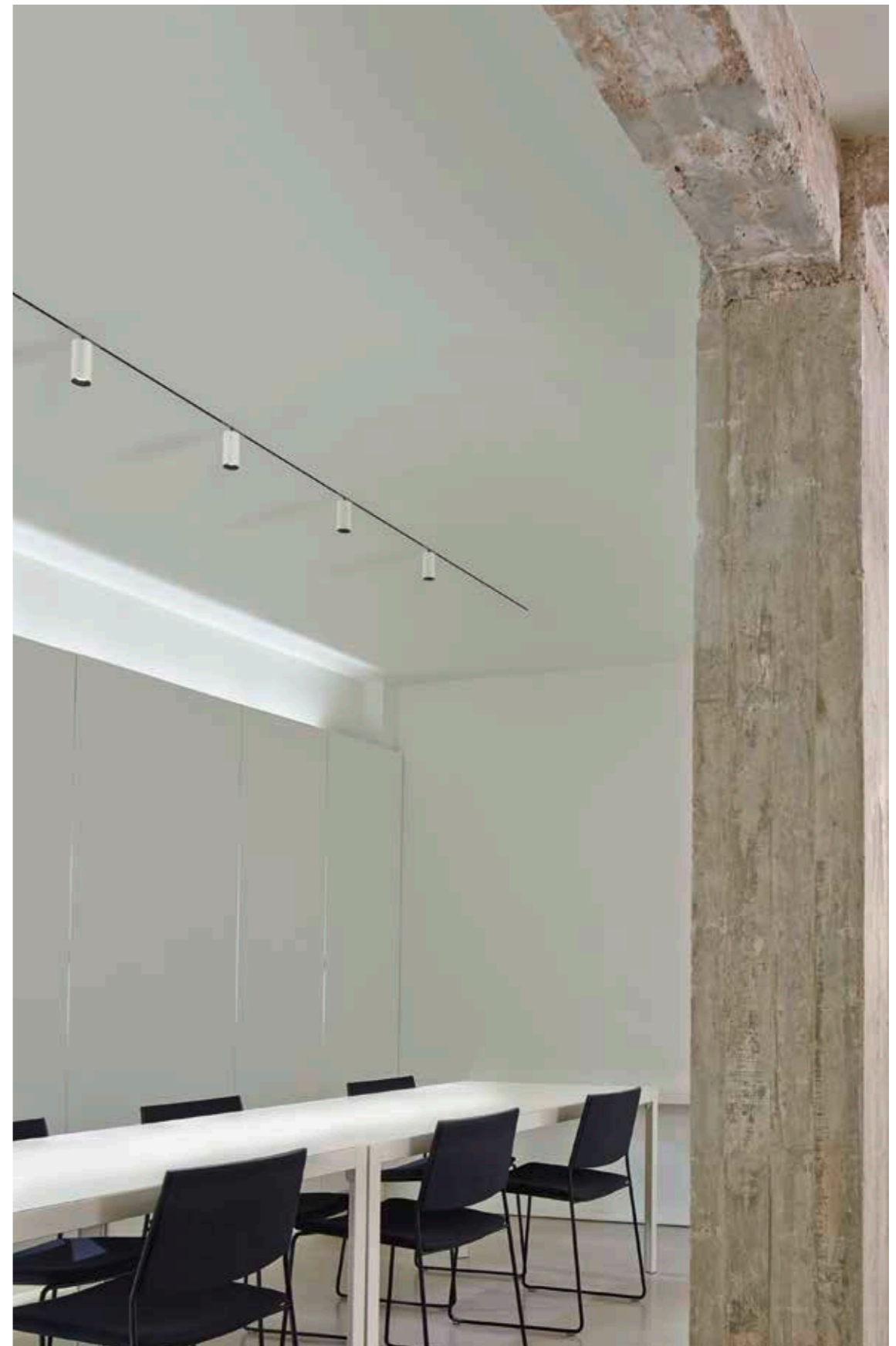
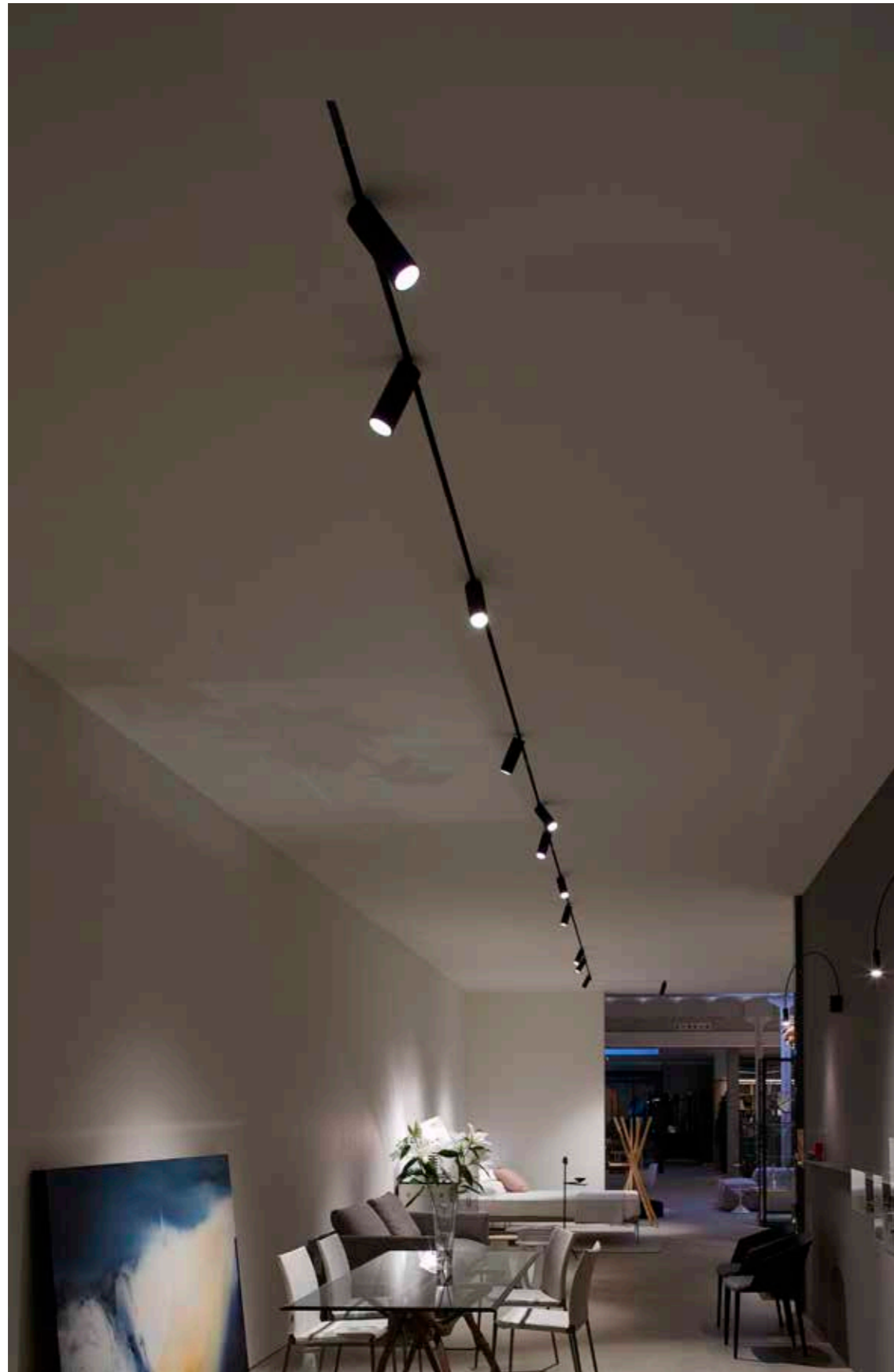



LIGHT MODULES - TRACKING POWER INSTALLATION

UT PRO 150



LED ARRAY
23,5W

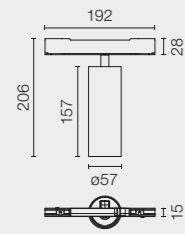

UT PRO 175



LED ARRAY
35,3W

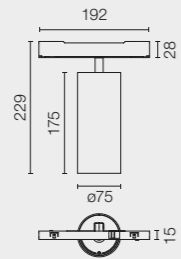

UT PRO 175
LENS



LED ARRAY
35,3W

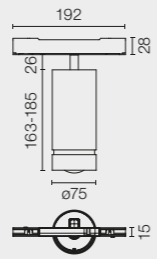

UT PRO
WALL-WASHER



TOP LED
25,5W

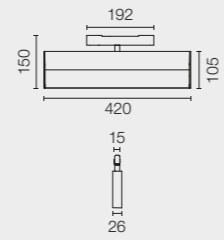

RECESSED



■ 14 Schwarz
14 Black

SURFACE



□ 40 Weiss
40 White ■ 14 Schwarz
14 Black

LIGHT MODULES - UNIVERSAL INSTALLATION

UT PRO 150
GA-69



LED ARRAY
23,5W

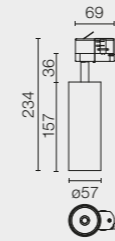

UT PRO 175
GA-69



LED ARRAY
35,3W

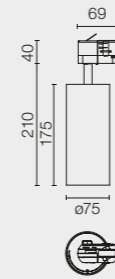

UT PRO 175
LENS GA-69



LED ARRAY
35,3W

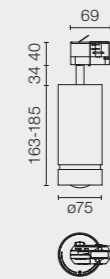

UT PRO
WALL-WASHER
GA-69
(DALI GA-600)



TOP LED
25,5W

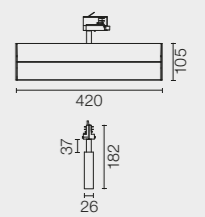

Spot



Medium



Flood



Wall-Washer

In die Architektur integriertes Struktursystem für die Installation von Anlagen sowohl für direkte als auch für indirekte Beleuchtung. Das System Light Cut Mini kann mit den neuesten LED-Strahlern sowie mit Halogenstrahlern oder Halogen-Metaldampfstrahlern ausgestattet werden. Die Allgemeinbeleuchtung ist mit Leuchtstoff, LED und RGB LED erhältlich.

LIGHT CUT MINI

A structural system integrated into the architecture, which permits mounting direct and indirect lighting gear. The Light Cut Mini system can be equipped with latest generation LED spotlights, halogen spotlights or metal halide spotlights. The ambient lighting is available in fluorescent, LED and in RGB LED lamps.







Einfache Installation der Strahler im Profil ohne spezielle Werkzeuge. Das Befestigungssystem ermöglicht einfachen Positionswechsel und Hinzufügen weiterer Strahler.

Easy installation of spotlights on profile without the need for specific tools. The position of the spotlights can easily be changed or more added with this fixture system.

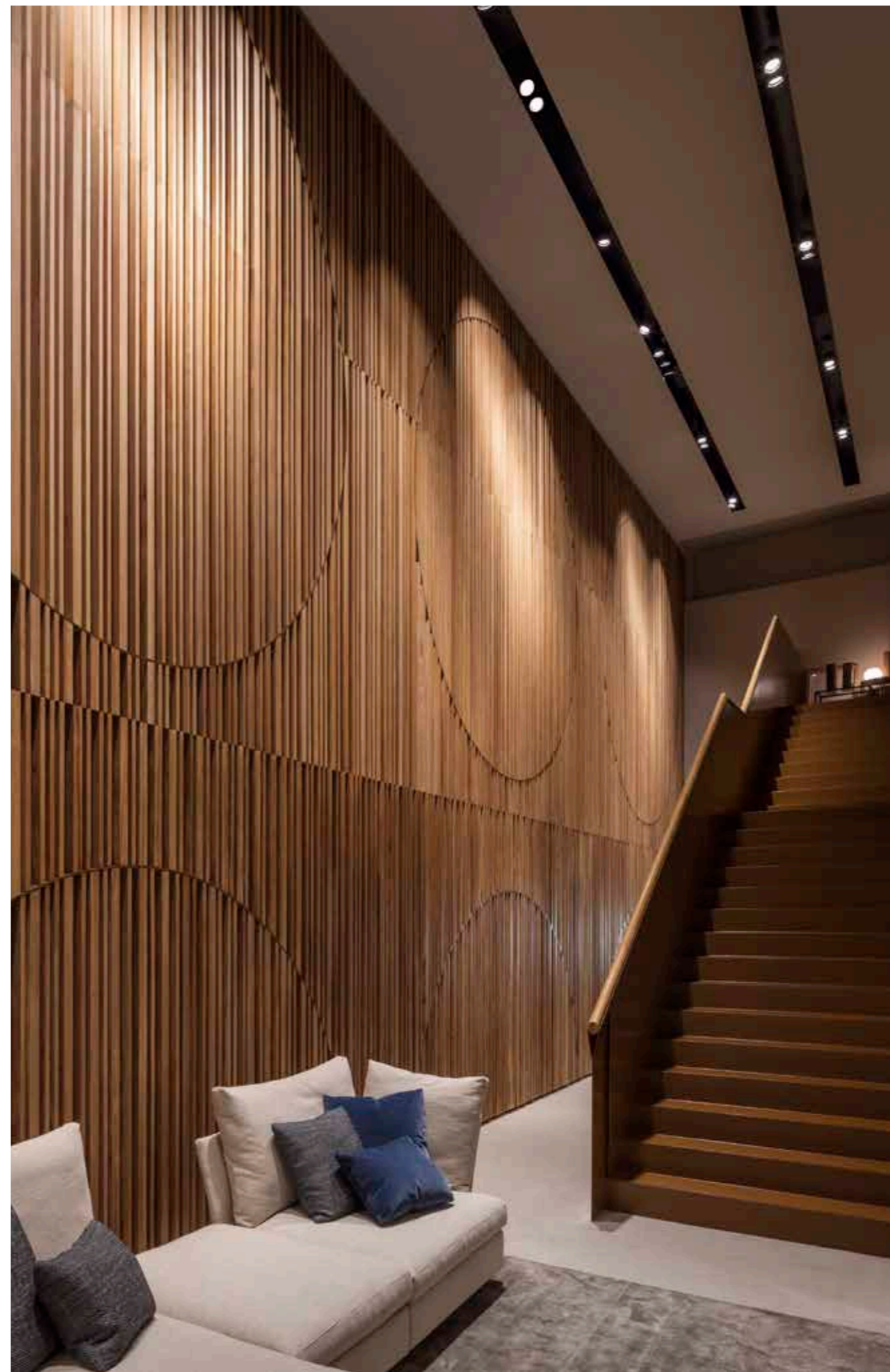

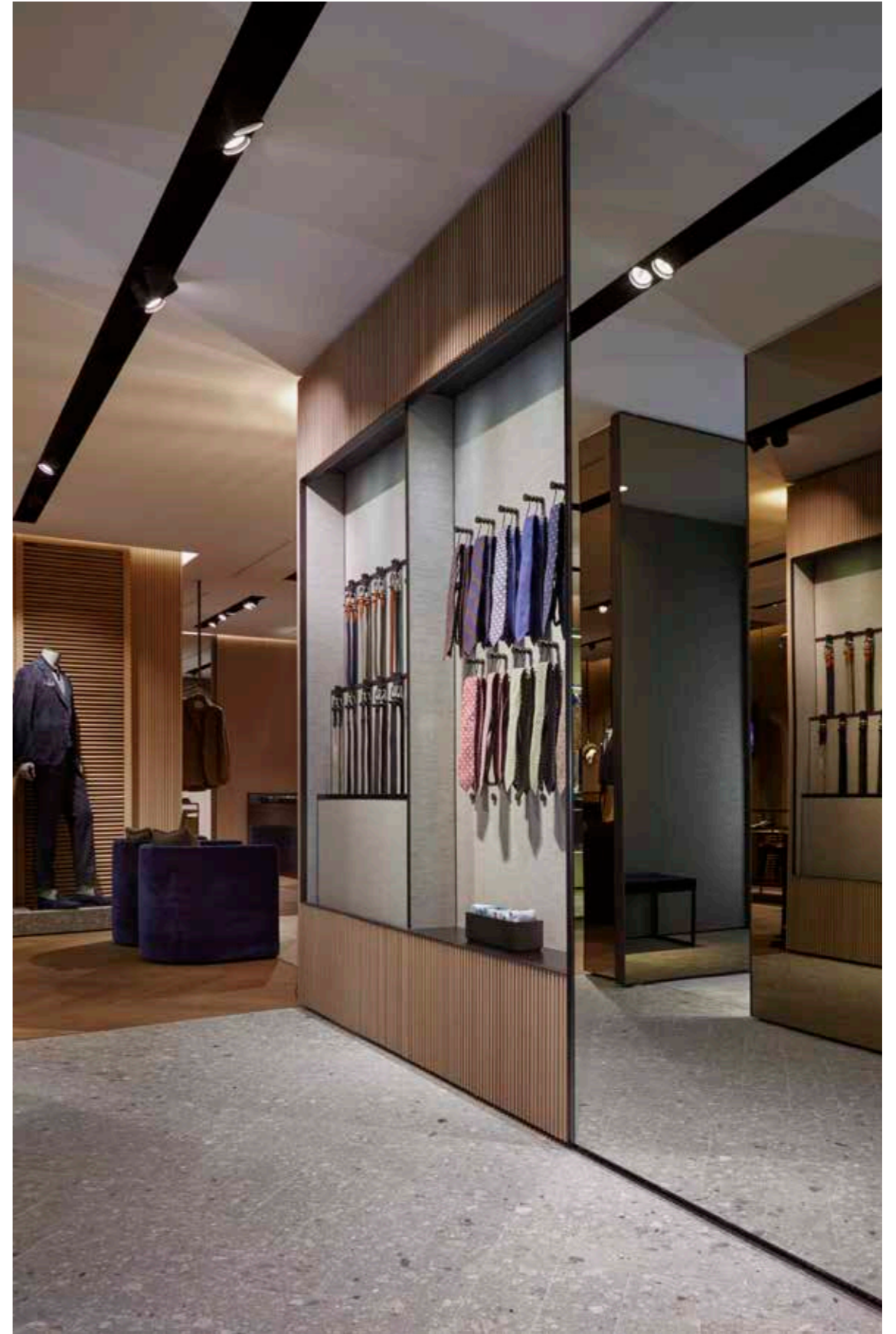



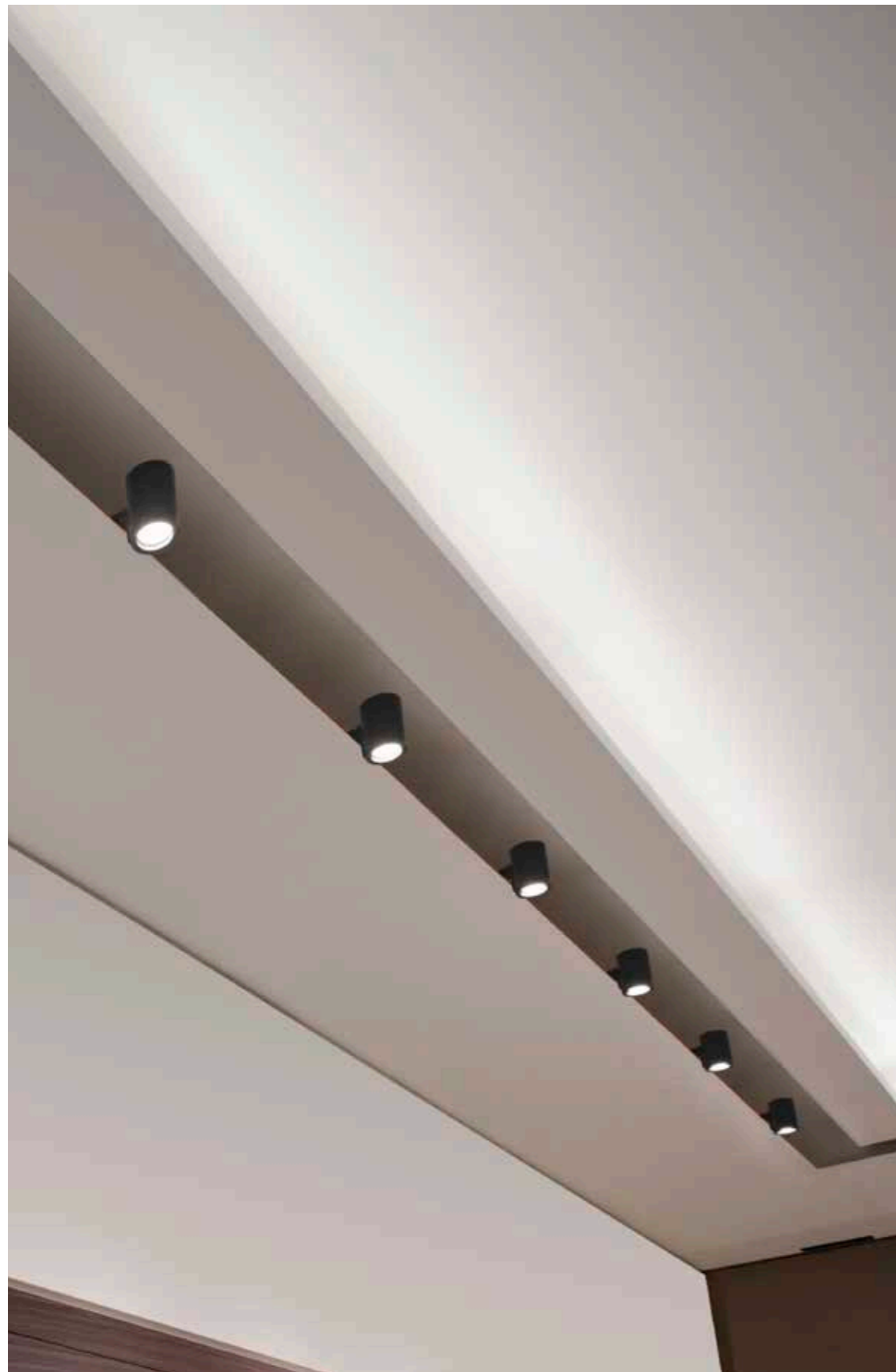

SPOT MODULES



LED ARRAY
14,4W

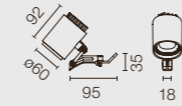

POWER LED
10W

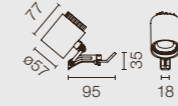

PHOSPHOR LED
17W
18W

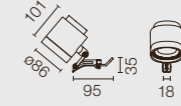

QR-CBC 51
max 50W
- OR -
LED QR-CBC 51
7/10W

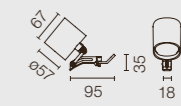

Spot



Flood



Wide Flood

□ 30 Mattweiss
30 Matt White

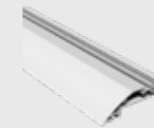

■ 14 Mattschwarz
14 Matt Black

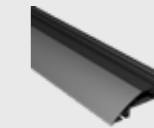

Moonline bringt Ihnen eine revolutionäre Beleuchtungstechnologie näher. Die schlanke und reine Lichtlinie bietet jedem Architekten technologischen sowie absolut formalistischen Beleuchtungskomfort. Die Strip Lights fügen sich perfekt in den Architekturraum ein und betonen das architektonische Design. Voll in die Architektur integrierte Beleuchtung ist Wirklichkeit geworden. Moonline bietet neue Beleuchtungskultur mit bisher unvorstellbaren visuellen Möglichkeiten. Die Smart Technology steht für nachhaltige Entwicklung: die offenen Strukturprofile lassen sich problemlos in alle Oberflächen einfügen und der Austausch der LED-Module erfolgt blitzschnell mit einem raffinierten magnetischen Stecksystem. Eine Mindesteinbautiefe von nur 5cm ist ausreichend. Die praktisch endlosen, dreidimensionalen Verbindungsmöglichkeiten bieten Ihren kreativen Vorstellungen ungeahnte Freiheit.

MOONLINE

With Moonline a revolutionary lighting technology beckons you. The slim and clean light line offers both technological and very formalistic light comfort. The strip lights fall perfectly, and together with the architecture, enhances the architectural design. With Moonline a fully integrated Architectural Lighting is a true reality offering unprecedented and numerous visual possibilities. The smart technology is a reflection of a sustainable development and the structural open profiles allow themselves to be incorporated effortlessly into any surface requiring only a minimal depth of 5cm. The replacement of the LED modules occurs instantly with an ingenious magnet click system allowing endless three-dimensional coupling combinations to give an unprecedented freedom to your creative ambitions.







LIGHT STRIPE
125 mm



TOP LED
2,5W



125

LIGHT STRIPE
500 mm



TOP LED
10W



500

00 Grundierung
00 Primer

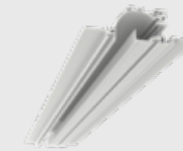

40 Weiss
40 White



Produktfamilie für die Installation mit leistungsstarker LED-Lichtquelle. Die Kollektionsfamilie besteht aus linearen LED-Streifen auf Mikroprofilen aus fließgepresstem Aluminium in unterschiedlicher Länge, die miteinander verbunden werden können. Diese Lichtmodule werden mit Akzent-Strahlern kombiniert, die in drei verschiedenen Optiken erhältlich sind.

LED SQUAD

Surface-mounted family with high performance LED light source. The collection is comprised of linear LED strips mounted on extruded aluminium micro-profiles of different lengths, which can be interconnected. These light modules are combined with accent spotlights available in three optics.



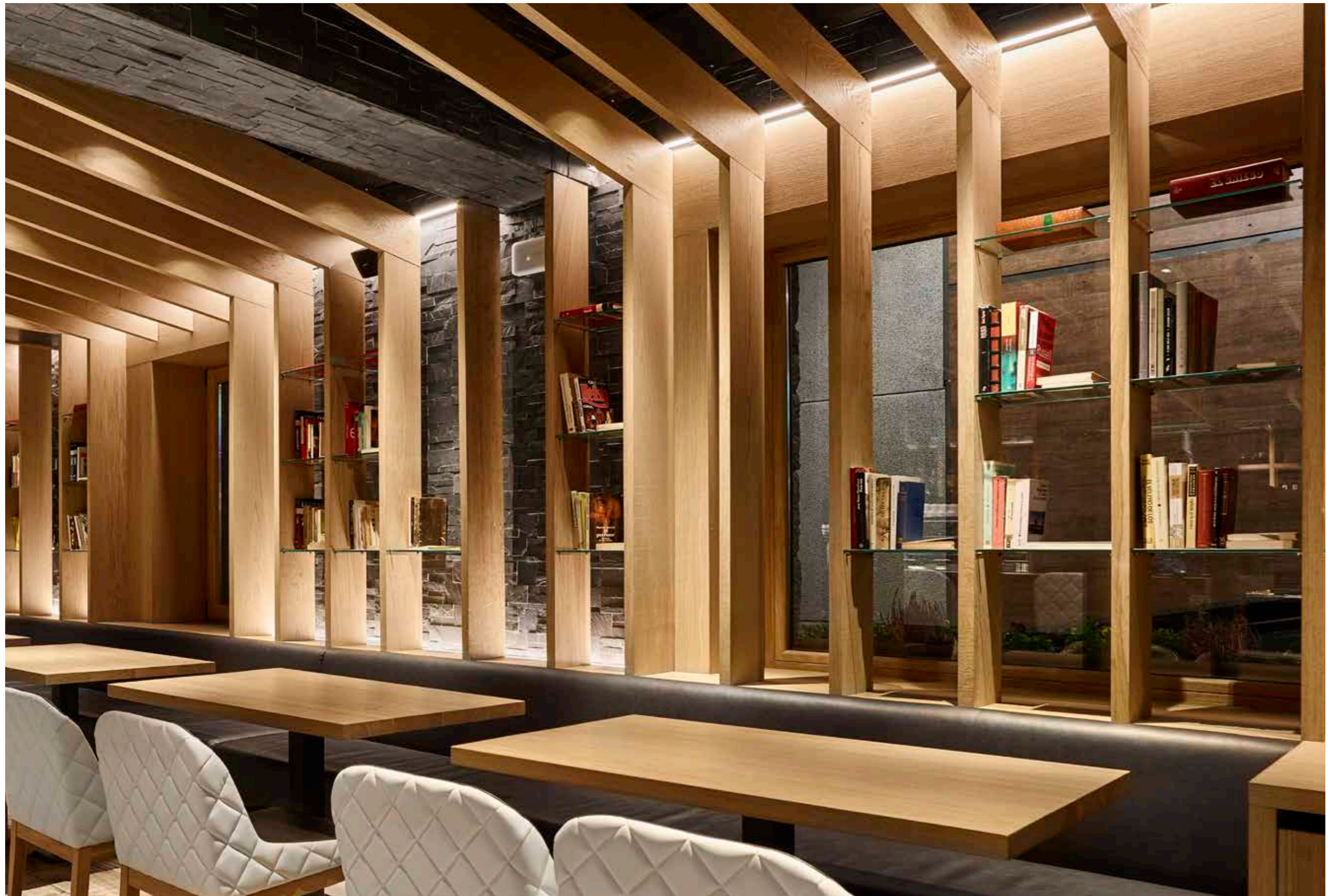



Besonders empfohlen für die Installation in Möbeln in Gewerberäumen und Wohnungen.

Especially recommended for installations in retail / residential fittings.

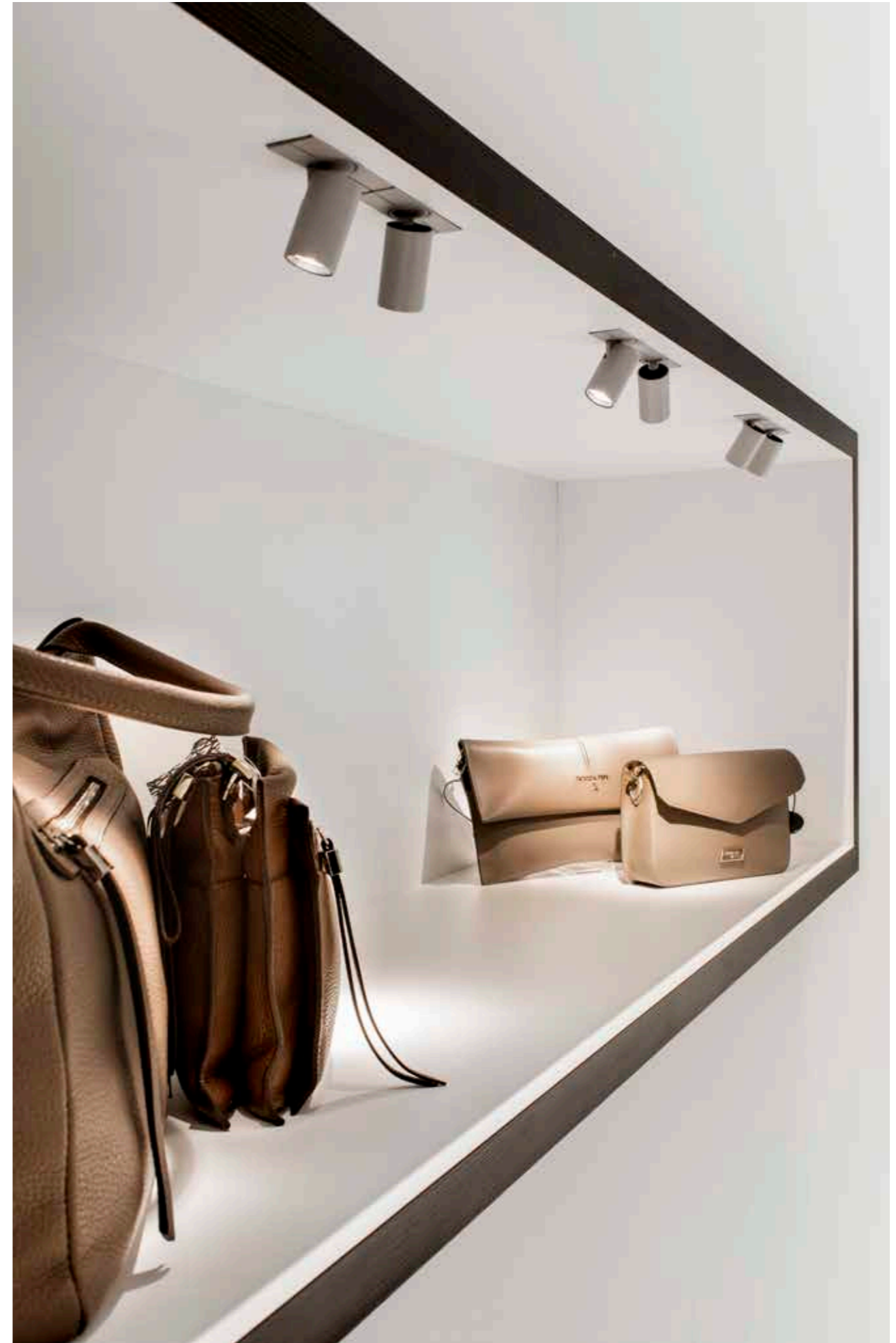



LED SQUAD

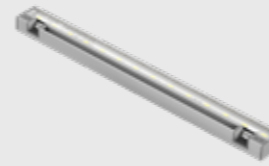

TOP LED



LED SQUAD
1 SPOT



POWER LED
4W

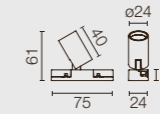

LED SQUAD
2 SPOTS

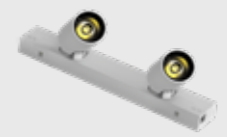

POWER LED
6W

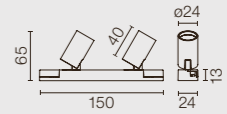

Spot



Medium



Flood

Led Squad

29 Eloxiertes Aluminium
29 Anodized Aluminium

AN Eloxiertes Schwarz
AN Anodized Black



Led Squad Spot

30 Weiss
30 White

02 Grau
02 Grey

14 Schwarz
14 Black



Das In-Finity LED-Beleuchtungssystem bietet Fachleuten, die eine Hauptbeleuchtung für Büroräume und öffentliche Flächen installieren möchten, geeignete Lösungen für jede Installationsart und ermöglicht Designs wie punktuelle Lichtquellen oder unendliche Lichtstreifen. In-Finity sorgt nicht nur für angenehme und energieeffiziente Beleuchtung, sondern bietet gleichzeitig höchste Qualität und eine ästhetische Optik. Dank der drei Profiltypen, der verschiedenen Montagearten (mit oder ohne Verkleidung, an der Wand, hängend) und der Möglichkeiten für diffuses oder punktuell Licht lassen sich unter Berücksichtigung der Umgebungsbedingungen sämtliche Projektanforderungen an das Design erfüllen.

IN-FINITY

For lighting professionals looking for the backbone of a lighting installation for an office or public space project, the In-Finity LED lighting system offers coherent solutions suitable for any kind of installation, with luminaires designed for use as a single light source or arranged in an infinite light line. In-Finity delivers visual comfort and energy efficiency, combining high performance with impeccable aesthetics and top quality construction. All project needs can be satisfied with combinations of the three profile widths, the various installation options (recessed trim and no trim, surface-mounted and suspended) and diffuse or concentrated glare-free light versions to meet ambient design requirements.





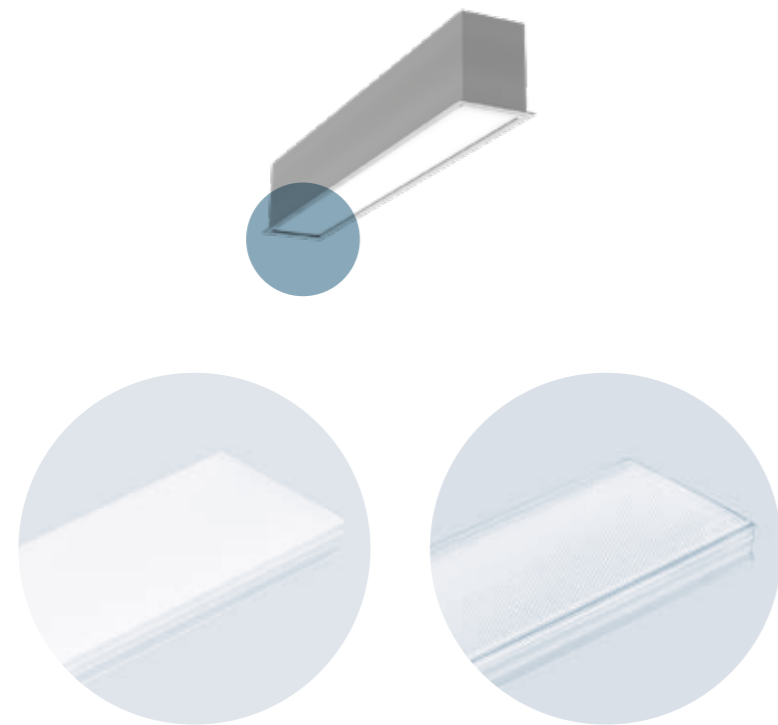

Opaldiffusor für eine gleichmäßige und blendfreie Raumbeleuchtung.

Opal diffuser for glare free and uniform lighting throughout the room.

Hochwirksamer Diffusor, der durch seine einzigartige, mehrlagige mikro-prismatische Struktur für eine blendfreie Beleuchtung im UGR<19 Winkel sorgt.

Highly efficient multilayer diffuser that, thanks to its unique micro-prismatic texture, provides a glare free UGR<19 light beam.

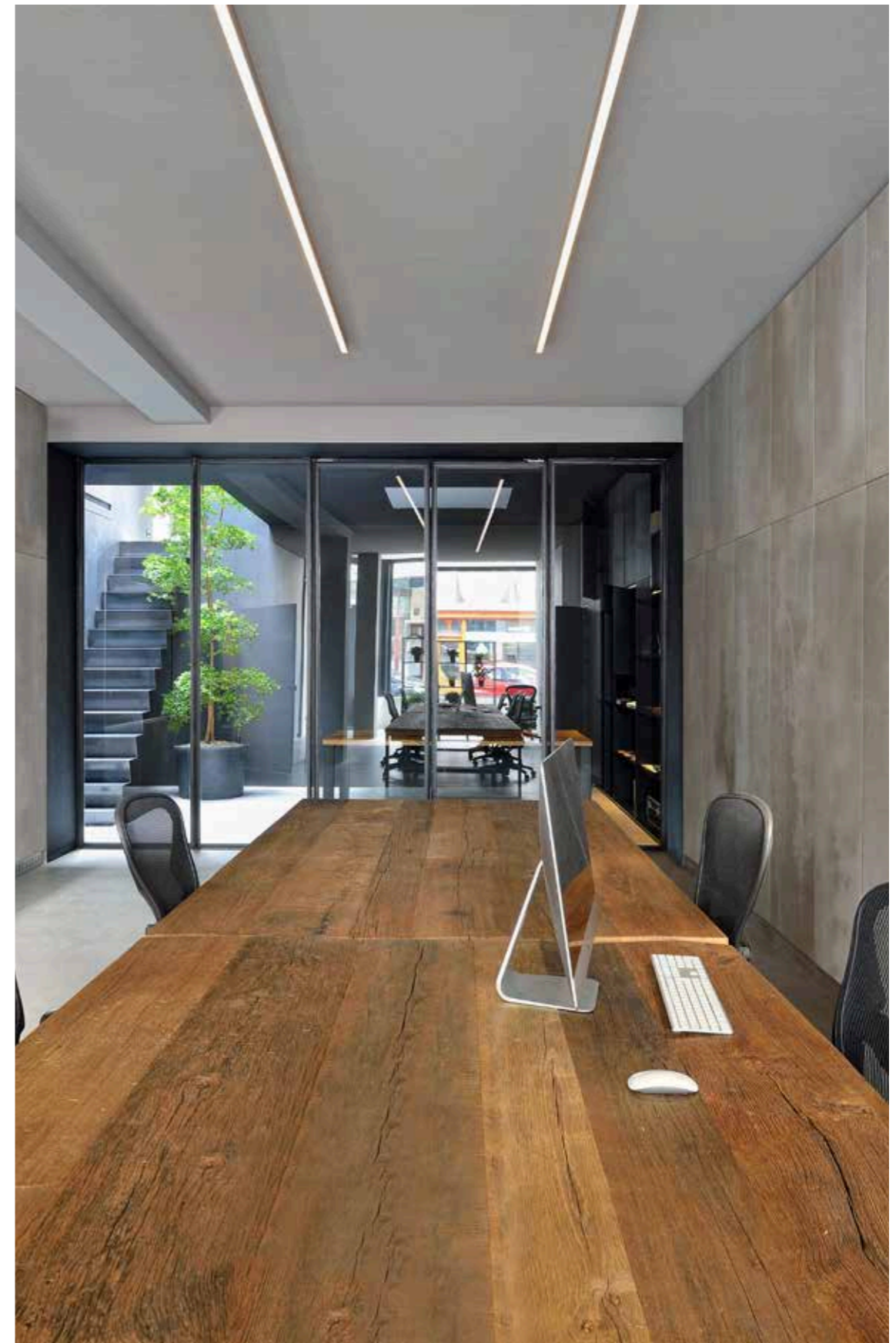

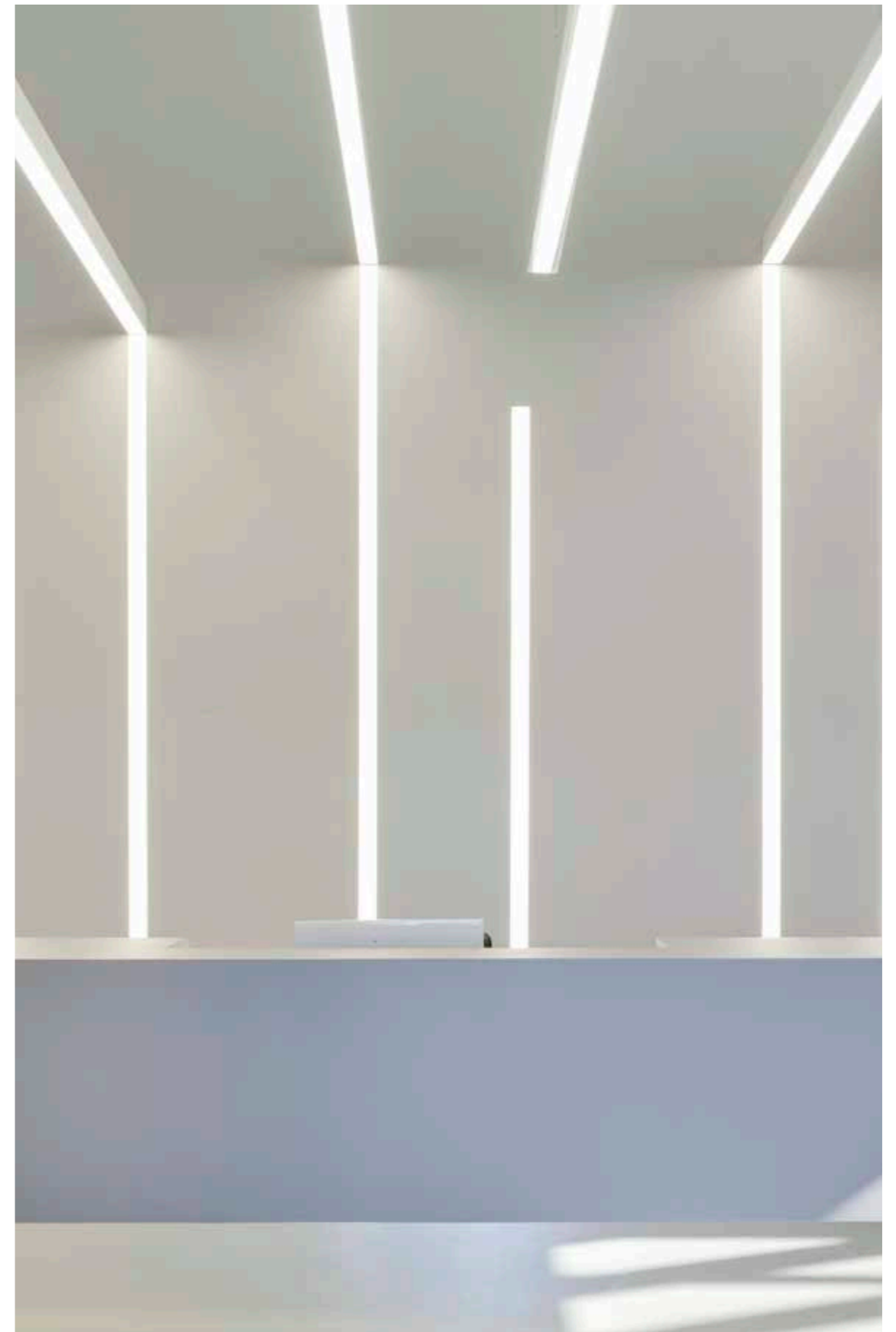
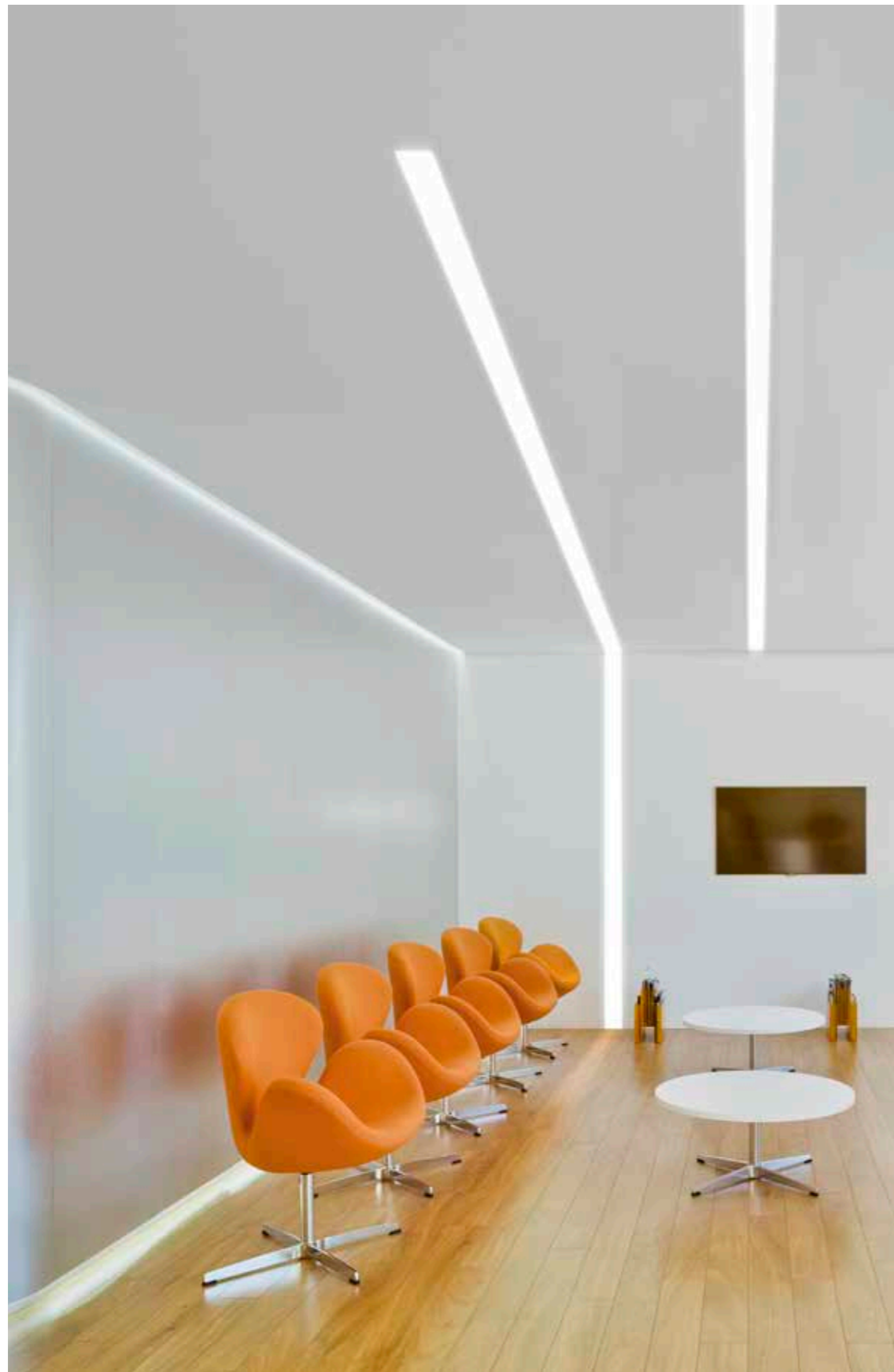



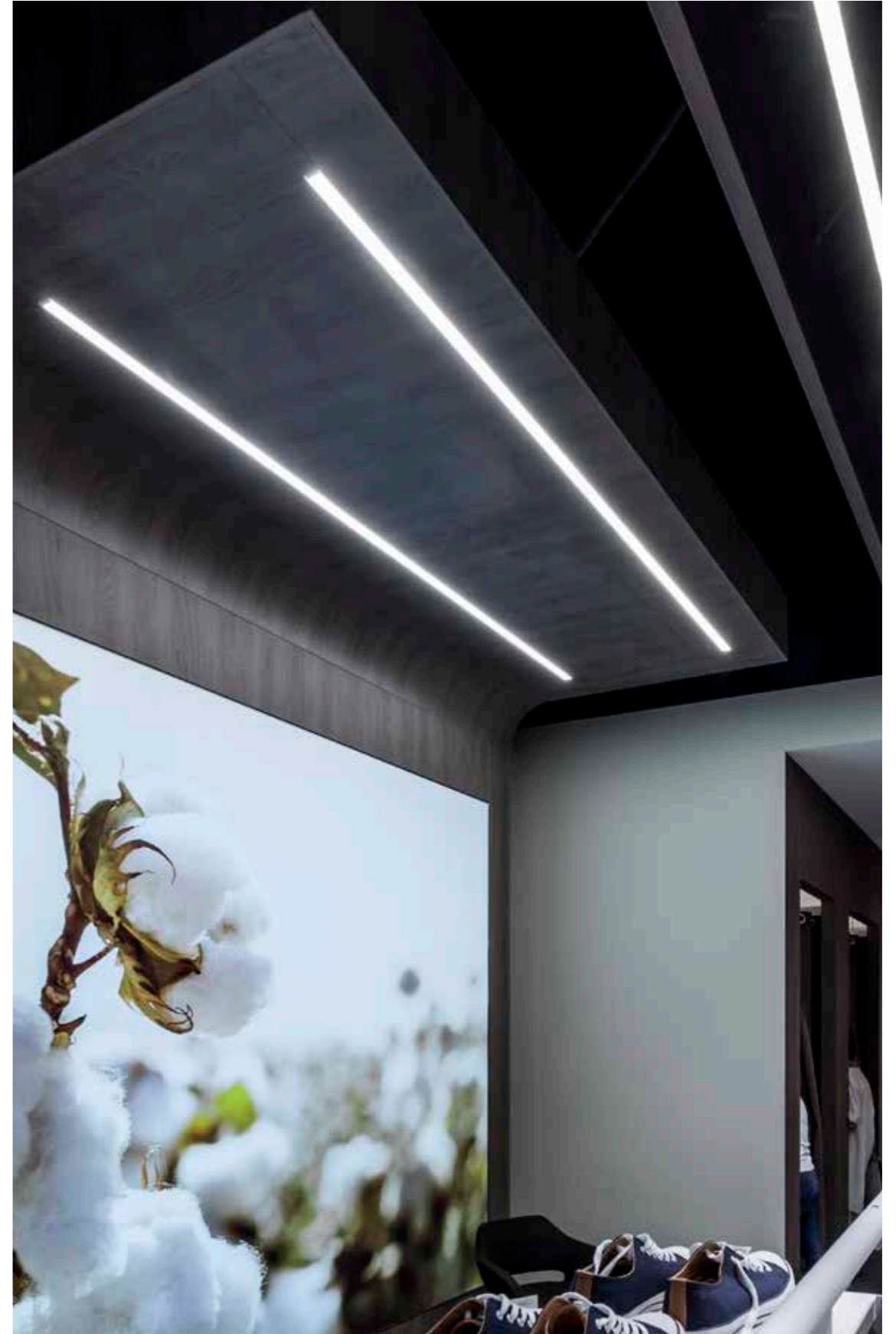



RECESSED
TRIM / NO TRIM

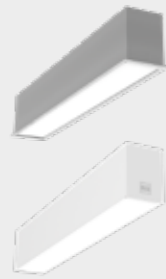

35 mm

TOP LED
19,8W/m

SURFACE

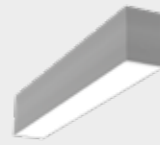

70 mm

TOP LED
23,1W/m

SUSPENSION
DOWN



100 mm

TOP LED
34,1W/m

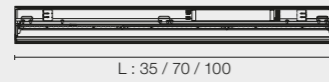

L : 35 / 70 / 100

TRIM

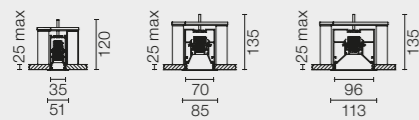

NO TRIM

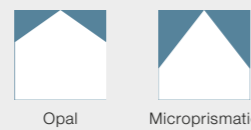
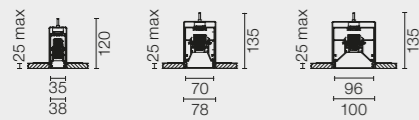

Opal

Microprismatic

SUSPENSION
UP&DOWN



35 mm

TOP LED
32,6W/m

70 mm

TOP LED
35,9W/m

100 mm

TOP LED
46,9W/m



L : 35 / 70 / 100

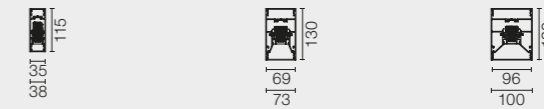

30 Weiss
30 White

02 Grau-eloxiert
02 Anodized Grey

14 Schwarz
14 Black





SUPER LINE

Leuchte von hohem technischem Niveau, effizient und dezent, bestehend aus einer Stange, die direktes und indirektes Licht miteinander kombiniert. Die Leuchte wird von zwei nicht sichtbaren Koaxialkabeln gehalten, die als Aufhängung dienen und gleichzeitig die Stromkabel beherbergen. Perfekt geeignet für Büroräume oder andere Räumlichkeiten, in denen sowohl hohe Lichtleistung als auch großer Komfort gefordert sind.

SUPER LINE

High-tech, efficient and delicate luminaire, comprised of a rail combining direct and indirect light, secured by two invisible coaxial cables, serving both as anchorage and electrical wiring. Perfect in offices or places where a high light efficiency and comfort are needed.

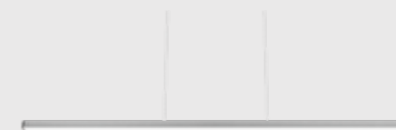

DESIGNED BY FLOS ARCHITECTURAL





SUPER LINE

Super Line ist mit einem mehrschichtigen technischen Diffusionsfilter ausgestattet, der für eine perfekte Lichtverteilung sorgt und den optischen Effekt und den Sehkomfort verbessert.

Super Line PRO ist mit einem schwarzen Raster ausgestattet, das eine vollständige Kontrolle der Lichtverteilung und maximalen Komfort in Arbeitsumgebungen gewährleistet.

Super Line und Super Line PRO Up & Down sind in zwei Versionen verfügbar:

- Indirekt: eine Version, die die indirekte Emission nach oben begünstigt und entworfen wurde, um ein UGR <19 und die strengsten Lichtbedingungen anzubieten.
- Direkt: eine Version, die die direkte Beleuchtung begünstigt und die Effizienz maximiert, gleichzeitig aber den "Höhleeffekt" mit seiner indirekten Intensität verhindert und so ein hohes Maß an Komfort garantiert.

SUPER LINE PRO

Super Line is equipped with a technical multi-layer diffuser filter that guarantees perfect light distribution and improves the optical effect and visual comfort. Super Line PRO is fitted with a black raster that ensures total control of the light distribution and maximum comfort in work environments.

Super Line and Super Line PRO Up & Down are available in two versions:

- Indirect: version that favours indirect emission upwards, designed to offer a UGR<19 and the more specific lighting conditions required.
- Direct: Version that gives direct light and maximises efficiency, while at the same time preventing the "cave effect" with its indirect intensity that ensures a high level of comfort.

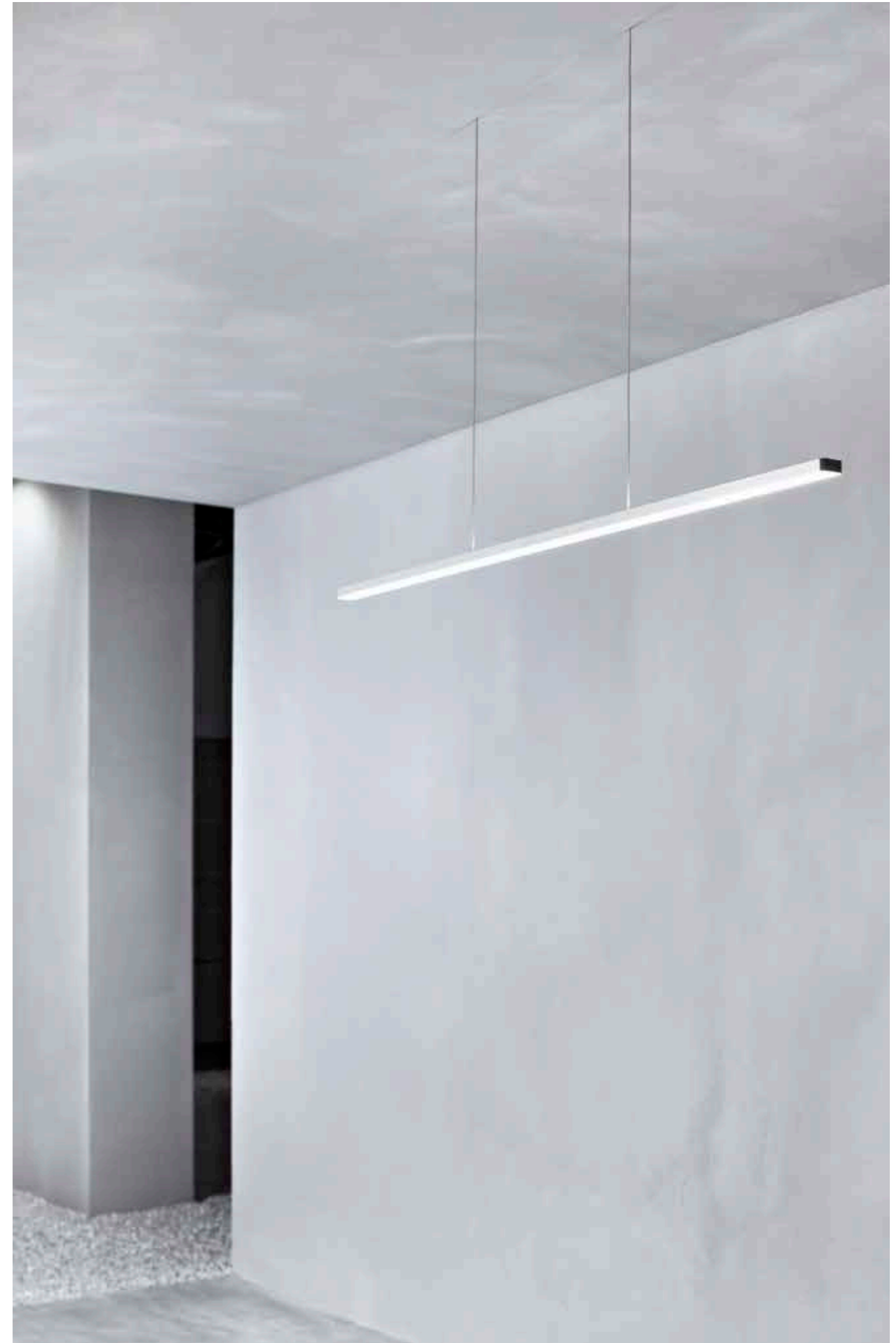





Trotz seiner extrem kompakten Abmessungen und der Nähe der LED-Punkte zum Diffusor wird eine gleichmäßige Lichtverteilung erzielt. Die LED-Punkte sind nicht sichtbar.

Although its dimensions are extra compact and the LED tips are close to the diffuser, it offers homogeneous light distribution. The LED tips are not visible.

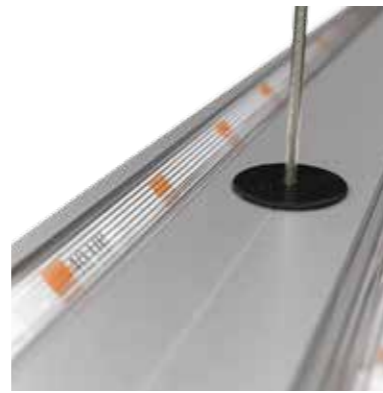

Detailansicht des Koaxialkabels, das die elektrische Verbindung herstellt und gleichzeitig als Aufhängung dient.

Detail of the coaxial cable that forms the electrical connection and can also be used for suspending.



Blende für die Installation mit dem Fernsteuergerät.

Embellishment for installation with remote equipment.





SUPER LINE
UP&DOWN
INDIRECT



SUPER LINE PRO
UP&DOWN
INDIRECT



TOP LED
58W

SUPER LINE
UP&DOWN
DIRECT



SUPER LINE PRO
UP&DOWN
DIRECT



TOP LED
58W

SUPER LINE
DOWN

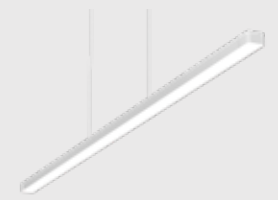

SUPER LINE PRO
DOWN

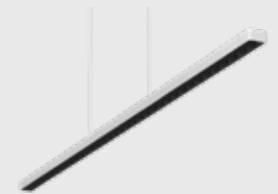

TOP LED
38,6W

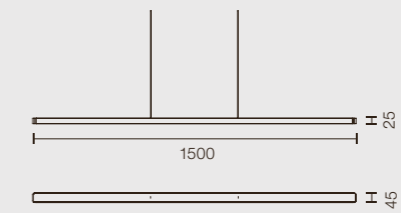

□ 30 Weiss
30 White

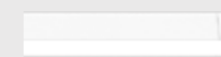

■ 02 Grau
02 Grey



■ 14 Schwarz
14 Black

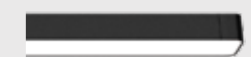

SUPER FLAT

Leuchtenfamilie für die allgemeine Beleuchtung (minimaler Impact dank kleinem Profil) mit direkter und indirekter Lichtverteilung. Ausgestattet mit LED-Lichtquellen für optimalen Lichtstrom und hohen Sehkomfort sowie minimalen Energieverlust. Die Familie Super Flat ist als Aufbau- und als Hängeleuchte erhältlich.

SUPER FLAT

Family of general lighting luminaires (minimal visual impact thanks to their reduced profile) with direct and indirect light distribution. Equipped with LED lighting sources that supply an optimal flow of light, great visual comfort and minimising energy losses. The Super Flat family is available in two different versions: surface and suspended.



DESIGNED BY FLOS ARCHITECTURAL





Reduziertes Aluminiumprofil zur Minimierung des Visual Impact.

Reduced size aluminium profile minimising visual impact.

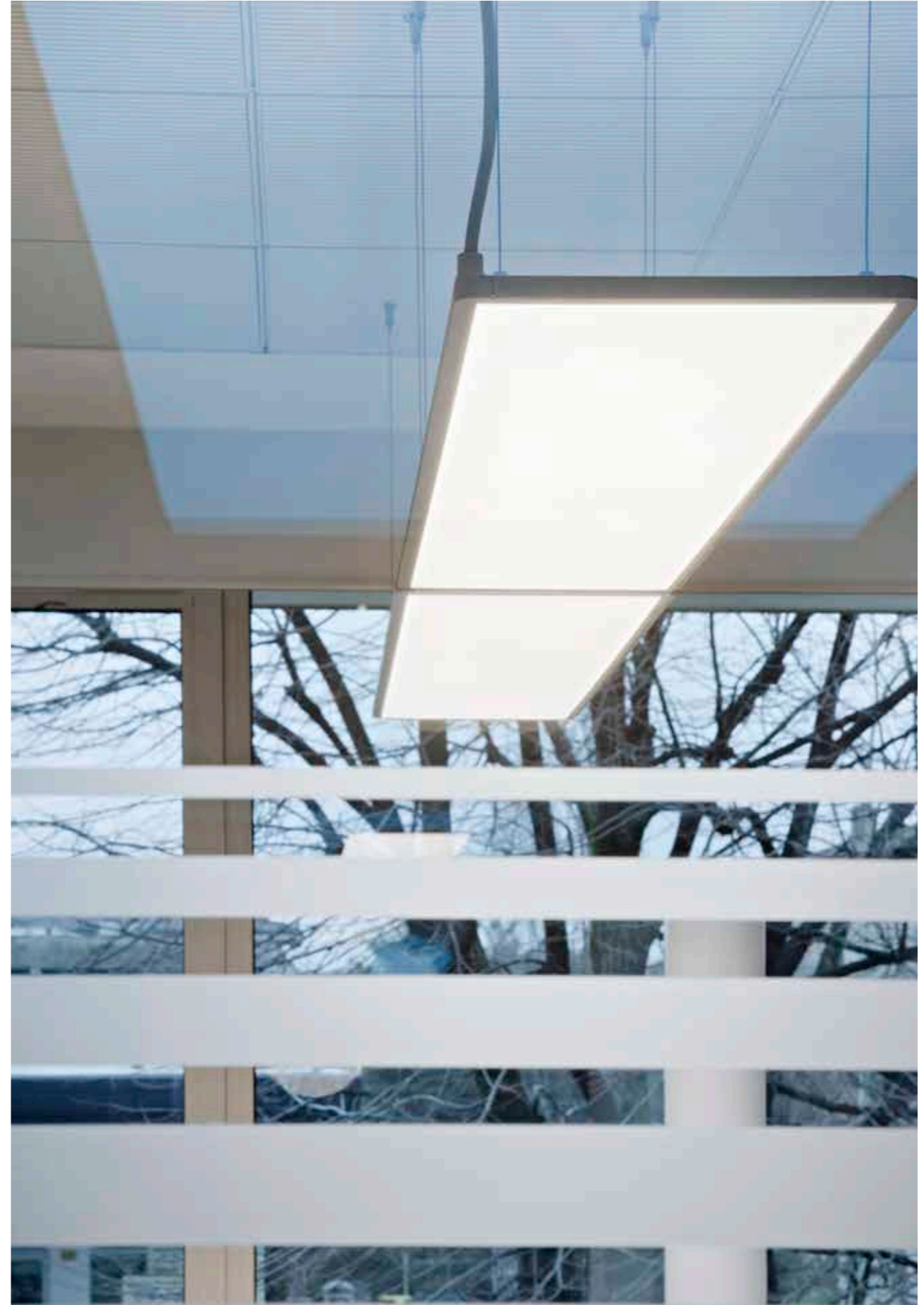

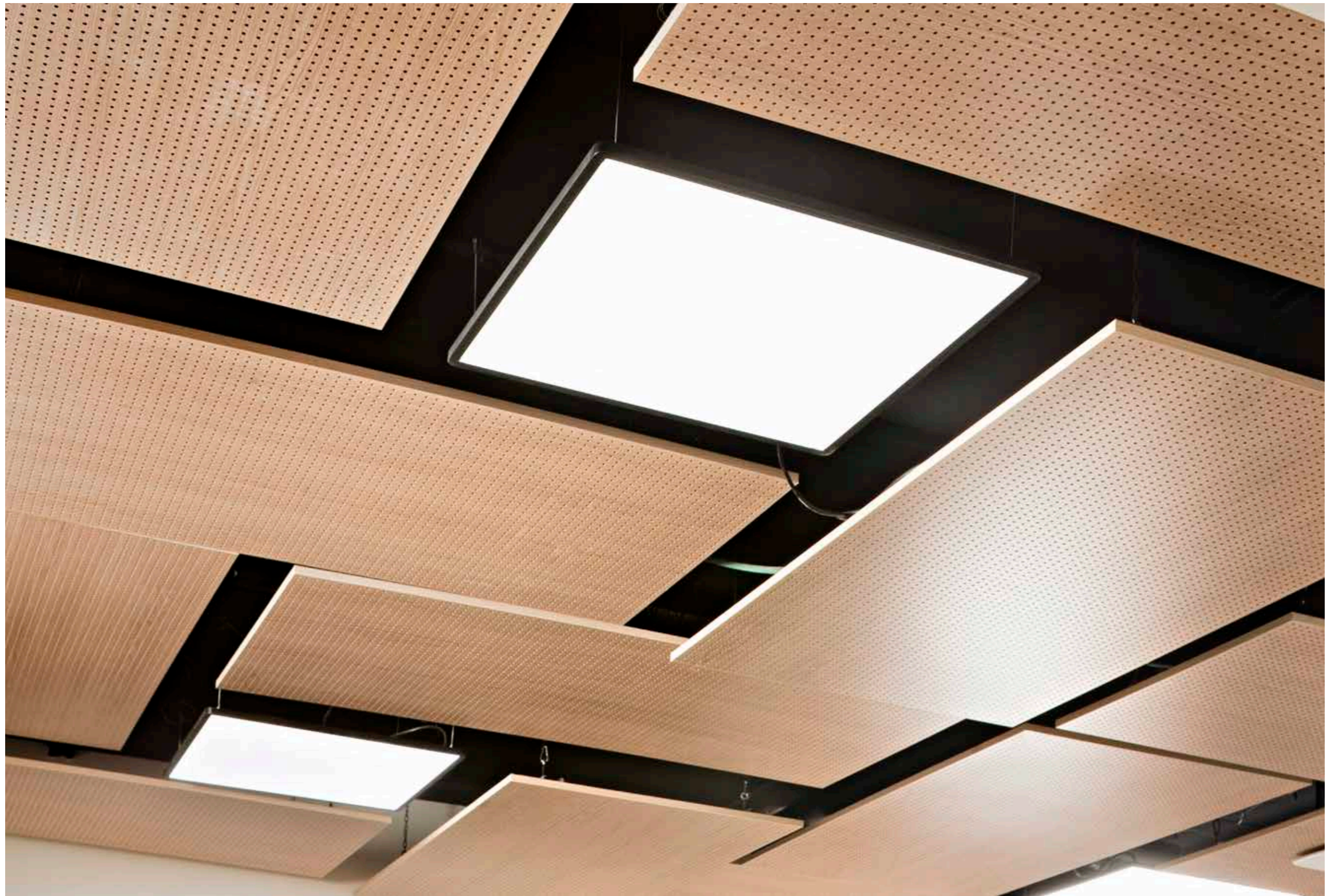

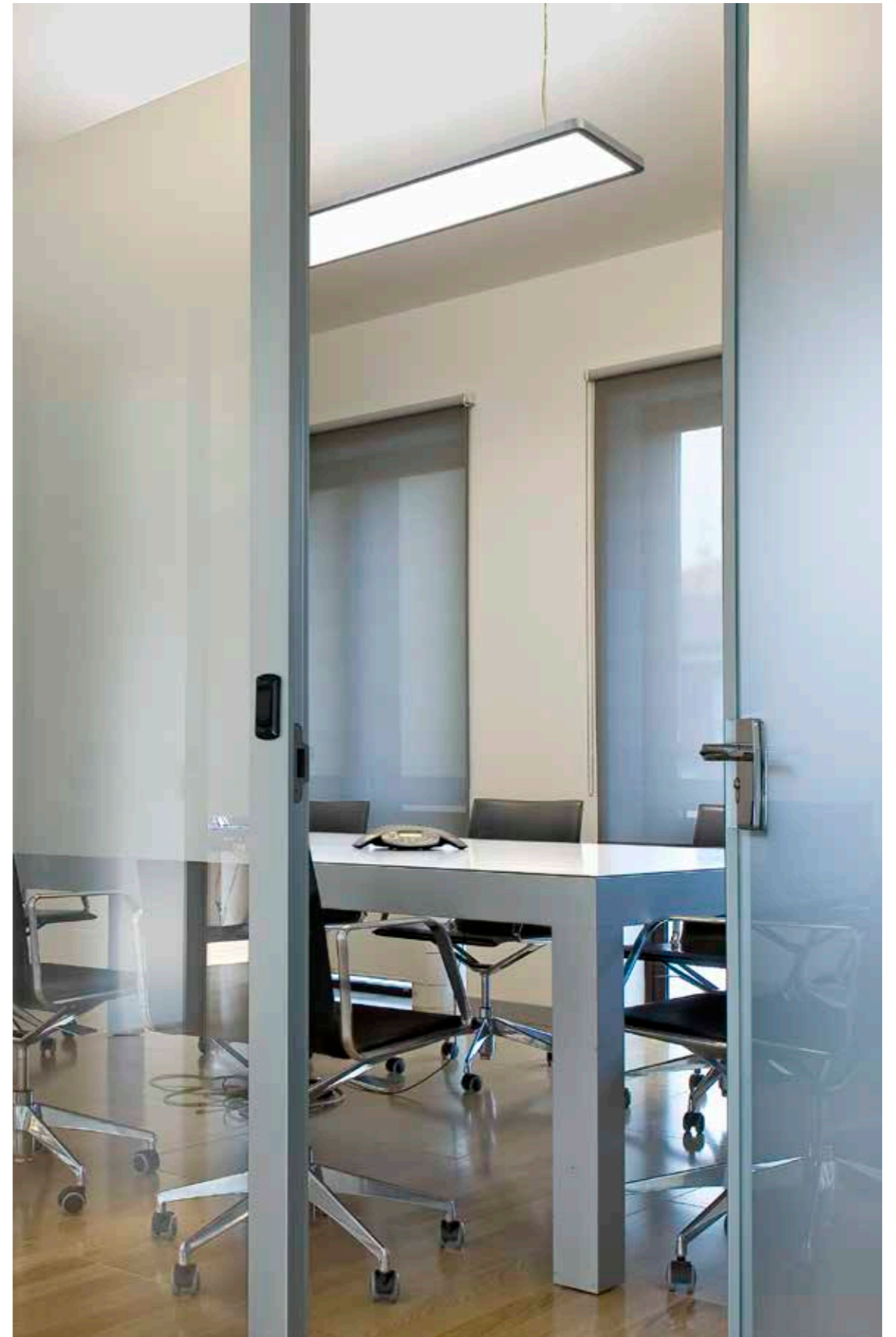





SUSPENSION
DOWN / UP&DOWN

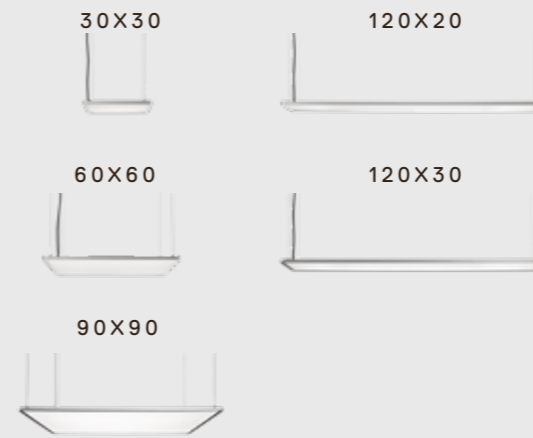

SURFACE

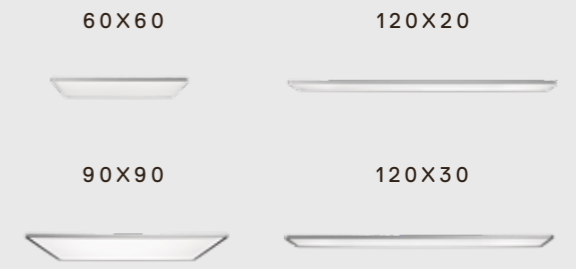

TOP LED

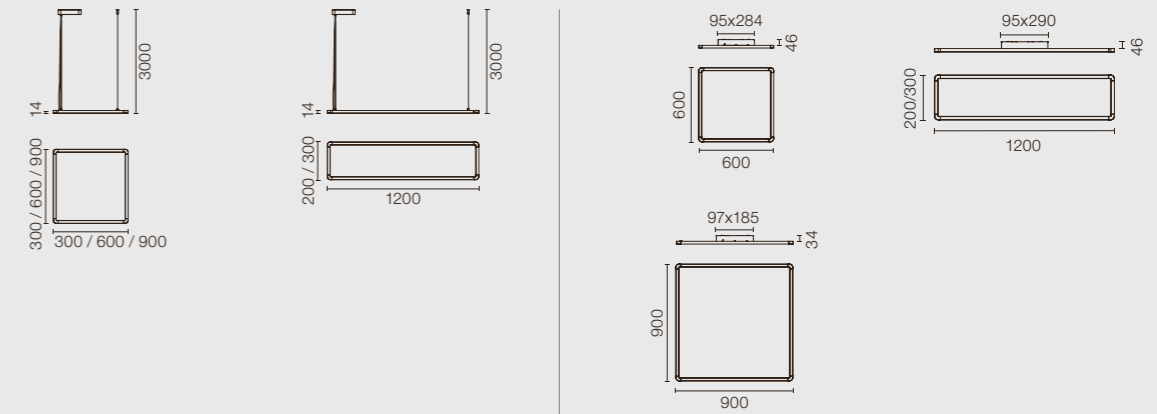

□ 30 Weiss
30 White

■ 02 Grau
02 Grey

■ 14 Schwarz
14 Black



reddot design award
winner 2013



LIGHT BELL

Hängeleuchte für die allgemeine Beleuchtung von Innenräumen. Hocheffiziente LED-Lichtquelle jüngster Generation und thermoplastischer Diffusor für geringen Energieverlust. Der Leuchtenreflektor ist aus präzisionsgedrücktem Aluminium gefertigt und in verschiedenen Farbkombinationen, sowohl innen als auch aussen, erhältlich und in durchsichtigem Glas.

LIGHT BELL

Suspended general lighting luminaire for indoor mounting. It has a high efficiency, latest generation LED light source and a low-loss technical thermoplastic diffuser. The luminaire reflector is made of spun aluminium, available in different patterns inside as well as outside and in transparent glass.



DESIGNED BY PIERO LISSONI





Austauschbarer Schirm in verschiedenen Verarbeitungen.

Interchangeable screen in different finishes.



Leistungsstarker Kühlkörper aus Aluminium zur sicheren Kühlung des LED.

High-performance aluminium dissipater that guarantees LED cooling.

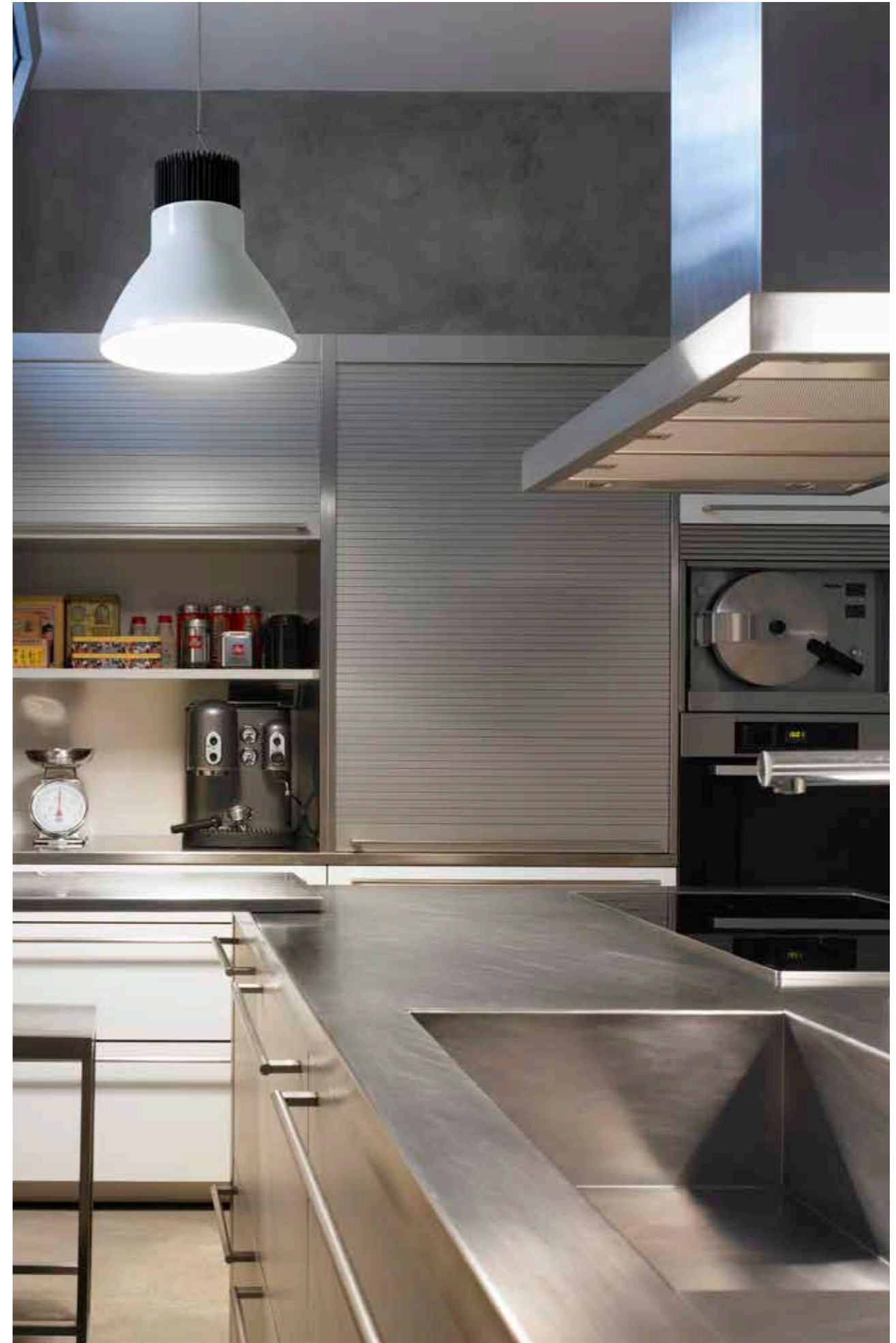



LIGHT BELL



LIGHT BELL



Außen / Outside 70 Mattweiss
70 Matt White AP Hochglänzendes Aluminium
AP Polished Aluminium AN Eloxiertes Schwarz
AN Anodized Black

Innen / Inside Eloxiertes Aluminium
Anodized Aluminium Eloxiertes Aluminium
Anodized Aluminium Gold
Gold



Außen / Outside MM Dunkelbraun
MM Dark Brown 7C Mattschwarz
7C Matt Black

Innen / Inside Gold
Gold Galvanisiertes Kupfer
Galvanic Copper

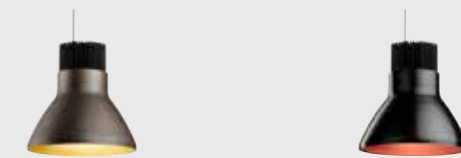

Außen / Outside 76 Glas Transparent
76 Transparent Glass CE Zement
CE Concrete



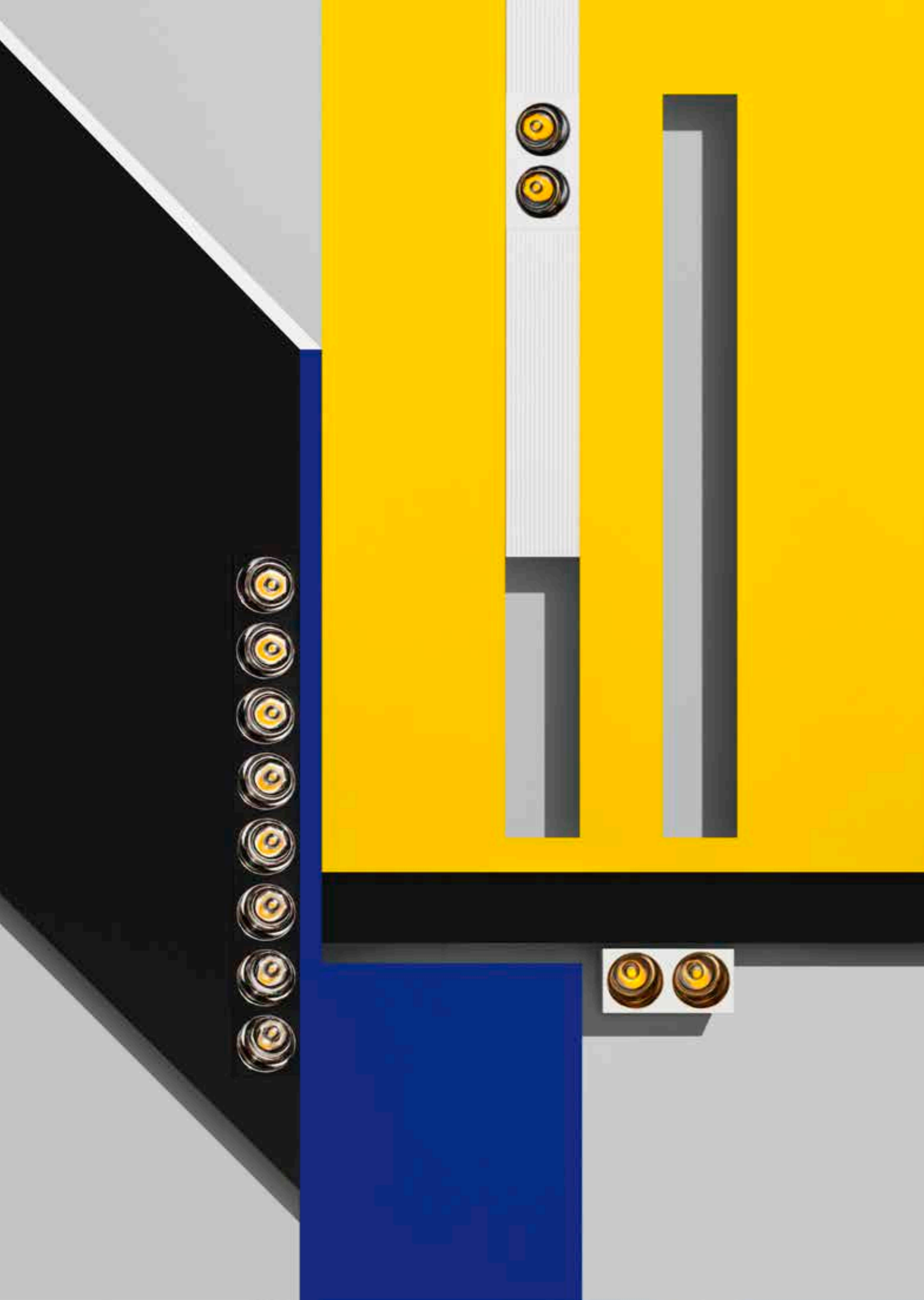

LIGHT SHADOW

Kompaktes Programm, um Blendung zu verhindern. Verschiedene Optiken, Größen und Verarbeitungen. Großartige Steuerung dank der patentierten Optikgruppe.

LIGHT SHADOW

Compact size program designed to avoid glare. Variety of optics, sizes and finishes. Great control thanks to its patented optical group.



DESIGNED BY FLOS ARCHITECTURAL

Die Revolution der blendarmen Beleuchtung. Dank seiner patentierten einzigartigen optischen Lösung erreicht der Light Shadow einen extremen Cutoffwinkel, ohne seine hohe Effizienz und super kleinen Masse einzubüßen.

The revolution in low glare lighting. Thanks to its patented unique optical solution, Light Shadow reaches extreme cut off angles without sacrificing high efficiency and very small dimensions.

Von FLOS entwickeltes LED-Board mit hochmodernen LED-Modulen. Top-Qualität und höchste Effizienz.

LED board designed by FLOS with state-of-the-art LED modules. High levels of quality and efficiency.



Von FLOS speziell für dieses Produkt entwickelte Optiken, die maximale Kontrolle und einen homogenen Lichtstrahl gewährleisten.

Lenses developed by FLOS especially for this product, to guarantee maximum control and a uniform beam.



Patentiertes System aus innovativen Konuselementen, die dank ihrer umgekehrt gewölbten Kurvenform eine enorme Schirmwirkung bieten.

Innovative patented cones system that provides extreme shielding thanks to its inverted curve form.

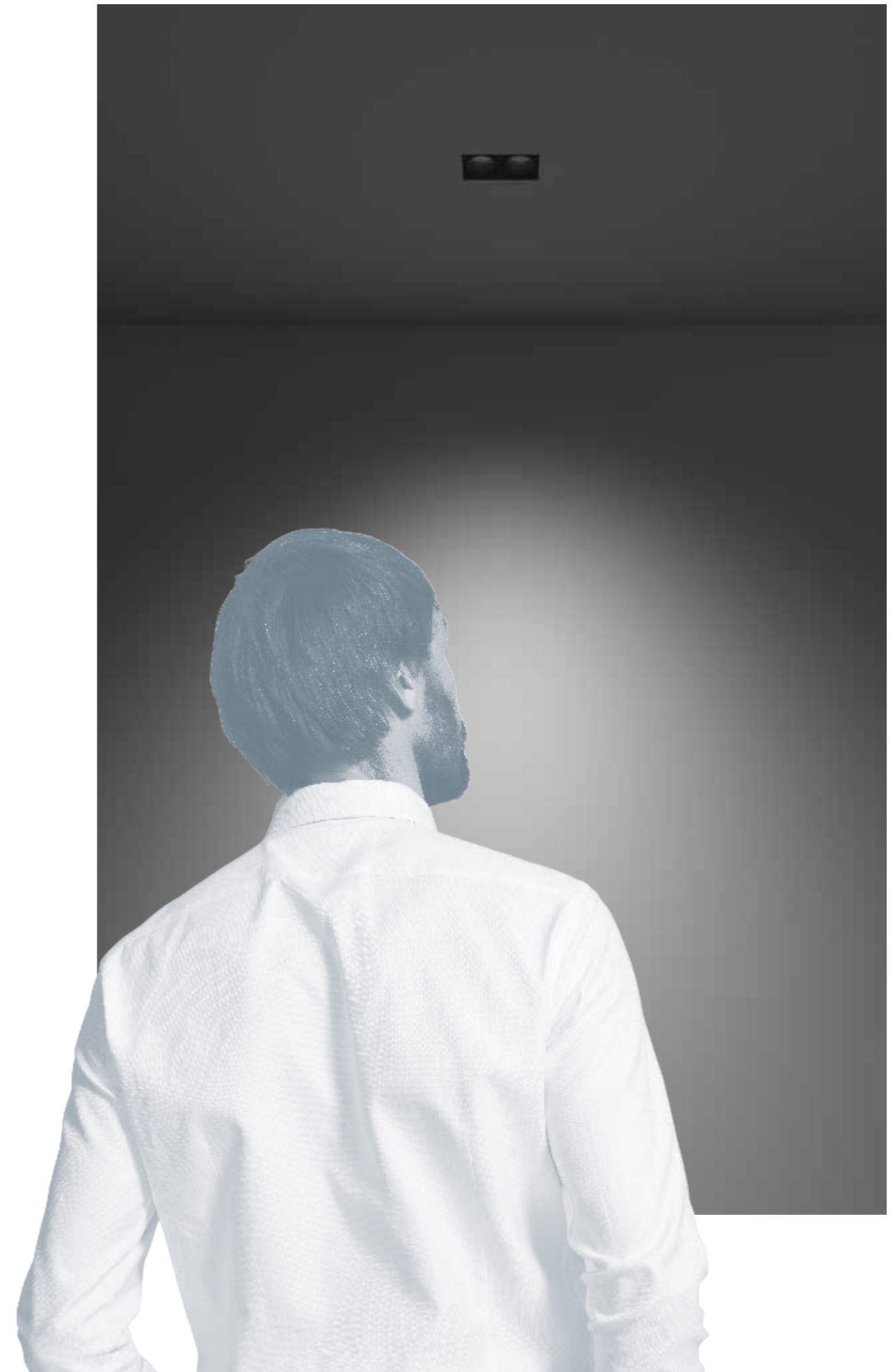

Traditional Technology



Mit konventioneller Technik entsteht eine Blendwirkung, gleichzeitig ist auch der Lichtstrahl nicht sehr präzise. Eine architektonische Integration ist nicht gegeben.

The traditional technology produces a glare effect while the beam of light is not so precise. Integration with architecture is not achieved.

Flos Technology

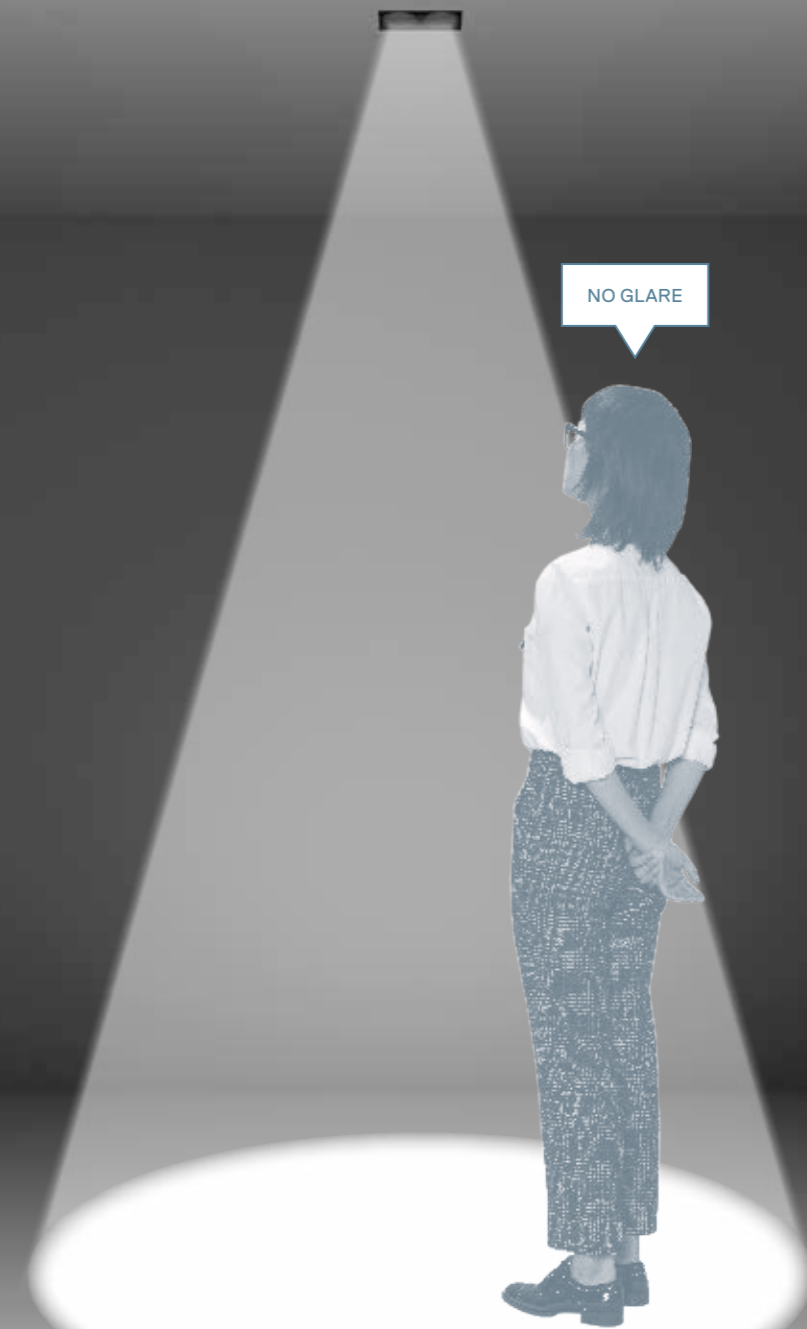

Die Light Shadow-Technologie und deren 40-Grad-Cut-off ermöglicht maximale architektonische Integration kombiniert mit einem perfekt definierten Lichtstrahl und absoluter Abschirmung. Dies lässt eine Positionierung mit fast senkrecht fallendem Licht ohne auftretende Blendwirkung zu.

Light Shadow technology thanks to its cut-off of 40 degrees, maximum integration with architecture combines with the impeccable, defined beam of light and total shielding, which allows it to be placed almost in zenithally position with no glare.

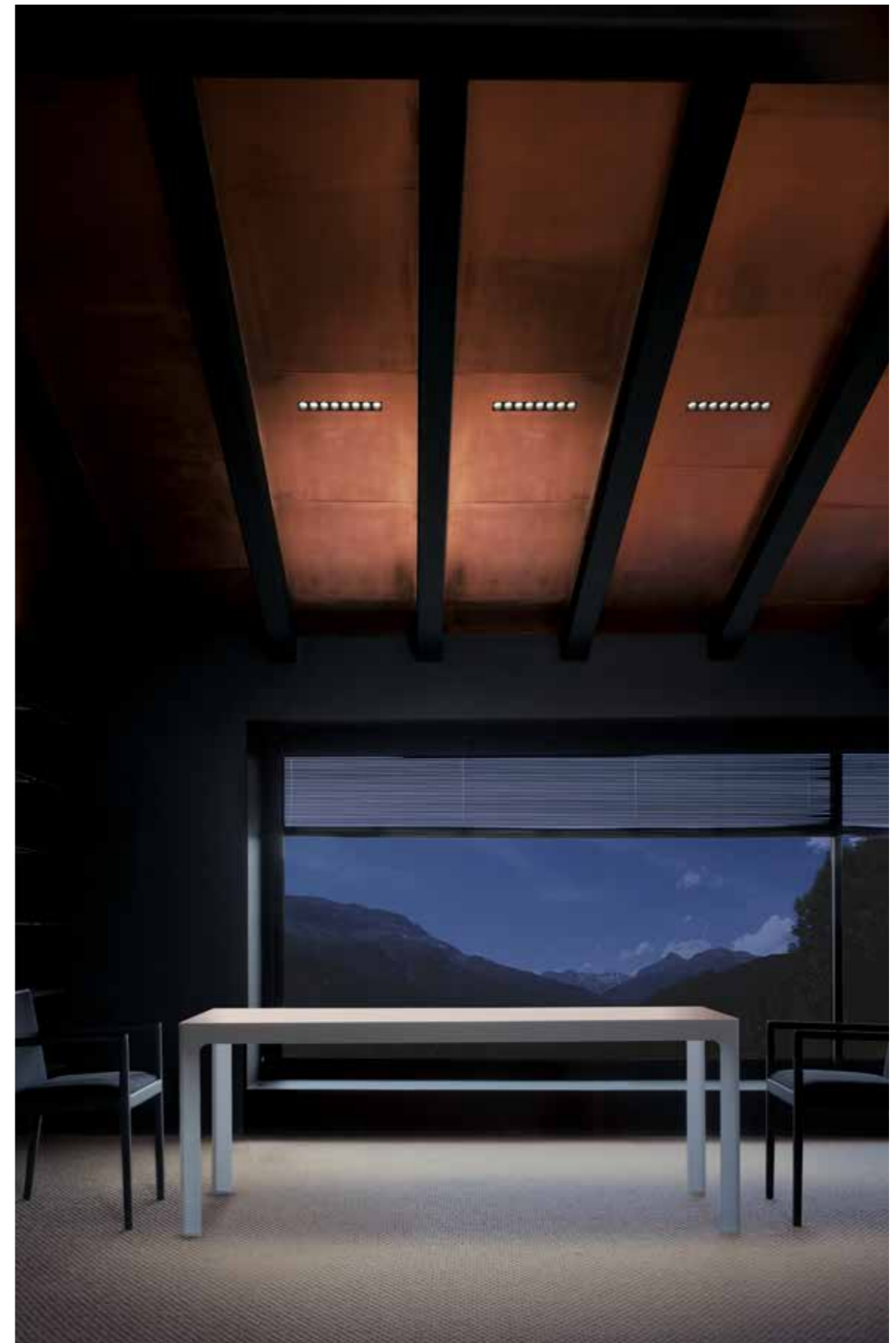

Die verstellbare Version ermöglicht die Entnahme des Grundkörpers, damit eine perfekte architektonische Integration und die volle Nutzung des Lichtstrahls gewährleistet wird.

The adjustable version allows the main body to be extracted to guarantee perfect integration with the architecture, and to make the most of the whole beam.

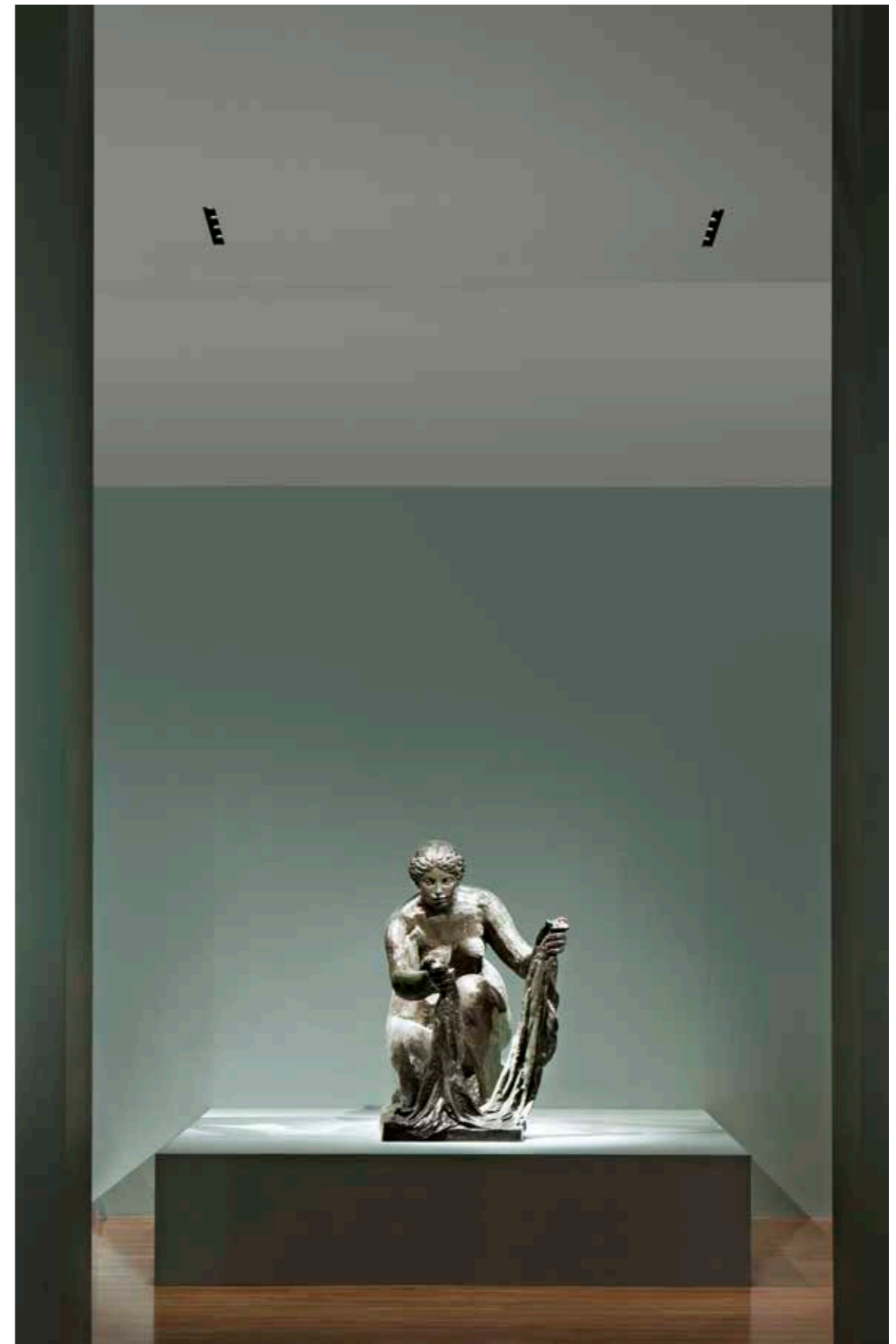

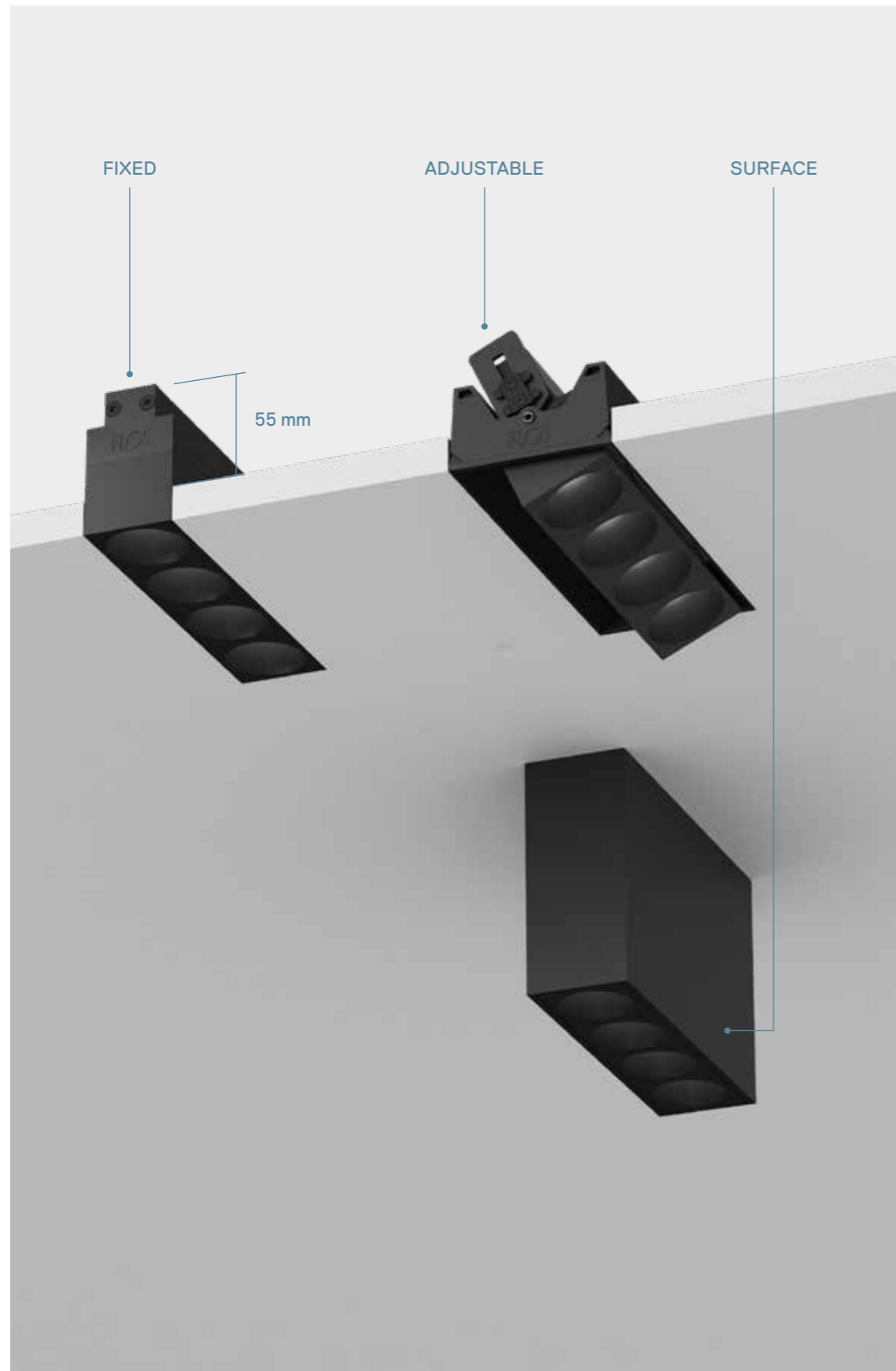

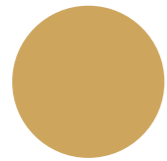

GOLD

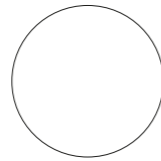

WHITE

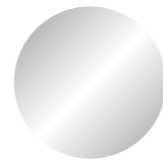

SILVER

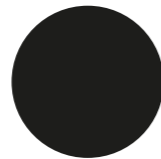

BLACK

Erhältlich ist die Kollektion in den Außenfarben Schwarz und Weiß, die sich mit verschiedenen Konusfarben kombinieren lassen. Diese reichen von Schwarz (konzipiert für höchsten Komfort) bis hin zu edleren Ausführungen in Weiß, Silber und Gold.

Collection available in black and white exterior finishes which are combined with different cone finishes, which go from black, developed to obtain the greatest level of comfort, to more sophisticated finishes such as white, silver and gold.

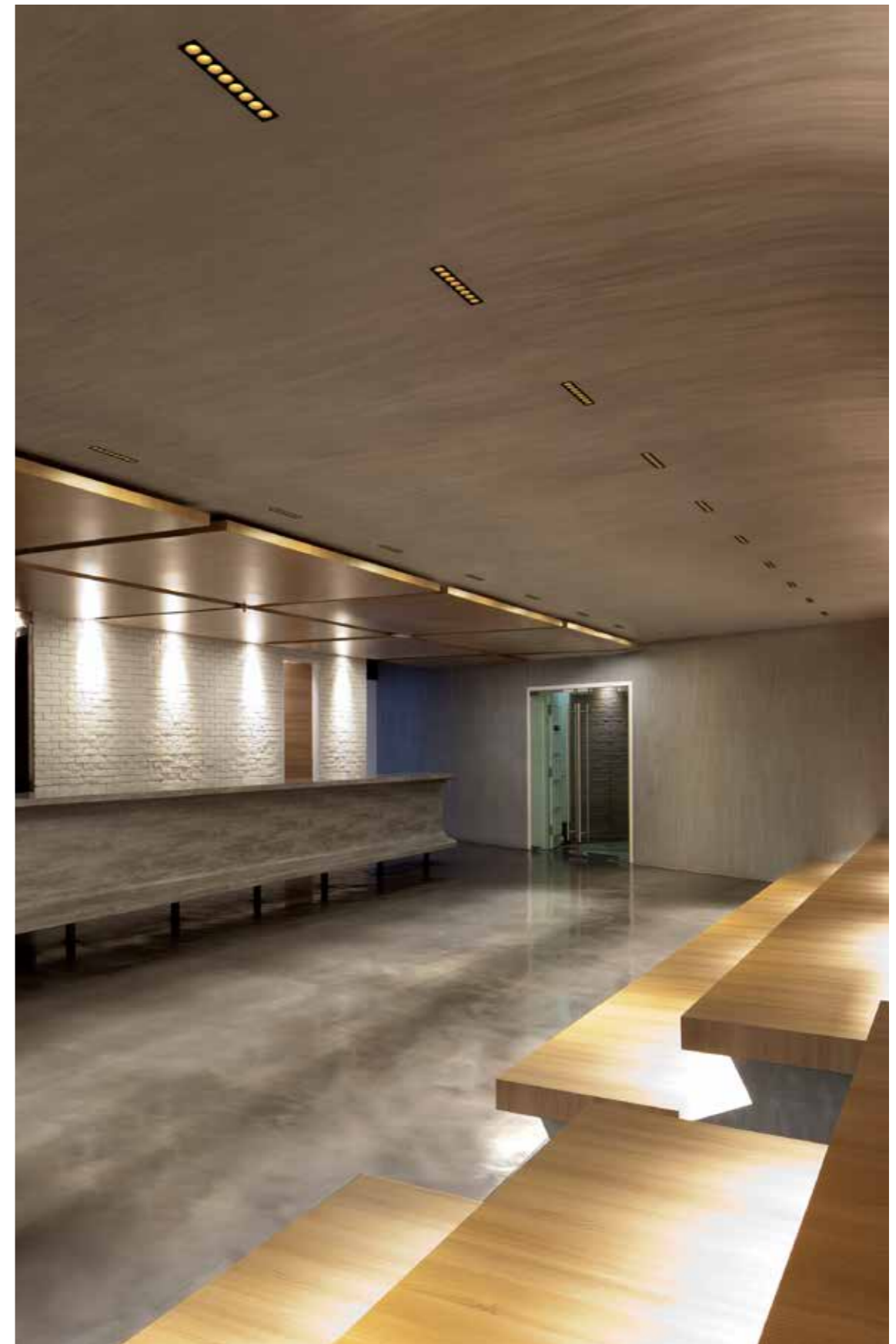

FIXED

TRIM/NO TRIM
2 SPOTS



POWER LED
2,7W x Spot

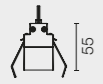
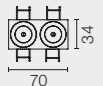
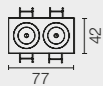

TRIM/NO TRIM
4 SPOTS

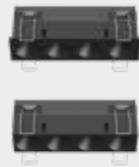

POWER LED
2,7W x Spot

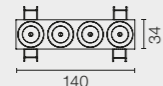
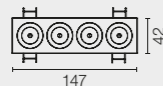

TRIM/NO TRIM
8 SPOTS



POWER LED
2,7W x Spot

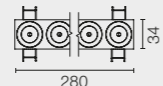
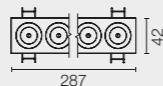

TRIM/NO TRIM
12 SPOTS



POWER LED
2,7W x Spot

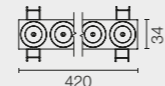
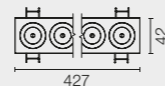

ADJUSTABLE

TRIM/NO TRIM
2 SPOTS



POWER LED
2,7W x Spot

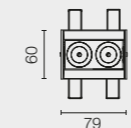
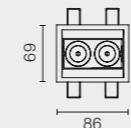

TRIM/NO TRIM
4 SPOTS



POWER LED
2,7W x Spot

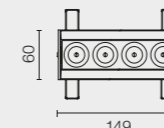
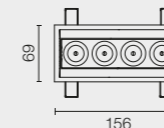

TRIM/NO TRIM
8 SPOTS



POWER LED
2,7W x Spot

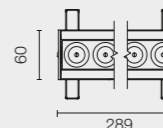
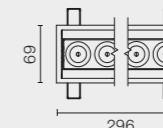

TRIM/NO TRIM
12 SPOTS



POWER LED
2,7W x Spot

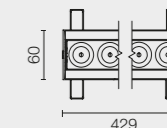
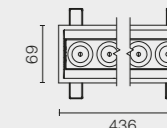

Light Shadow Fixed / Adjustable
Außen / Outside

- 40 Weiss 40 White
- 14 Schwarz 14 Black

Innen / Inside

HIGH COMFORT

- Schwarz Black
- Weiss White
- Chrom Chrome
- Mattgold Matt Gold

Light Shadow Surface
Außen / Outside
Box

- 40 Weiss 40 White
- 14 Schwarz 14 Black

Innen / Inside

- Schwarz Black
- Weiss White
- Chrom Chrome
- Mattgold Matt Gold

SURFACE 4 SPOTS



POWER LED
2,7W x Spot

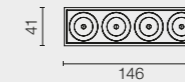

Kompaktes Einbausystem, das optimalen visuellen Komfort und die komplette Abschirmung gewährleistet. Die Lichtquellen sind zur Wartung der Leuchten frei zugänglich. Zubehör zur Lichtbündelung für die Akzentbeleuchtungen und zur Lichtstreuung für die allgemeine Beleuchtung. Die Installation in einer fortlaufenden Reihe ist ebenfalls möglich.

THE BLACK LINE

A small-sized embedded system with maximum visual comfort and total screening. Absolute accessibility to the sources of light to feed the luminaires. Closed optics solutions for accent illumination or open for general illumination, enabling a continuous line composition.







Abnehmbare Abschirmkegel aus Silikon sorgen für visuellen Komfort und ermöglichen nach der Installation den freien Zugang zur Elektronik.

Dismountable silicon screening cones to ensure visual comfort and a complete accessibility to the electronics after installation.



Das Modell No Trim kann in einer fortlaufenden Reihe installiert werden.

The No Trim version can be installed in a continuous line.



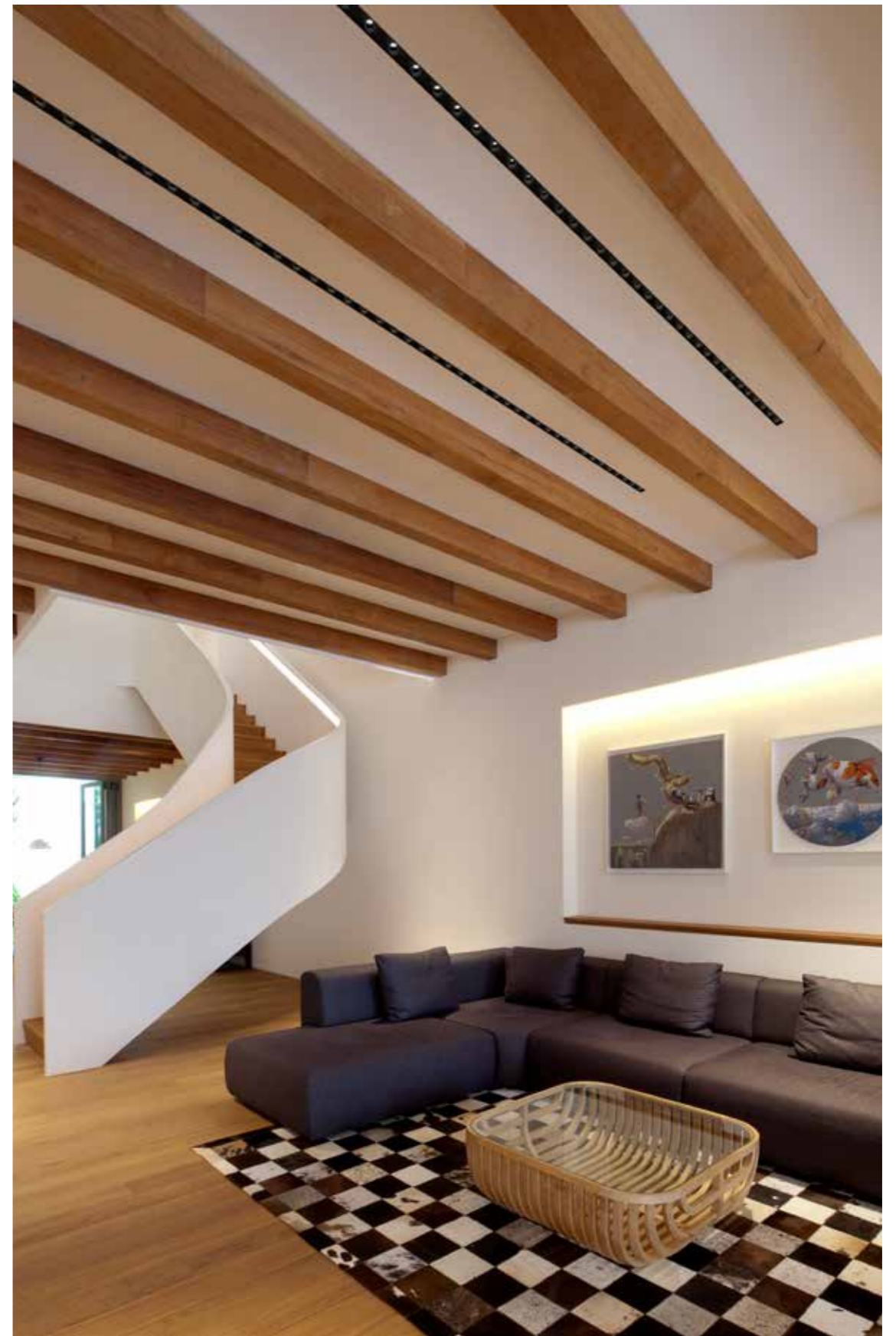



THE BLACK LINE

THE BLACK LINE

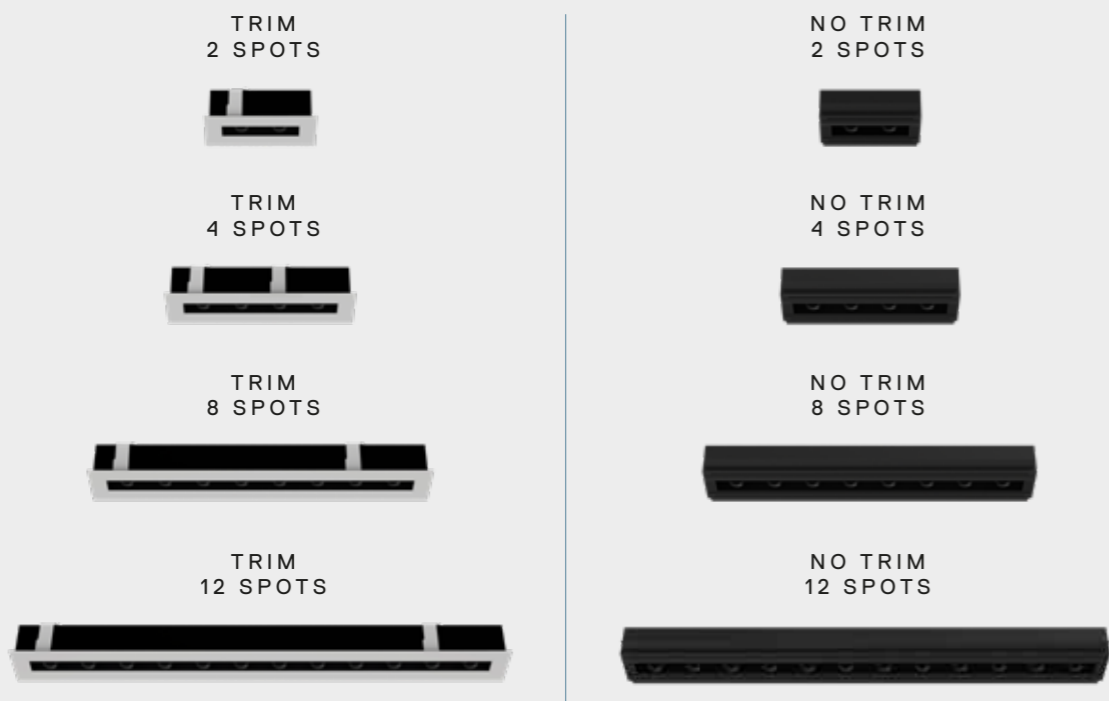

POWER LED
3,2W x Spot

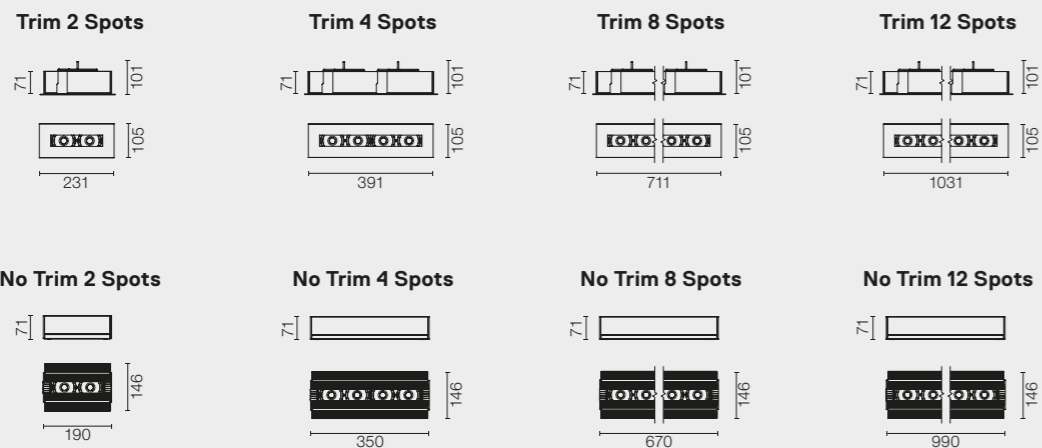

The Black Line
Trim

00 Grundierung
00 Primer

40 Weiss
40 White



The Black Line
No Trim

14 Schwarz
14 Black





CIRCLE OF LIGHT

Produktfamilie von Rundleuchten zum Deckeneinbau, die sich dank der Soft Architecture Technologie perfekt einfügen. Circle of Light besteht aus einem Außenrahmen aus Verbundmaterial, auf dem eine Metallstruktur als Halterung für die LED-Strahler der jüngsten Generation dient. Enthält Linsen zur Optimierung der Lichteffizienz der Leuchte sowie Blendschutzkegel, um hohen Sehkomfort zu gewährleisten.

CIRCLE OF LIGHT

Family of circular ceiling-mounted recessed luminaires, which are totally integrated owing to Soft Architecture technology. The Circle of Light is comprised of an outer frame made with composite that houses a metal structure. This, in turn, acts as support for the latest generation LED spotlights. Its lenses optimise the luminous performance of the luminaire together with anti-glare cones that guarantee high visual comfort.



DESIGNED BY FLOS ARCHITECTURAL





Vorinstallation auf einem Profil vom Typ "Soft Architecture" für eine perfekte Integration in der Decke.

Pre-installation on "Soft Architecture" type profile for perfect integration into ceiling.



Als Abschirmung für besseren Cut-off und höheren Sehkomfort.

Cut-off cone for greater cut-off and enhancement of visual comfort.

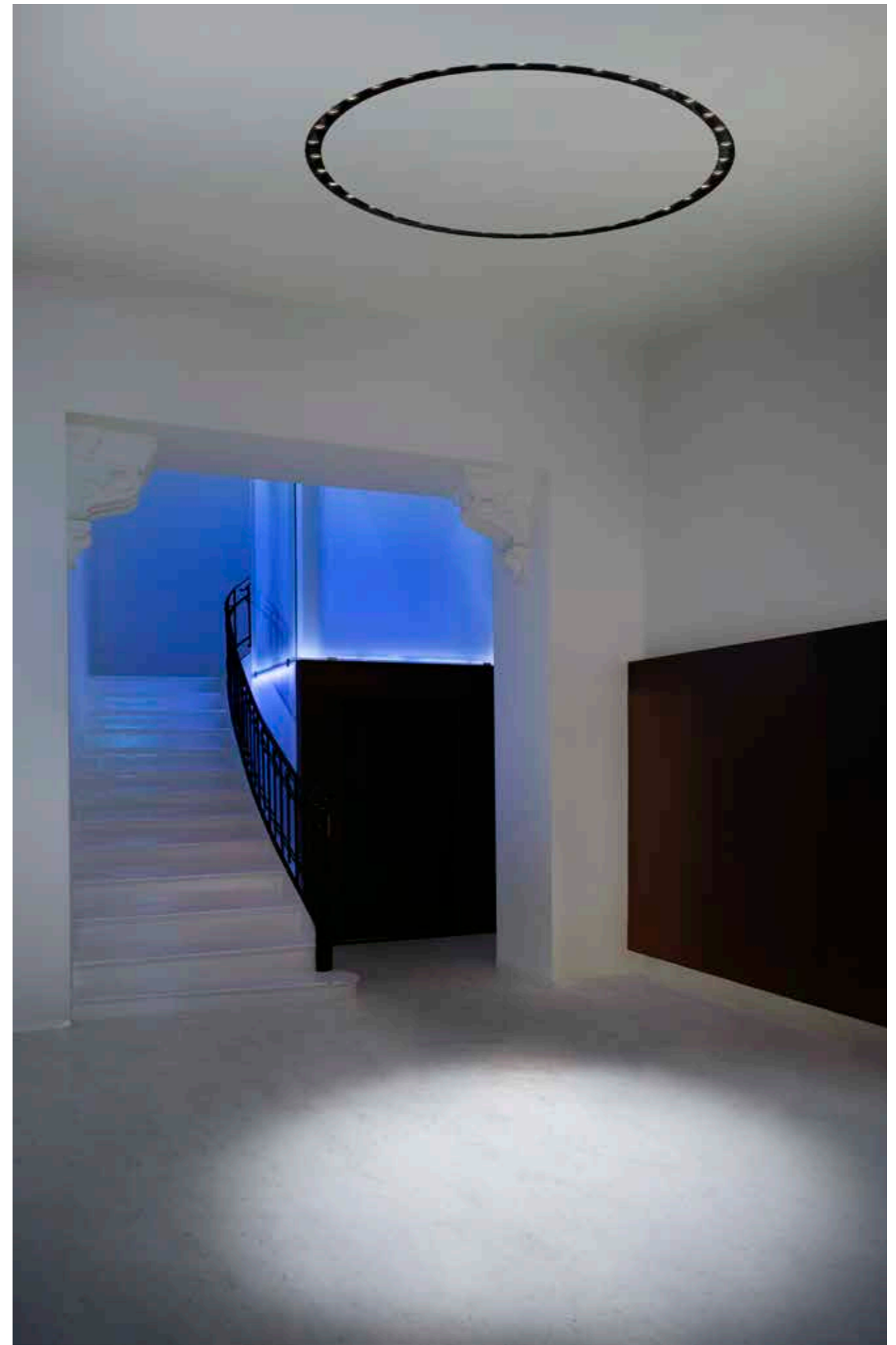

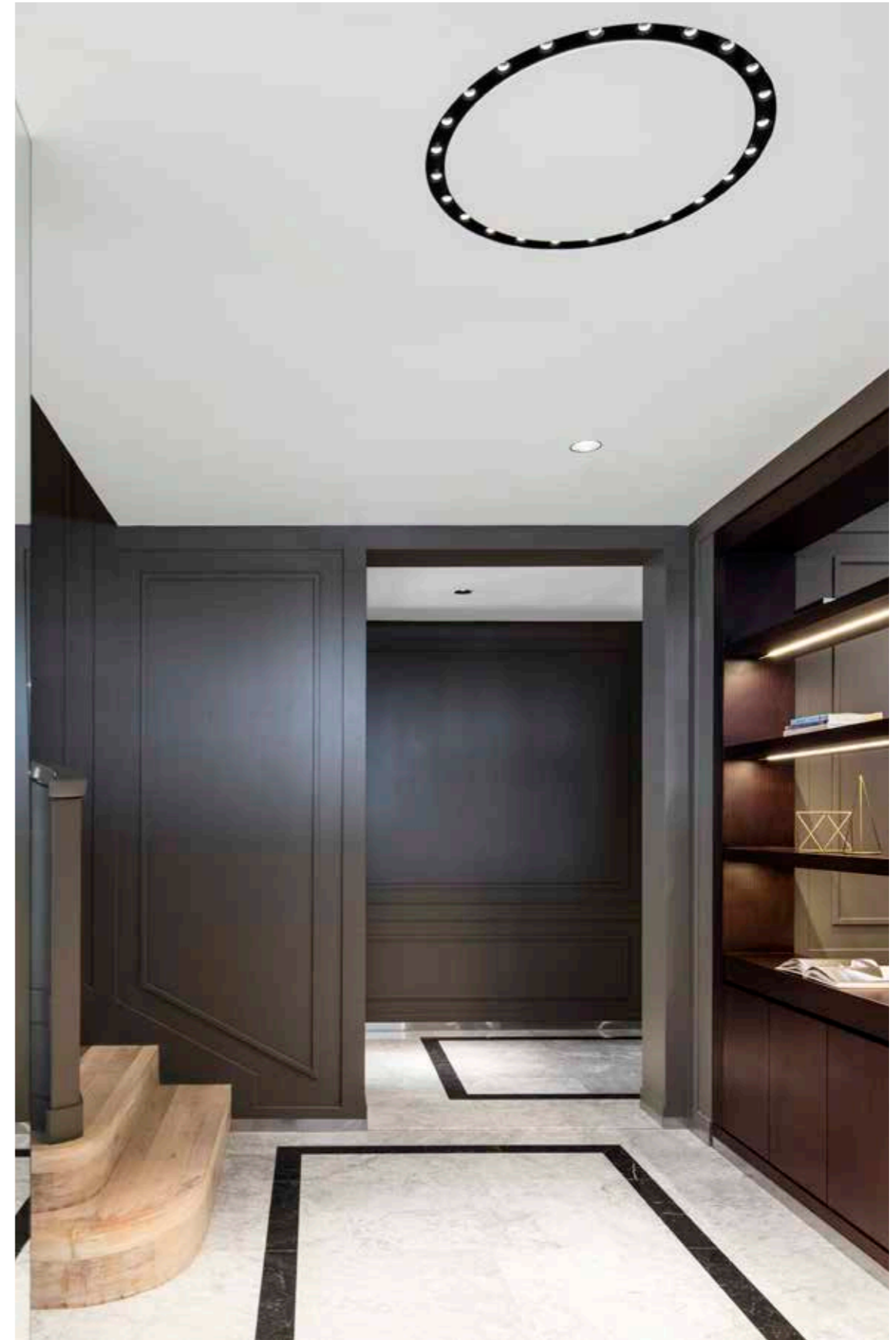



CIRCLE OF LIGHT

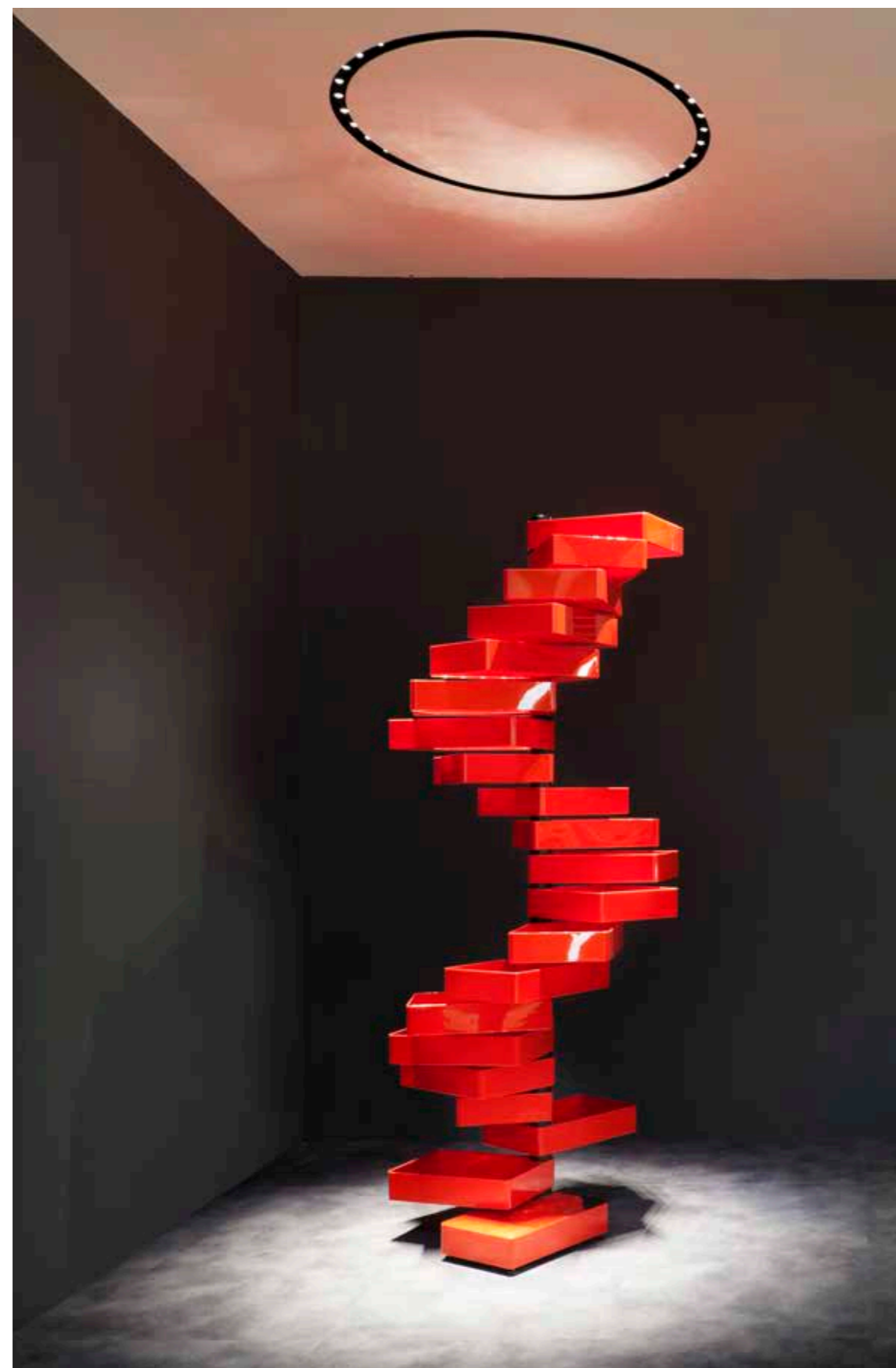

FLOS SHOWROOM - ITALY

CIRCLE OF LIGHT

CIRCLE OF LIGHT
300mm



POWER LED
12x3W



CIRCLE OF LIGHT
600 mm



POWER LED
24x3W

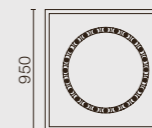

CIRCLE OF LIGHT
900 mm



POWER LED
36x3W

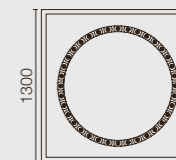

■ 14 Schwarz
■ 14 Black



reddot design award
winner 2013



LED CURTAIN

Einbauleuchte mit LED-Lichtquelle. Speziell für die Wallwasher-Beleuchtung konzipiert, verfügt Led Curtain über elliptische Linsen für eine perfekte Lichtverteilung. Die Produktfamilie Led Curtain weist unterschiedliche Längen auf, die miteinander verbunden werden können, um sich den unterschiedlichsten Räumen anzupassen. Perfekte Integration in die Architektur dank kleiner Abmessungen.

LED CURTAIN

Recessed luminaire equipped with LED light source. Especially designed for wall-washer lighting, the Led Curtain incorporates elliptical lenses for perfect light distribution. The Led Curtain family comes in different lengths that can be interconnected, thus easily adapting to different spaces, and due to its small size it integrates easily into the architecture.





LED CURTAIN

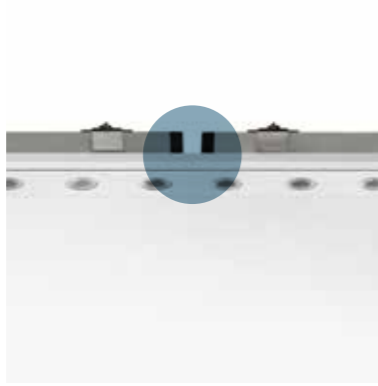

Lichtmodule, die mit einem Verbindungskabel mit Schnellanschluss vom Typ Tyco zusammengeslossen werden können.

Interconnectable light modules using connection cable and Tyco type faston connection.

LED CURTAIN

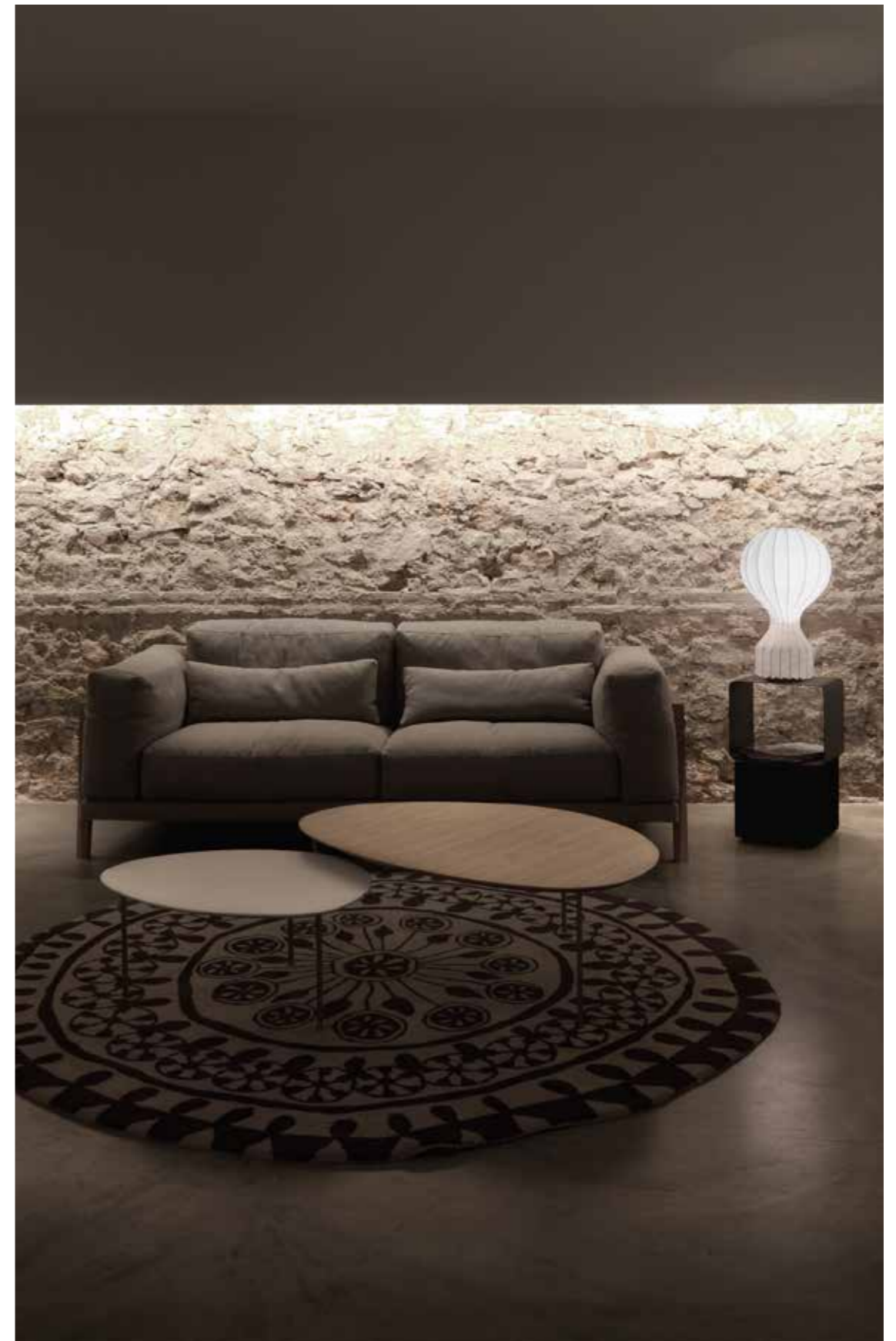

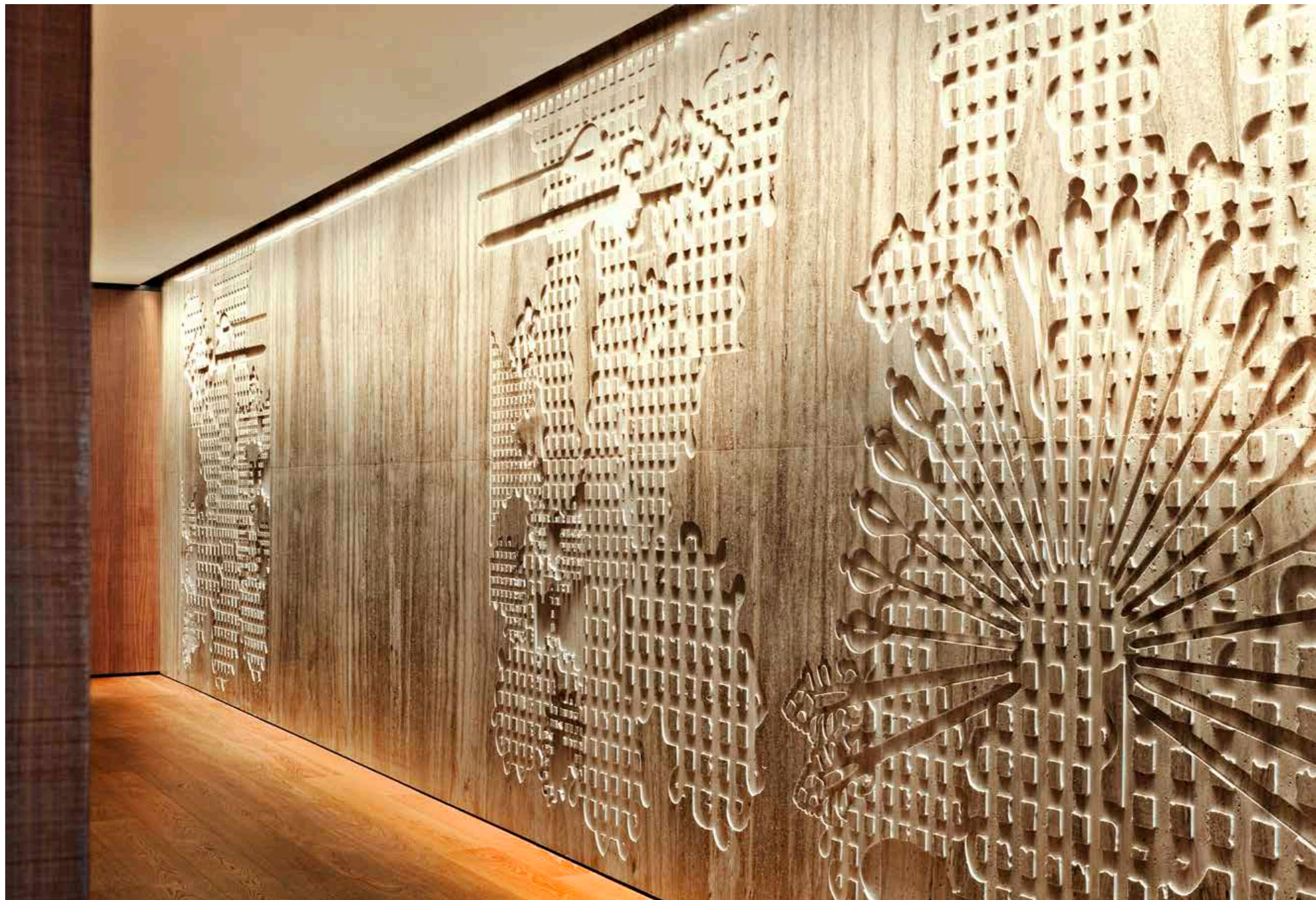

LED CURTAIN

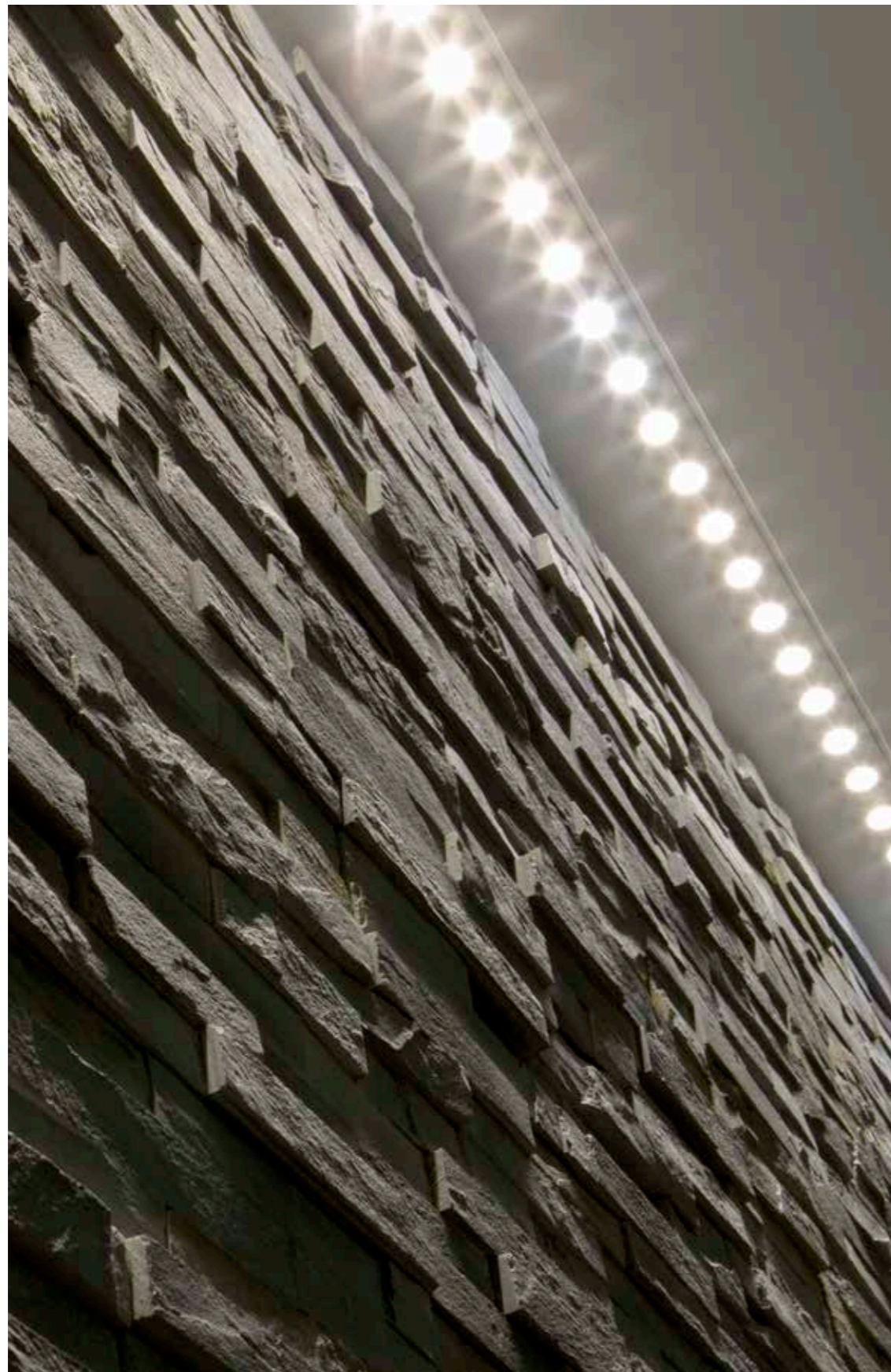

LED CURTAIN



POWER LED
29W/m



L : 150 / 300 / 600 / 900 / 1200



30 Weiss
30 White





THIN LED

Wandleuchte für indirekte Beleuchtung. Wesentlicher und minimaler Umriss, der sich in den umliegenden Architekturraum perfekt einfügt. Ihre Abmessungen sind sehr klein, trotzdem gewährleistet sie eine sehr hohe Beleuchtungsleistung. Dies ist ein einmaliges Gerät, das eine perfekt gleichmäßige asymmetrische Beleuchtung gewährleistet.

THIN LED

Wall-mounted profile for indirect lighting. Essential and minimal for perfect integration into the surrounding architectural space. Thin, but with really high lighting performances. A unique device for even and spotless asymmetrical lighting.



DESIGNED BY FLOS ARCHITECTURAL

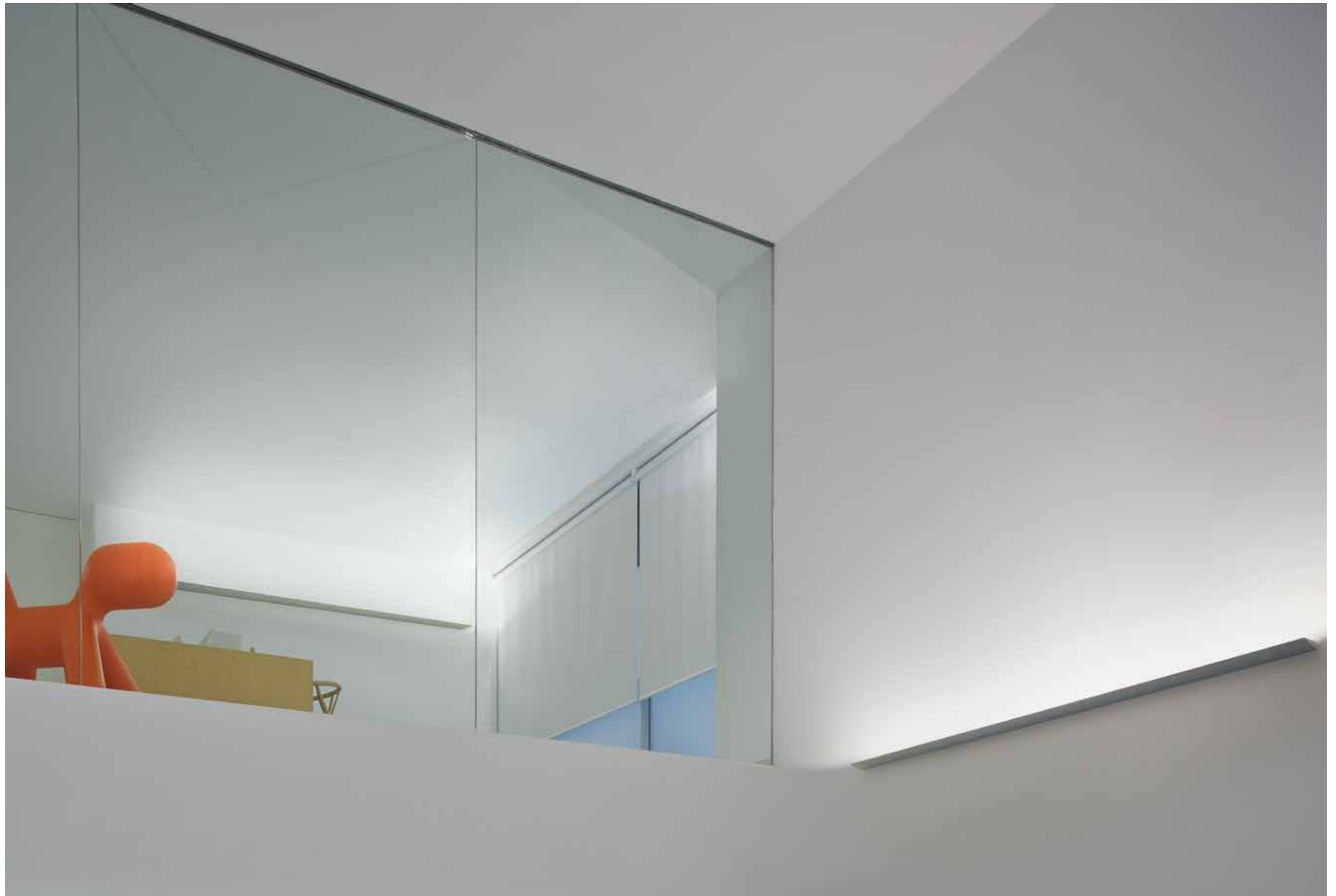



Für eine korrekte Projektplanung muss die Leuchte unter Berücksichtigung der angemessenen Relation zwischen Raumhöhe und Distanz der Leuchte zur Decke installiert werden.

The correct relationship between room height and distance from luminaire to ceiling must be respected when installing the luminaire, for a correct planning within the project.



THIN LED

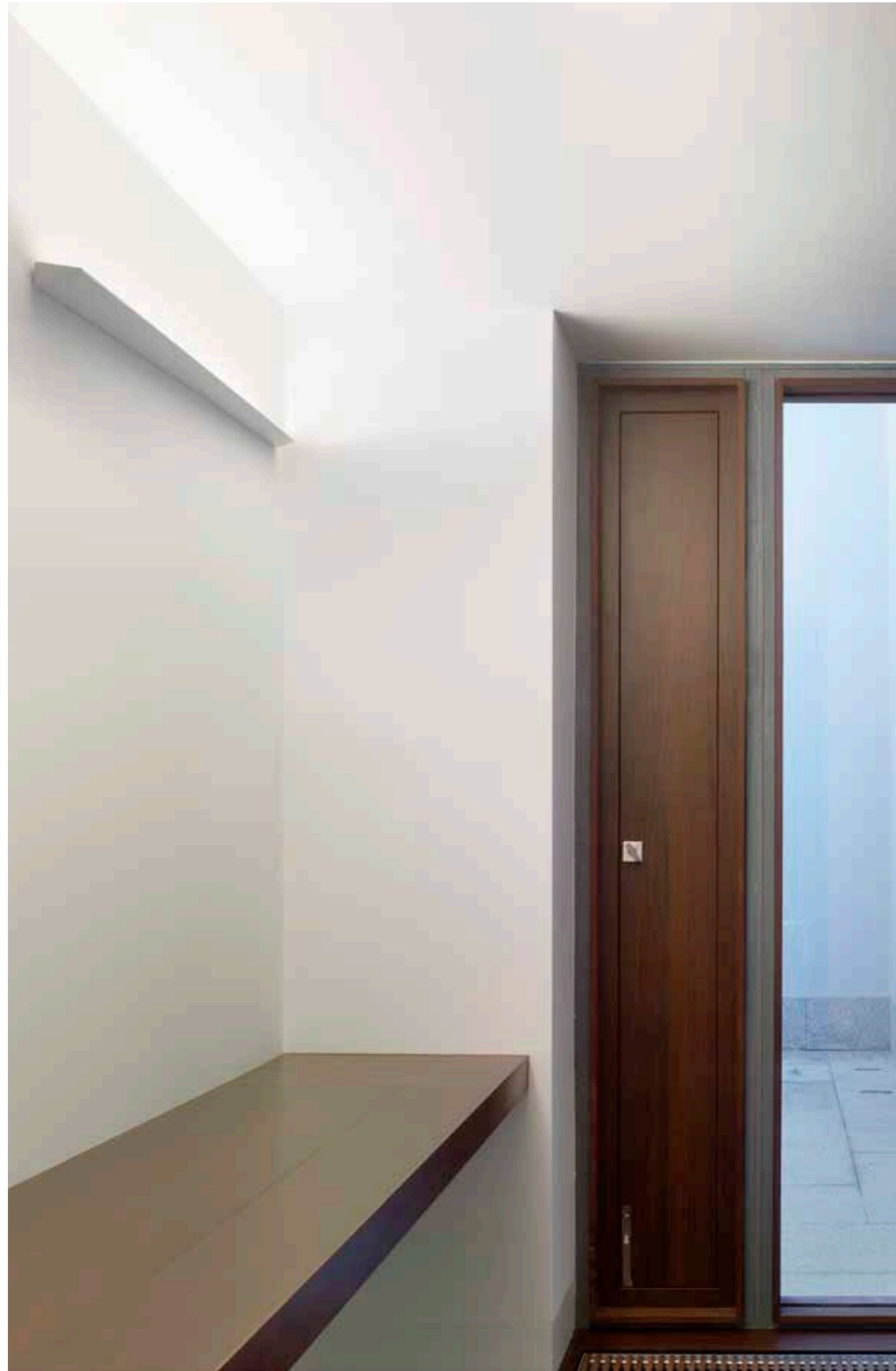

272

THIN LED

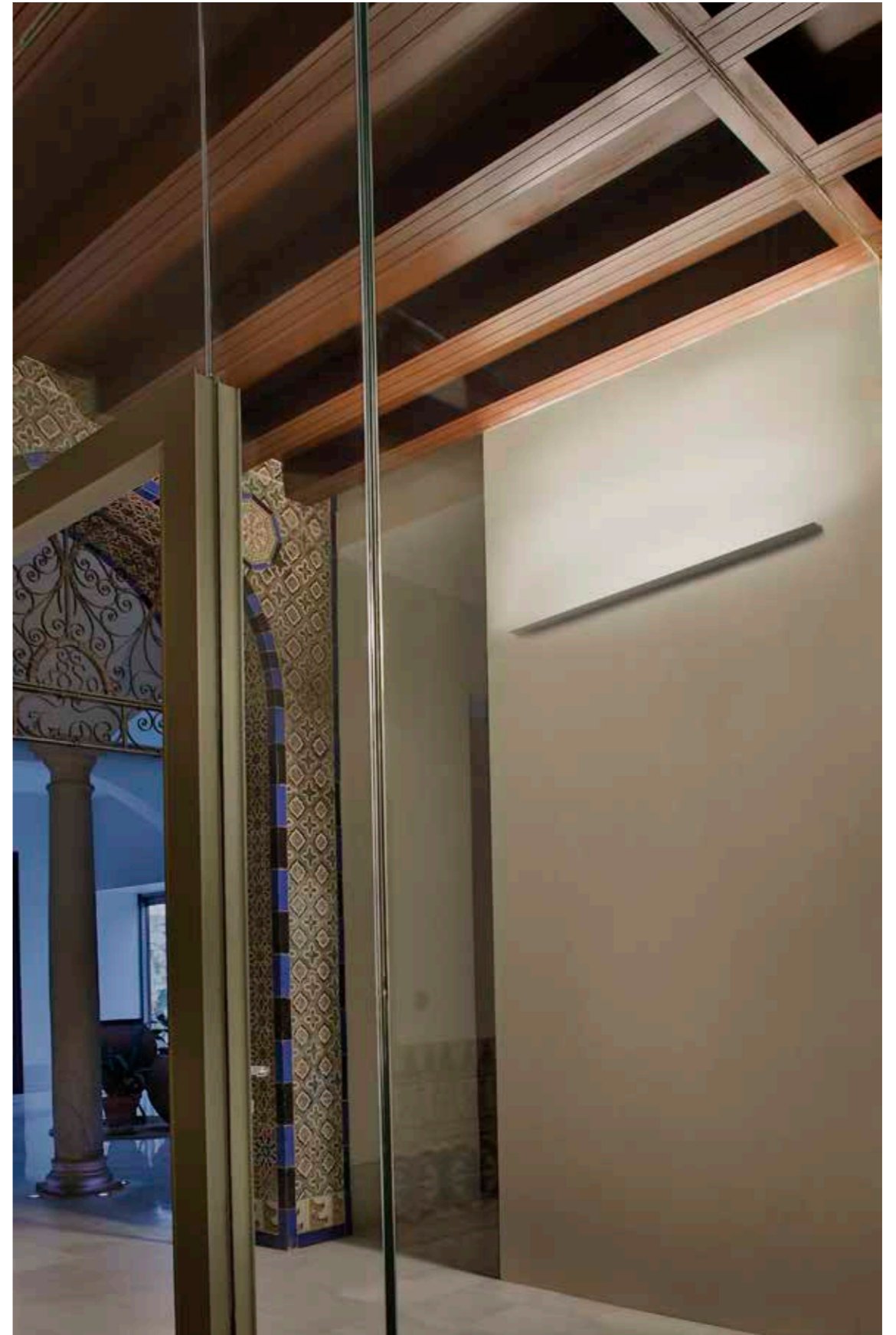

273

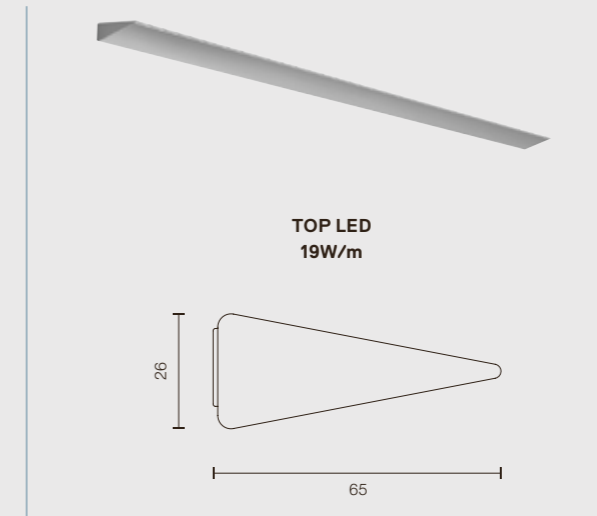
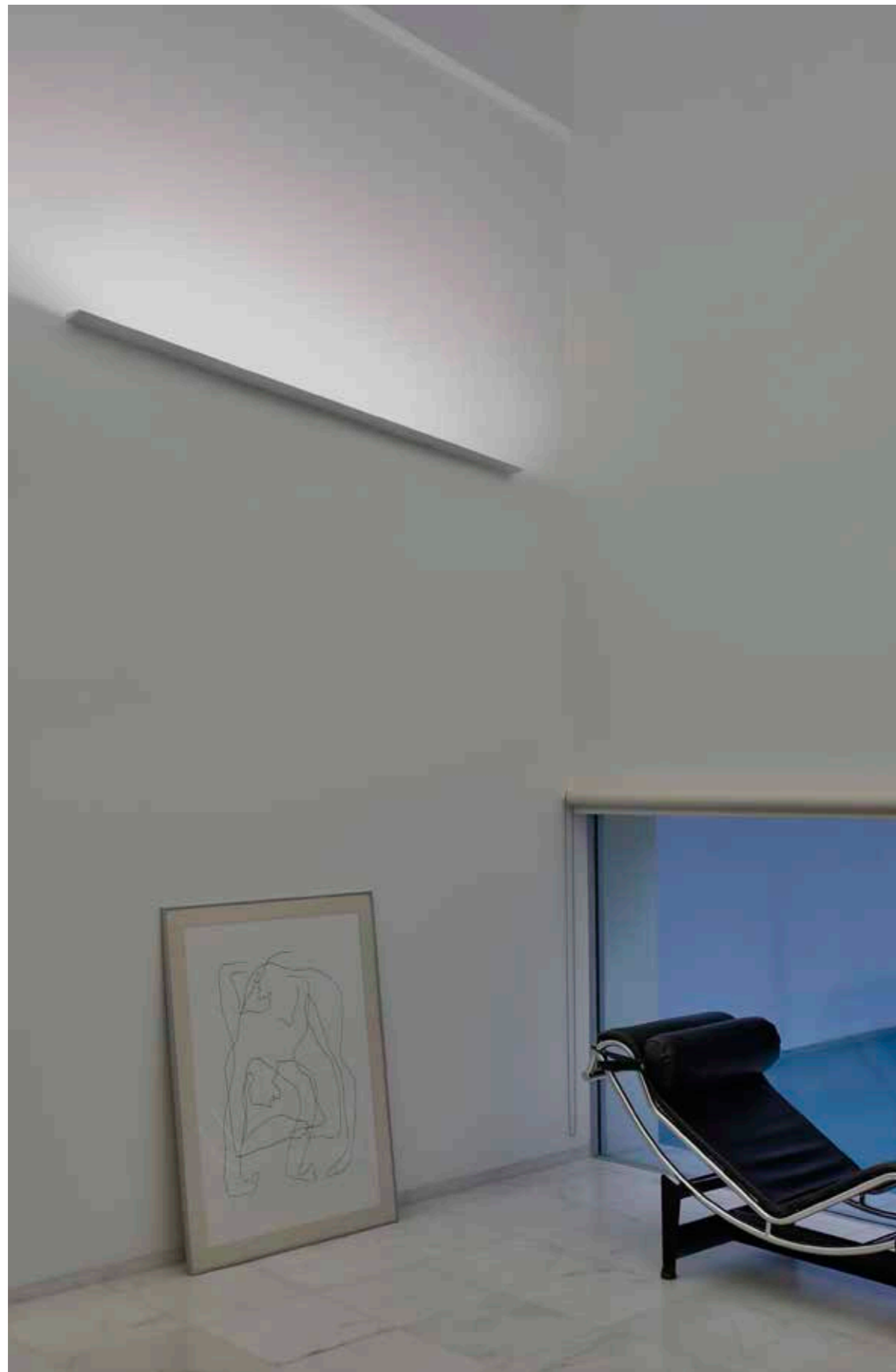

30 Weiss
30 White

29 Eloxiertes Aluminium
29 Anodized Aluminium

BZ Eloxiertes Bronze
BZ Anodized Bronze



Dies modell wurde patentiert und eingetragen / Patented and registered model

Minimalistische und funktionale Leuchte als natürliche Weiterentwicklung des von Philippe Starck designten Modells Fort Knox. Jetzt jedoch mit exklusiv von Flos entworfener LED-Linse. Fort Knox Wall ist ein Leuchtmittel von grober Struktur, das einen sehr starken indirekten Lichtkegel erzeugt und somit perfekt geeignet ist für hervorstehende Decken, an denen es als natürlicher Diffusor dient.

FORT KNOX

Minimalist and functional luminaire, natural evolution of the Fort Knox model, designed by Philippe Starck but now including a LED lens exclusively designed by Flos. Fort Knox Wall is a luminaire with coarse structure that produces an indirect and very powerful light beam, perfect for homes with protruding ceilings, working as natural diffuser.

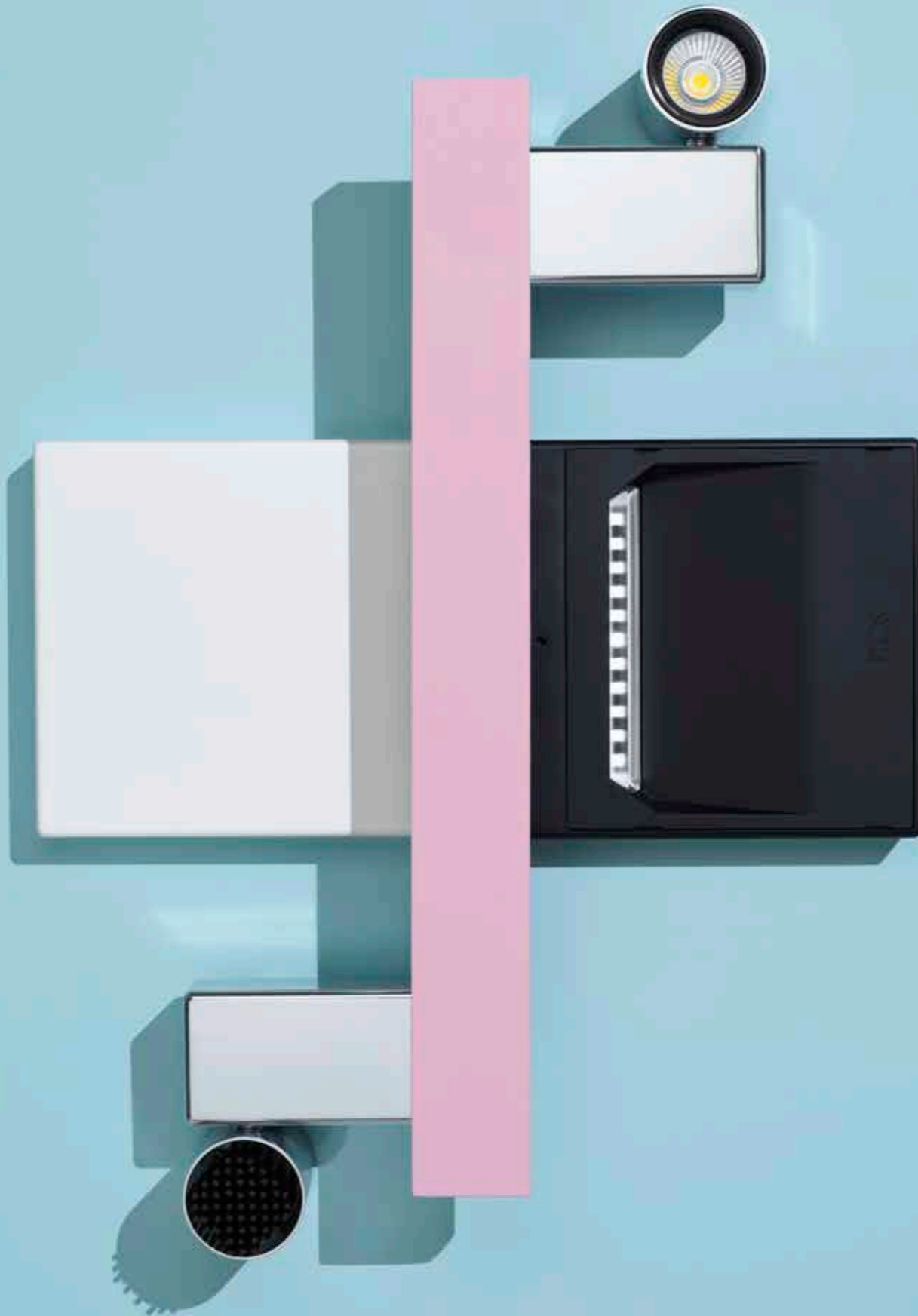

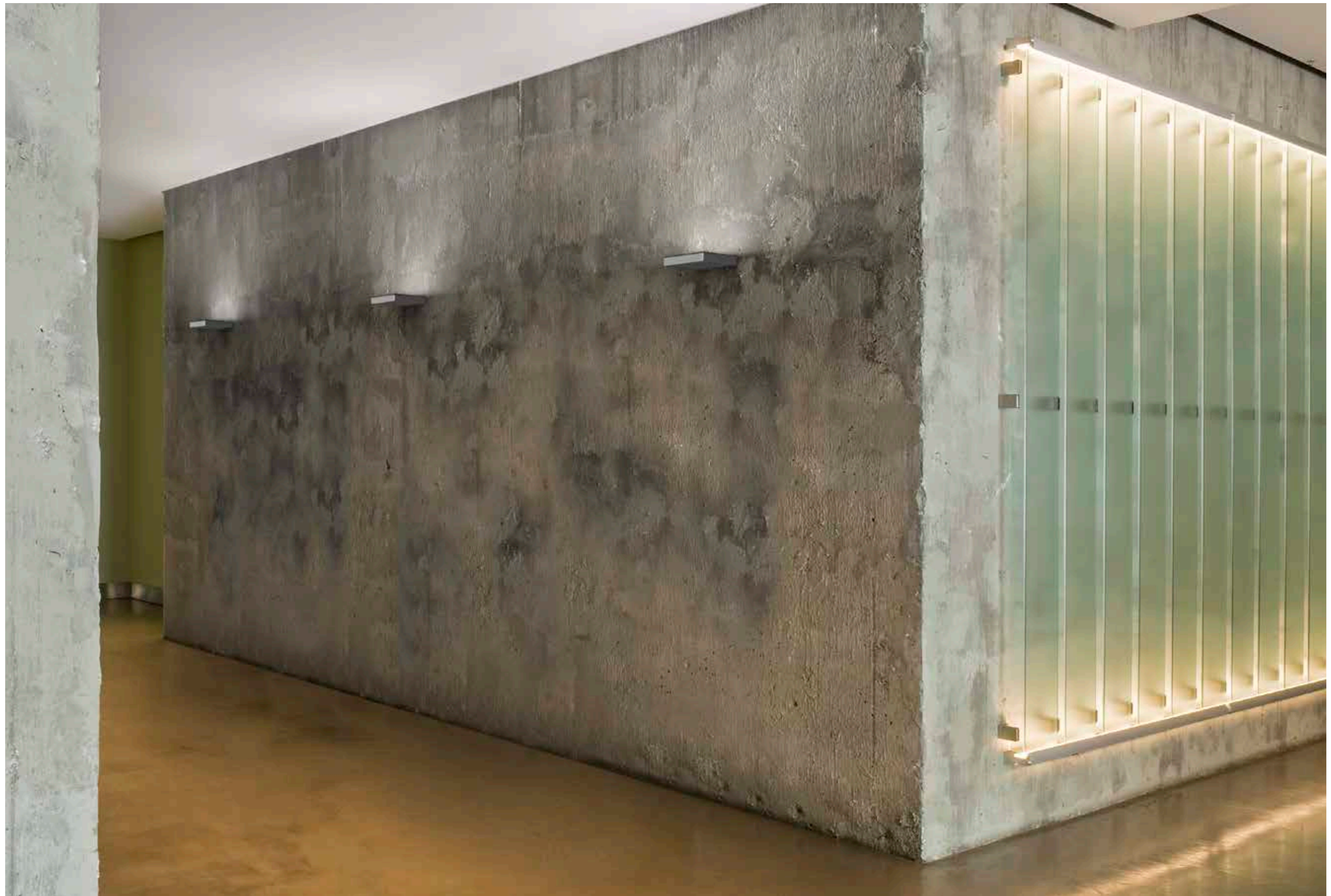

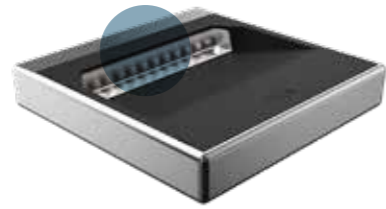

Oberstück mattschwarz antireflex.

Matte black, anti-reflective top section.

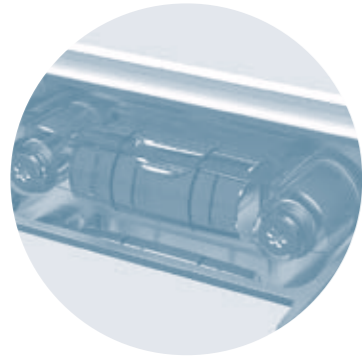

Leichte Installation.

Level for easy, integrated installation.

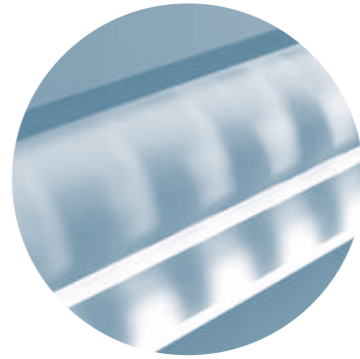

Hoch leistungsfähige Linse, die den Lichtstrahl nach oben richten kann.

Highly efficient lens which directs the beam of light upwards.

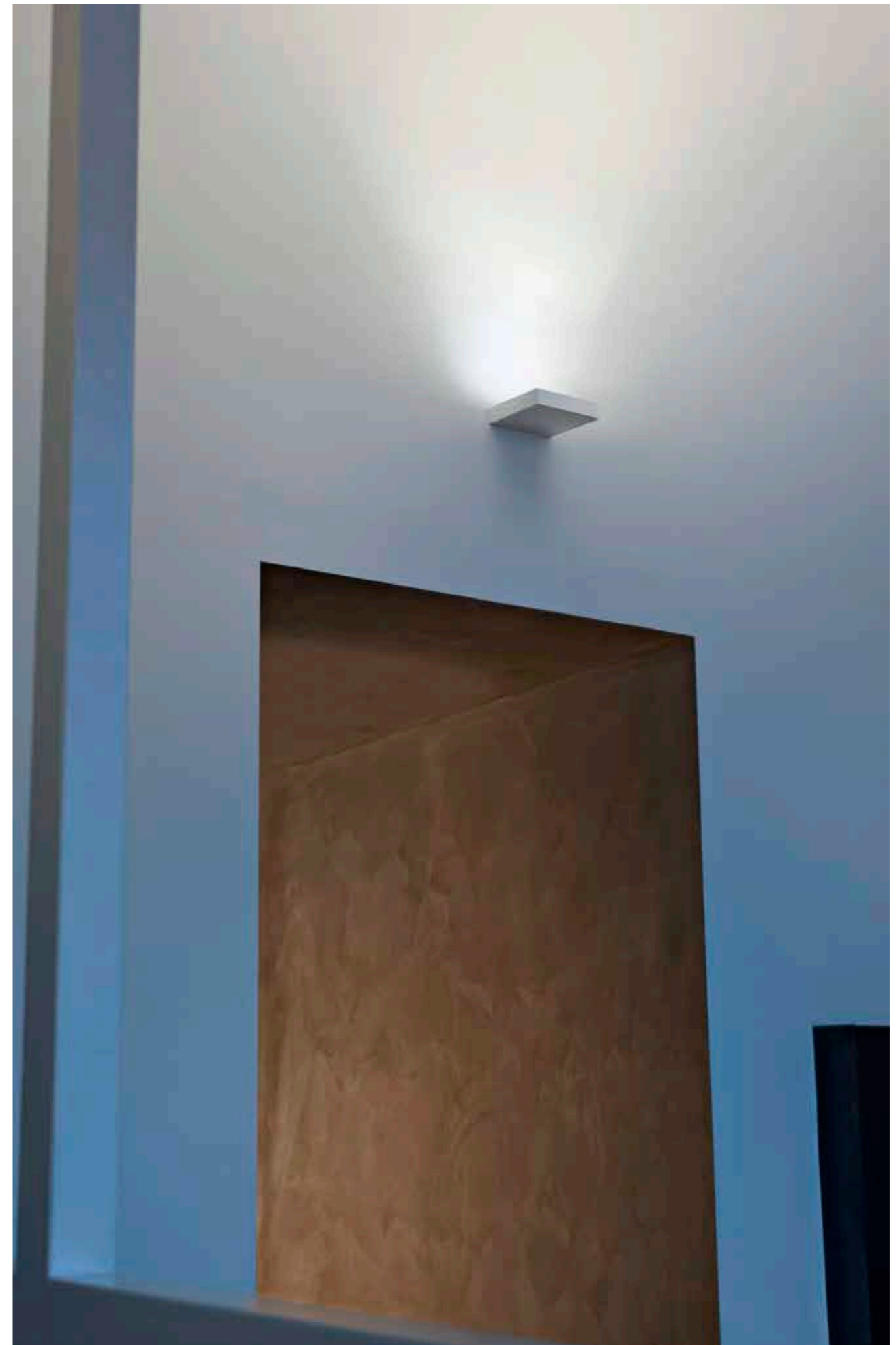

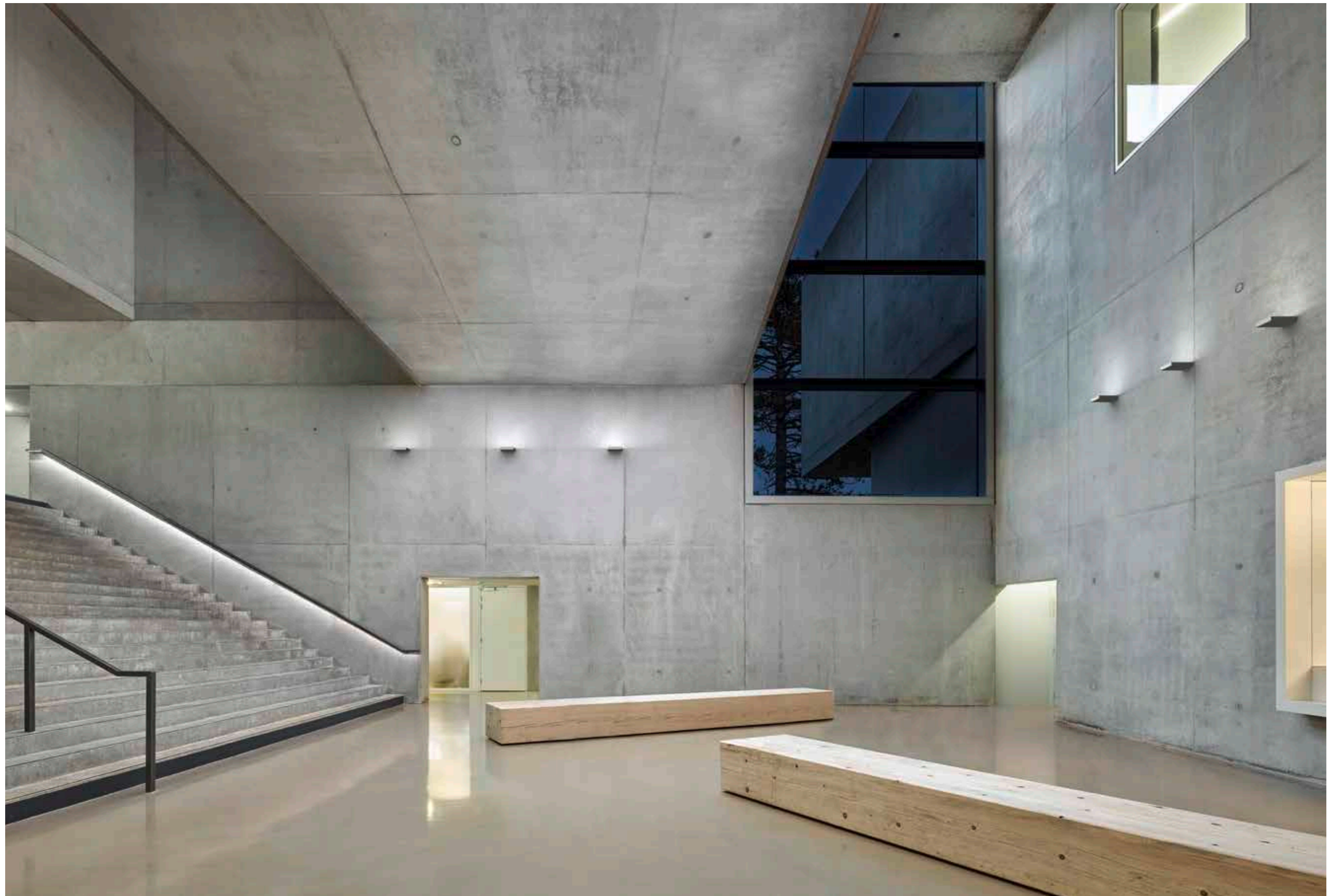

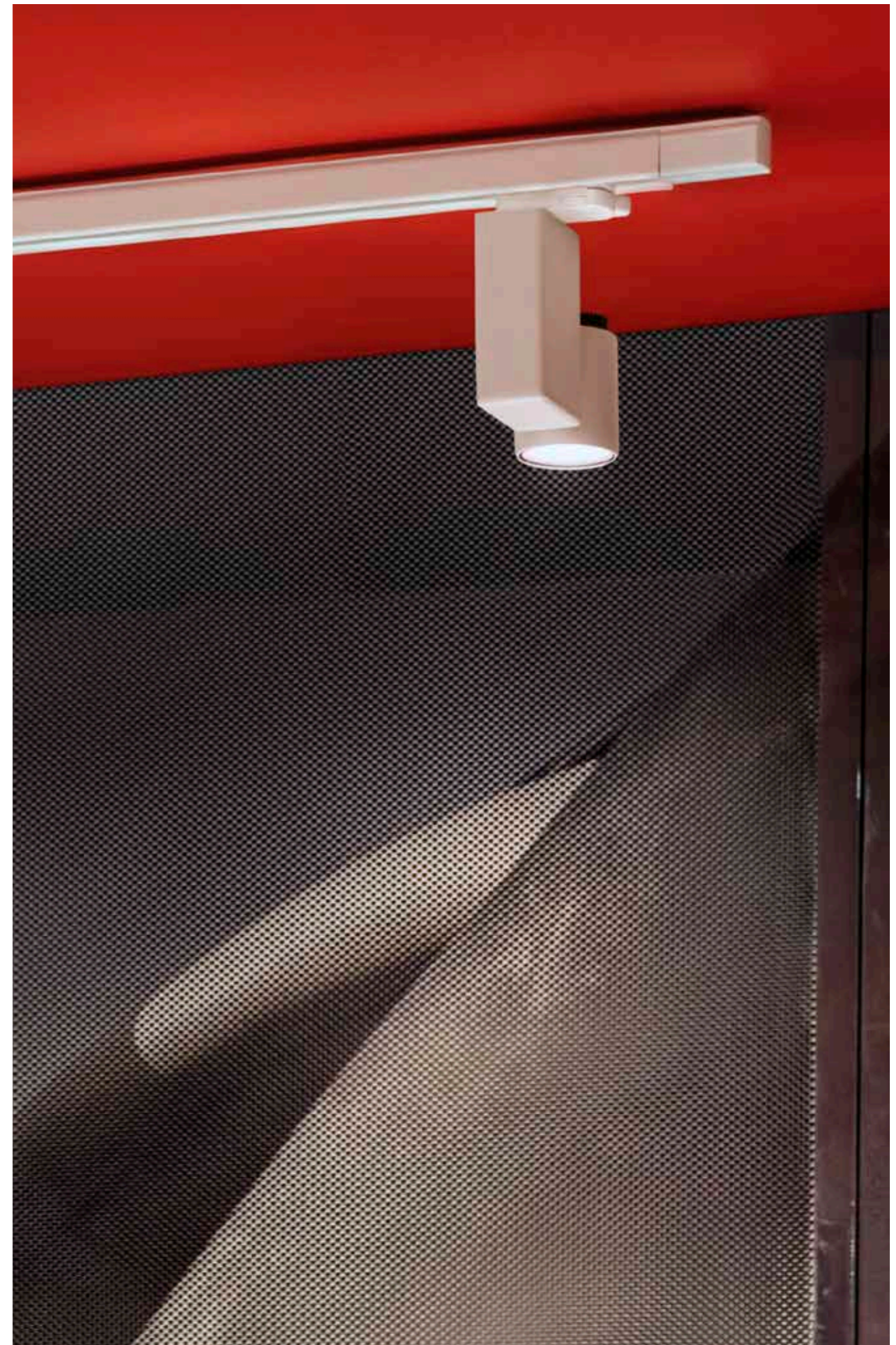

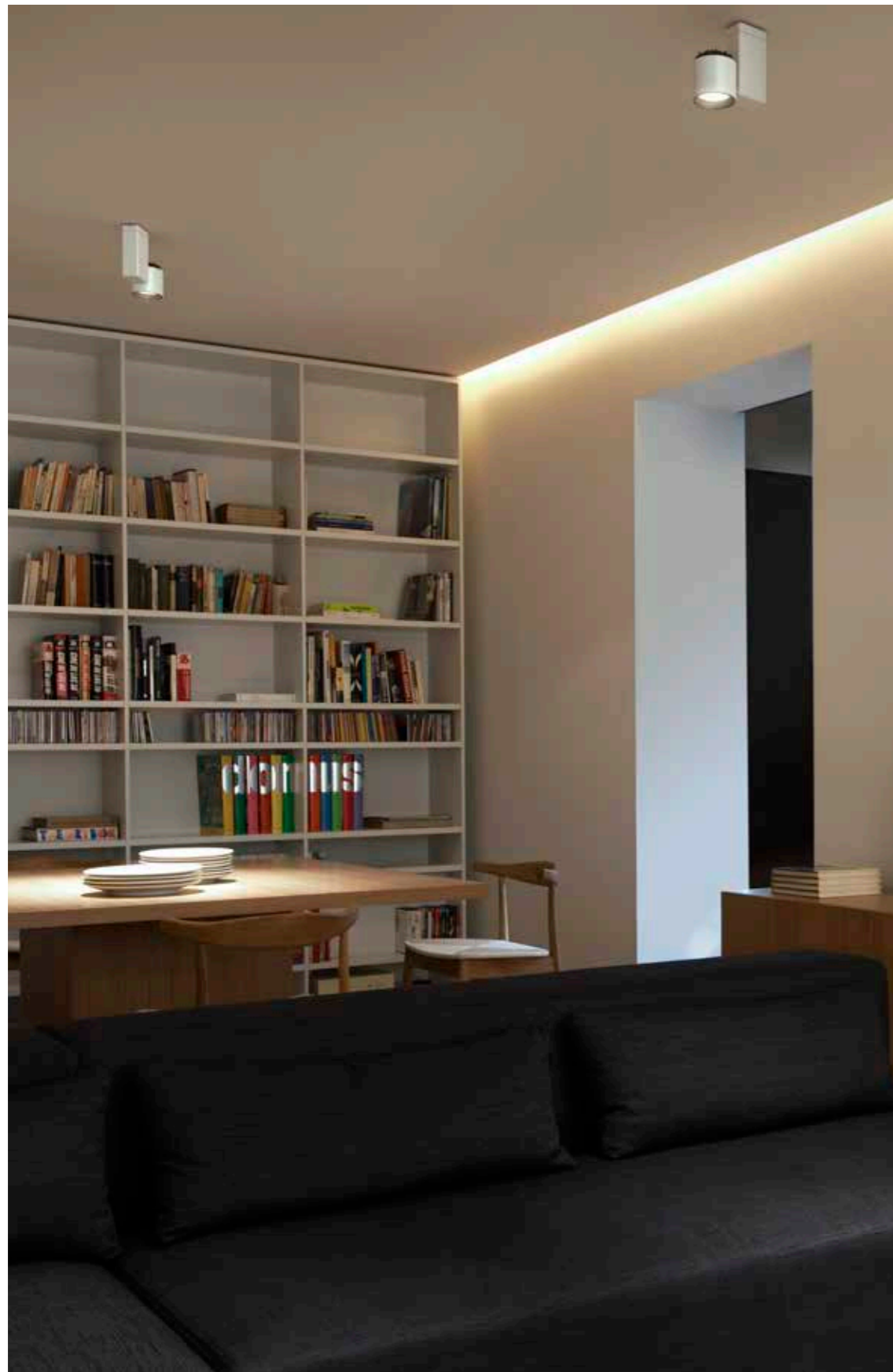

FORT KNOX

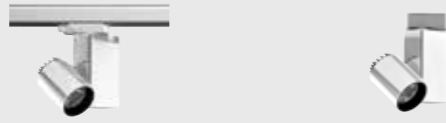

LED ARRAY
9,2W
13,8W

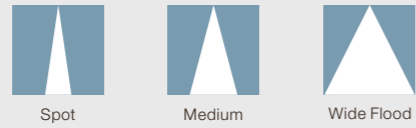

09, 30 Weiss
09, 30 White

50, 05 Hochglänzendes Aluminium
50, 05 Polished Aluminium

30, 14 Schwarz
30, 14 Black



Drehbar um 355° und schwenkbar 95°.
Can be rotated 355° and swivelled 95°.

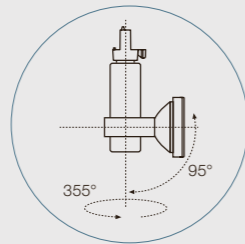

FORT KNOX WALL LED



POWER LED
32W

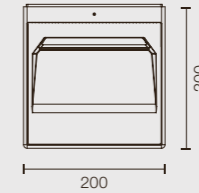

40 Weiss
40 White

05 Hochglänzendes Aluminium
05 Polished Aluminium

14 Schwarz
14 Black

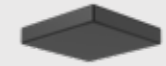

Kompakte Leuchtenfamilie für den Wandeinbau mit LED-Leuchtquellen. An ein einziges Standard-Einbaugehäuse, in dem sich die Elektronik befindet, lässt sich bequem jede beliebige Leuchte der Serie, die alle äußerst kompakt sind, anschließen.

WALL SYSTEM

Range of small, LED lighting devices designed for wall mounting. Any of the fittings in the range can be coupled, all being extremely small in size, with the single recessed standard casing containing the lamp's electronics.





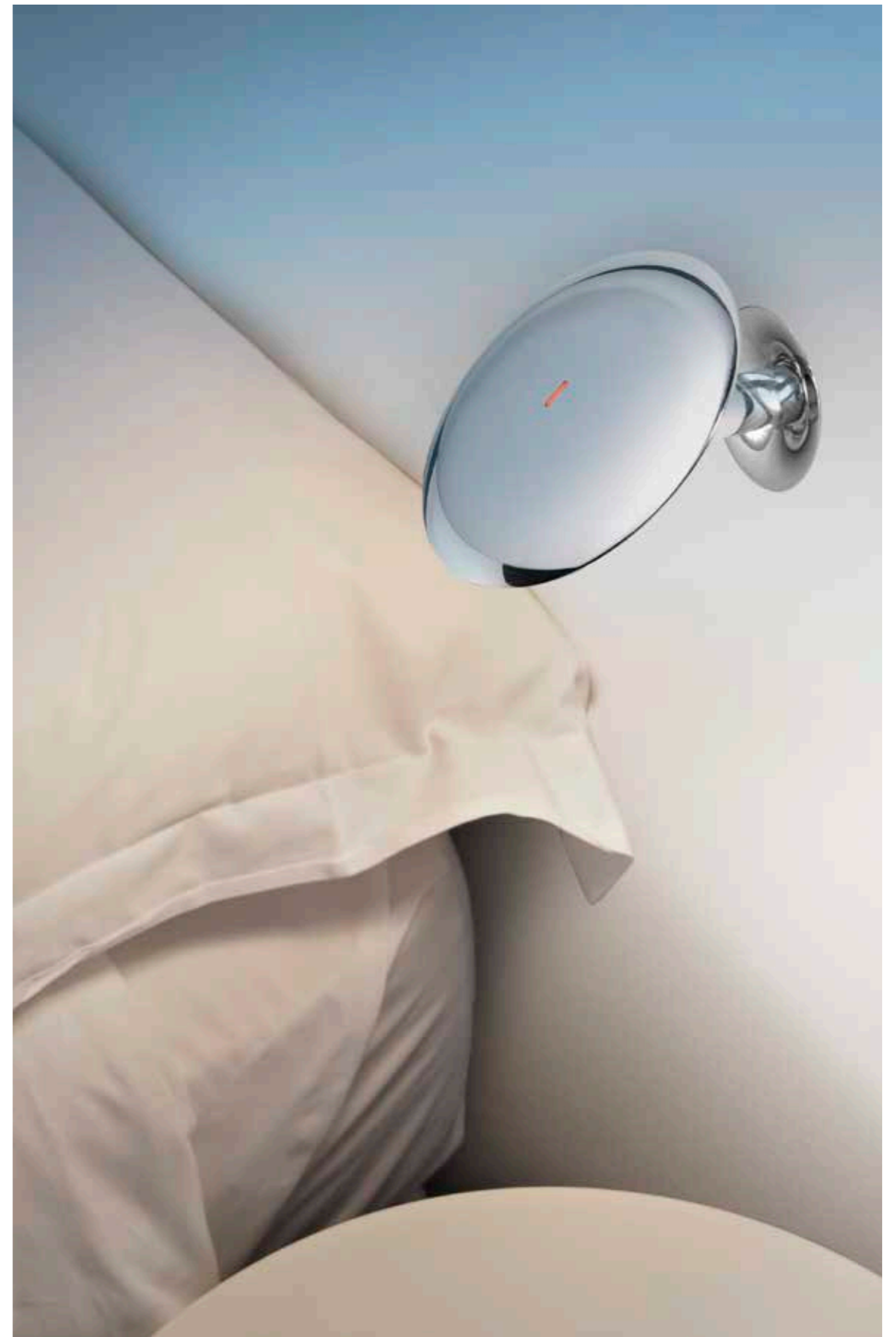
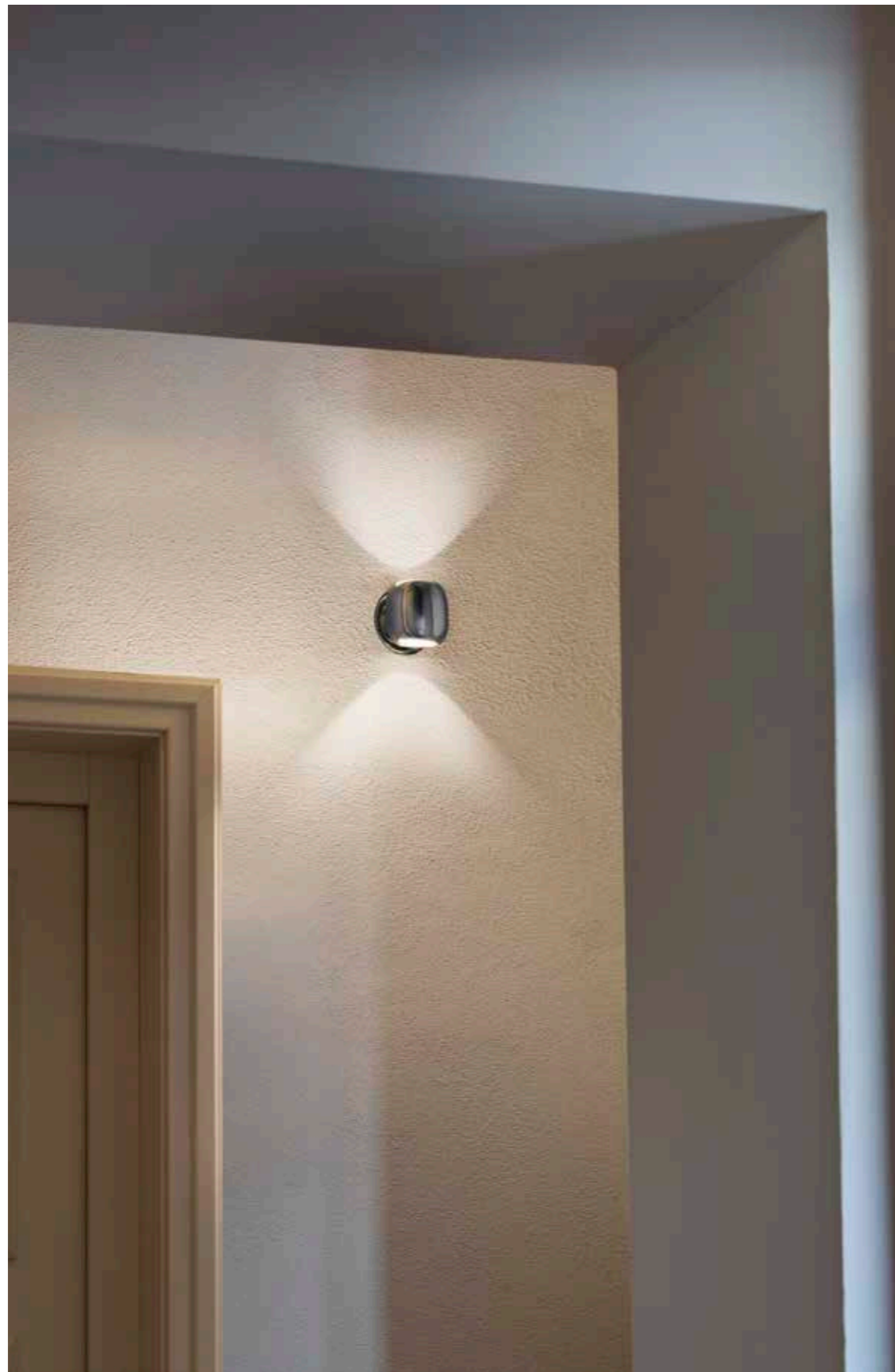

WALL SYSTEM

BACK 1



BACK 1
OPTIMAL
SWITCH



BACK 2



UP&DOWN



TOP LED
6W

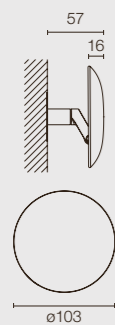

TOP LED
OPTIMAL
SWITCH

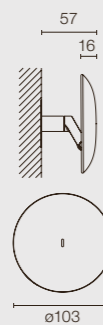

TOP LED
8W

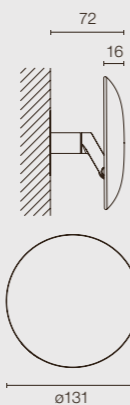

POWER LED
4W

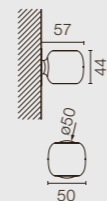

■ 57 Chrom
57 Chrome



Drehbar um 360° und schwenkbar 120°.
Can be rotated 360° and swivelled 120°.

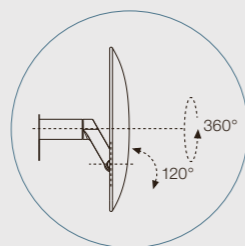

WALL SYSTEM

MINIKELVIN
WALL FLEX



MINIKELVIN
FLEX



TOP LED
4W

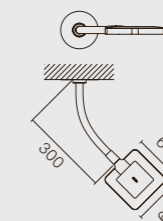
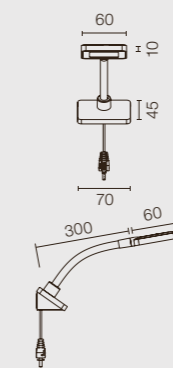

□ 09 Weiss
09 White



■ 57 Chrom
57 Chrome



■ 30 Schwarz
30 Black



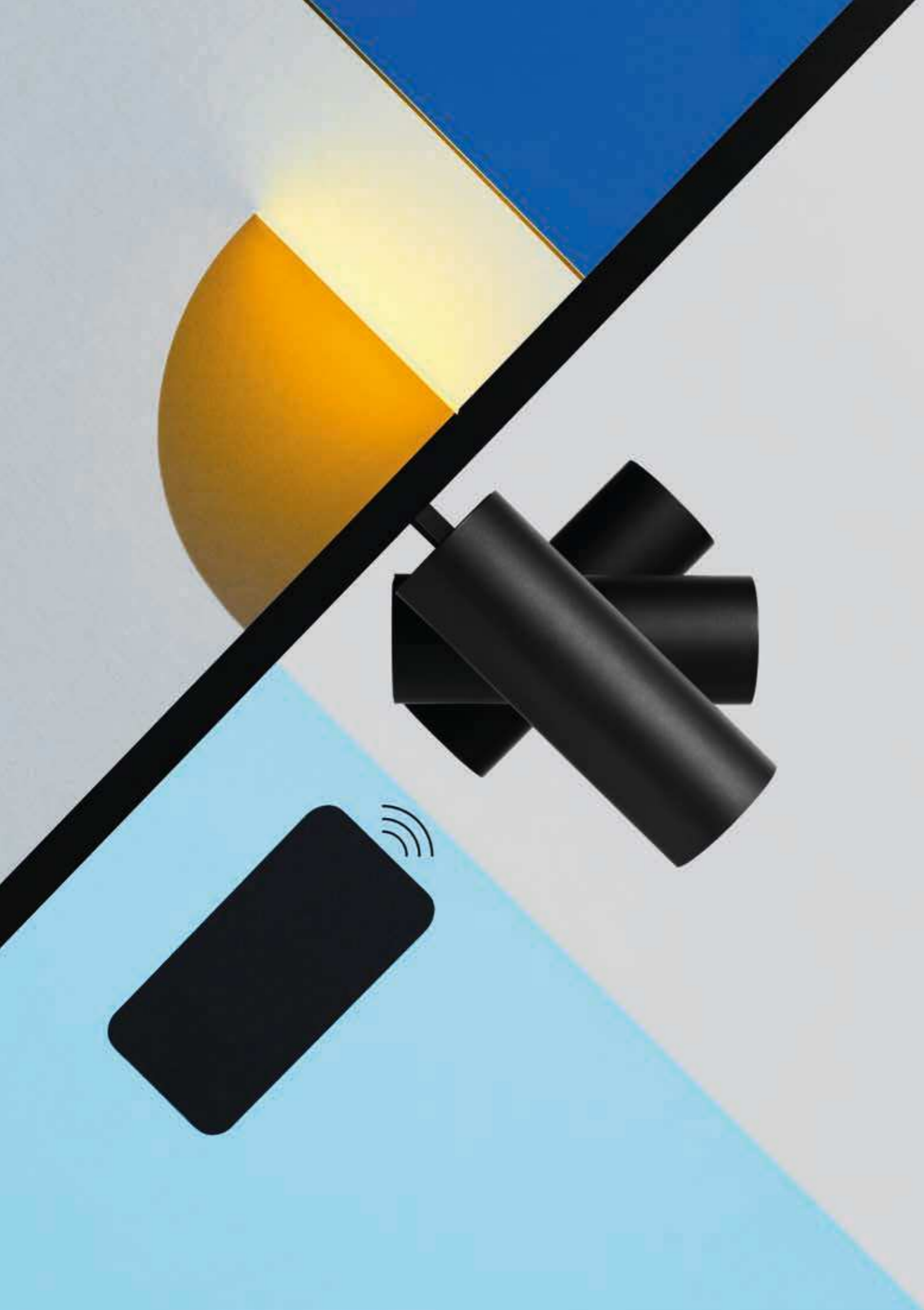

THE FAST TRACK

Weltweit einziges System, das motorisierte Projektoren entlang einer Struktur bewegen und orientieren kann. Hocheffiziente Versionen mit Superspot- bis Floodoptiken. Einfache Bedienung mit dem exklusiven FLOS SMART CONTROL®.

THE FAST TRACK

Only system in the world that can move and guide motorised projectors along a structure. High efficiency versions with optics from superspot to flood. Easy handling through the exclusive FLOS SMART CONTROL®.



DESIGNED BY FLOS ARCHITECTURAL

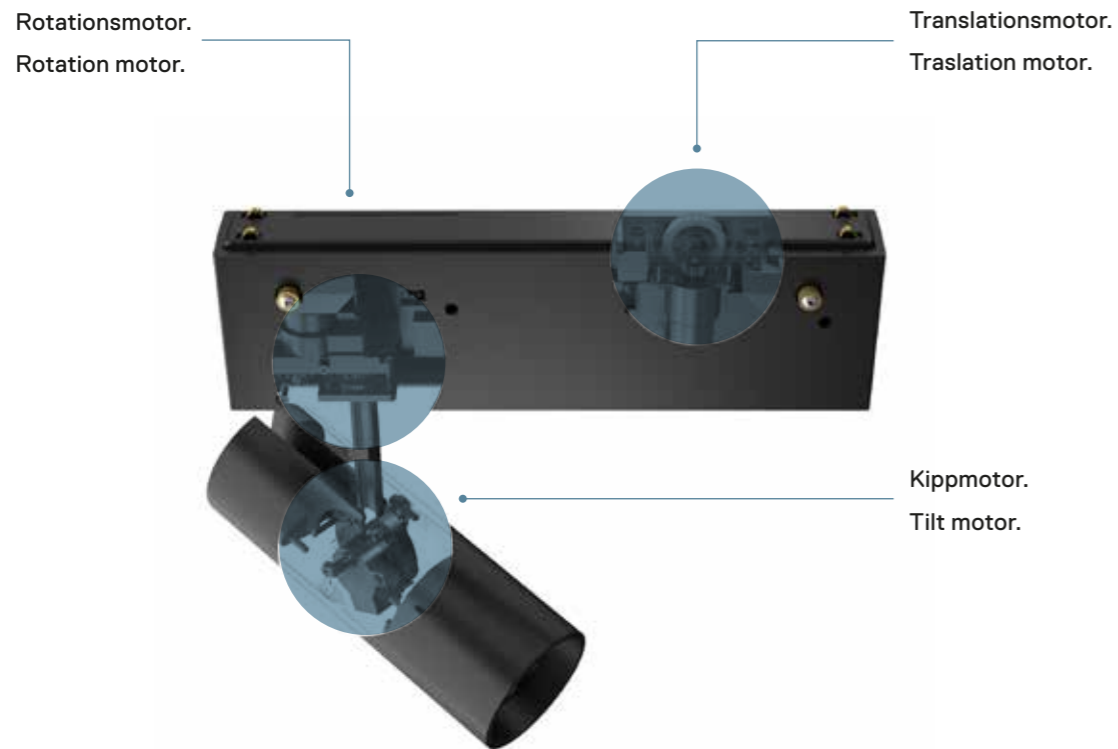

FLOS steigt auf eine noch nie vorher erreichte Ebene. Fortbewegung und Orientierung eines exklusiven Projektorsystems, das aus der Ferne mit FLOS SMART CONTROL® programmiert und gesteuert werden kann. Spitzentechnologie & einfache Bedienung.

Flos moves to an unprecedented level. Exclusive translation and orientation movement of a projector system capable of being programmed and controlled remotely with FLOS SMART CONTROL®. Extreme technology & simplicity of service.

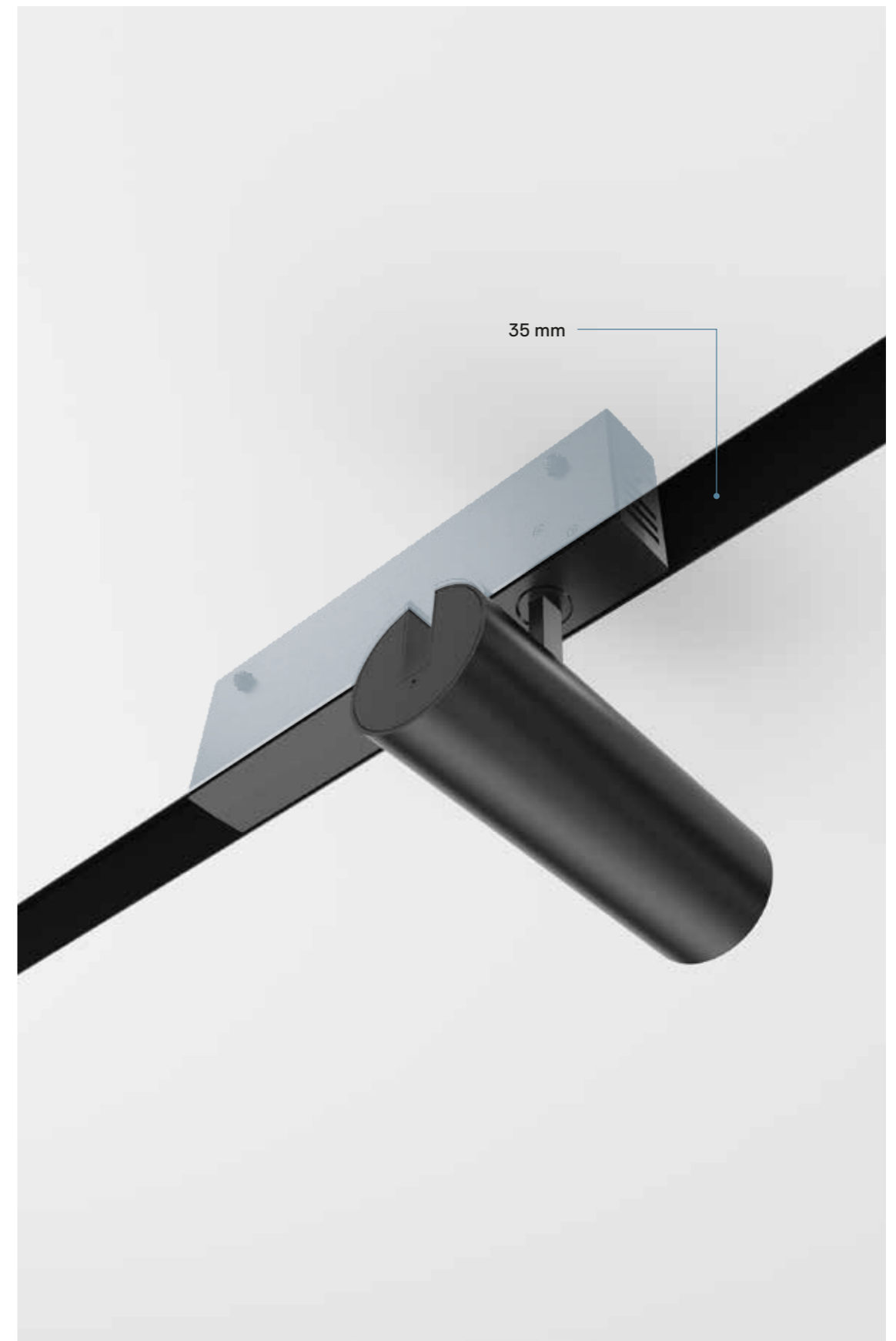

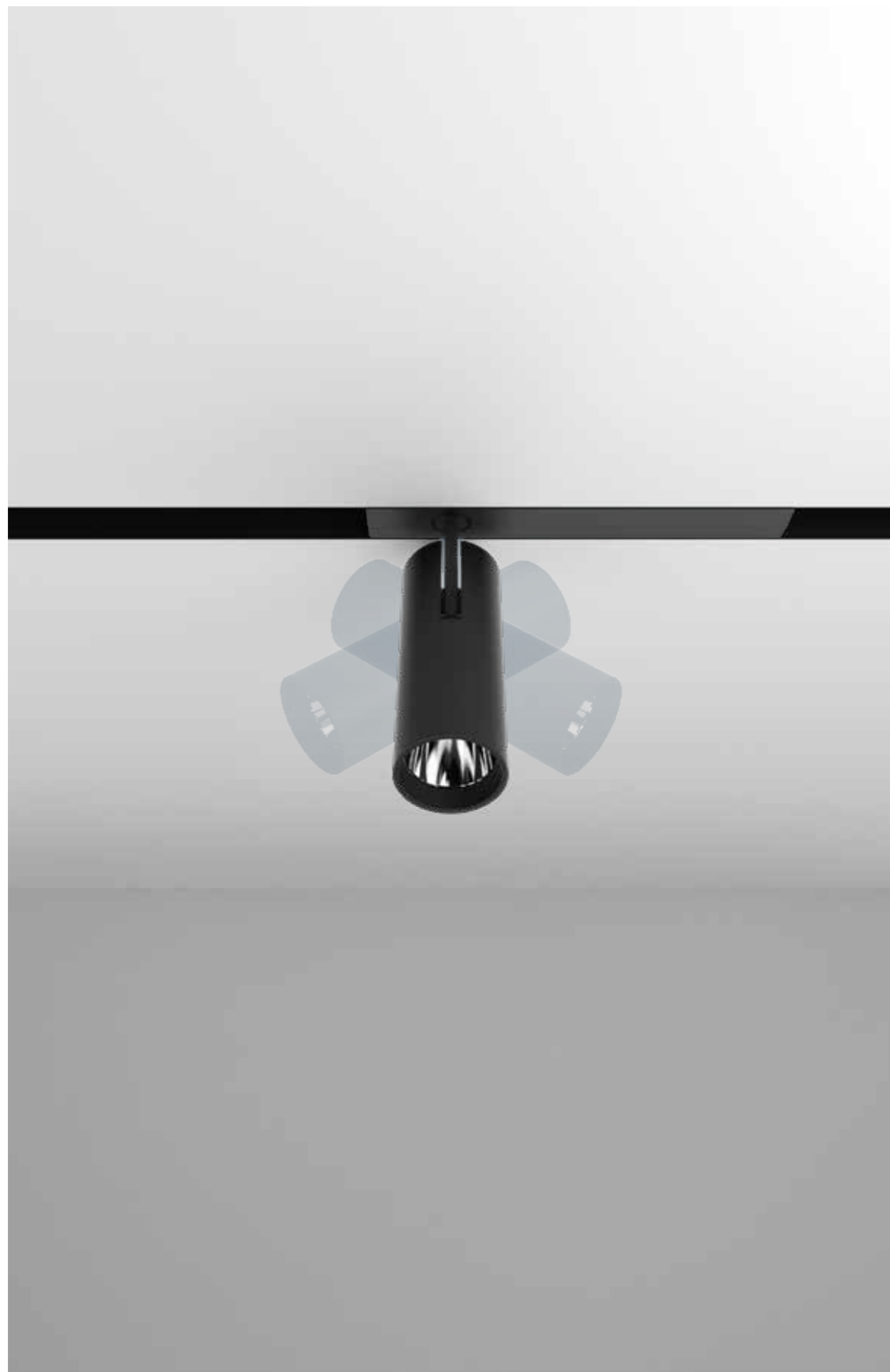

Einfache Lichtsteuerung mit der App FLOS SMART CONTROL® erhältlich für IOS und Android. Einfache Bluetooth-Verbindung zu Ihrem Gateway.

Easy light control from the FLOS SMART CONTROL® application available for IOS and Android. Friendly interface with bluetooth connection to your Gateway.





Ein revolutionäres Produkt, das die Steuerung in den drei Achsen erlaubt: Rotation, Kippen, Translation.

Revolutionary product that allows movement management in the three axes: rotation, tilting and translation.

Eine ganze Auswahl von professionellen Strahlern: verschiedene Leistungen und Superspot bis Flood Optiken.

A complete range of professional spotlights: various power options, and optic from super spot to flood.

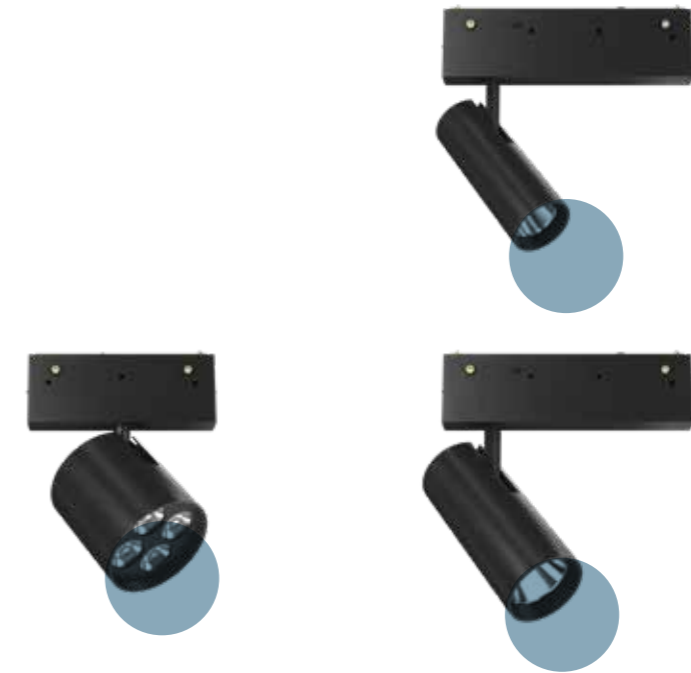

THE FAST TRACK 100

THE FAST TRACK 150 / 175



Positionsschalter.
Limit switch sensor.



Optischer Sensor, der jederzeit die Spotposition im Profil erkennt.
Optical sensor that detects the spot position in the profile at any time.

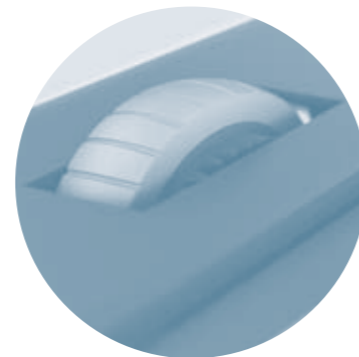

Gummilager mit Stoßdämpfer, der einen ständigen Kontakt mit dem Profil für eine hervorragende Translation gewährleistet.
Rubber bearing equipped with a shock absorber that ensures constant contact with the profile for an excellent translation.



Mehrlinsenoptik mit Winkeln von bis zu 4 Grad sind erhältlich. Beleuchtungsszenario erstellen.
Versions with high-efficiency multi-lens optics with up to 4-degree angles are available.

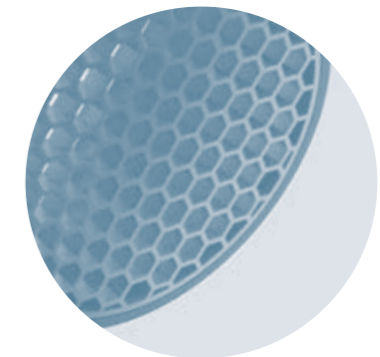

Honeycomb-Zubehör für eine perfekte Sichtkontrolle und Abschirmung.
Honeycomb accessory for a perfect visual control and shielding.

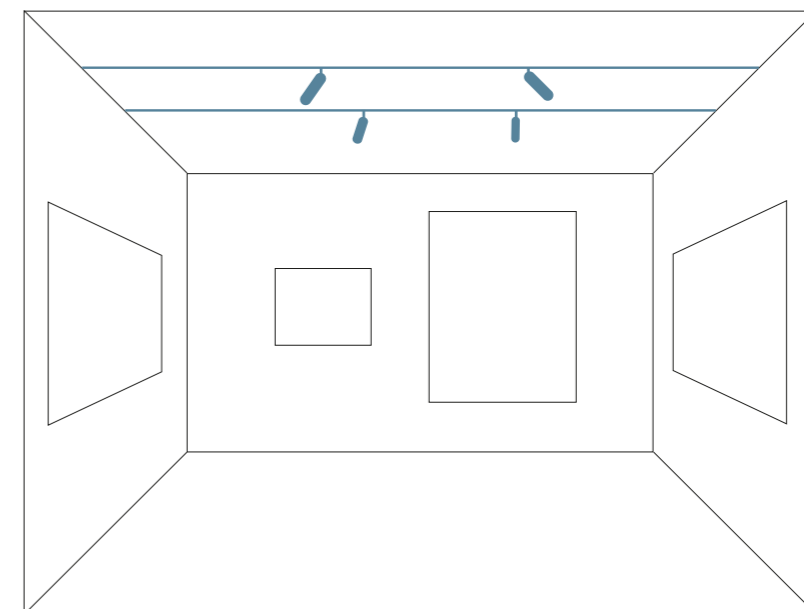
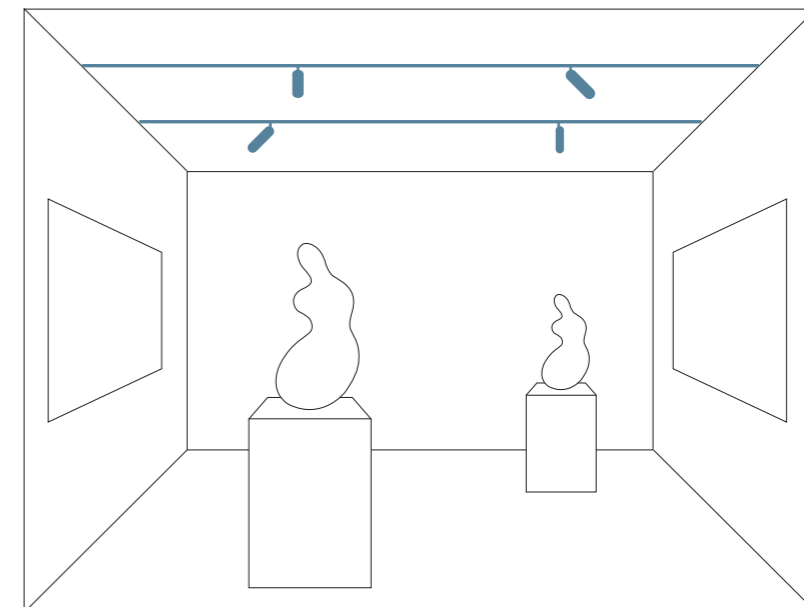
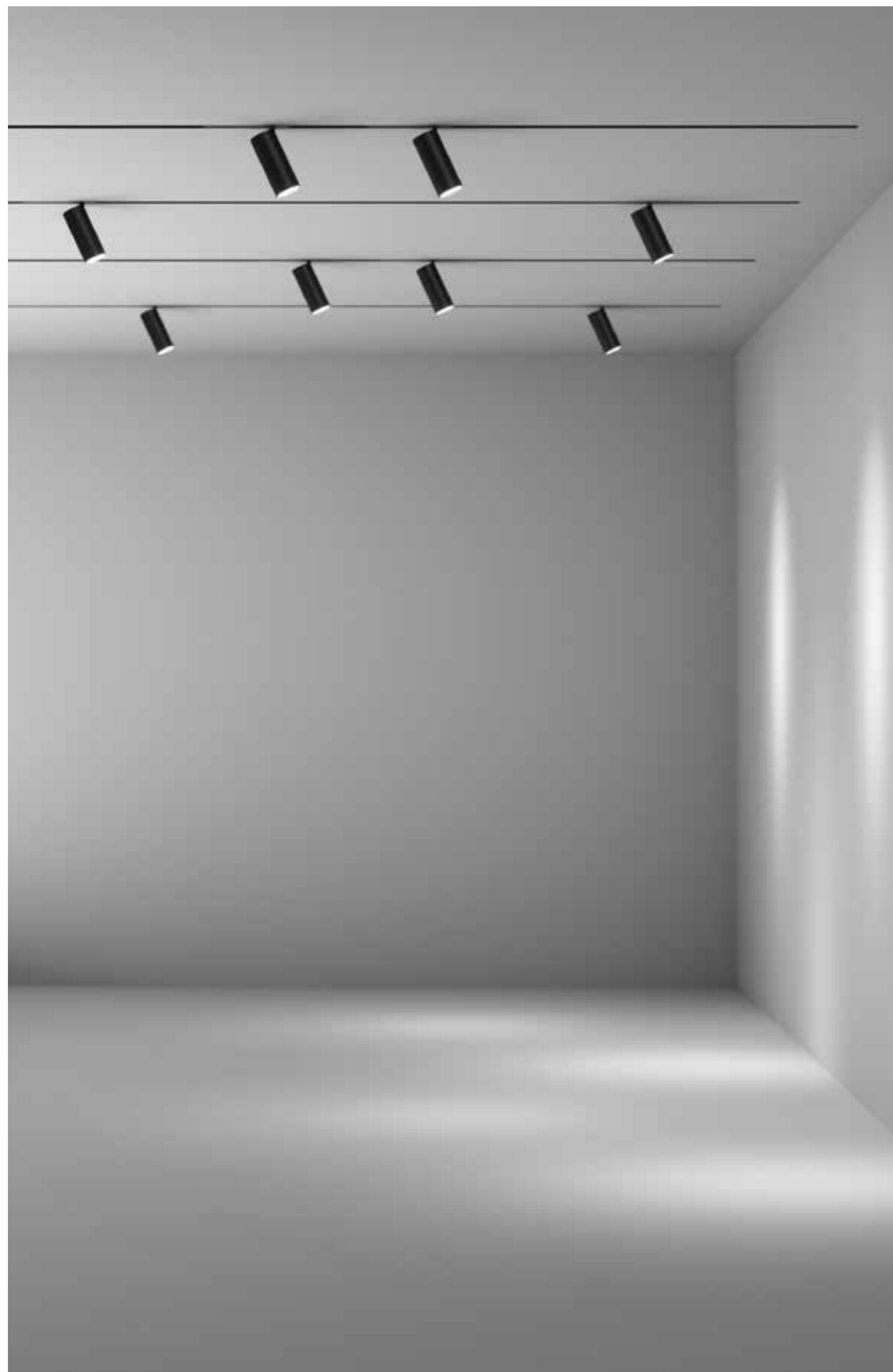

Dank der App können Sie jede Leuchte einrichten, all deren Positionen und Voreinstellungen speichern und ein individuelles Beleuchtungsszenario erstellen.

Thanks to the application you can set up each luminaire, save all their positions and presets and generate a lighting scenario.

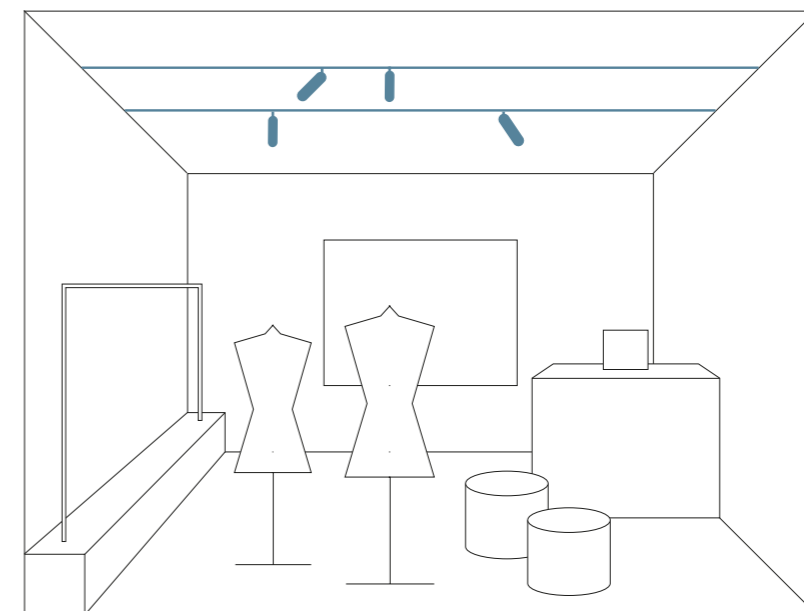
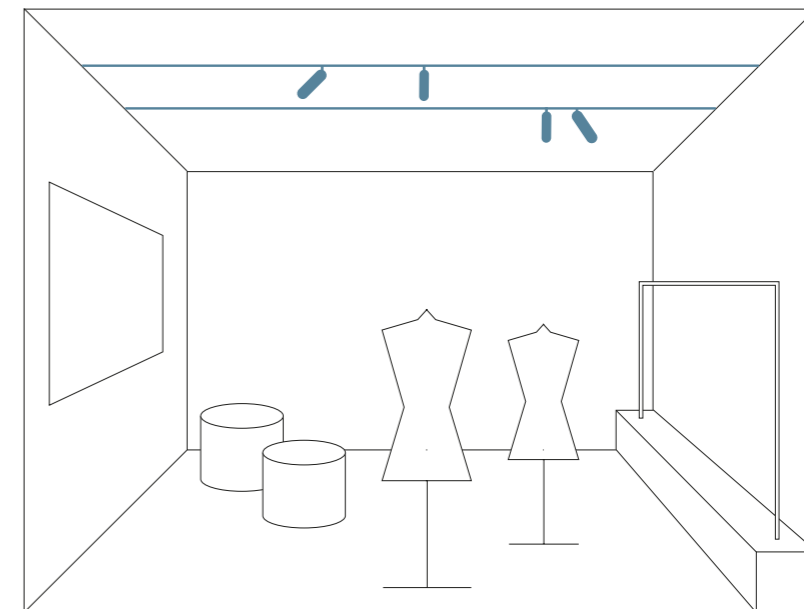
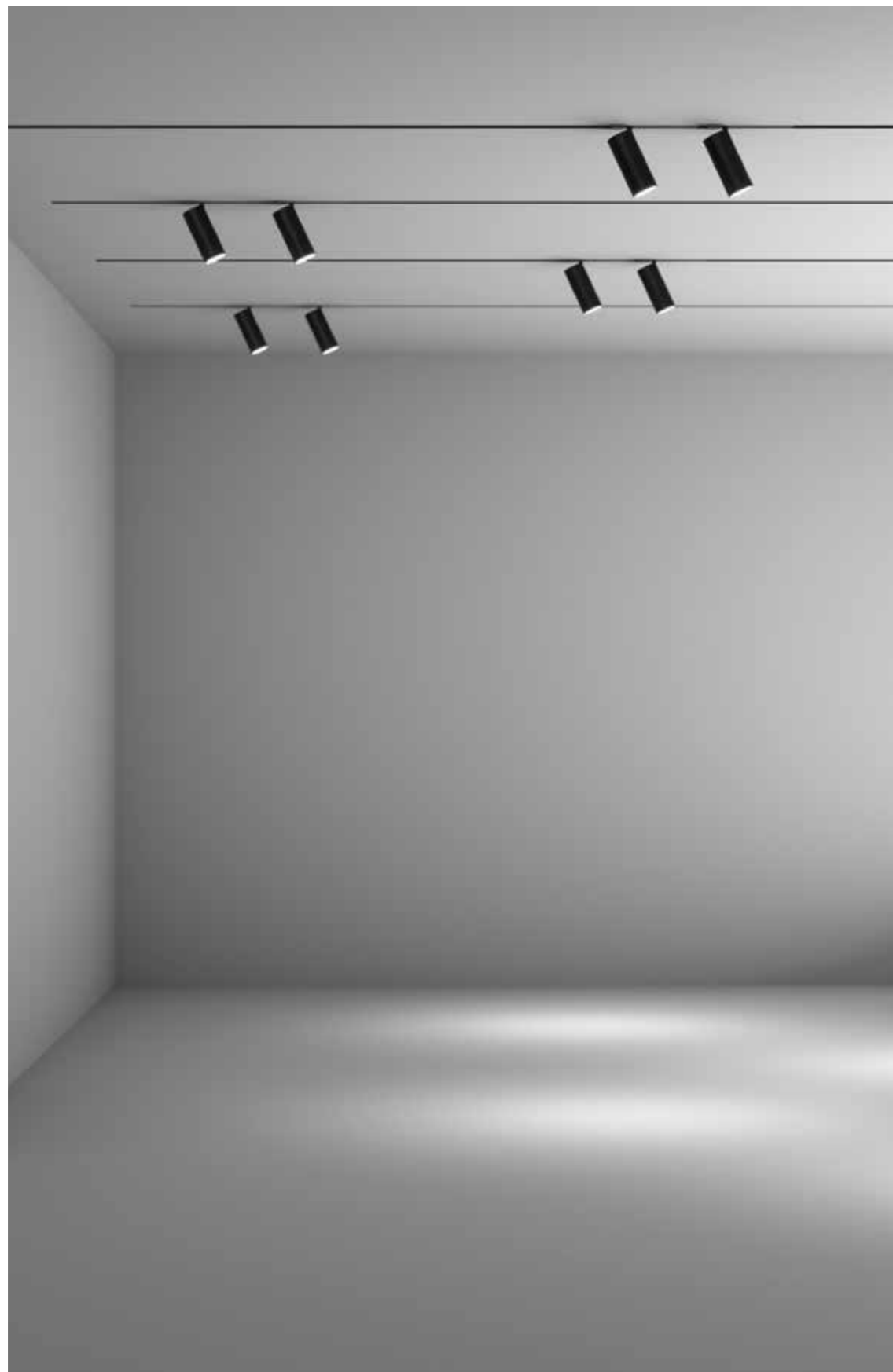

Die App bietet auch die Möglichkeit von Szenario und Verwaltung und geplante Aktivierung.

The application also offers the possibility of scenario management and scheduled activation.

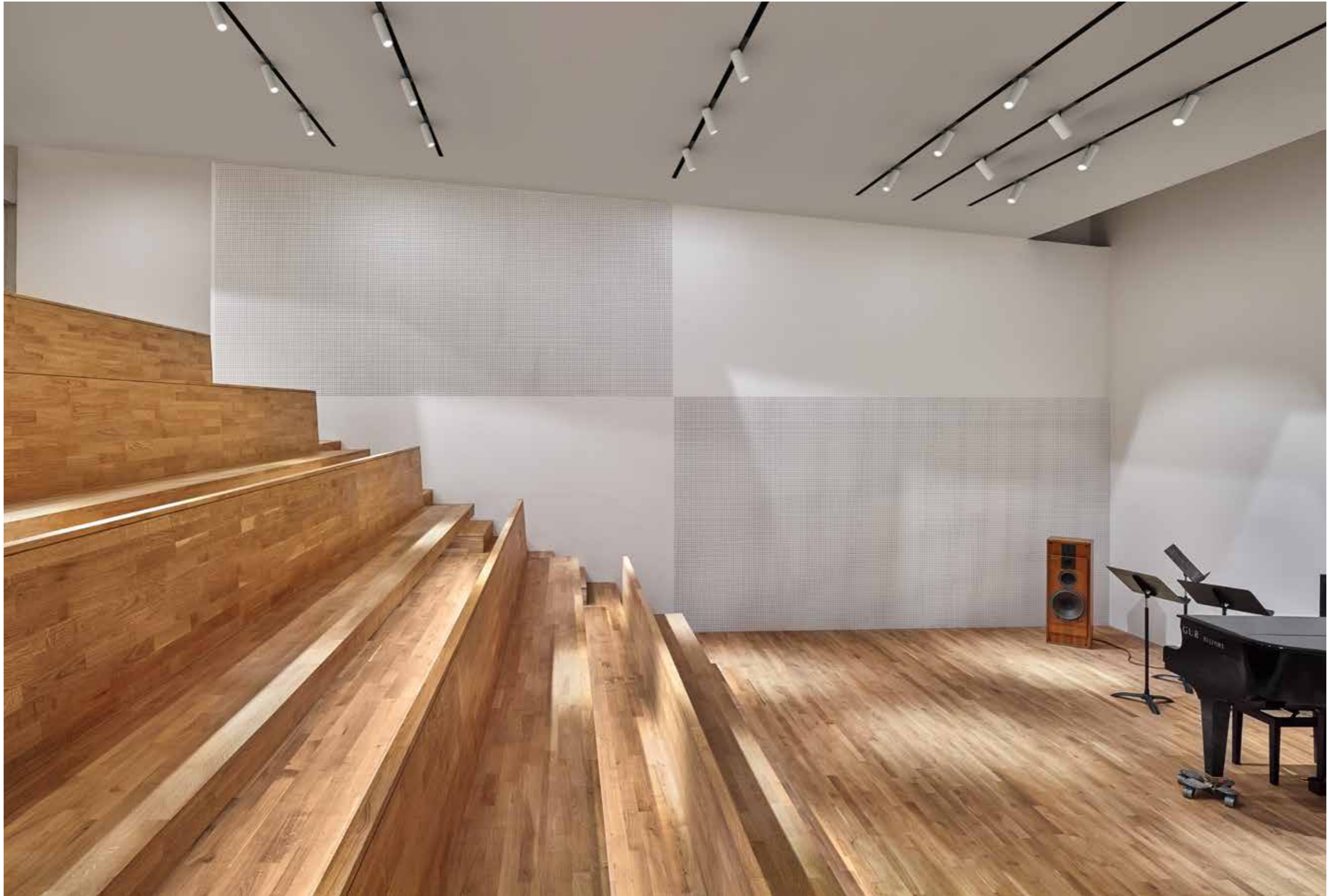

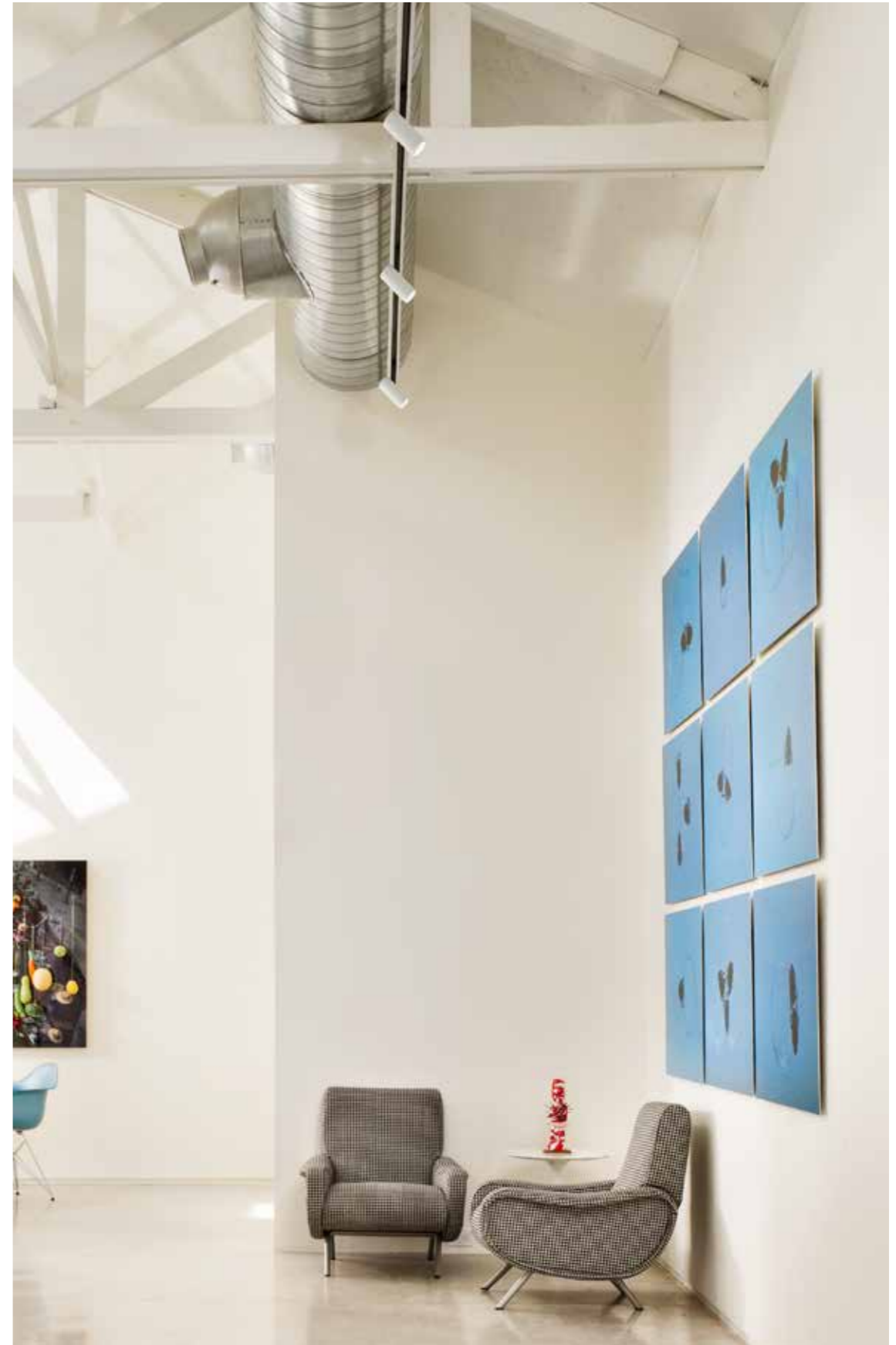

LIGHT MODULES



THE FAST TRACK 100



POWER LED
13W

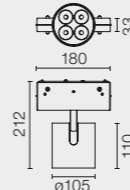

THE FAST TRACK 150



LED ARRAY
25,5W

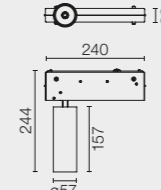

THE FAST TRACK 175



LED ARRAY
38,5W

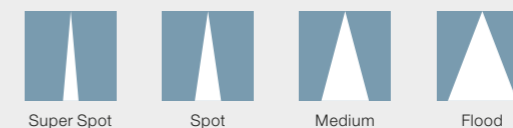
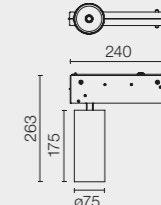

RECESSED

■ 14 Schwarz
■ 14 Black



SURFACE

□ 40 Weiss
□ 40 White ■ 14 Schwarz
■ 14 Black



Gehäuse / Box
Kopf / Head

□ Weiss / White
□ Weiss / White

■ Schwarz / Black
■ Schwarz / Black

■ Schwarz / Black
□ Weiss / White



Die Anschlussdose ist in der Einbauvariante bündig, während sie in der Oberflächenvariante über das Profil hinausragt.
Für die Installation auf dem Profil recessed empfehlen wir stets die Leuchten mit dem schwarzen Gehäuse.
Für die Installation von weißen Leuchten auf dem Profil surface empfehlen wir die Ausführungen, bei denen das Gehäuse dasselbe Dekor hat wie das Profil.

The junction box ends up flush in the recessed version while in the surface version it protrudes from the profile.
For installation on the recessed profile, we always recommend that you choose luminaires with a black box.
To install white luminaires on the surface profile, we recommend that you choose versions with a box in the same colour as the profile.

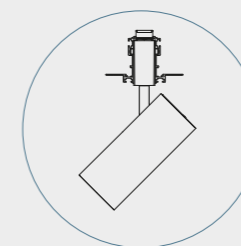

Recessed Profile

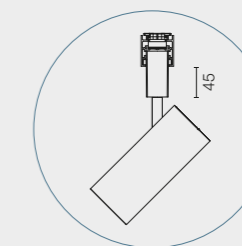

Surface Profile



FIND ME

Innenraumstrahler mit LED-Lichtquelle. In drei Versionen erhältlich: Die Version Mono Point besteht aus einem ausfahrbaren zylinderförmigen Körper, der eingefahren als Downlight dient und ausgefahren zu einem schwenkbaren Strahler wird, die Double Point Version besteht aus einem Einbaurahmen, in dem zwei Strahler untergebracht sind und Suspension Ausführung.

FIND ME

Interior lighting spotlight with LED light source. Available in three versions: Mono Point version, consisting of a removable cylindrical housing which, in its upper position, acts as a downlight, and in its lower position, becomes a directional spotlight, Double Point version, consisting of a recessed box which houses two spotlights and a Suspension version.



DESIGNED BY JORGE HERRERA

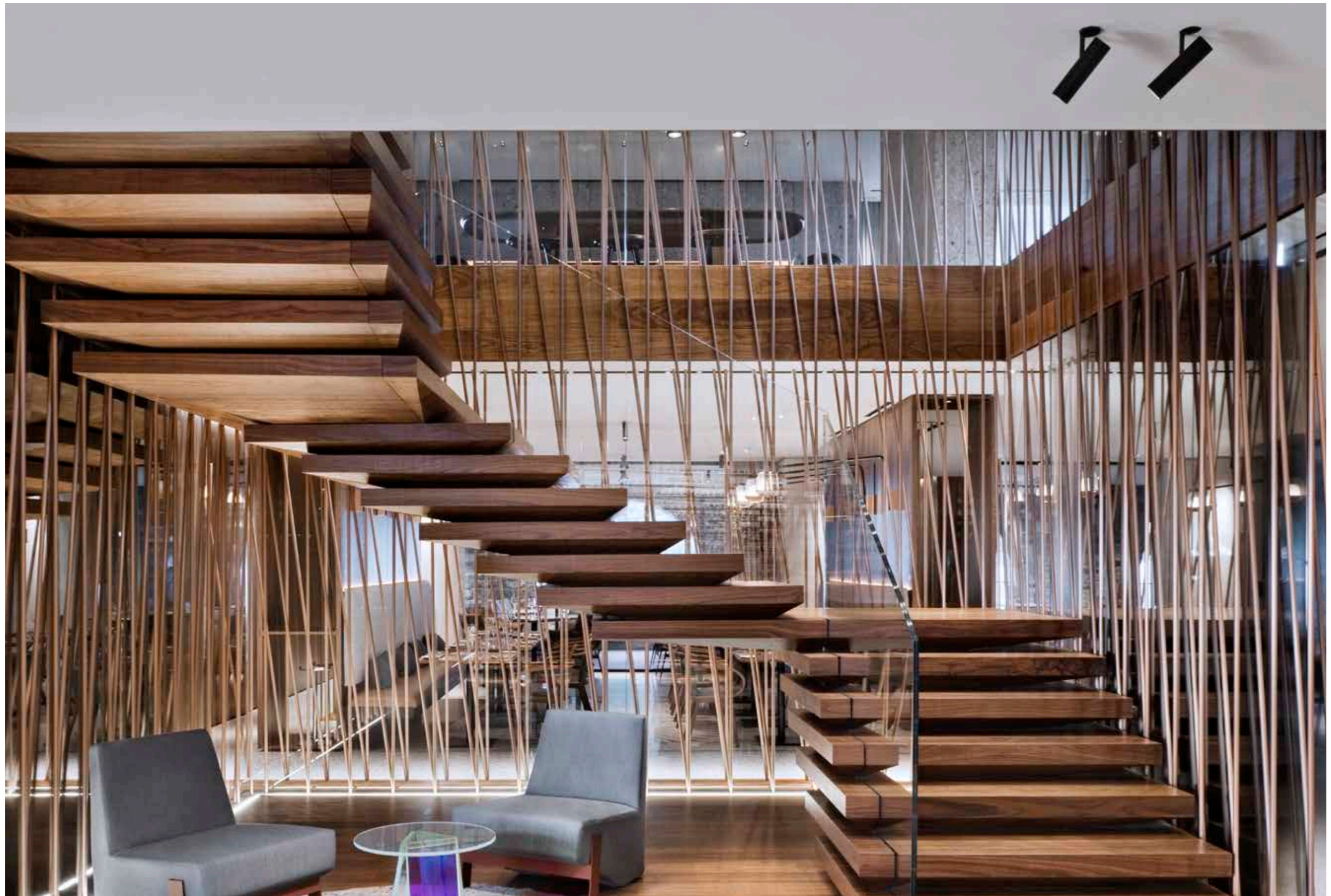

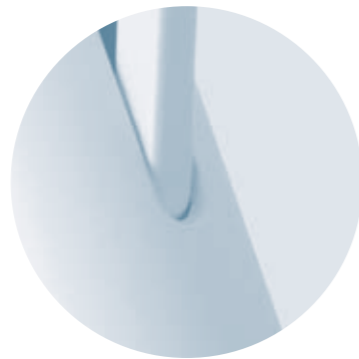

Ausrichtbar und schwenkbar dank der Basis mit 360° Drehung und dem Arm aus Zamak, der sich 70° ausrichten lässt.

Directional and tilting thanks to its base with 360° rotation capacity and to its arm made of zamak, directional up to 70°.



Ein spezielles Versetzungssystem aus elastischen Nasen auf gezahnter Führung ermöglicht das Einfahren der Strahler für eine vollständige Integration in das Umfeld.

An adjustment system with elastic flanges on a toothed guide, permits concealing the spotlights, thus becoming totally integrated into the environment.

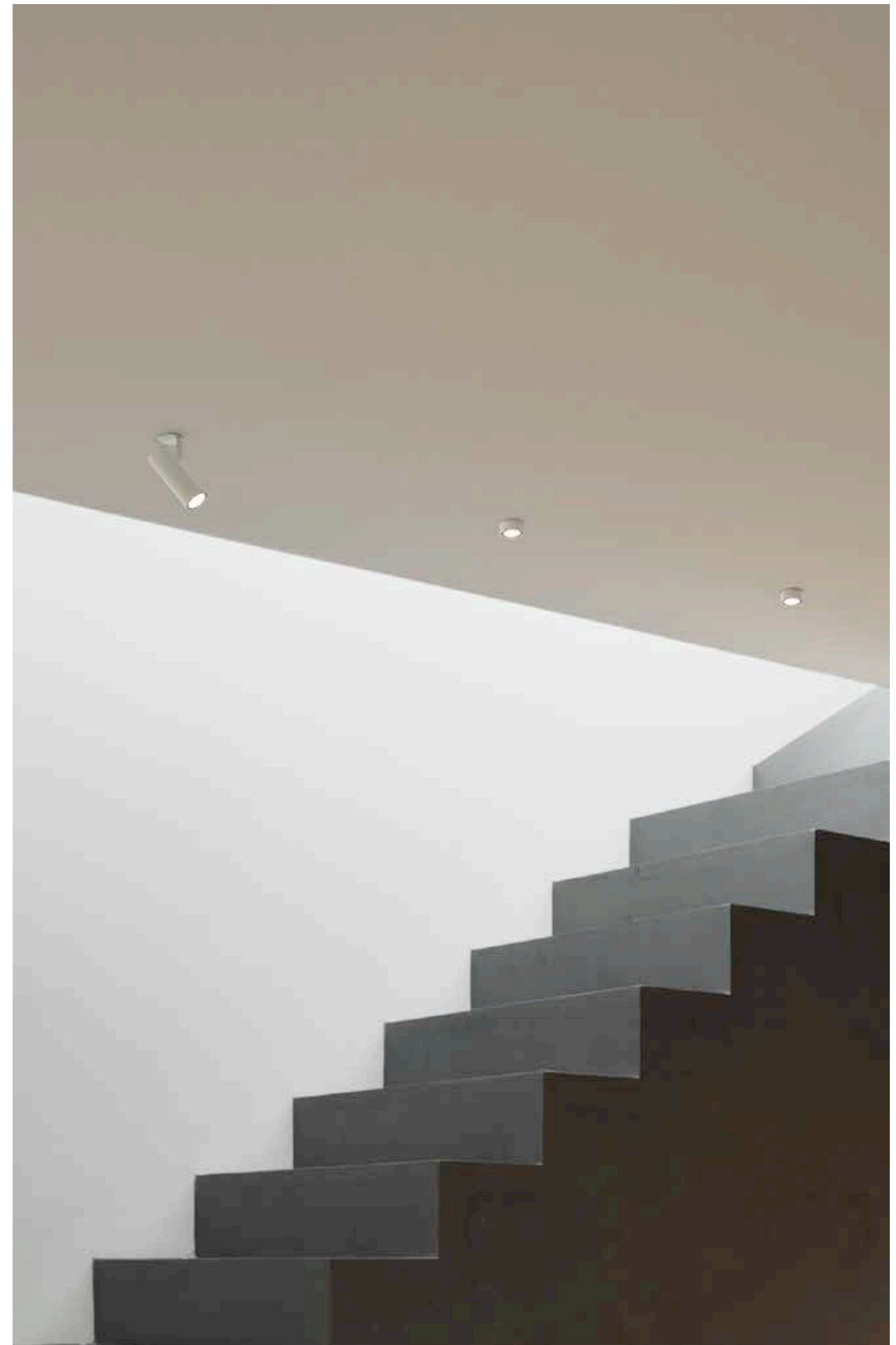

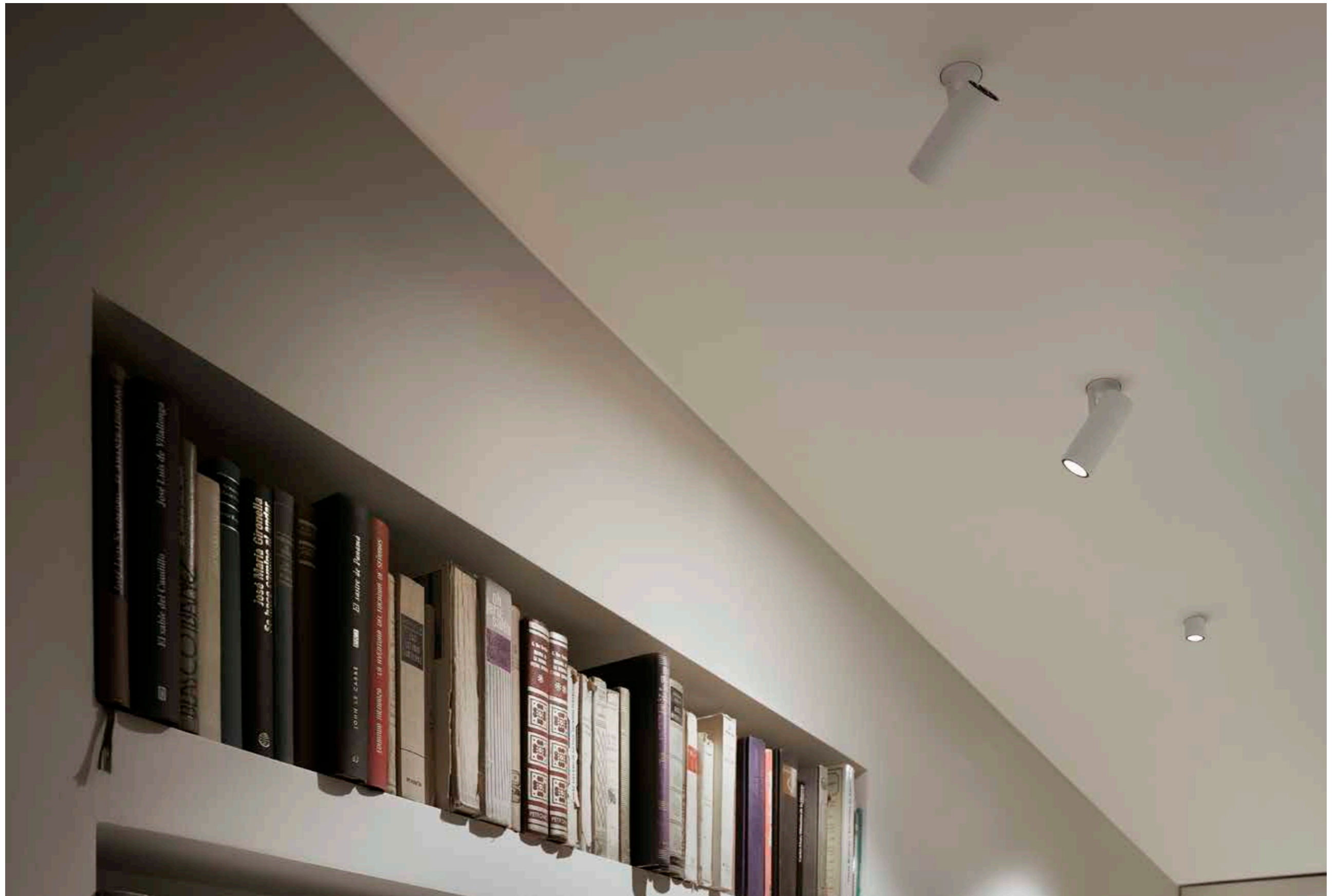

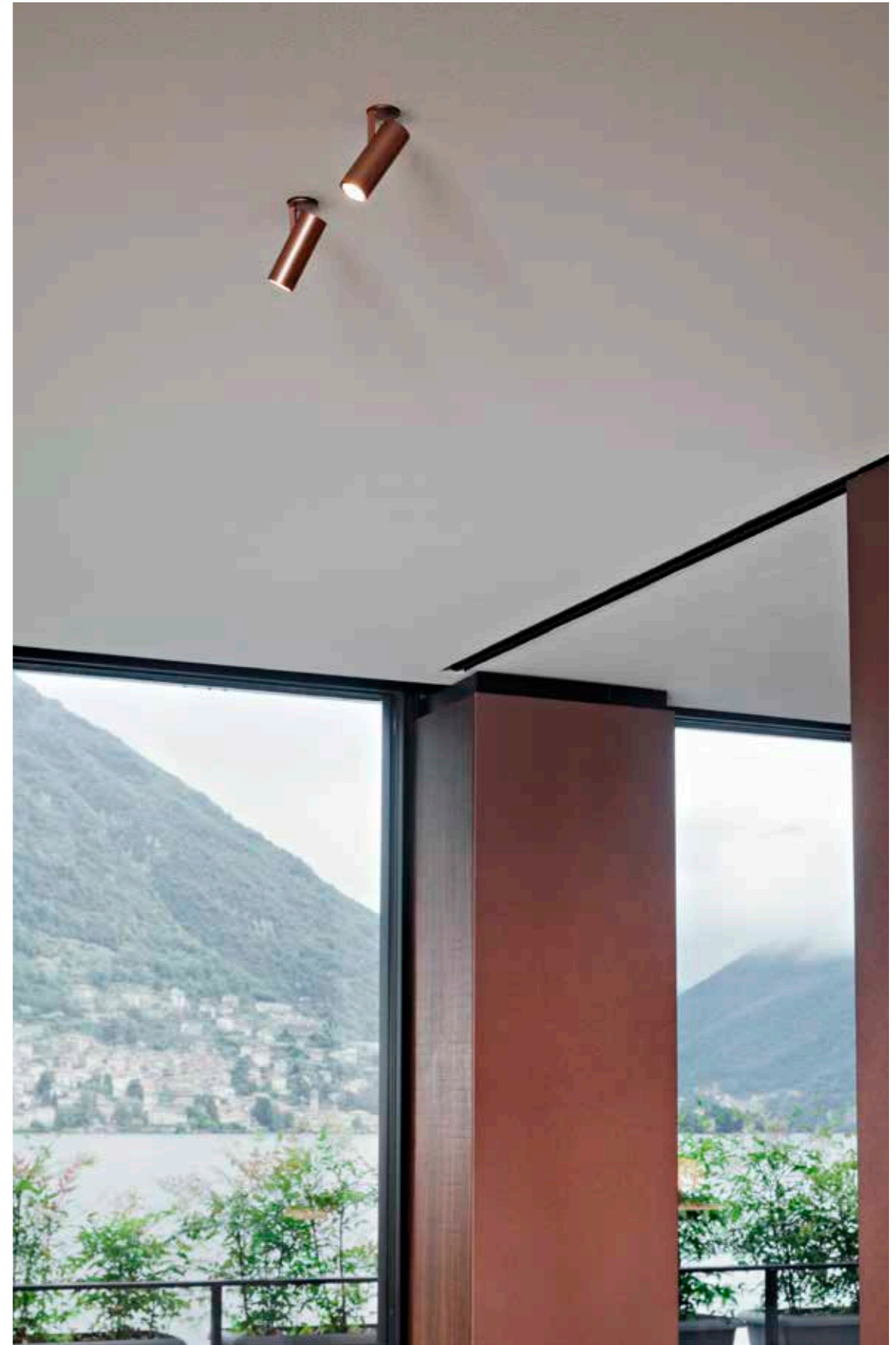

FIND ME

FIND ME ZERO
TRIM / NO TRIM

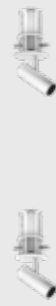

POWER LED
3W

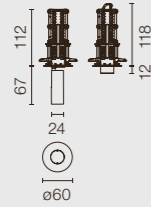

FIND ME 1
MONO POINT
TRIM / NO TRIM

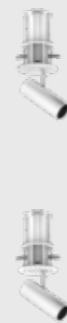

POWER LED
6W

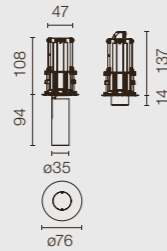

FIND ME 2
MONO POINT
TRIM / NO TRIM



POWER LED
10W

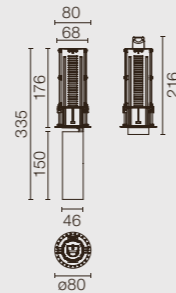

FIND ME 1
DOUBLE POINT



POWER LED
2x6W

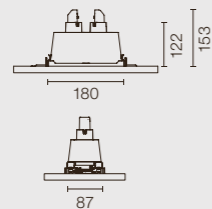

FIND ME 1
SUSPENSION



POWER LED
6W



FIND ME

Mono Point

30 Weiss
30 White

06 Chrom
06 Chrome

14 Schwarz
14 Black



Double Point



Suspension

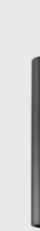

Abschirmkegel-Farben (inbegriffen)
Screening Cylinder Colours (included)

Orange
Orange

Violett
Violet

Schwarz
Black



Drehbar um 360° und schwenkbar 70°.
Can be rotated 360° and swivelled 70°.

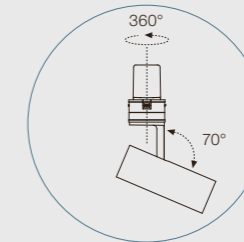

reddot design award
winner 2013

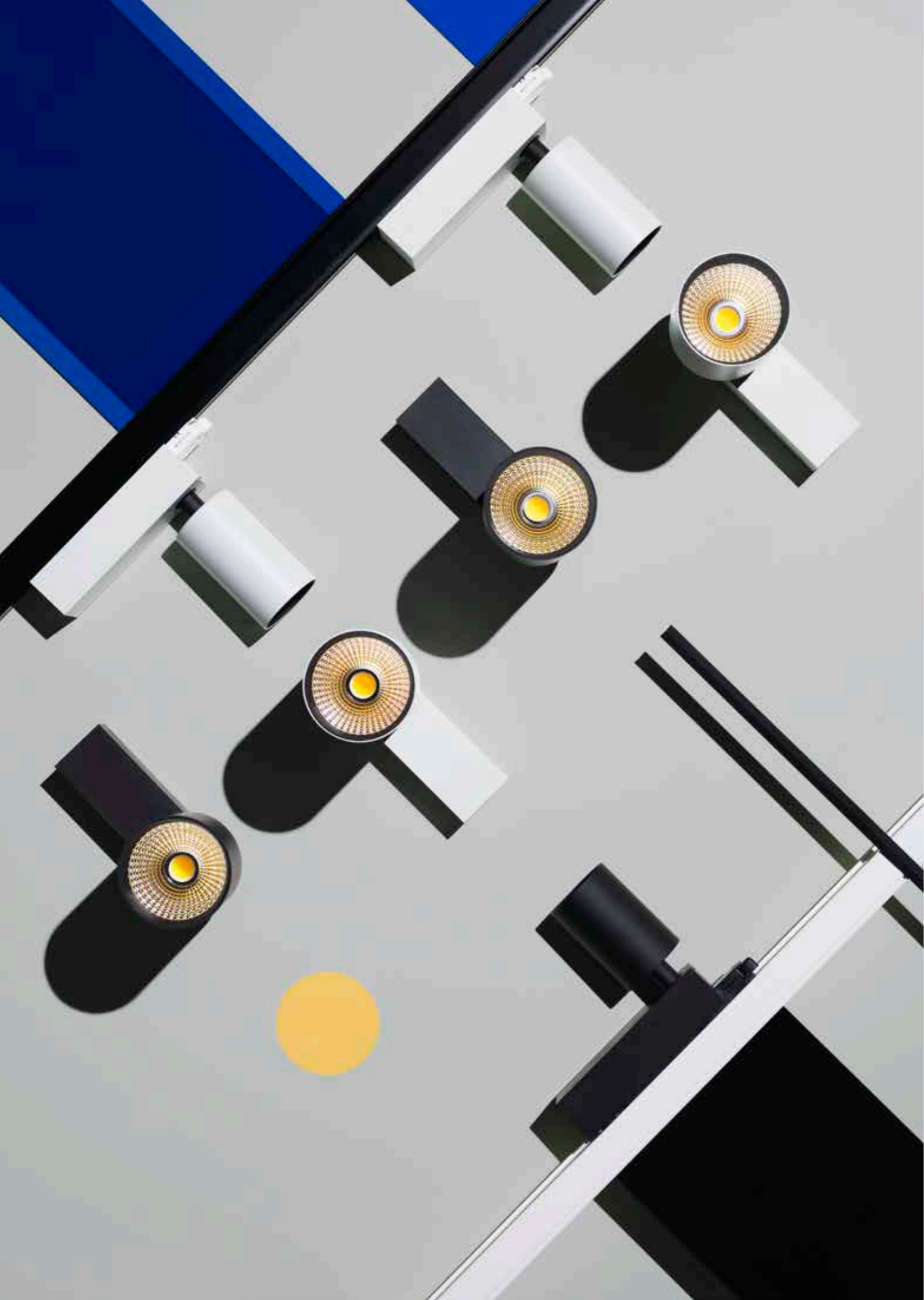

UT SPOT

Kollektion hochleistungsfähiger, eleganter LED-Strahler mit minimalistischem Design. Breite Palette an Lösungen mit Lichtquellen und Linsen, die jeden Ausleuchtungsbedarf decken. Möglichkeit zur Installation in der Dreiphasen-Schiene für höchste Flexibilität oder an der Decke zur optimalen Integration in die Architektur. Effizienz und Zuverlässigkeit.

UT SPOT

A collection of minimalist and elegant high-power LED projectors. A wide range of solutions with light sources and optics for all your lighting needs. Possibility of installing a three-phase track for maximum flexibility or ceiling installation for a better integration in the architecture. Efficiency and reliability.



DESIGNED BY FLOS ARCHITECTURAL



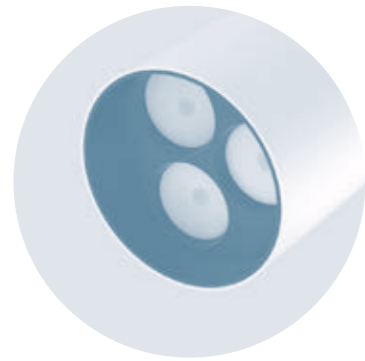

Optisches Multichip-Design, um gebündelte und gestreute Lichtstrahlen zu erzeugen.

Multichip optical design to achieve very narrow beam angles.

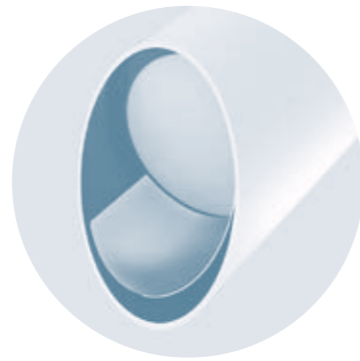

Modell Wall-Washer mit Schienenausführung Ø86 erhältlich.

A wall-washer version is available in Ø86 track version.

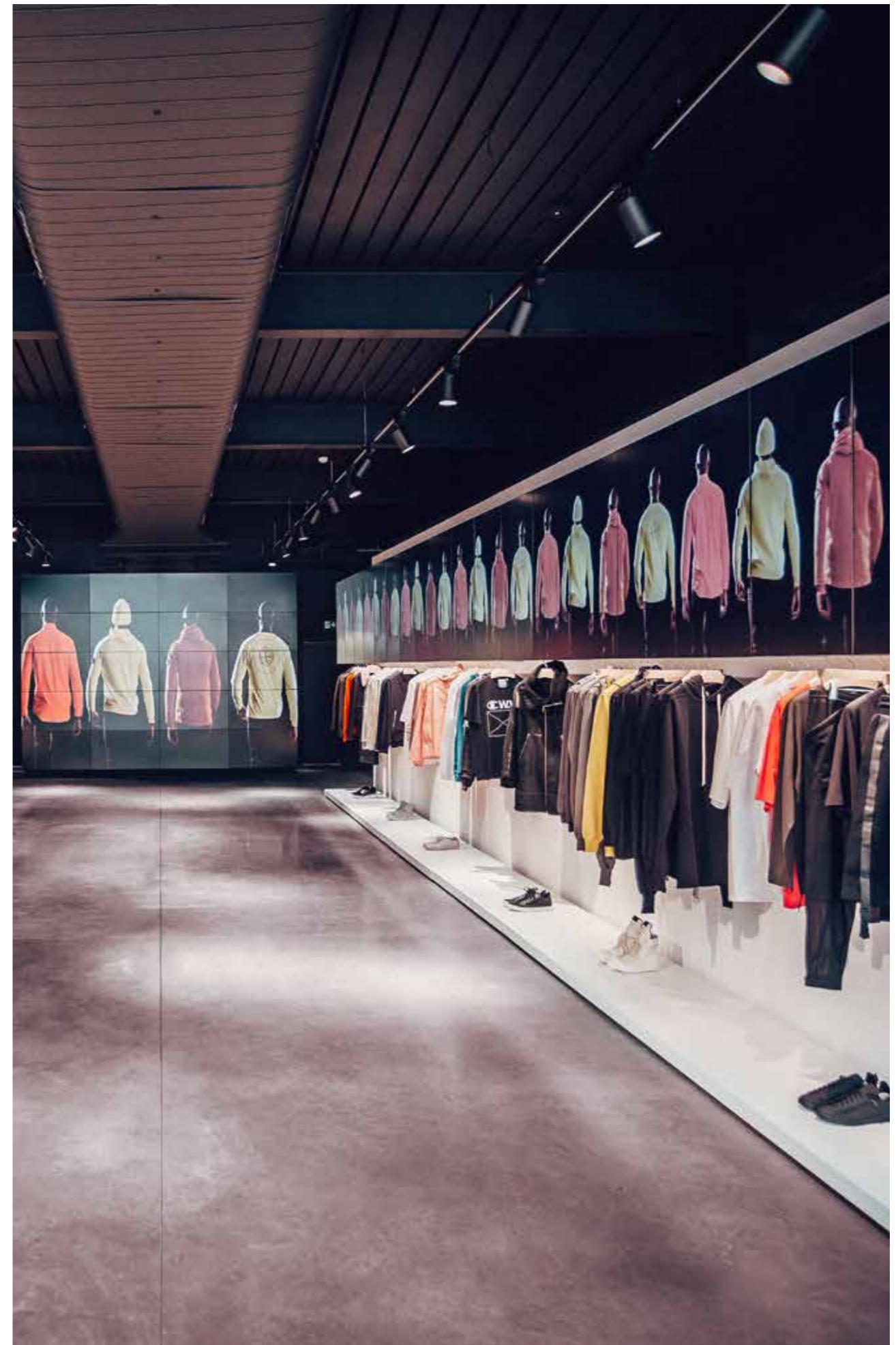

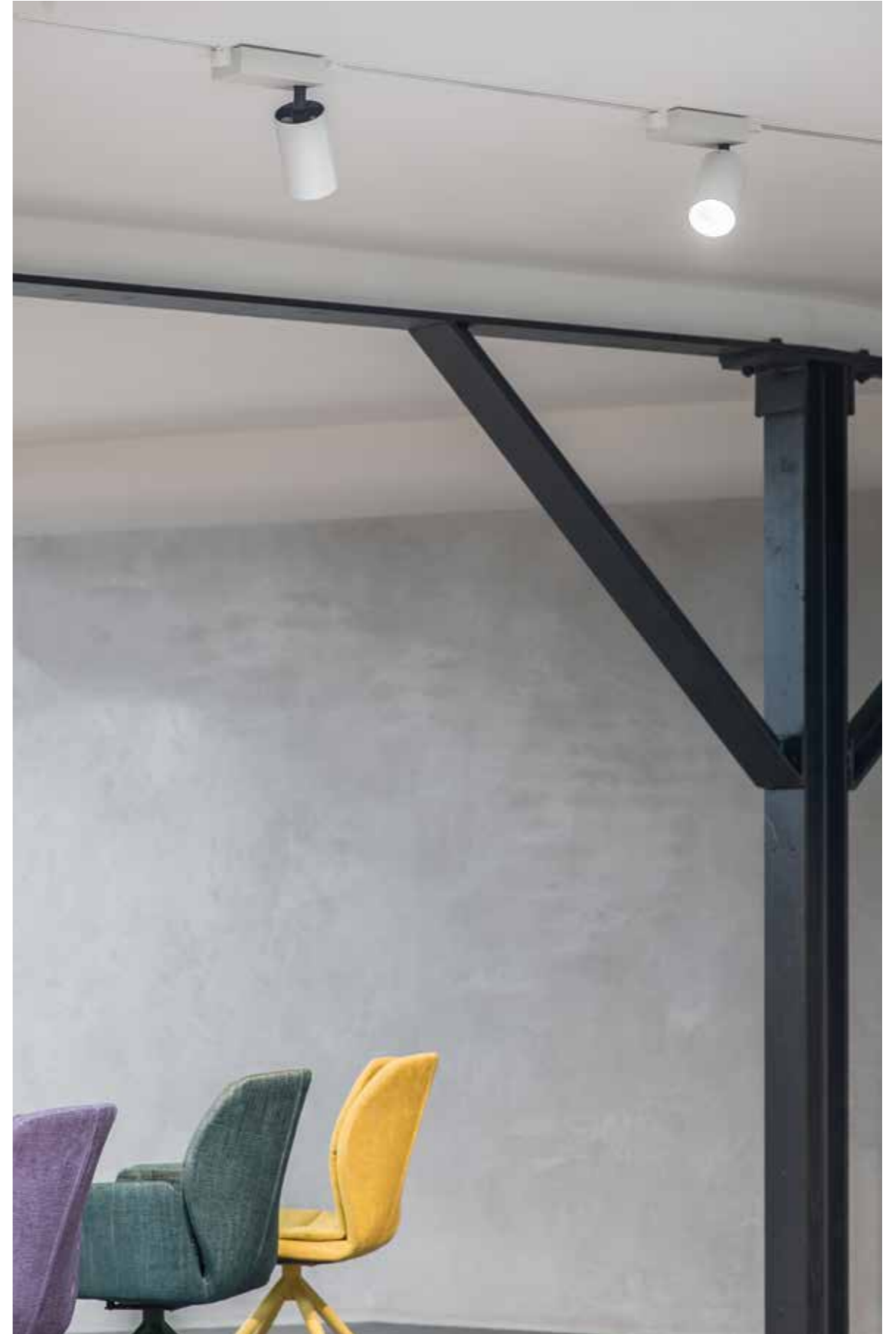



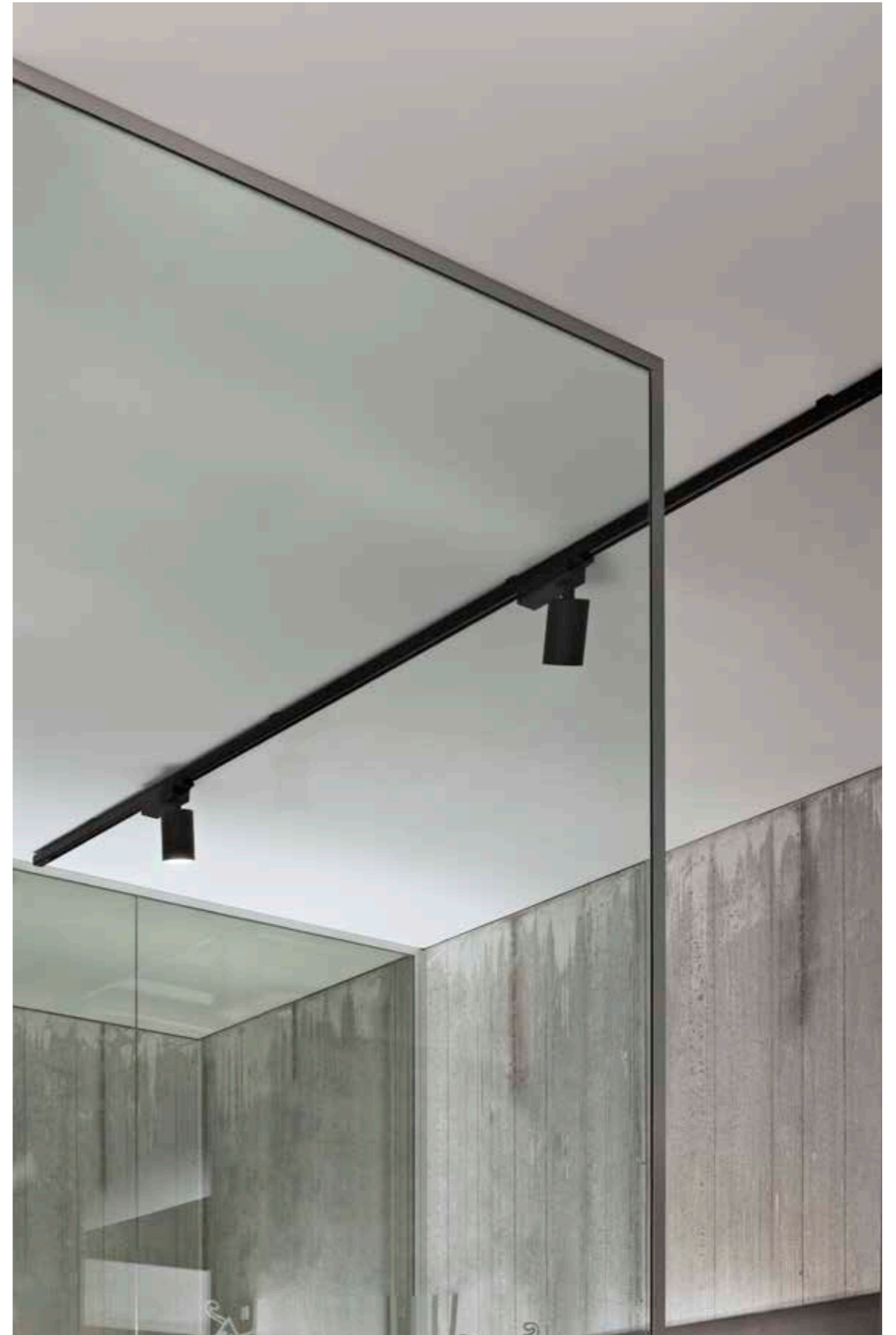

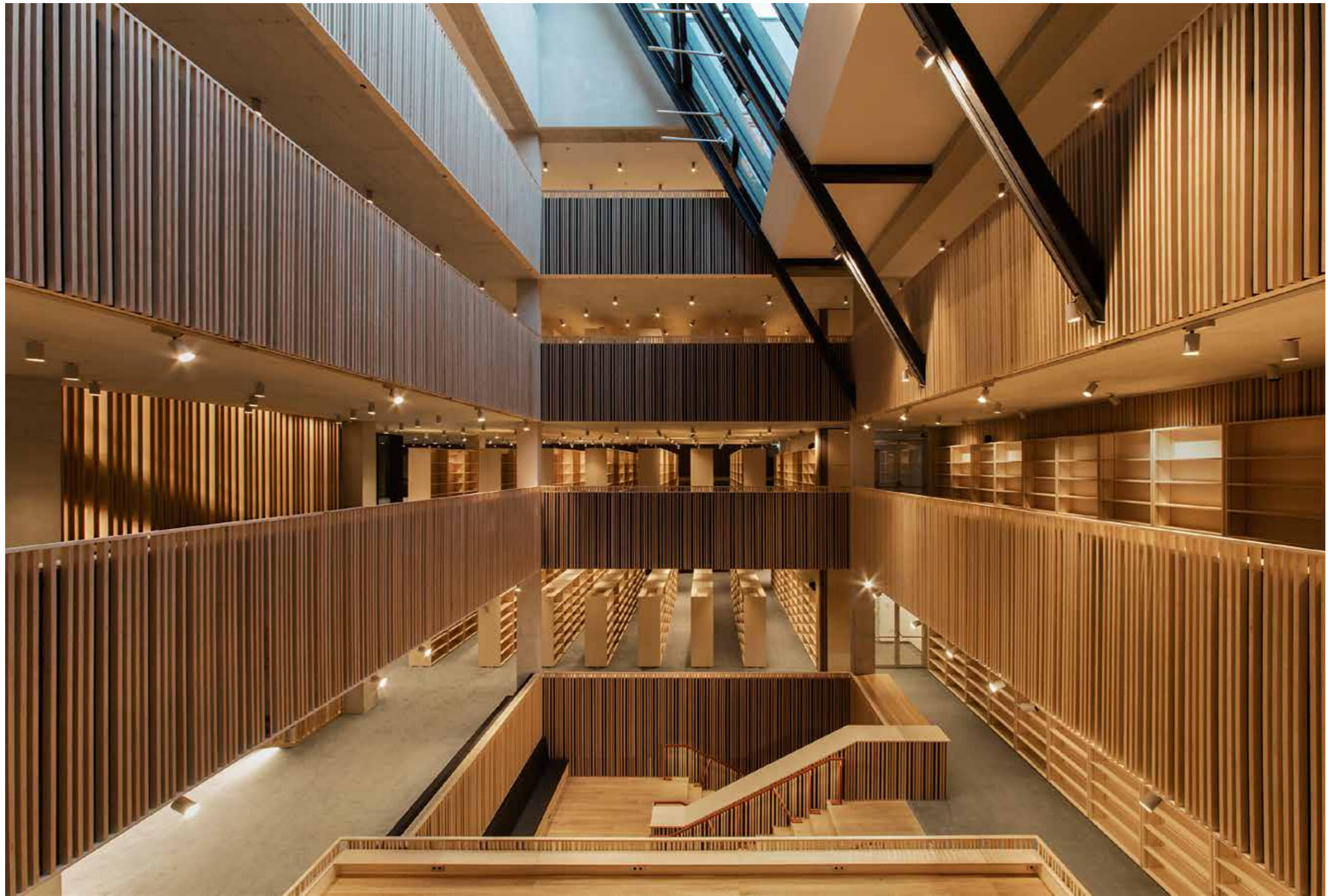





Einstellungssystem mit Zahnleiste, mit dessen Hilfe die Strahler in der Architektur verborgen werden können.

An adjustment system on a toothed guide permits concealing the spotlights, thus becoming integrated into the environment.



UT DOWNLIGHT

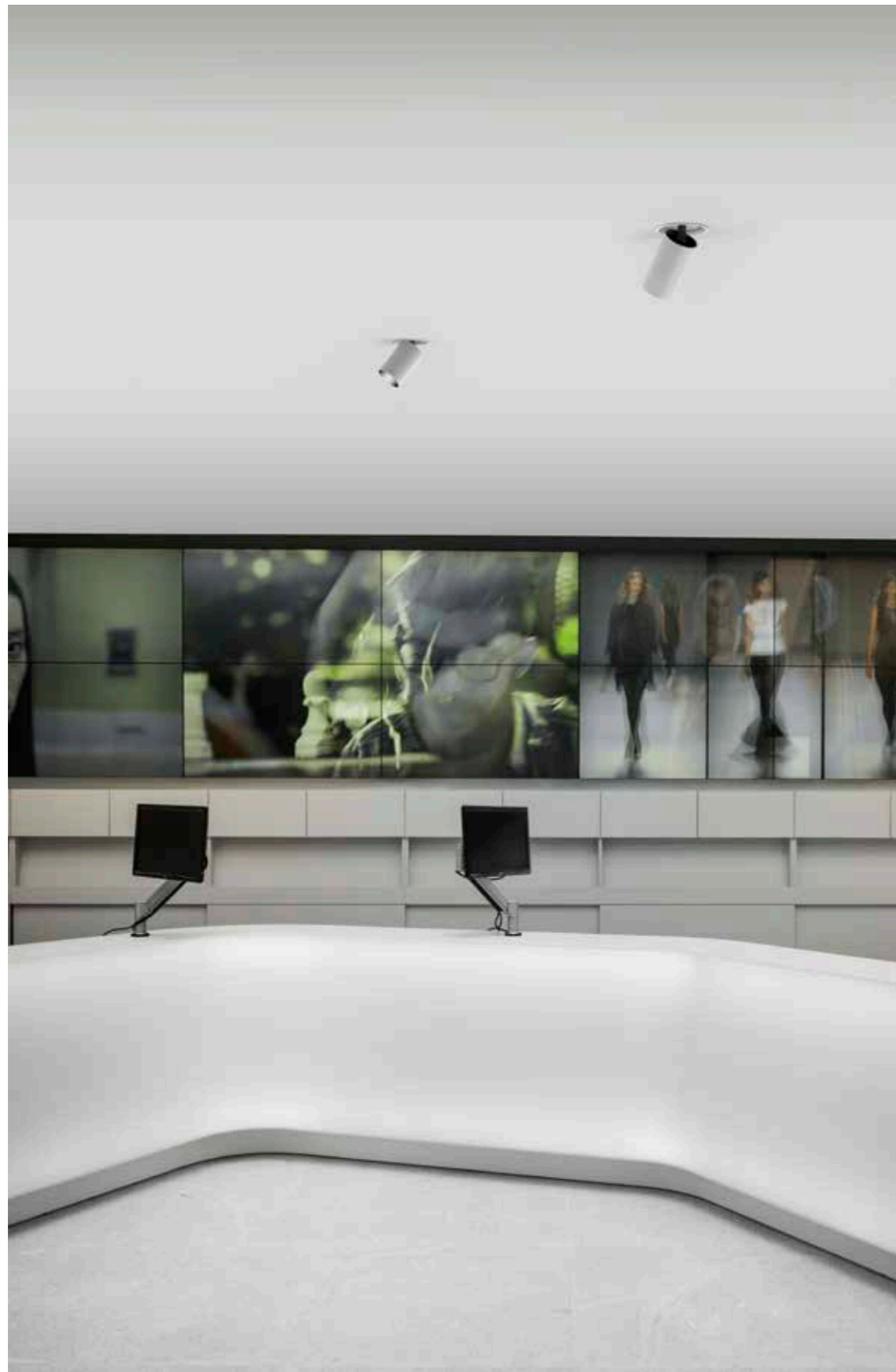

UT DOWNLIGHT

TRIM / NO TRIM
Ø 57



LED ARRAY
18W

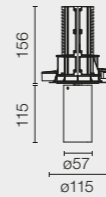
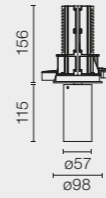

TRIM / NO TRIM
Ø 86



LED ARRAY
HIGH PERFORMANCES
27W

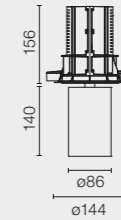
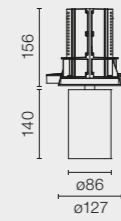

Spot



Medium



Flood

□ 30 Weiss
30 White



■ 14 Schwarz
14 Black



Drehbar um 360° und schwenkbar 90°.
Can be rotated 360° and swivelled 90°.

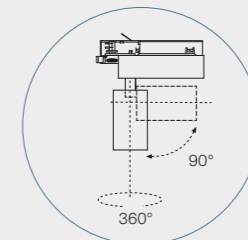

TRACK
Ø57



CEILING
Ø57



LED ARRAY
21,5W

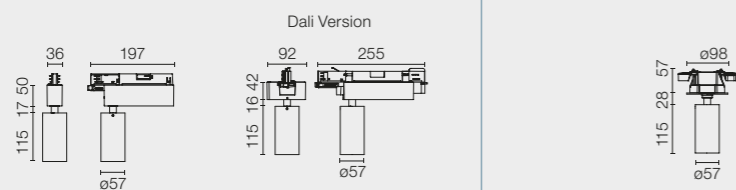

Super Spot Spot Medium Flood

□ 30 Weiss
30 White

■ 14 Schwarz
14 Black



Drehbar um 360° und schwenkbar 90°.
Can be rotated 360° and swivelled 90°.

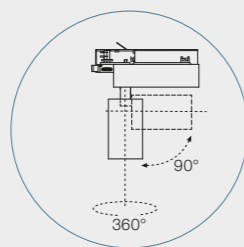

TRACK
Ø86



TRACK
WALL-WASHER
Ø86



TRACK
MULTICHIP
Ø86



PHOSPHOR LED
34,1W
29,3W

LED ARRAY
HIGH PERFORMANCES
32,8W

LED ARRAY
HIGH PERFORMANCES
32,8W

TOP LED
11,5W

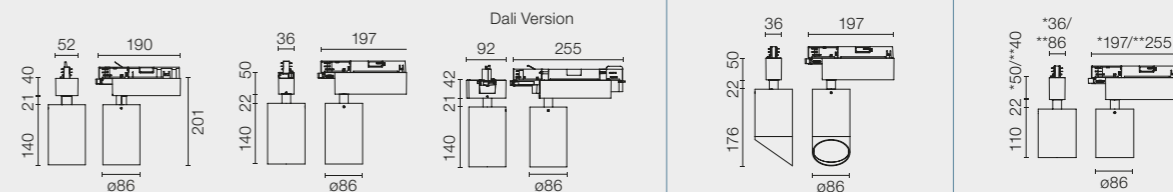

*Dimable/Non Dimable
**Dali Version

CEILING
Ø86



PHOSPHOR LED
34,1W
29,3W

LED ARRAY
HIGH PERFORMANCES
32,8W

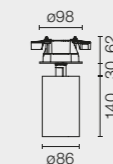

SOLID PURE

Programm von Innenraumstrahlern für die Akzentbeleuchtung mit leistungsstarken LED-Lichtquellen. Dank der großen Vielfalt von LED in Kombination mit der breiten Palette von Zubehör passt sich diese Produktfamilie allen Anwendungsformen an und ist insbesondere für hochprofessionelle Installationen und Gewerberäume geeignet. Die verschiedenen Öffnungsgrade des Lichtstrahls werden jedem lichttechnischen Anspruch gerecht. Erhältlich in Dali-Version sowie Möglichkeit von Schienen- und direkter Deckeninstallation. Das ausgeklügelte Befestigungssystem an der Schiene gewährleistet Präzision, Vielseitigkeit und problemlose Anwendung.

SOLID PURE

Indoor spotlight programme for accent lighting, available in high power LED technology light sources. The large variety of LEDs, combined with the availability of a wide range of accessories, enable this family of products to adapt to any type of application, and in particular, to commercial premises, as well as highly professional facilities. The different light beam angles satisfy any lumino-technical requirement. Available in Dali version and with possibility of direct ceiling or track mounting. The singular track fixture system guarantees precision, versatility and facilitates use.



DESIGNED BY KNUD HOLSCHER



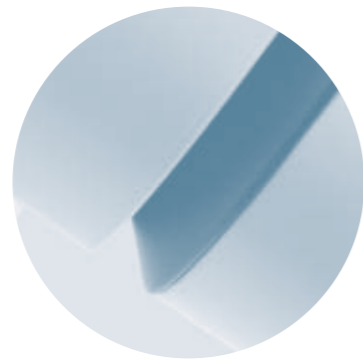

Aktives Kühlsystem zur Gewährleistung der Luftzirkulation (erhältlich für die 53W Version).

Active thermal cooling system to guarantee air flow recirculation (available for 53W version).









SOLID PURE TRACK



LED ARRAY
23W

LED ARRAY
30W

SOLID PURE CEILING



LED ARRAY
35W

LED ARRAY
53W

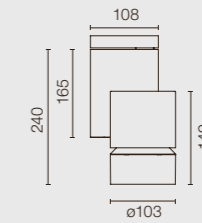
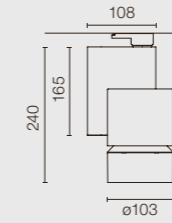

Spot



Medium



Flood

30 Weiss
30 White

14 Schwarz
14 Black



Drehbar um 360° und schwenkbar 190°.
Can be rotated 360° and swivelled 190°.

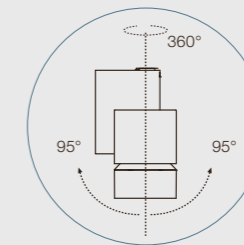

reddot design award
winner 2013



PURE

Familie von Strahlern für Akzentbeleuchtung im Innenbereich. Dank der vielfältigen Auswahl von Lichtquellen -einschließlich der neuartigen LED-Lösungen- in Kombination mit dem umfassenden Zubehörangebot ist diese Produktfamilie für jegliche Anwendung ideal geeignet, von Geschäftsräumen und Büros bis hin zu Wohngebäuden und hochprofessionellen Anwendungen in Museen. Die verschiedenen Lichtstrahlöffnungswinkel erlauben es, allen Beleuchtungsanforderungen gerecht zu werden. In Wand-, Schienen-, Decken- und Einbauausführung verfügbar. Mit besonderem Schienenbefestigungssystem, das einen genauen, vielfältigen und anwenderfreundlichen Einsatz gewährleistet.

PURE

Family of indoor spotlights for accent lighting. The great variety of possible light sources, even the latest generation of LED, combined with the availability of a wide range of accessories, makes this family of products particularly suitable for any type of application, from commercial premises and offices to typical residential environments or highly professional facilities such as museum exhibitions. With different beam angles, they enable us to meet the needs of any lighting requirement. Available in wall, track, ceiling and recessed mounting versions. The special fixture system on the track ensures precision, versatility and facilitates its use.



DESIGNED BY KNUD HOLSCHER





Der einziehbare Mechanismus des Dreiphasenadapters wird ohne Hilfe von besonderen Werkzeugen aktiviert. Das ist dank einem bedienungsfreundlichen Drucksystem möglich, der an der Seite des Hauptkörpers integriert ist. Wenn sich der Mechanismus in der Arbeitsposition befindet, bleibt der Adapter im Innenbereich des Hauptkörpers versteckt.

The retractable 3-phase adaptor can be actuated without using any special tool thanks to the easy-to-use push device integrated at the side of the main body. In its working position, the adaptor remains hidden inside the main body.

Wenn die Leuchte auf die Dreiphasenschiene installiert wird, bleibt der Adapter im Innenbereich des Hauptkörpers versteckt. Die Ausrichtung des Lichtstroms wird von dem Optikkörper direkt durchgeführt, während der Rest der Leuchte auf der Dreiphasenschiene fest verankert bleibt.

After the installation of the luminaire on the 3-phase track, the adaptor remains hidden inside the main body. The beam light adjustment is made directly on the optical body, while the rest of the luminaire is fixed and fastened on the 3-phase track.

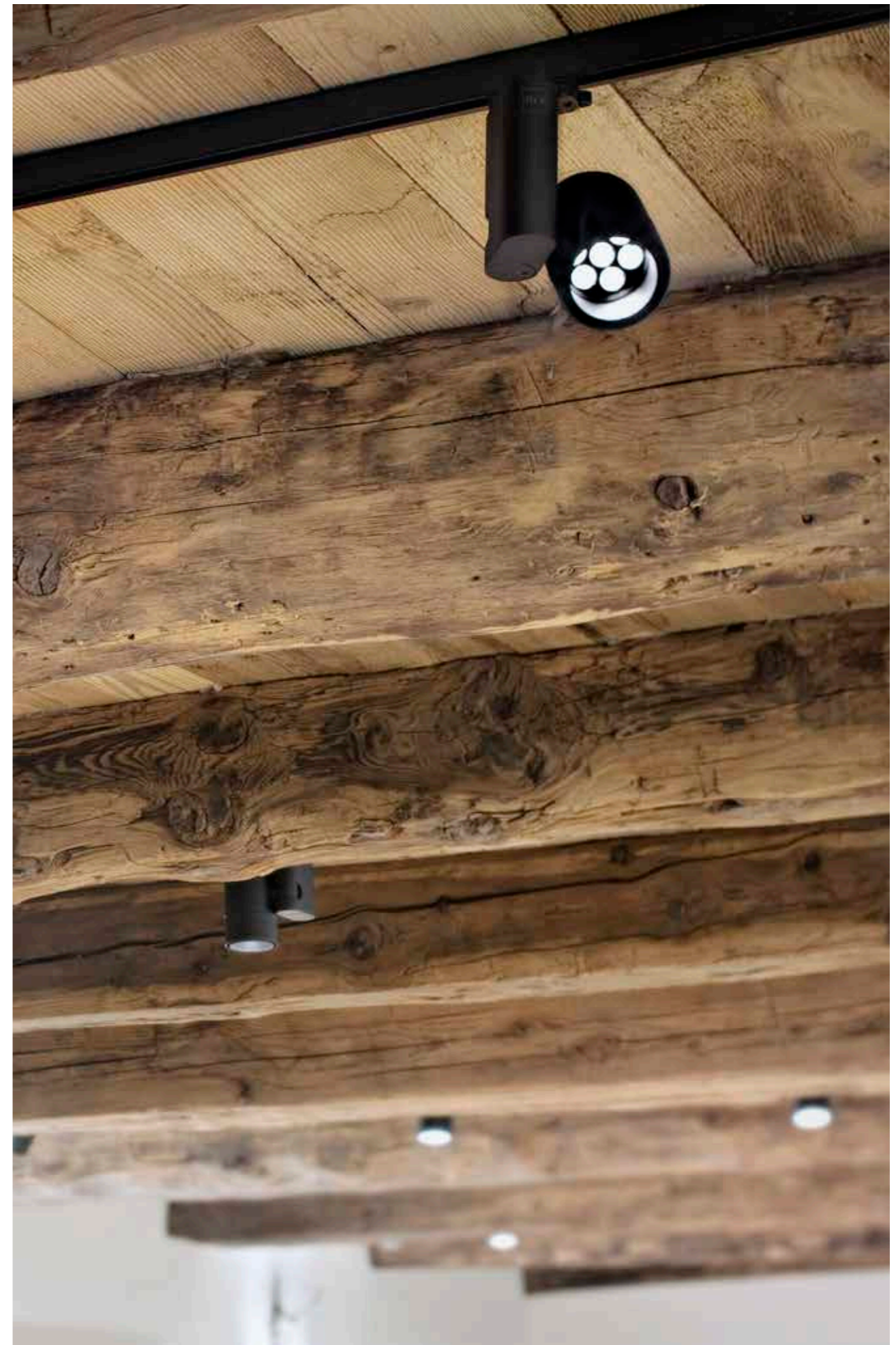



Der Strahler enthält einen Mechanismus, der die Schwenkung des Lichtstrahls blockiert, um einen eventuellen Strahlversatz bei der Wartung zu vermeiden.

The spot includes a mechanism that locks the light adjustment system in order to prevent it shifting during maintenance.



Alle Hallogenmodelle vom Pure Spot und vom Pure Spot Pro stützen sich auf Dimmer-Steuerung, und zwar von 10% bis zum 100% ihrer max. Leistungsfähigkeit. Dabei wird ein Leistungsmesser/Potentiometer angewandt, der im Gerät selbst eingebaut ist.

All halogen versions of Pure Spot and Pure Spot Pro are dimmable from 10% to 100% of full output using built-in potentiometer.



Die Anbauausführungen enthalten einen Mechanismus, der nach der Montage komplett versteckt bleibt. Einfache Montage ohne Hilfe von spezifischen Werkzeugen.

The surface installation version of the luminaire includes a mechanism which completely disappears from sight after being installed. Easy assembly without using any specific tool.

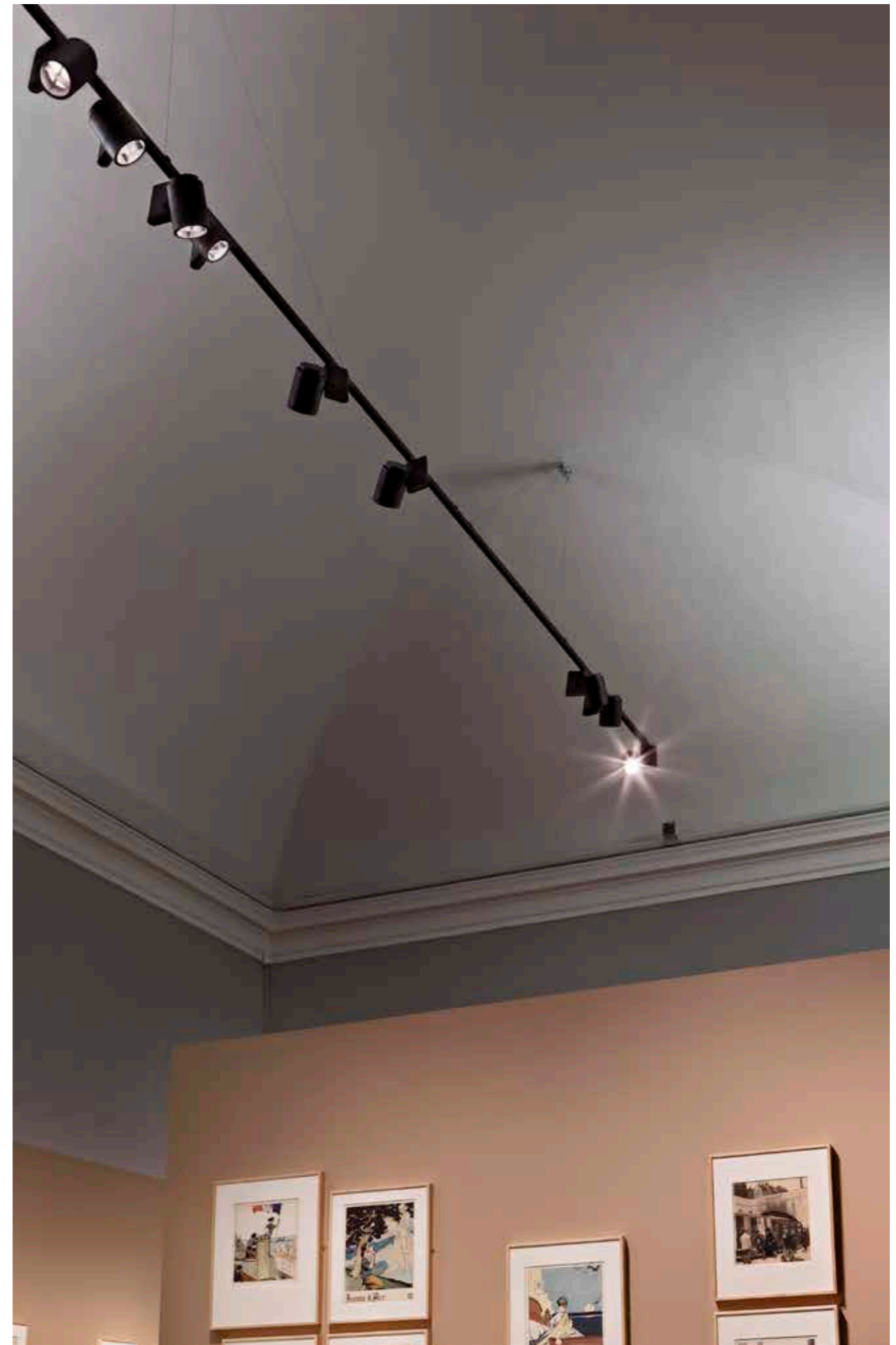

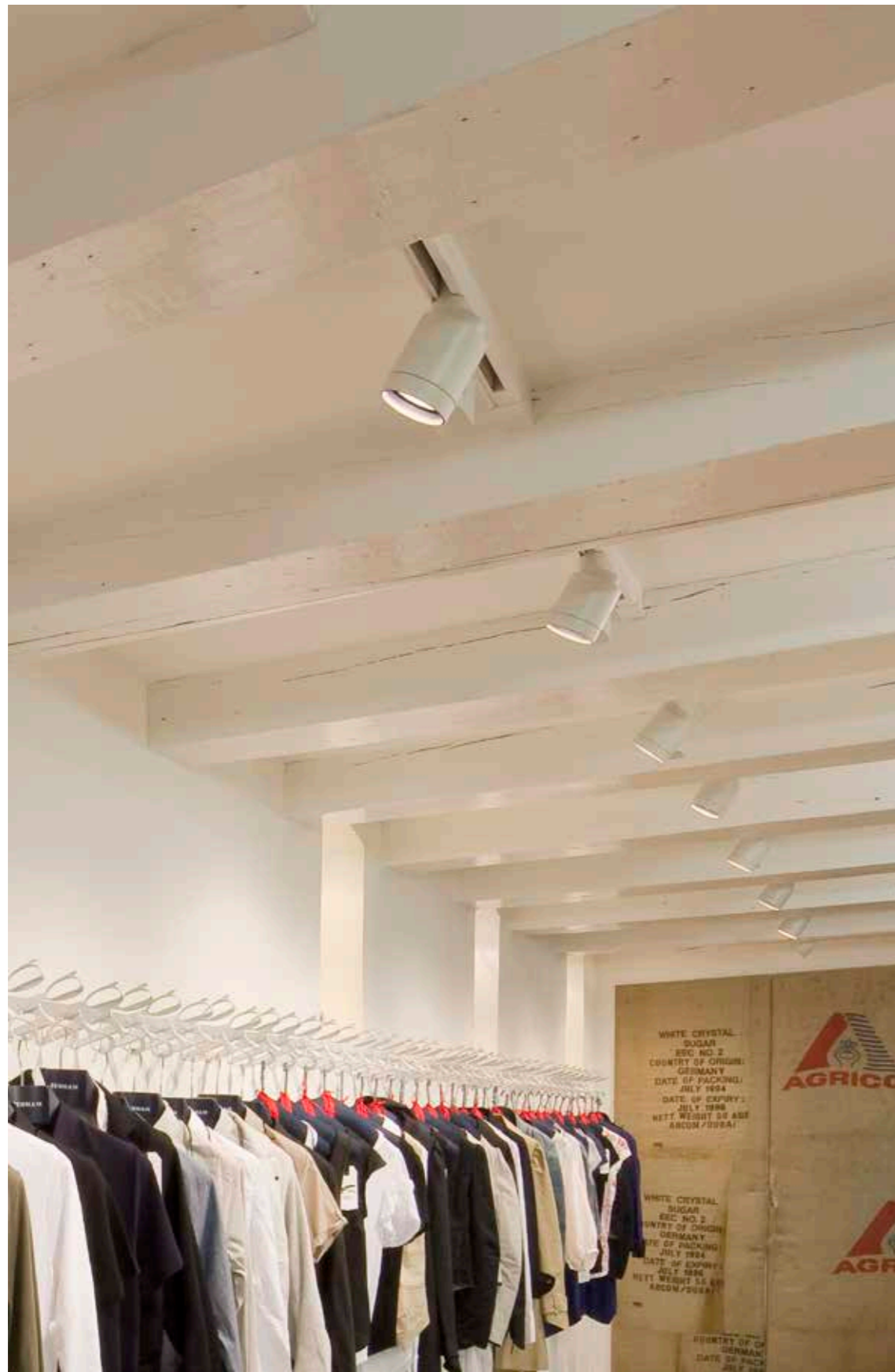

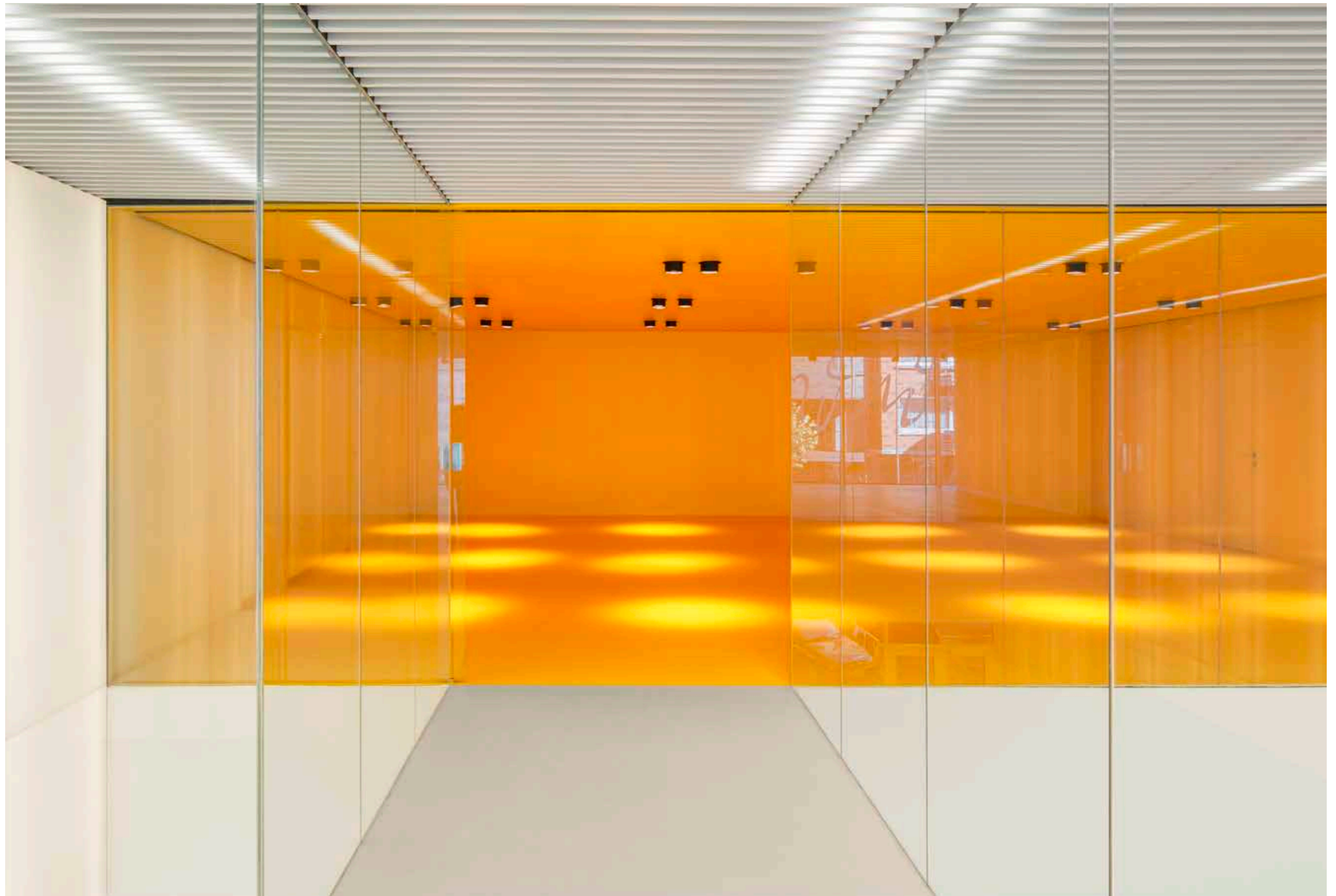

TRIM



Befestigungssystem für abgehängte Decken bis zu 30mm Dicke. Leichte, schnelle Montage ohne Spezialwerkzeug.

Luminaire fixing system for ceiling thicknesses of 0-30mm. Fast and easy luminaire installation. No special tools required.

NO TRIM



Leuchtenzubehör für einen perfekten Wandanbau - ohne Einbauring.

Accessory for a installation on the surface of the ceiling without using any rings for recessed installation.

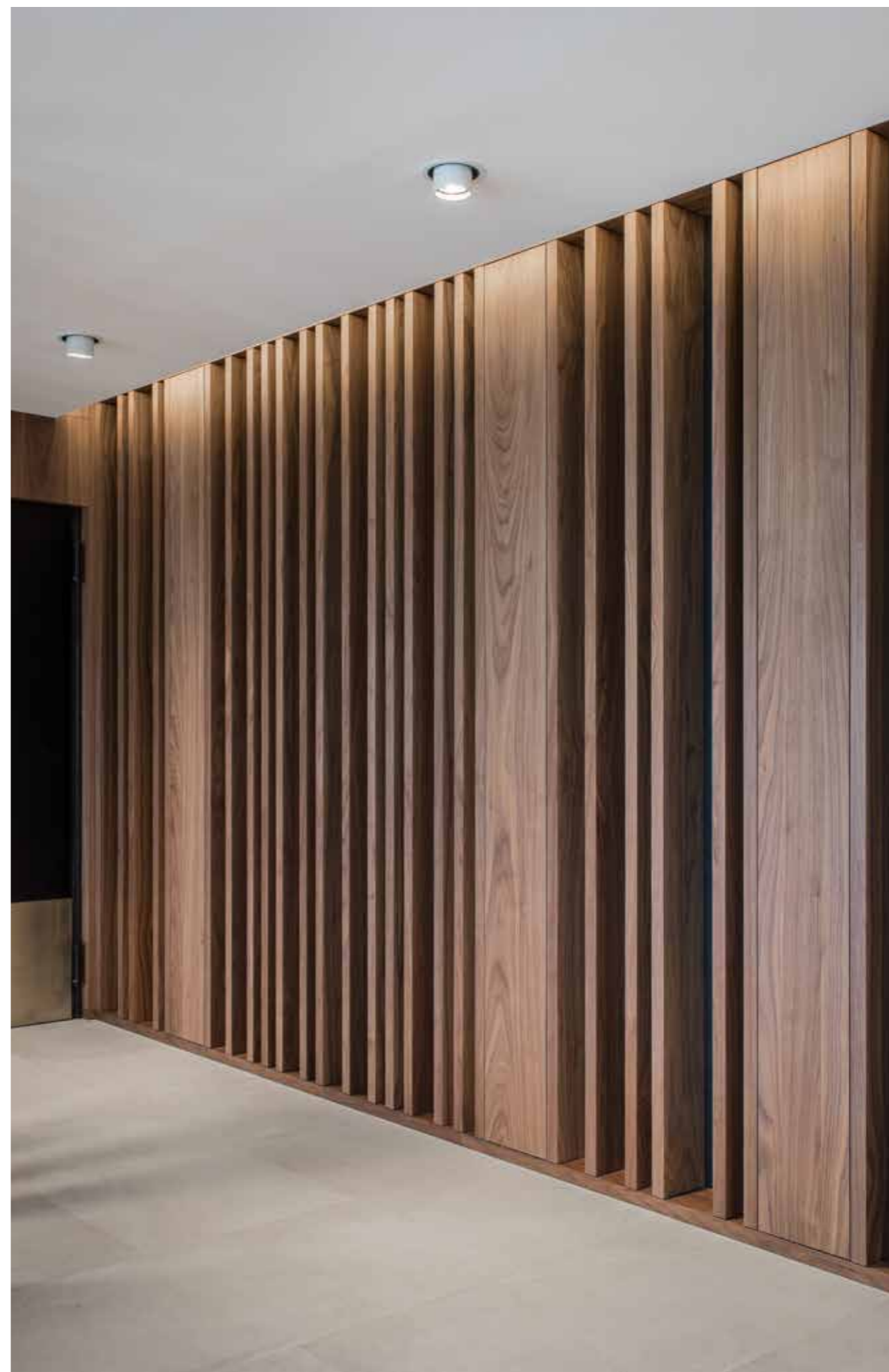

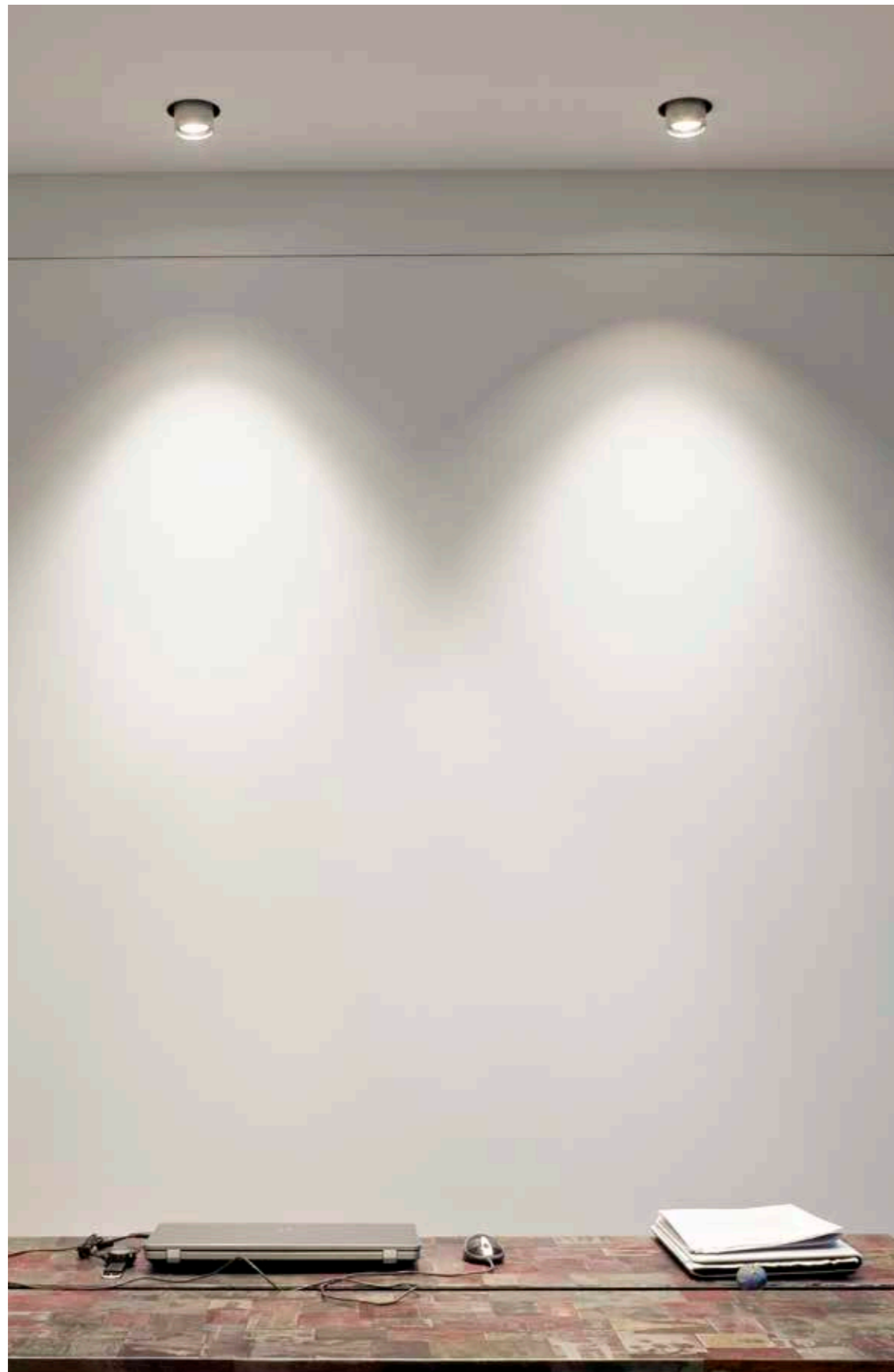



PURE SPOT

PURE SPOT

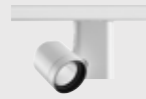

LED ARRAY
17,5W



PHOSPHOR LED
19,5W

PURE SPOT PRO



POWER LED
15,7W



QR-CBC 51
max 50W
- OR -
LED QR-CBC 51
7/10W

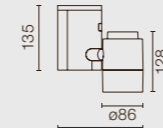
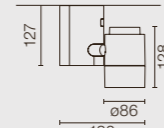
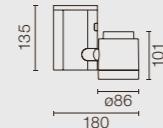
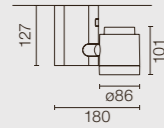

Spot



Medium



Flood



Wide Flood

30 Weiss
30 White

02 Grau
02 Grey

14 Schwarz
14 Black

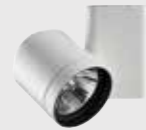

Drehbar um 180° und schwenkbar 180°.
Can be rotated 180° and swivelled 180°.

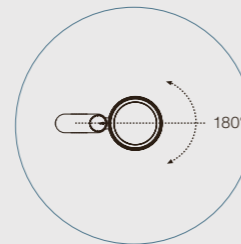
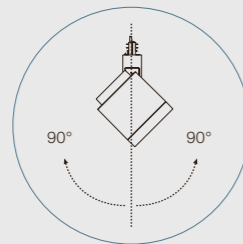

reddot design award
winner 2008

DESIGN PLUS

382

PURE DOWNLIGHT

PURE DOWNLIGHT TRIM / NO TRIM



PHOSPHOR LED
13,6W



POWER LED
15,7W

QR-CBC 51
max 50W
- OR -
LED QR-CBC 51
7/10W

TRIM

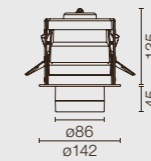

NO TRIM

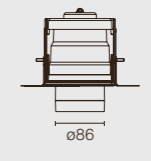

Spot



Flood



Wide Flood

30 Weiss
30 White

02 Grau
02 Grey

14 Schwarz
14 Black

Pure Downlight
Trim



Pure Downlight
No Trim



Drehbar um 360° und schwenkbar 60°.
Can be rotated 360° and swivelled 60°.

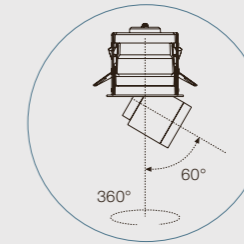

383

Modulares Schienensystem für Niederspannungsbeleuchtung zur Wand-, Decken- und Hängemontage. Für die unterschiedlichsten Anwendungen im Geschäfts-, Wohn- und Ausstellungsbereich geeignet. Anwenderfreundliches Verbindungssystem zum schnellen Anschluss an das Stromnetz. Die Leuchten können auf der Schiene beliebig positioniert und montiert sowie ohne Werkzeugeinsatz versetzt oder entfernt werden.

LIGHTLIGHT®

Modular track system with very low voltage and with especially compact dimensions suitable for wall, ceiling and suspension mounting. Different applications make it suitable for lighting in different areas: work, residential, exhibitions. A simple system allows for fast connection to the power supply. The devices can be mounted in any position on the track and they can be moved or removed without having to use special tools.







Halogenlampen und Diffusor mit sandgestrahltem Sicherheitsglas garantieren eine gleichmäßige Verteilung des Lichtes insbesondere zur Beleuchtung aus kurzem Abstand.

Halogen lamps and diffuser with sand-blasted safety glass ensure an even light distribution, especially for short distance lighting.

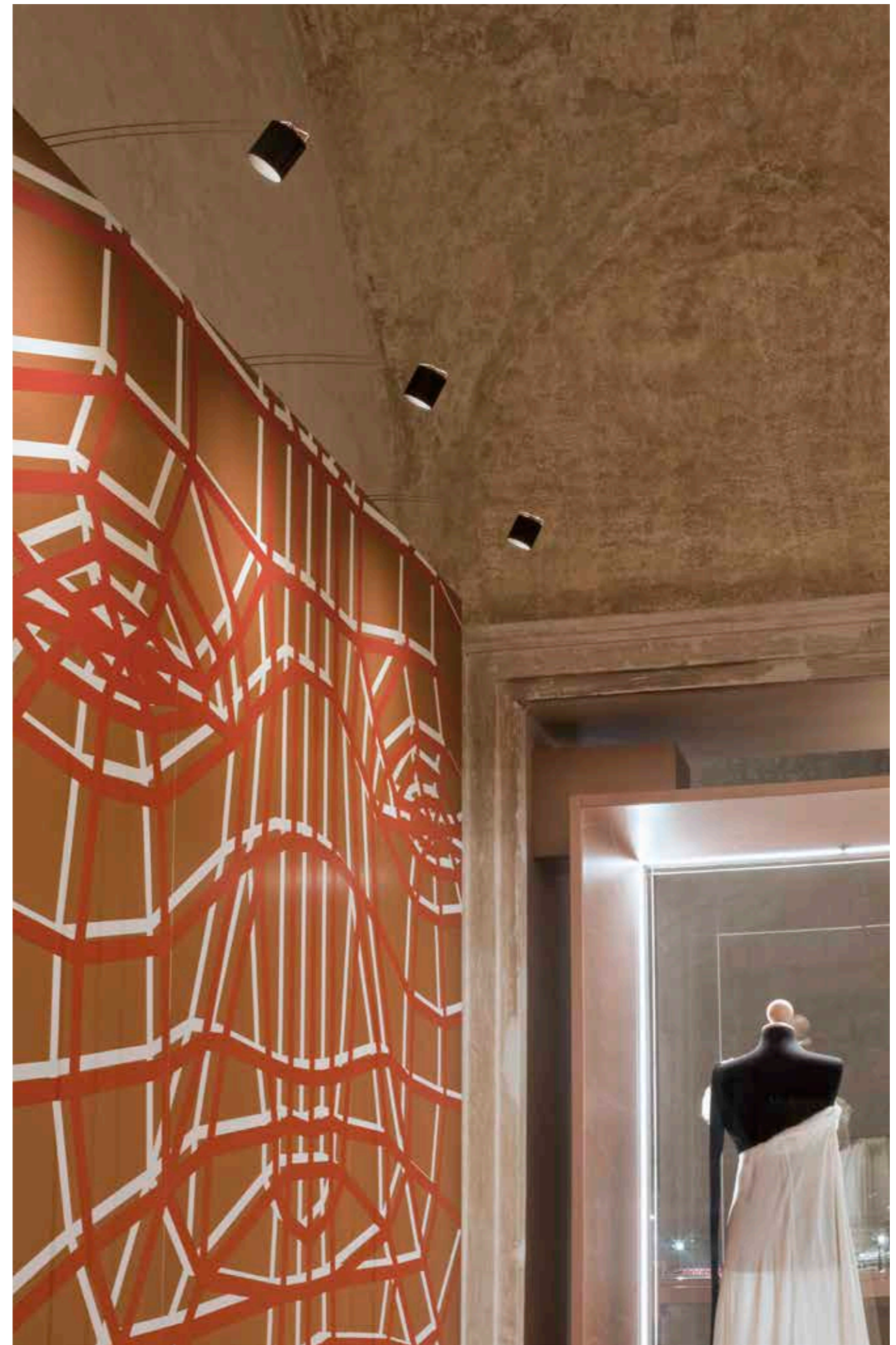

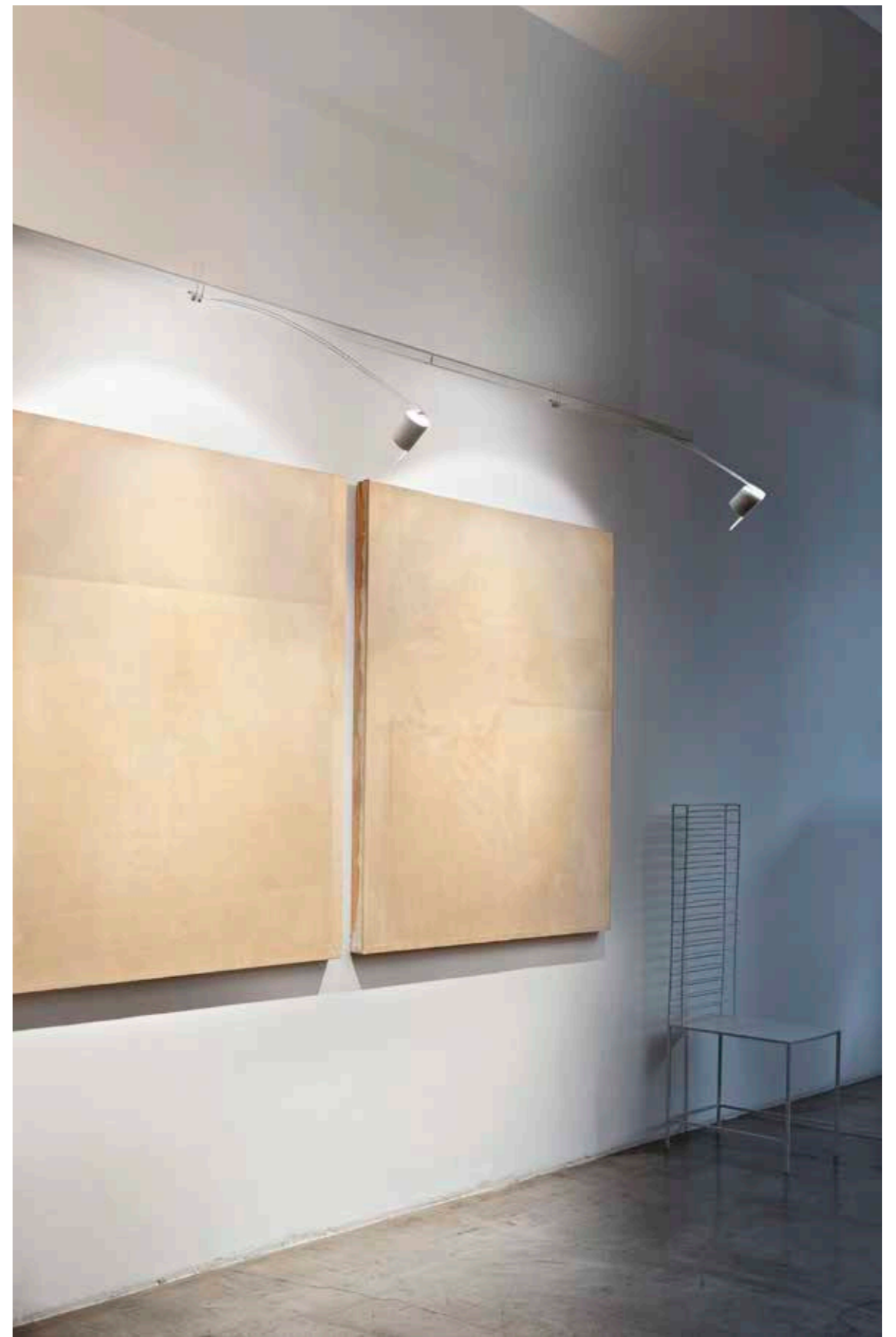



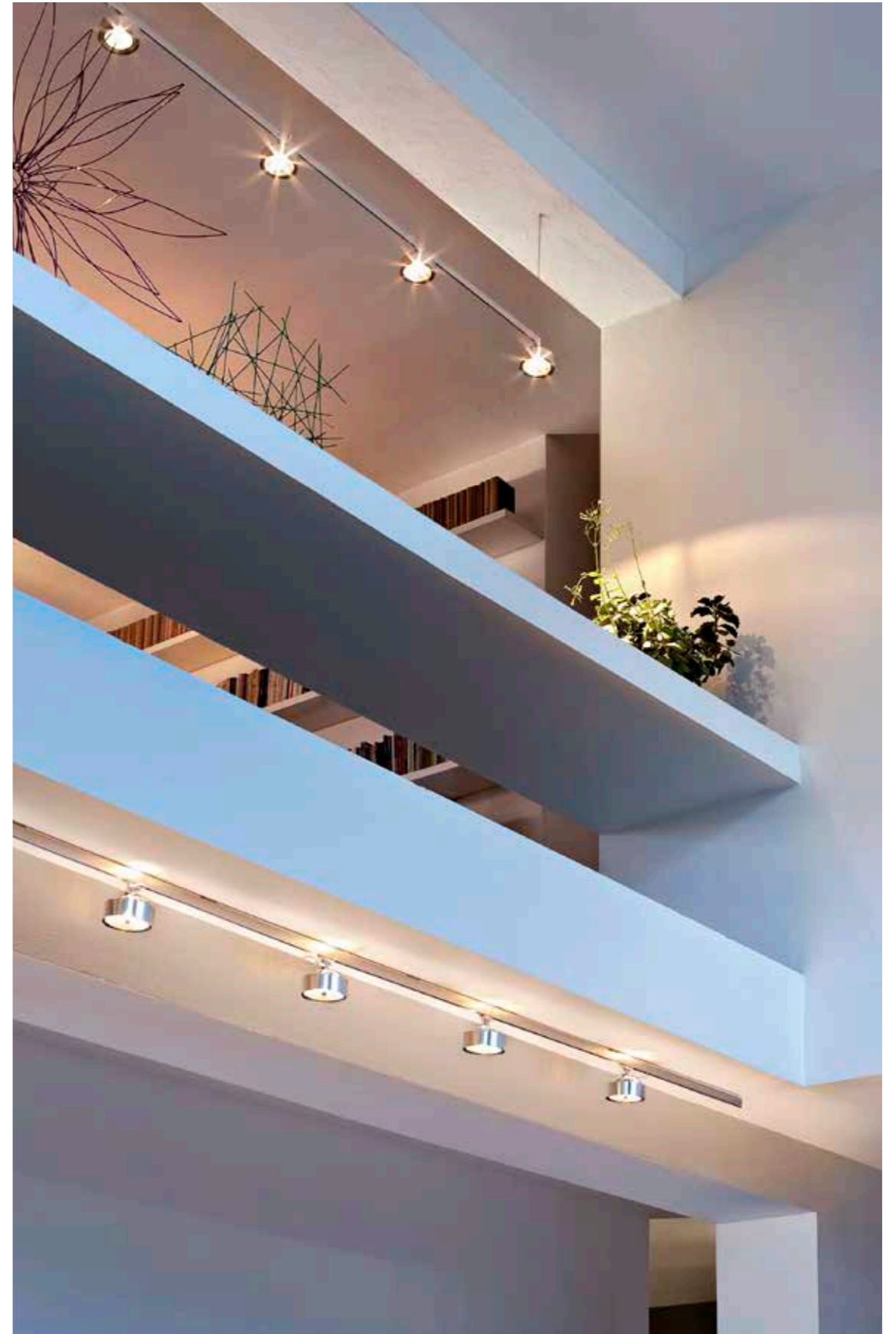

LIGHTLIGHT® WALL

TUBE



QR-CBC 51
20/35/50W
- OR -
LED QR-CBC 51
4/7/10W

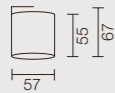

POINT

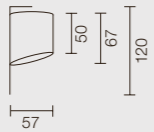

DISC 111



QR-111
20/50/60W
- OR -
LED QR-111

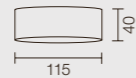

B15



QR-C 38
20/35W
- OR -
LED QR-C 38
6W

POSTER

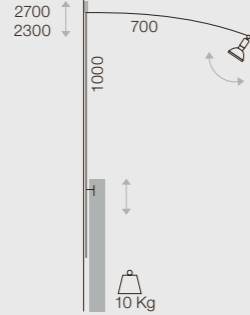

SHOP

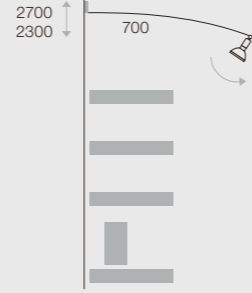

SHOP-W

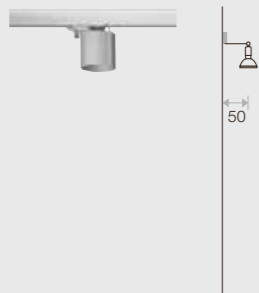

ANGLE

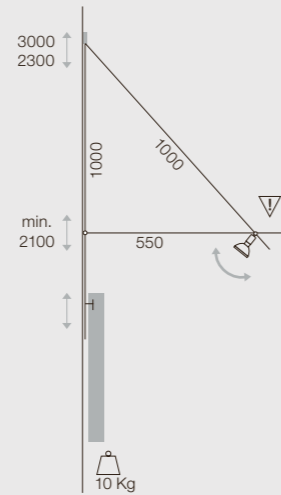
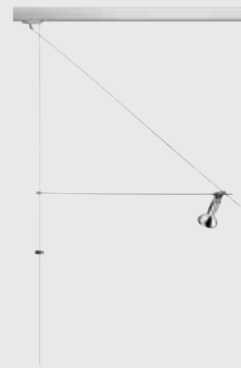

MAX-W

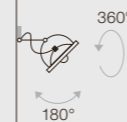

TUBE



QR-CBC 51
20/35/50W
- OR -
LED QR-CBC 51
4/7/10W

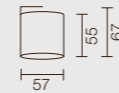

POINT

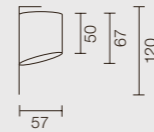

DISC 111



QR-111
20/50/60W
- OR -
LED QR-111

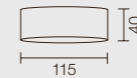

PINPIN



QR-CBC 51
20/35W
- OR -
LED QR-CBC 51
4W

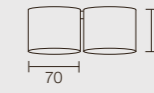

B15



QR-C 38
20/35W
- OR -
LED QR-C 38
6W

FLEX



MAX

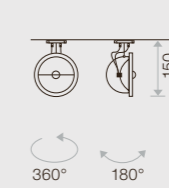

PINPIN

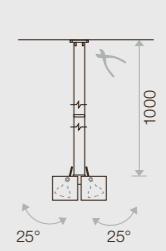

SHOP-V 100

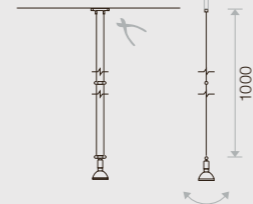

SPOT 5



LIGHTLIGHT® WALL - PEND / CEILING - MONO

□ W Weiss
W White

■ A Eloxiertes Aluminium
A Anodized Aluminium

■ B Schwarz Eloxiert
B Anodized Black

■ P Hochglänzendes Aluminium
P Polished Aluminium



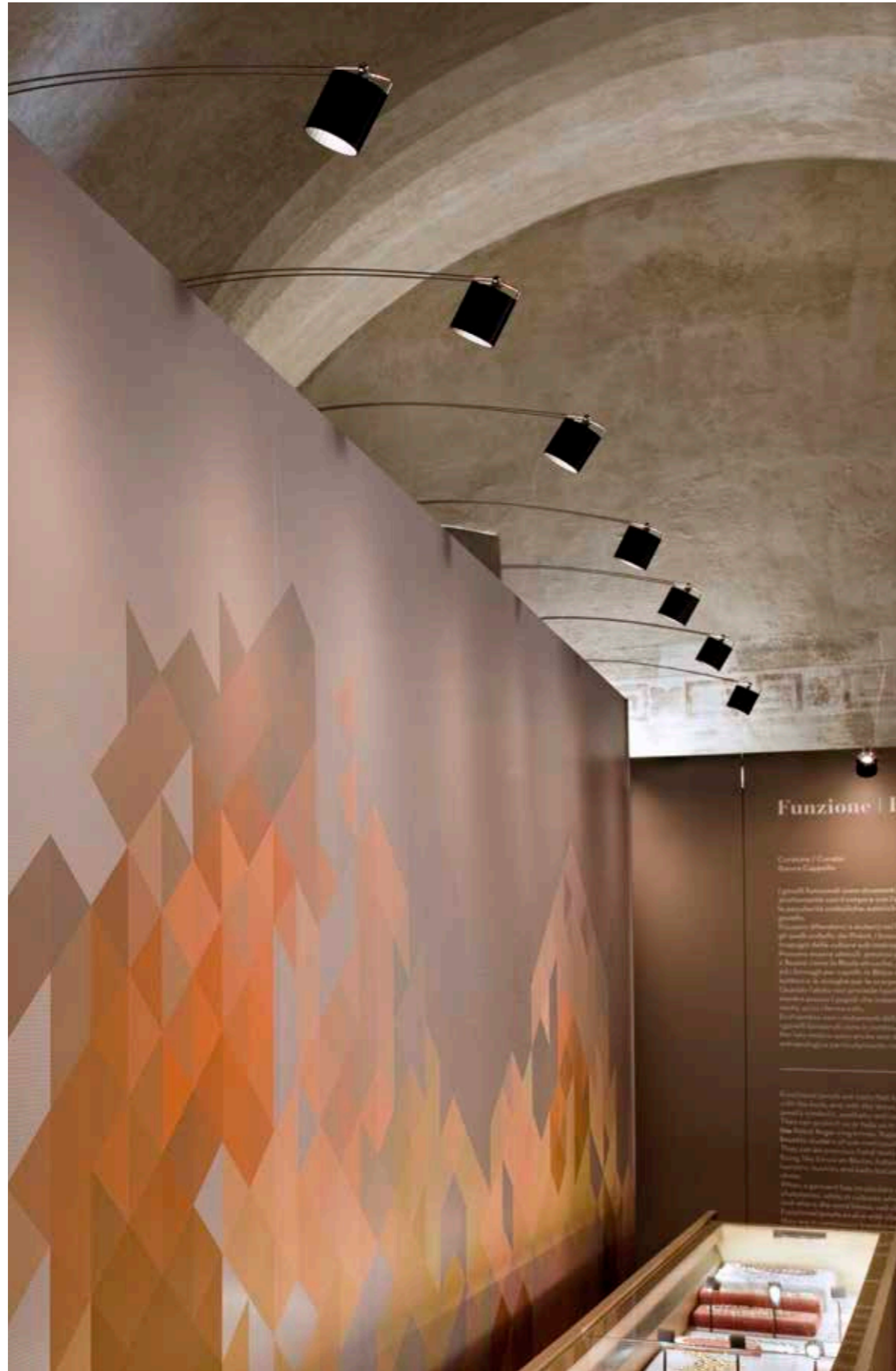

TUBE



QR-CBC 51
20/35/50W
- OR -
LED QR-CBC 51
4/7/10W

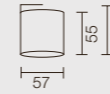

POINT



QR-111
20/50/60W
- OR -
LED QR-111

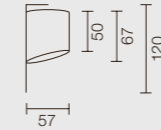

DISC 111



QR-111
20/50/60W
- OR -
LED QR-111



PINPIN



QR-CBC 51
20/35W
- OR -
LED QR-CBC 51
4W

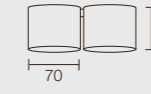

B15



QR-C 38
20/35W
- OR -
LED QR-C 38
6W

SHOP MONO RECESSED / SURFACE

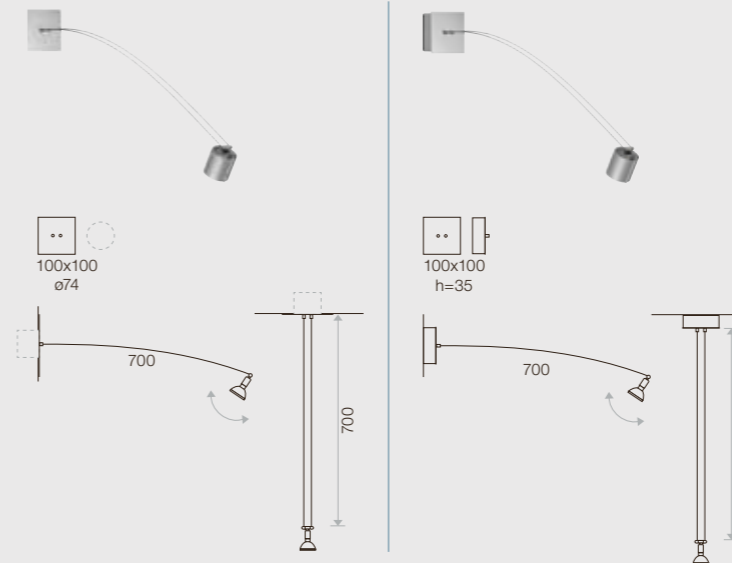

PINPIN MONO RECESSED / SURFACE



MAX MONO RECESSED / SURFACE

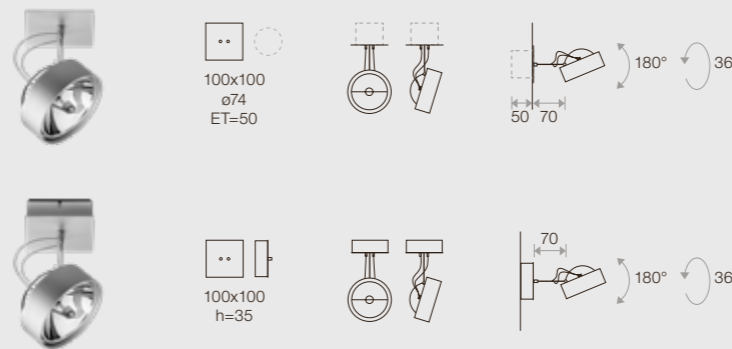

BON JOUR

LED-Einbauleuchten mit einzigartigem Design, bei dem nur eine kleine Erhebung die Präsenz der Lichtquelle andeutet. Erhältlich in drei Größen mit unterschiedlicher Optik für die optimale Personalisierung. Die klar gezeichneten Linien werden je nach Modellversion von einem hochwertigen neutralen oder metallischen Finish akzentuiert.

BON JOUR

Recessed LED with an unusual design, thanks to the small edge that defines the presence of the luminaire. Comes in three sizes with different optics for a better personalisation. Pure lines highlighted with the refined finishes, in neutral and metal plated versions.



DESIGNED BY PHILIPPE STARCK





404



405

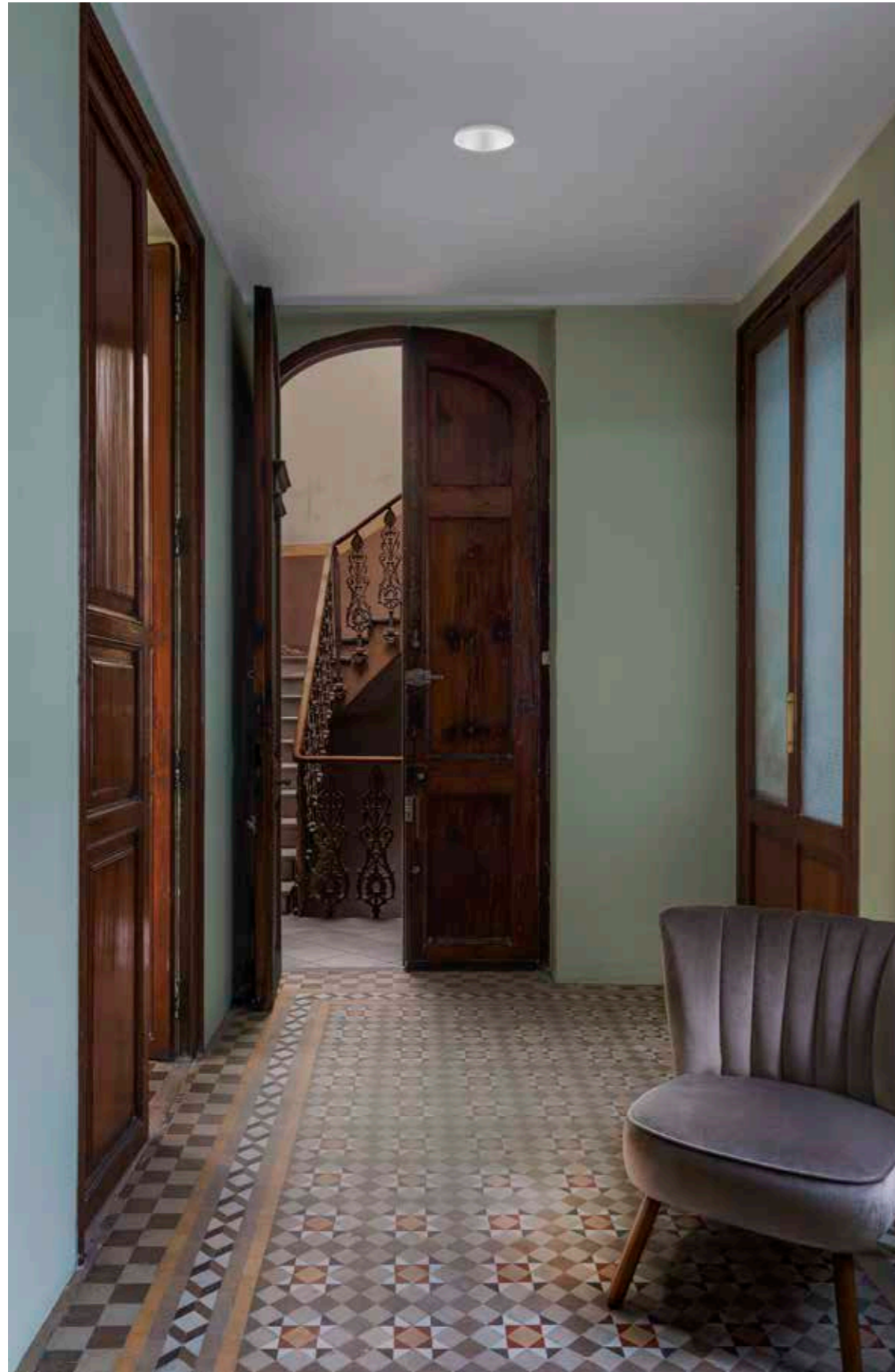



BON JOUR
Ø45



POWER LED
6W

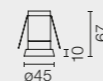

BON JOUR
Ø90



LED ARRAY
13,5W

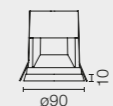

BON JOUR
Ø145



LED ARRAY
27W

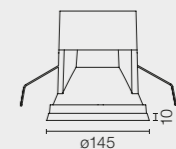

□ 01 Weiss
01 White



■ CU Kupfer
CU Copper



■ 14 Schwarz
14 Black



FREE SIXTY

Einbaustrahler von minimalistischer Ästhetik. In diversen Ausführungen erhältlich. Perfekt geeignet für Geschäfte oder Restaurants. Elegantes und edles Design mit revolutionärem kardanischem Ausrichtsystem, das der Lampe eine Beweglichkeit von 360° verleiht. Eine einfache Berührung mit der Hand oder einem Besenstiel reicht aus, um die Leuchte neu auszurichten. Eine Leuchte von strategischem Design, entworfen von Philippe Starck, die die Komplexität einer abgerundeten Infrastruktur mit bewundernswerter Kasuistik und Genialität verbindet.

FREE SIXTY

Recessed, aesthetically minimalist projector with various finishes, perfect for businesses and restaurants. Fine and elegant design but with a revolutionary floating swivel, which gives the device full mobility of 360°, operated with a simple touch of the hand or a broom, for instance. Created by Philippe Starck, this strategically-designed device involves a complex infrastructure seasoned with the most admirable casuistry and creativity.



DESIGNED BY PHILIPPE STARCK







Kardanische Dichtung, die dem System eine innovative Orientierung verleiht.

Universal joint giving the system an innovative angle.



Honeycom für maximalen Sichtkomfort integriert.

Integrated honeycomb grid for maximum visual comfort.



Leichtes Orientierungssystem 360° von unten mit einer bloßen Berührung.

Easy 360° rotation system from the bottom, with one simple touch.



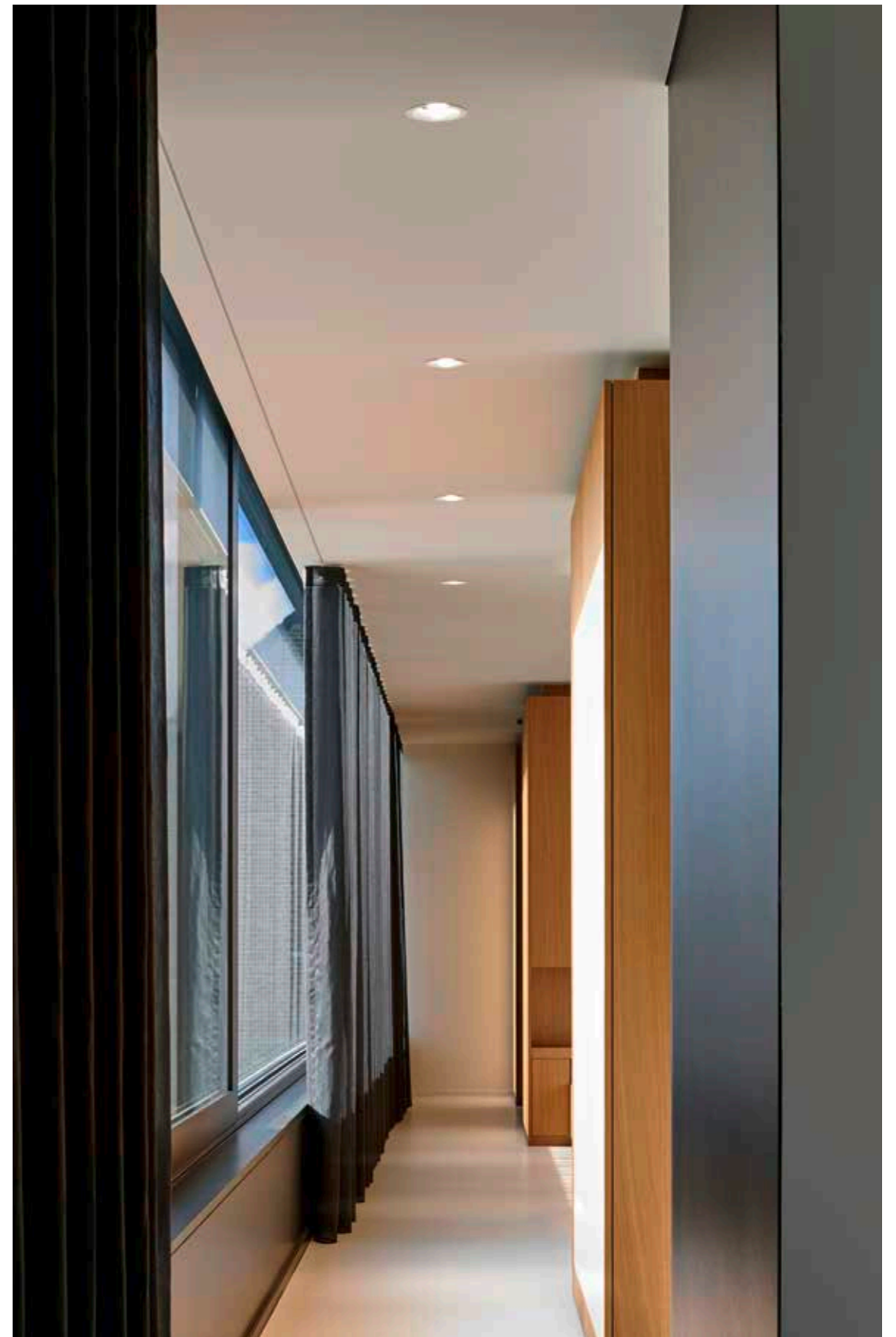

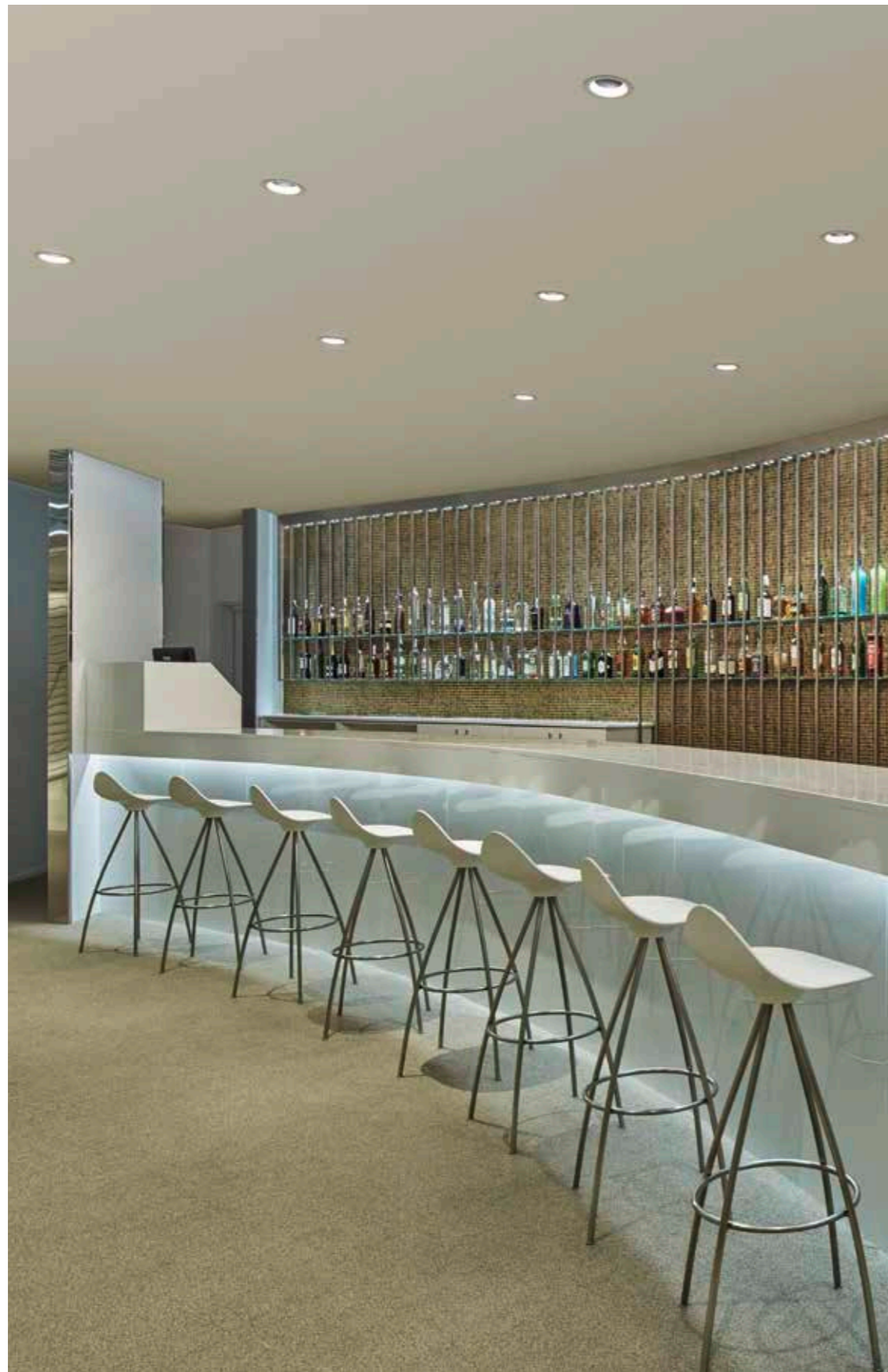

TRIM

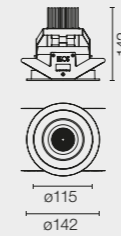

NO TRIM

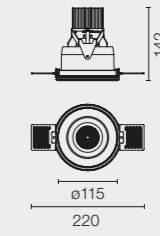

LED ARRAY
16W

□ 30 Weiss
30 White

■ CU Kupfer
CU Copper

■ 14 Schwarz
14 Black

Free Sixty
Trim



Free Sixty
No Trim



Einbaustrahler-Kollektion für die Installation in Innenräumen mit LEDs der neuesten Generation und Leuchten mit herkömmlichen Lichtquellen. Die breite Auswahl an Größen und Designs ermöglicht die perfekte Integration in allen Umgebungen. Das Design des optischen Gehäuses gewährleistet einen hohen visuellen Komfort. Enthält auch Modelle für die rahmenlose Schnellinstallation mit dem Fast&Perfect Installationssystem.

KAP

A collection of recessed elements for interior installations that include avant-garde LED solutions and luminaires with a traditional light source. A wide variety of sizes and finishes that ensure a perfect integration in all environments. Optic body to ensure an excellent visual comfort. Includes different versions for a fast frame-free installation with the Fast&Perfect system.



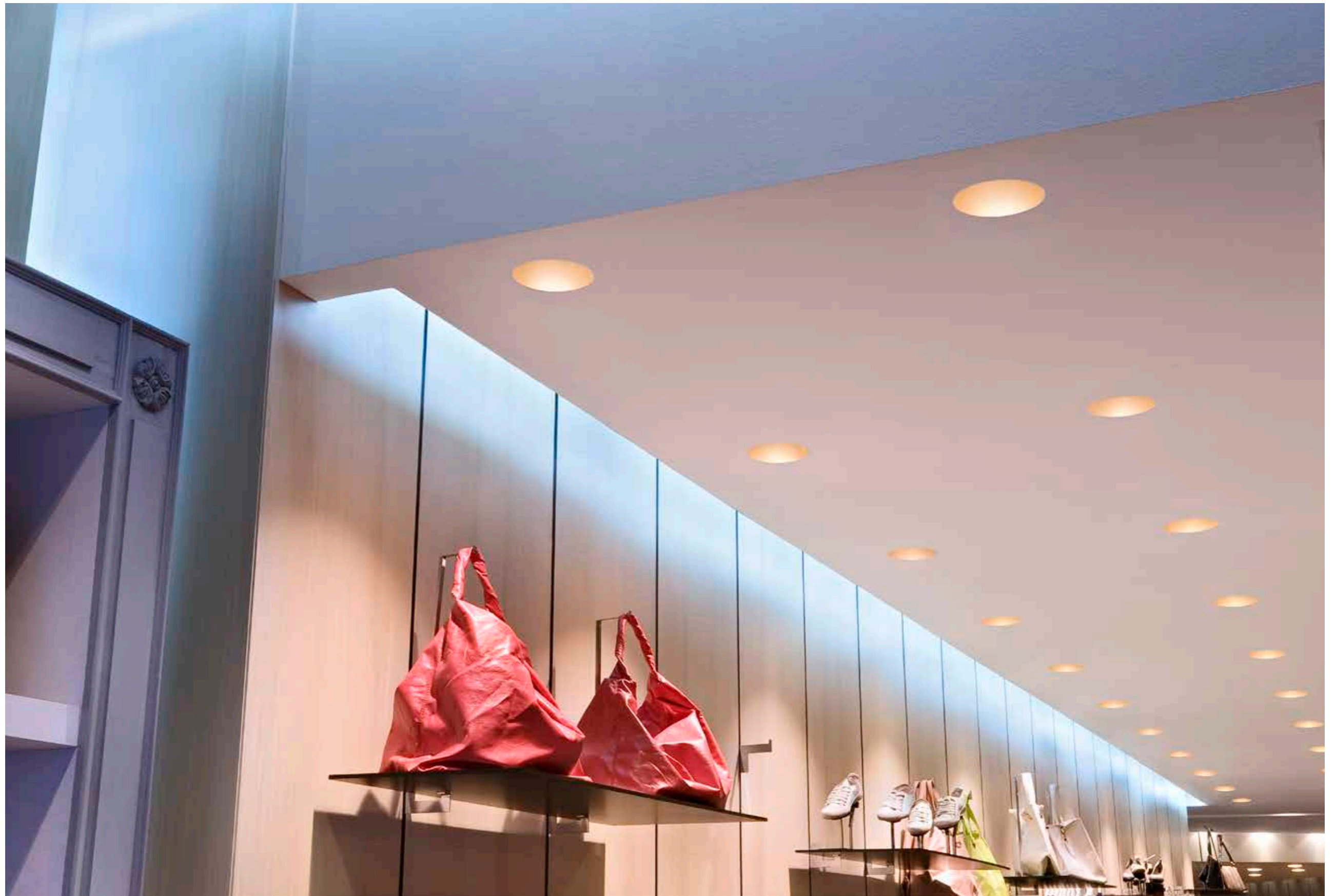



Die Leuchte enthält in ihrem Hauptkörper ein Kühlerelement zur Temperaturkontrolle.

The main body of the luminaire contains a radiator for temperature control.

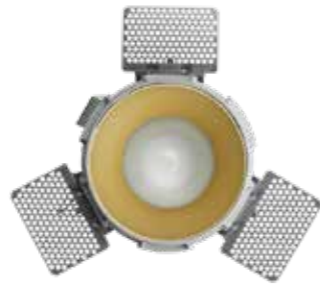

Die Schalung enthält einen Diffusor aus Thermoplastkunststoff zur gleichmäßiger Verteilung des Lichtes auf horizontalen Arbeitsflächen.

The remote housing includes a thermoplastic diffuser which ensures a perfect light distribution on horizontal surfaces.



Bei den Modellen vom Typ KAP 80 sowie optional bei den Typen KAP 105 und Square erfolgt die Installation des Trim Installationsrahmens mithilfe des exklusiven Fast&Perfect Schnellinstallations-systems von FLOS.

In the KAP 80 and, as an option in the KAP 105 and Square, the trim installation frame is installed with the exclusive FLOS Fast&Perfect system.



Deckendose für die Installation an Zementdecken erhältlich.

Available with for the installation in cement ceilings.

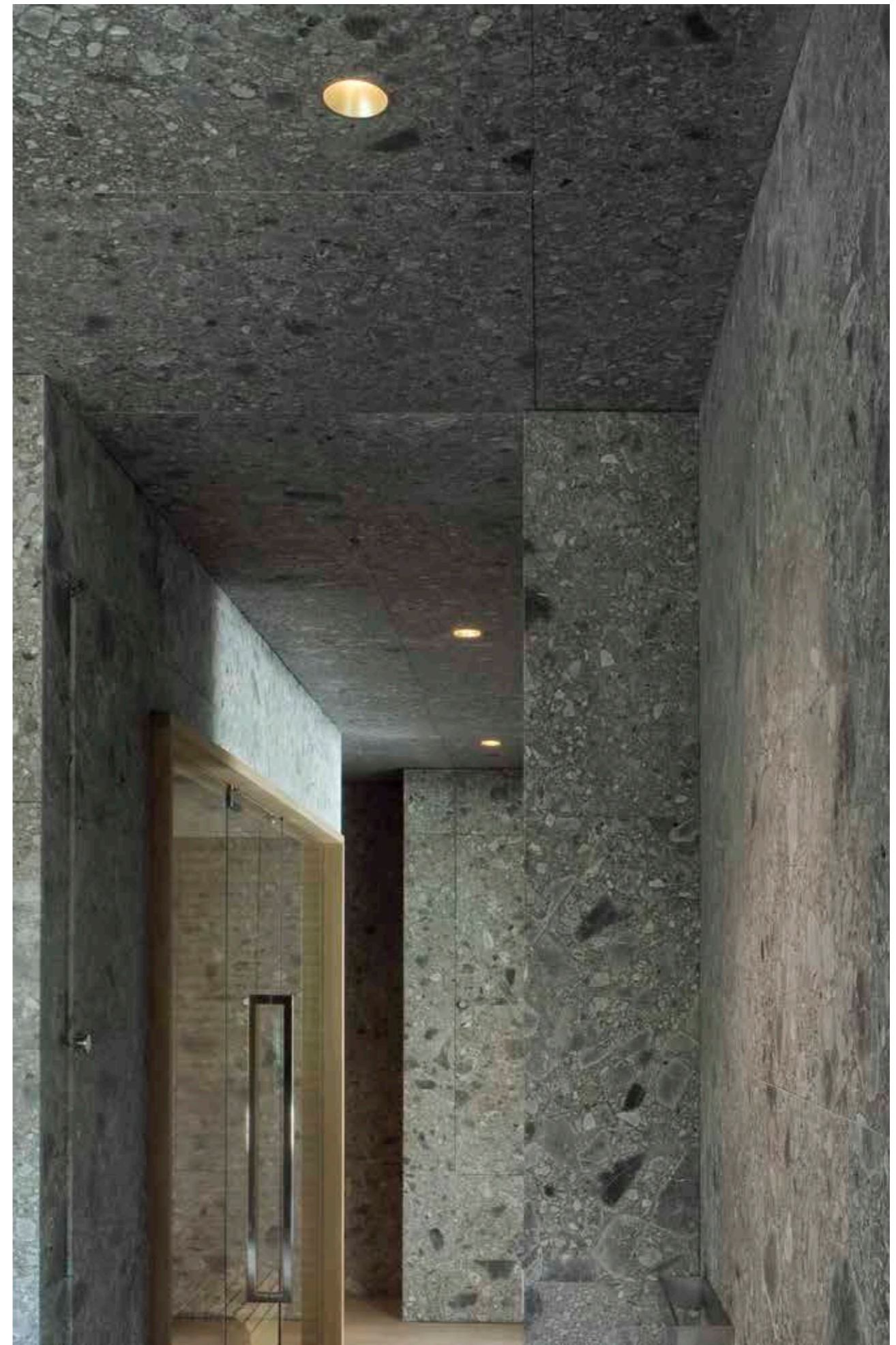







Alle Modelle vom Typ Easy Kap 80 LED werden mit Opal-Diffusor geliefert, der montiert werden kann, um den visuellen Komfort zu erhöhen und die Abschirmung der Lichtquelle zu vergrößern.

All the Easy Kap 80 LED have an opaline diffuser that can be assembled to increase visual comfort and screening of the luminaire.

Totaleffekt, rahmenlos, dank eines neuen Einbausystem. Die Bajonettmontage ermöglicht den Lampenaustausch ohne Hilfe von Werkzeugen.

Total No Trim effect achieved due to a new installation system. The bayonet-based assembly allows to replace the lamp without using any particular tools.



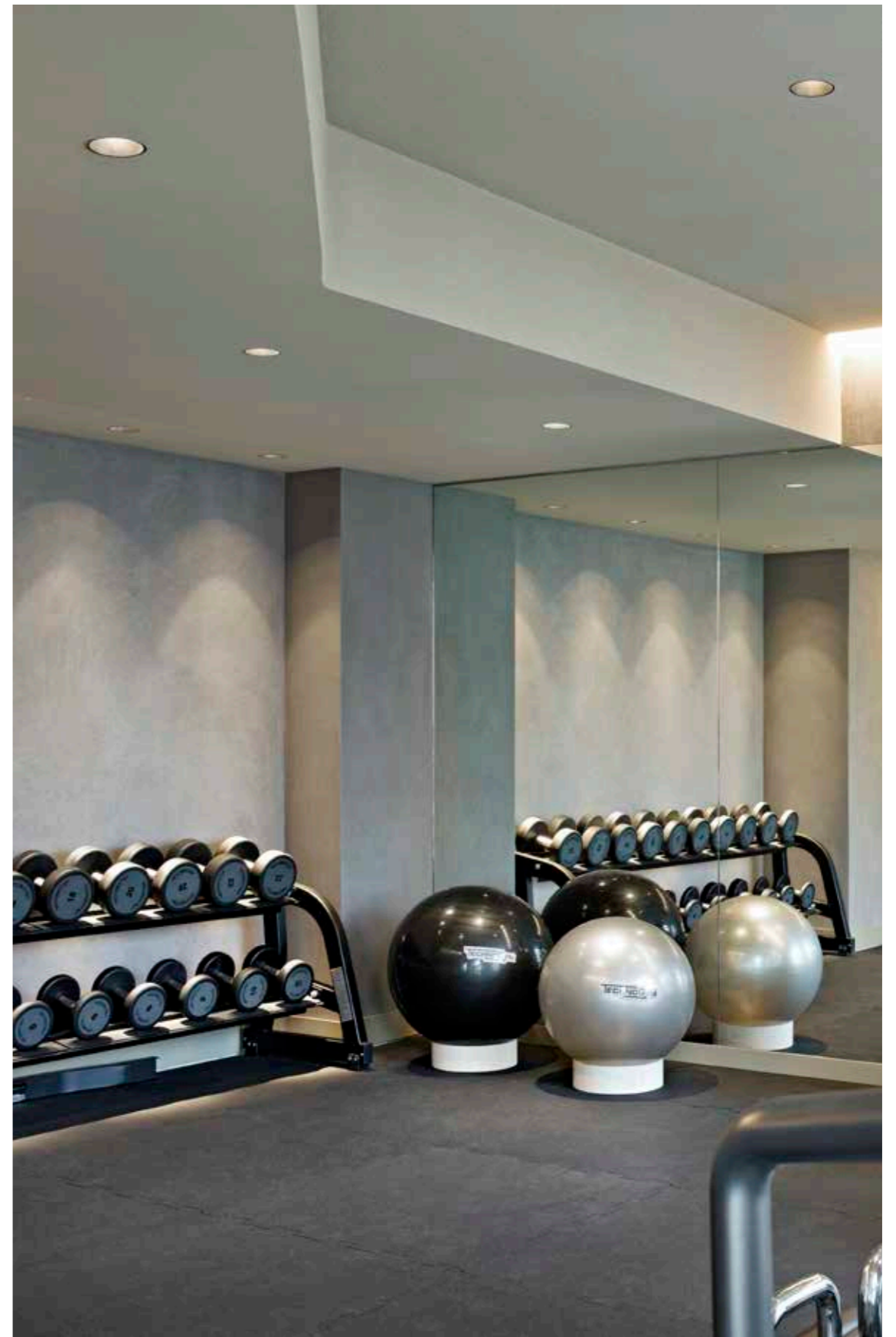

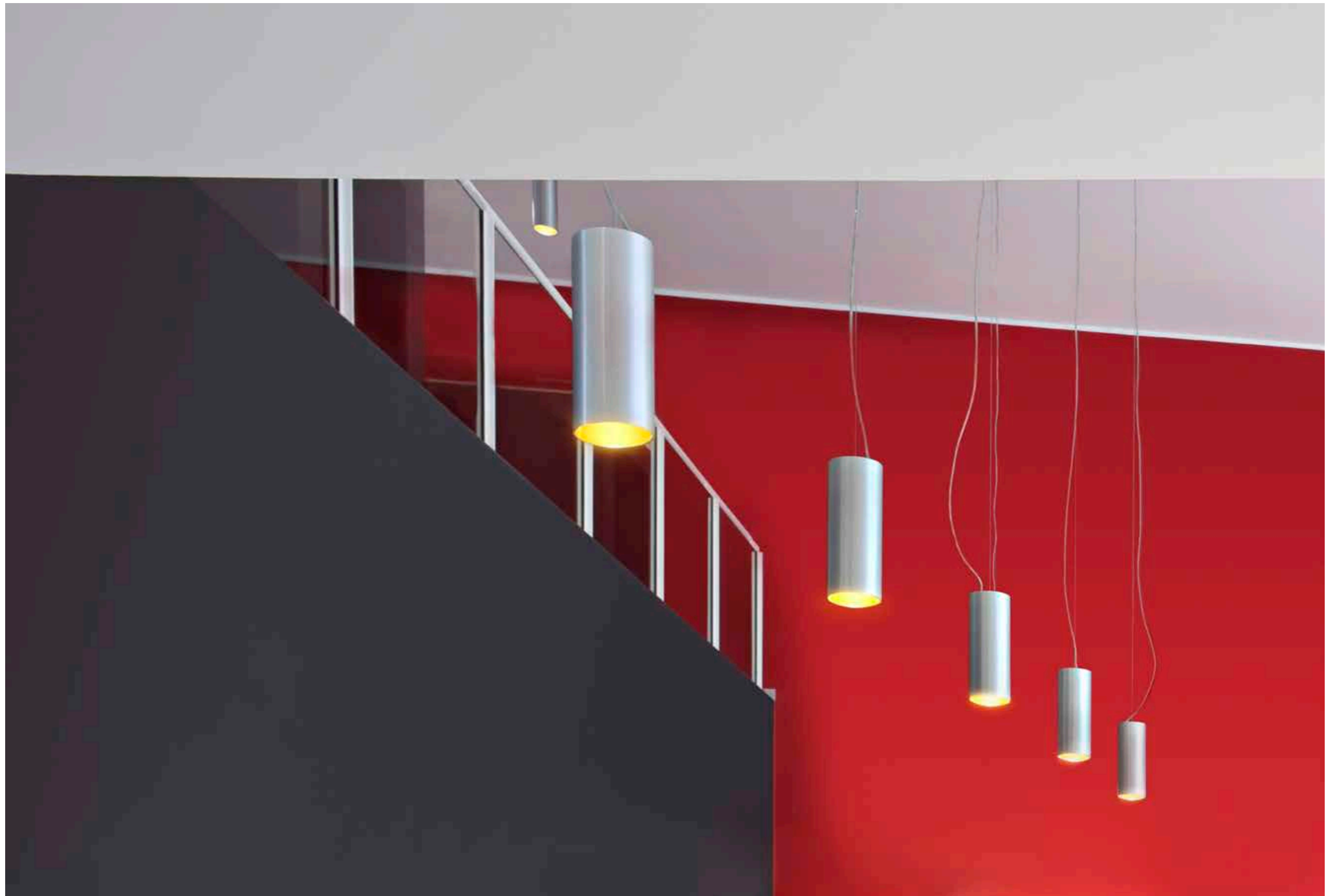



Die Leuchte enthält einen Diffusor aus Thermoplastkunststoff zur absolut gleichmäßiger Verteilung des Lichtes auf horizontalen Arbeitsflächen.

The luminaire includes a thermoplastic diffuser which ensures a perfect light distribution on horizontal surfaces.





KAP

KAP 80
FIXED



LED ARRAY
9,2W

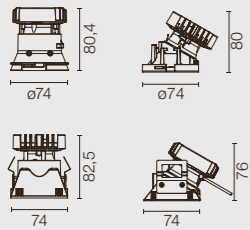

KAP 80
WALL-WASHER



QR-CBC 51
max 50W
- OR -
LED QR-CBC 51
max 8W

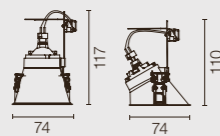

PAR 16
max 50W
- OR -
LED PAR 16
max 8W

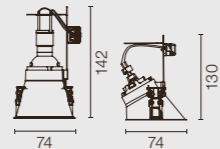

KAP 80
ADJUSTABLE



LED ARRAY
9,2W

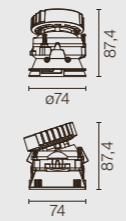

LED
QR-CBC 51
max 8W

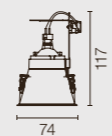

LED PAR 16
max 8W

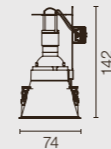

EASY KAP

EASY KAP 80
FIXED

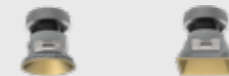

LED ARRAY
9,2W

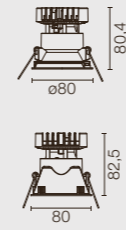

EASY KAP 80
ADJUSTABLE

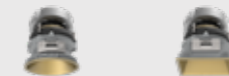

QR-CBC 51
*max 50W
- OR -
LED QR-CBC 51
max 8W

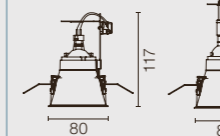

PAR 16
*max 50W
- OR -
LED PAR 16
max 8W

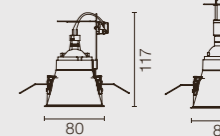

* Only Fixed / Wall-Washer version

KAP Ø105



PHOSPHOR
LED
15,6W

LED ARRAY
13,5W

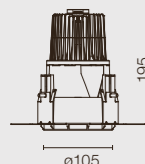

QT-12
max 50W

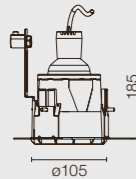

KAP 105 SQUARE



PHOSPHOR
LED
17W

LED ARRAY
17W

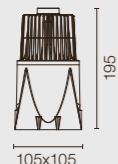

QR-CBC 51
max 50W
- OR -
LED QR-CBC 51
7W

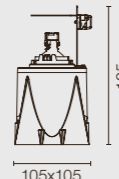

KAP Ø145



PHOSPHOR LED
17W

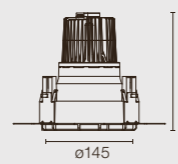

KAP Ø145
DEEP



LED ARRAY
17W

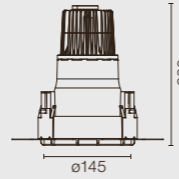

KAP Ø145
WALL-WASHER

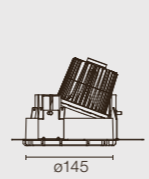

EASY KAP Ø105
FIXED



LED ARRAY
9,2W

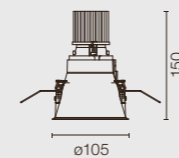

EASY KAP Ø105
WALL-WASHER



QR-CBC 51
max 50W
- OR -
LED QR-CBC 51
max 7W

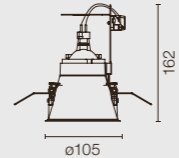

HI PAR 51
max 35W

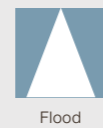
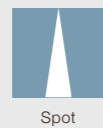
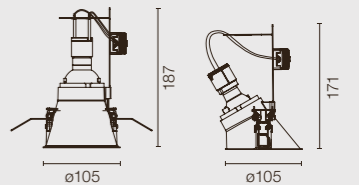

□ B1 Weiss
B1 White



■ GL Mattgold
GL Matt Gold



■ BU Blau
BU Blue



■ 74 Schwarz
74 Black



■ CU Kupfer
CU Copper



KAP SURFACE / SUSPENSION

| | | | | | | | |
|-------------------|-----------------|--------------|--------------------|-----------------|---------------------|--------------------|-----------------------|
| Ø80 ROUND | CEILING Ø100 | WALL Ø100 | SUSPENSION Ø100 | CEILING Ø115 | WALL Ø115 | SUSPENSION Ø115 | WALL Ø115 |
| | | | | | | | |
| 80 SQUARE | | | | | | | |
| | | | | | | | |
| LED ARRAY 9,2W | | | | | | | |
| | | | | | | | |
| | POWER LED 9W | | | | QT-14 max 48W ES | | QT-14 max 2x33W ES |
| | | | | | | | |
| | | | | | | | |



KAP SURFACE / SUSPENSION

KAP 80 ROUND / SQUARE

| | | | | |
|-----------------|----------------------|------------------------|--------------------------------|------------------|
| Außen / Outside | 11 Weiss 11 White | AN Schwarz AN Black | 18 Deep Brown 18 Deep Brown | |
| Innen / Inside | Weiss White | Mattgold Matt Gold | Kupfer Copper | Schwarz Black |

KAP Ø100 / Ø115

| | | | | |
|-----------------|----------------------|--|------------------------|----------------------|
| Außen / Outside | 11 Weiss 11 White | AS Gebürstetes Aluminium AS Brushed Aluminium | AN Schwarz AN Black | B3 Braun B3 Brown |
| Innen / Inside | Weiss White | Mattgold Matt Gold | Blau Blue | Schwarz Black |



TUBULAR BELLS

Kollektion minimalistischer und robuster Leuchten mit hoher Effizienz und hoher Lichtleistung. Die Produktfamilie besteht aus LED-Beleuchtungsgeräten für Deckeninstallationen und beinhaltet auch die Variante für die Aufhängung.

TUBULAR BELLS

Collection of robust minimalist lamps with high efficiency and lighting power. The family includes direct LED lighting devices for ceiling installation and also includes the suspended variant.



DESIGNED BY PIERO LISSONI



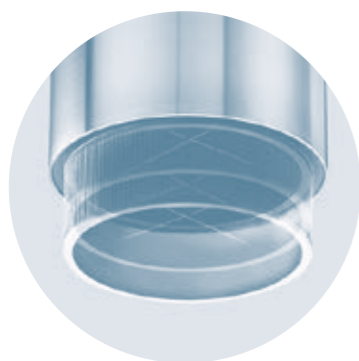
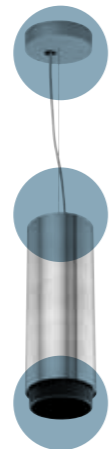

Der Hauptkörper der Leuchte enthält einen verstellbaren Abschirmzylinder, der die Blendung des Optikkörpers verringert.

The main body of the luminaire is provided with an adjustable cylindrical screen that reduces the glaring effect of the optical body.

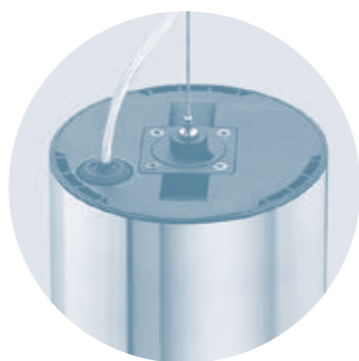

Die Leuchte verfügt über ein verstellbares System zur Befestigung des Hänge-seils, das eine perfekte Installation auf der Vertikalachse ermöglicht.

The luminaire is provided with an adjustable fastener for the suspension line that allows a perfect installation on the vertical axis.

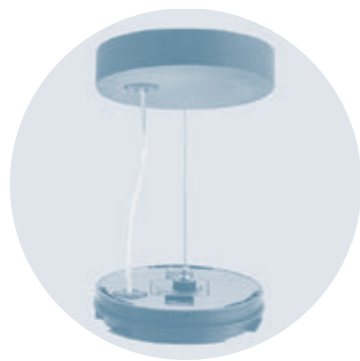

Zubehör für Hängeausführung.

Suspended installation accessory.



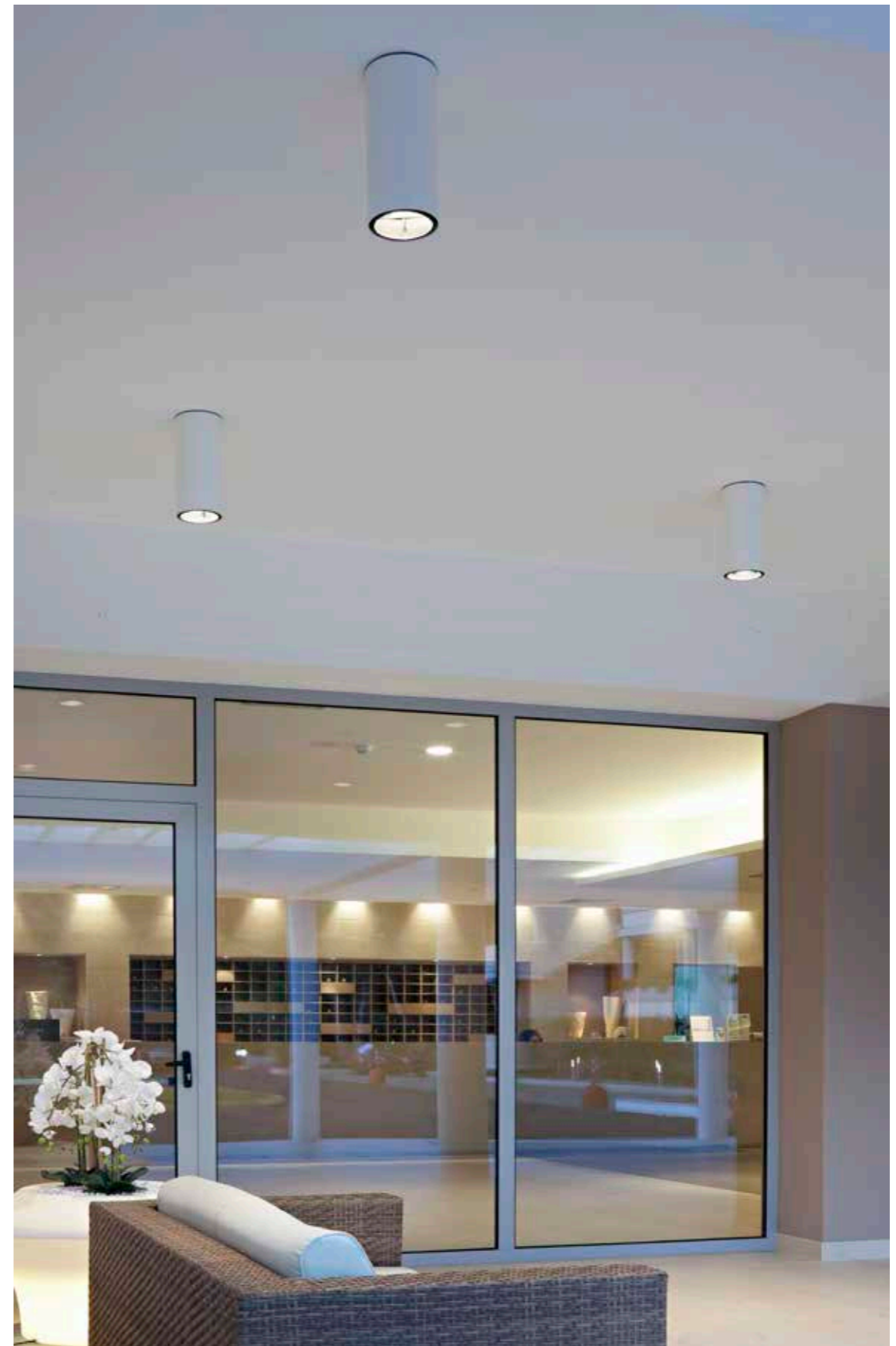

TUBULAR BELLS



TUBULAR BELLS

CEILING



SUSPENSION



WALL



PHOSPHOR LED
7,4W

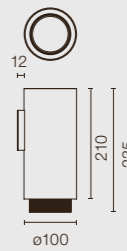
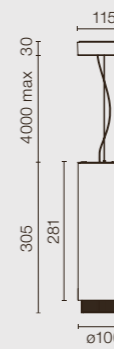
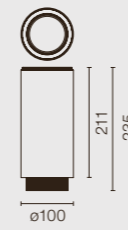

Spot



Flood

□ 11 Weiss
11 White



▨ AS Gebürstetes Aluminium
AS Brushed Aluminium



■ AN Schwarz Eloxiert
AN Anodized Black



Leuchtenkollektion für alle lichttechnischen Anforderungen im Wohnbereich und im professionellen, hochspezialisierten Kontext wie Büros, Gewerberäumen und Empfangsbereichen. Light Sniper bietet Einbauleuchten für Akzentbeleuchtung, feste und schwenkbare Versionen sowie Wallwasher. Bei den Lichtquellen ist auch LED inbegriffen.

LIGHT SNIPER

Collection of devices to satisfy all the lumino-technical demands that might arise both in residential applications and in highly professional and specialised contexts, such as offices, shopping areas and reception areas. Light Sniper has recessed devices for accent lighting, which can be fixed, directional or wallwashers. It is available in LED as well as other light sources.







Der Optikkörper enthält einen Reflektor, der die Lichtblendung verringert.

The optical body includes a reflector that reduces the glaring effect of the lamp.



Der Blendungsschirm der Leuchte ist in drei Farben verfügbar: Mattschwarz, Gold und Chrom.

The anti-glare screen of the luminaire is available with three different colours: dull black, gold and chrome.



Die Leuchte enthält in ihrem Hauptkörper ein Kühlelement zur Temperaturkontrolle.

The main body of the luminaire contains a radiator for temperature control.



Die Druckverschlüsselemente aus Edelstahl ermöglichen den Lampenaustausch ohne Hilfe von Werkzeugen.

Thanks to the pressure clips made of stainless steel, it is possible to replace the lamp without using any particular tool.

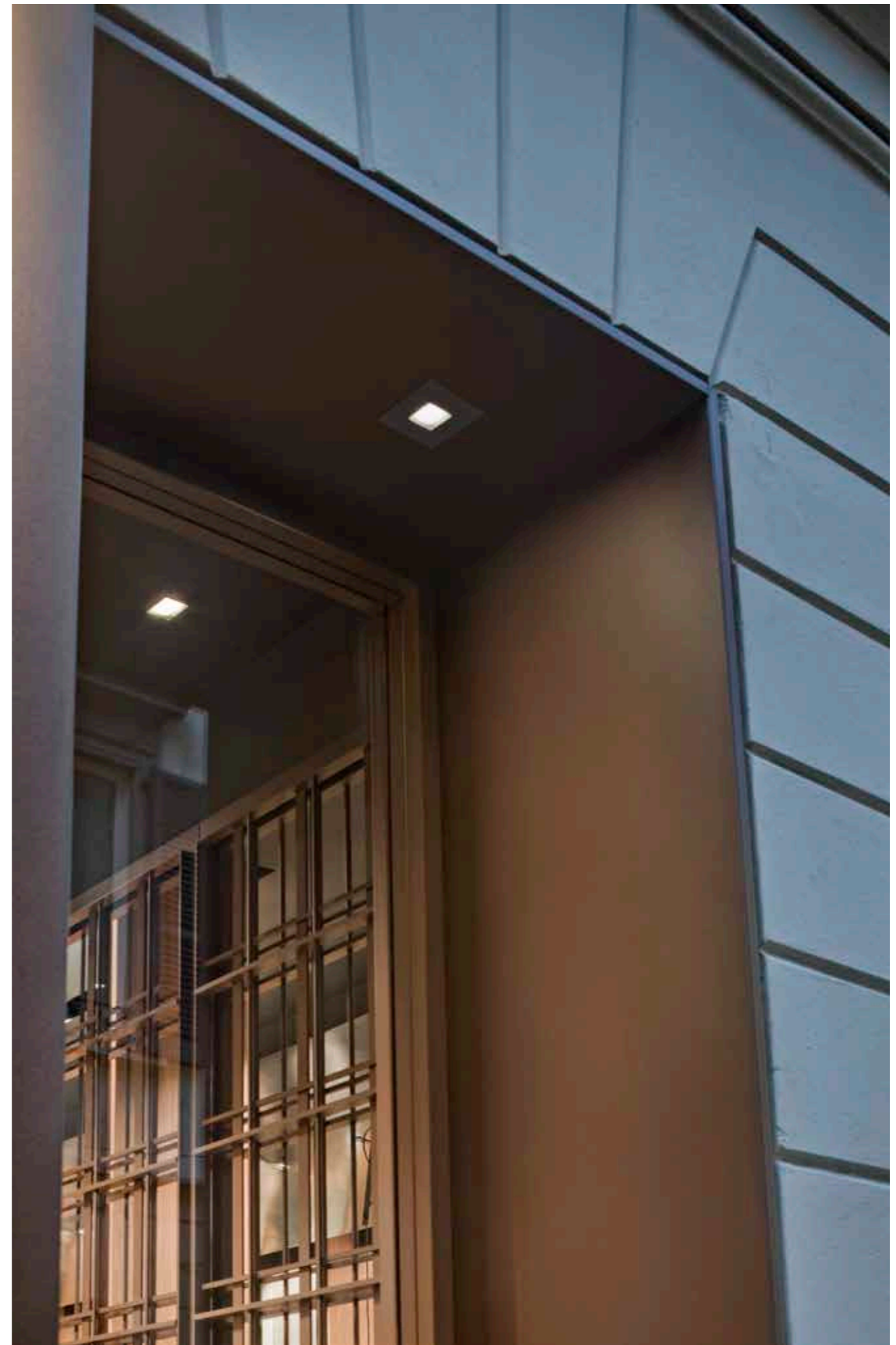



LIGHT SNIPER

FIXED



ADJUSTABLE

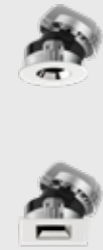

WALL-WASHER

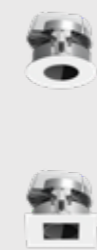

FIXED



ADJUSTABLE



POWER LED
11W

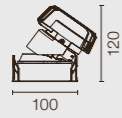

PHOSPHOR LED
9W

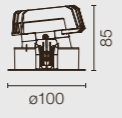
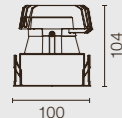

LIGHT SNIPER

06 Chrom
06 Chrome

GL Mattgold
GL Matt Gold

14 Mattschwarz
14 Matt Black



Drehbar um 360° und schwenkbar 35°.
Can be rotated 360° and swivelled 35°.

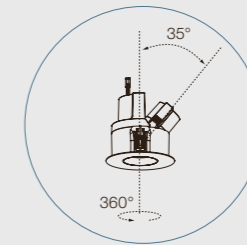

FIXED



QR-CBC 51
max 35W
- OR -
LED QR-CBC 51
7W

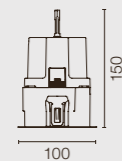

ADJUSTABLE



QR-CBC 51
max 50W
- OR -
LED QR-CBC 51
7/10W

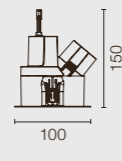

WALL-WASHER



QR-CBC 51
max 50W

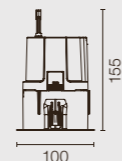

Ein umfassendes Angebot an einbaufähigen LEDs, deren konisches Design einen hohen Sichtkomfort, Energieeffizienz, eine einfache Montage und unauffällige Integration in die Raumgestaltung ermöglicht. Durch den Einsatz der modernsten auf dem Markt erhältlichen LED-Module wird eine zuverlässige, brillante Lichtqualität gewährleistet. Das umfassende Angebot an Optiken mit 30° Einsparung und unterschiedliche Installationsarten für jede Beleuchtungsanforderung ermöglichen eine makellose Montage in jedem Medium und jeder Umgebung, selbst bei doppelter Deckenhöhe. Der verstellbare Light Shooter bietet ein präzises, zuverlässiges System für die Neigung und Drehung auch nach der Installation.

LIGHT SHOOTER

A complete range of recessed LED downlights whose compact conical design delivers excellent visual comfort, energy efficiency, easy installation and good architectural integration. Mount the most advanced LED modules on the market to ensure reliable, top quality light. A full range of optics with a 30° cut-off, various installation solutions cover any lighting need, allowing flawless installation in any material and environment, even with double height ceilings. The adjustable Light Shooter also features a precise and reliable tilt and rotation system, even when the product is already in position.



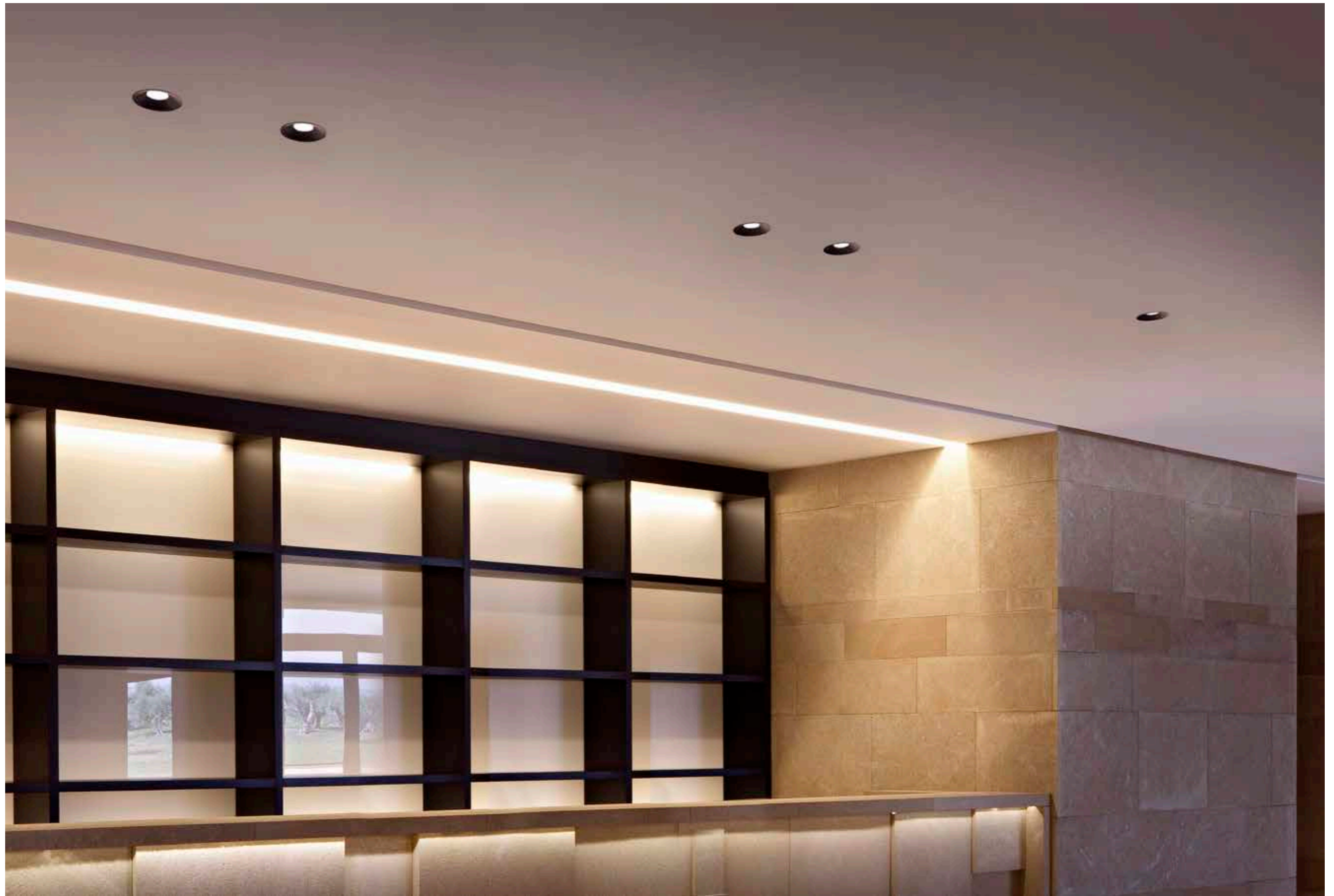

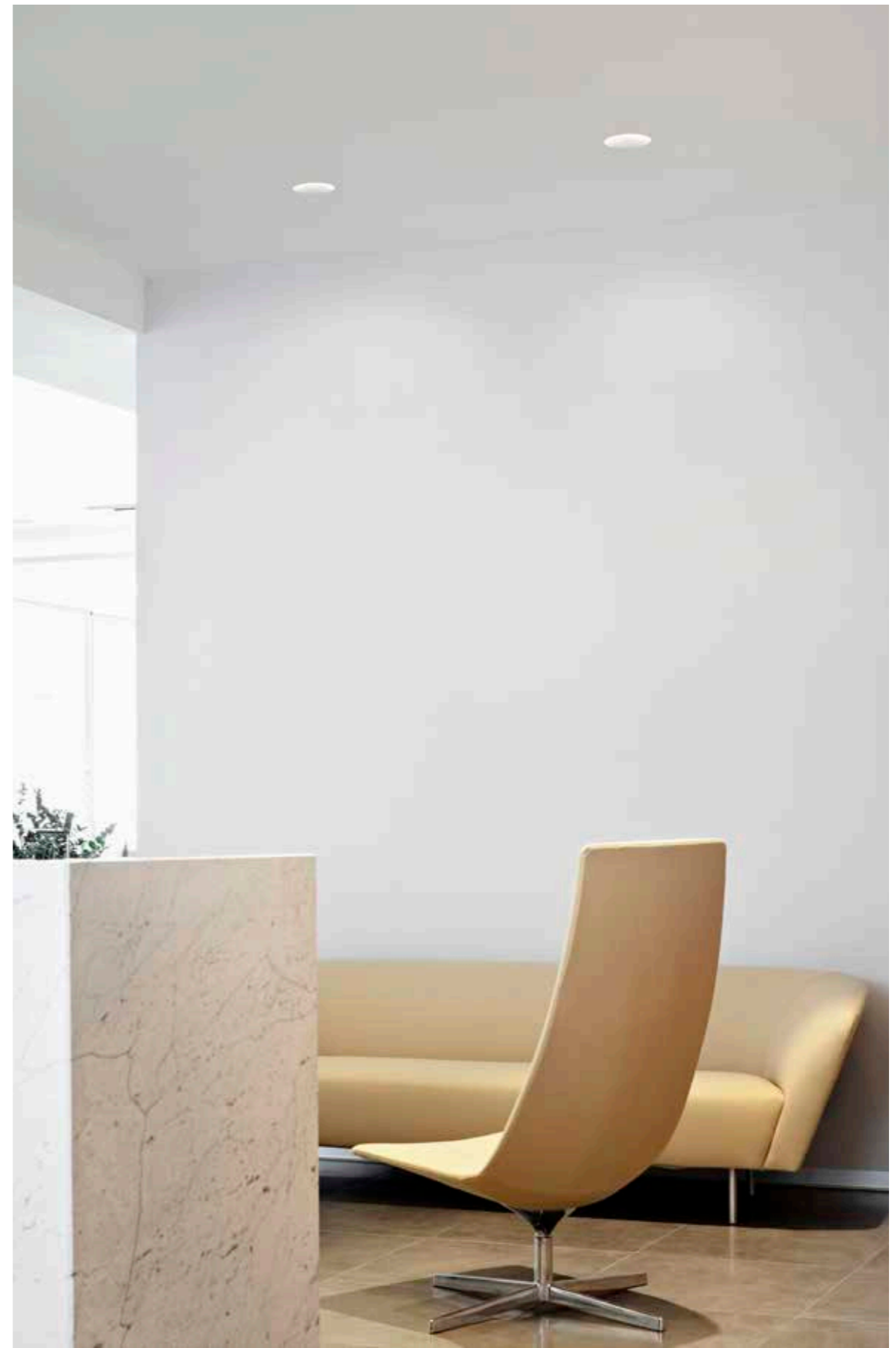
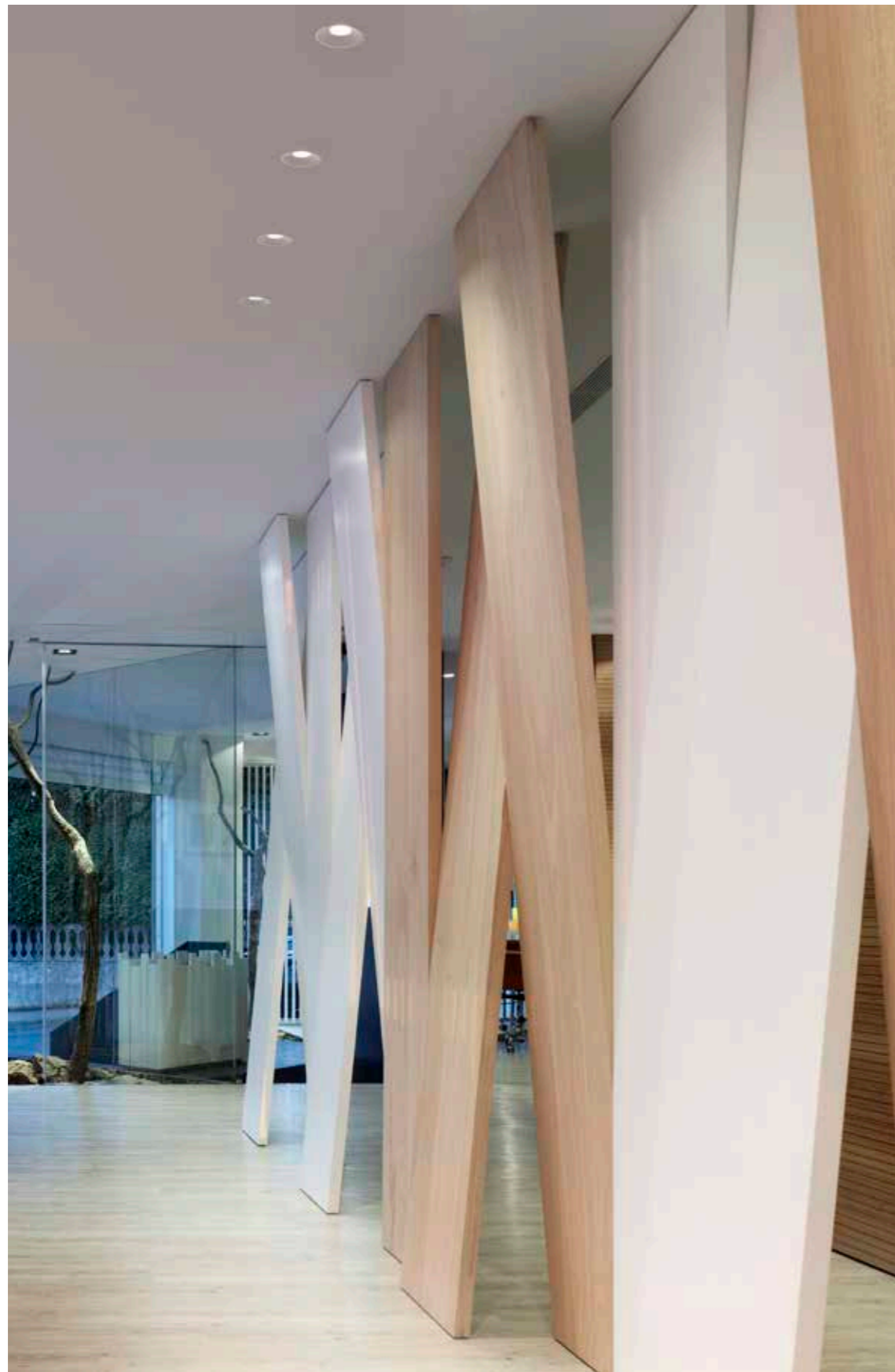



LIGHT SHOOTER

FIXED
TRIM / NO TRIM



ADJUSTABLE
TRIM / NO TRIM



WALL-WASHER
TRIM / NO TRIM



EASY ADJUSTABLE
TRIM



POWER LED
10W

HIGH POWER LED
11W

LED QR-CBC 51
max 10W

LED PAR 16
max 10W

TRIM

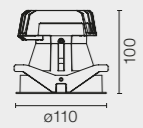

TRIM

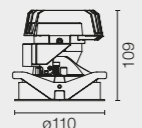

TRIM

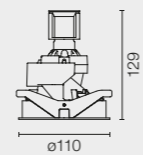
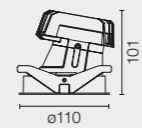

NO TRIM

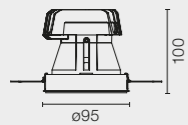

NO TRIM

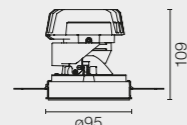

NO TRIM



Spot



Flood

LIGHT SHOOTER

40 Weiss
40 White

14 Schwarz
14 Black



Drehbar um 360° und schwenkbar 40°.
Can be rotated 360° and swivelled 40°.

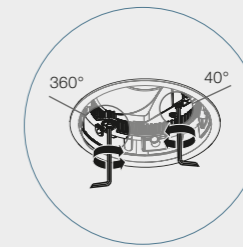
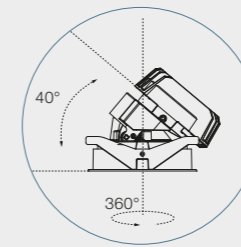

IP54

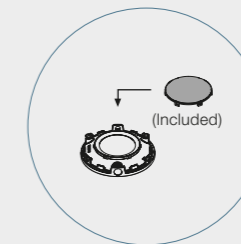

(Included)

LIGHT SUPPLY

Leistungsstarke Einbauleuchten mit LED-Modulen der neuesten Generation. Kompakte Größe, die eine optimale Integration in die Architektur ermöglicht. Erhältlich als feste, verstellbare und Wall-Washer Modelle sowie mit professionellem Abschirmzubehör.

LIGHT SUPPLY

High-power recessed elements with avant-garde LED modules. Compact size with maximum integration into the architecture. Comes in fixed, wall-washer and adjustable versions, with professional screening accessories.



DESIGNED BY FLOS ARCHITECTURAL





FIXED
TRIM / NO TRIM



PHOSPHOR LED
26W
28W

LED ARRAY
HIGH PERFORMANCES
29W

TRIM

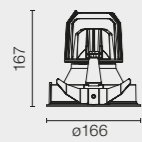

NO TRIM

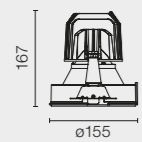

ADJUSTABLE
TRIM / NO TRIM



PHOSPHOR LED
26W
28W

LED ARRAY
HIGH PERFORMANCES
30,1W

TRIM

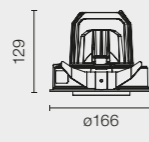

NO TRIM

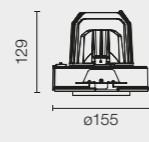

WALL-WASHER
TRIM / NO TRIM



PHOSPHOR LED
26W
28W

LED ARRAY
HIGH PERFORMANCES
33,2W

TRIM

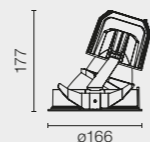

NO TRIM

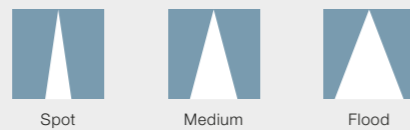
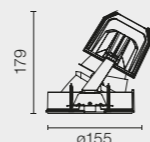

Adjustable

40 Weiss
40 White

14 Schwarz
14 Black



Fixed & Wall-Washer Trim

Außenring
External Ring

Weiss
White

Schwarz
Black

Reflektor
Reflector

Aluminium
Aluminium

Weiss
White

Aluminium
Aluminium

Weiss
White



Drehbar um 365° und schwenkbar 35°.
Can be rotated 365° and swivelled 35°.

Light Supply Adjustable

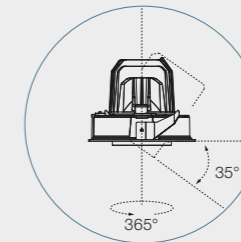

JOHNNY

Vielseitiger Strahler dank der beiden verfügbaren Größen und der Fülle an Installationsmöglichkeiten. Maximale Integration als Einbaumodell und optimale ästhetische Präsenz des aus exklusiven Materialien gefertigten Halbeinbaumodells. Ausgestattet mit einem mechanischen Drehsystem, das Leistung, Integration und dauerhafte Widerstandsfähigkeit gewährleistet. Enthält auch Modelle für die rahmenlose Schnellinstallation mit unserem Fast&Perfect Installationssystem.

JOHNNY

Versatile projector thanks to the two available sizes and the great variety of installation possibilities. Possibility of maximum integration in the recessed version, or of a stranger aesthetic presence in the semi-recessed versions with exclusive finishes. Fitted with a mechanical rotation system that ensures efficiency, integration and stability over time. Includes different versions for a fast frame-free installation with the Fast&Perfect system.



DESIGNED BY FLOS ARCHITECTURAL







Johnny 80/Johnny 80 Halbeinbau: Kippbares Ausrichtungssystem, bei dem zur optimalen Ausrichtung der Strahlerkopf herausgezogen und gekippt werden kann.

Johnny 120/Johnny 120 Halbeinbau: Mechanisches Ausrichtungssystem, bei dem zur optimalen Ausrichtung der Strahlerkopf entfernt werden kann.

Johnny 80 / Johnny 80 Semi-recessed: with the tilt orientation system the spotlight head can be pulled and tilted in the desired direction.

Johnny 120 / Johnny 120 Semi-recessed: a mechanic orientation system that enables pulling the head out of the projector for a correct orientation.

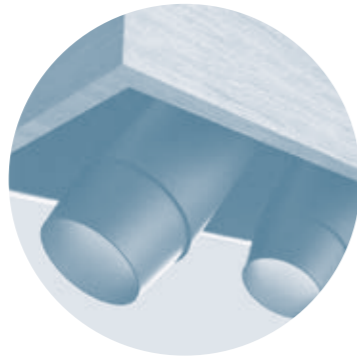

Konische Abschirmung verfügbar.

Conical shield accessory available.



Box für den Halbeinbau. Je nach Modellversion in den Ausführungen Zement, Teak, Weiß oder Schwarz erhältlich.

Box for semi-embedded installation. Available with cement, teak, white or black finishes, according to the versions.

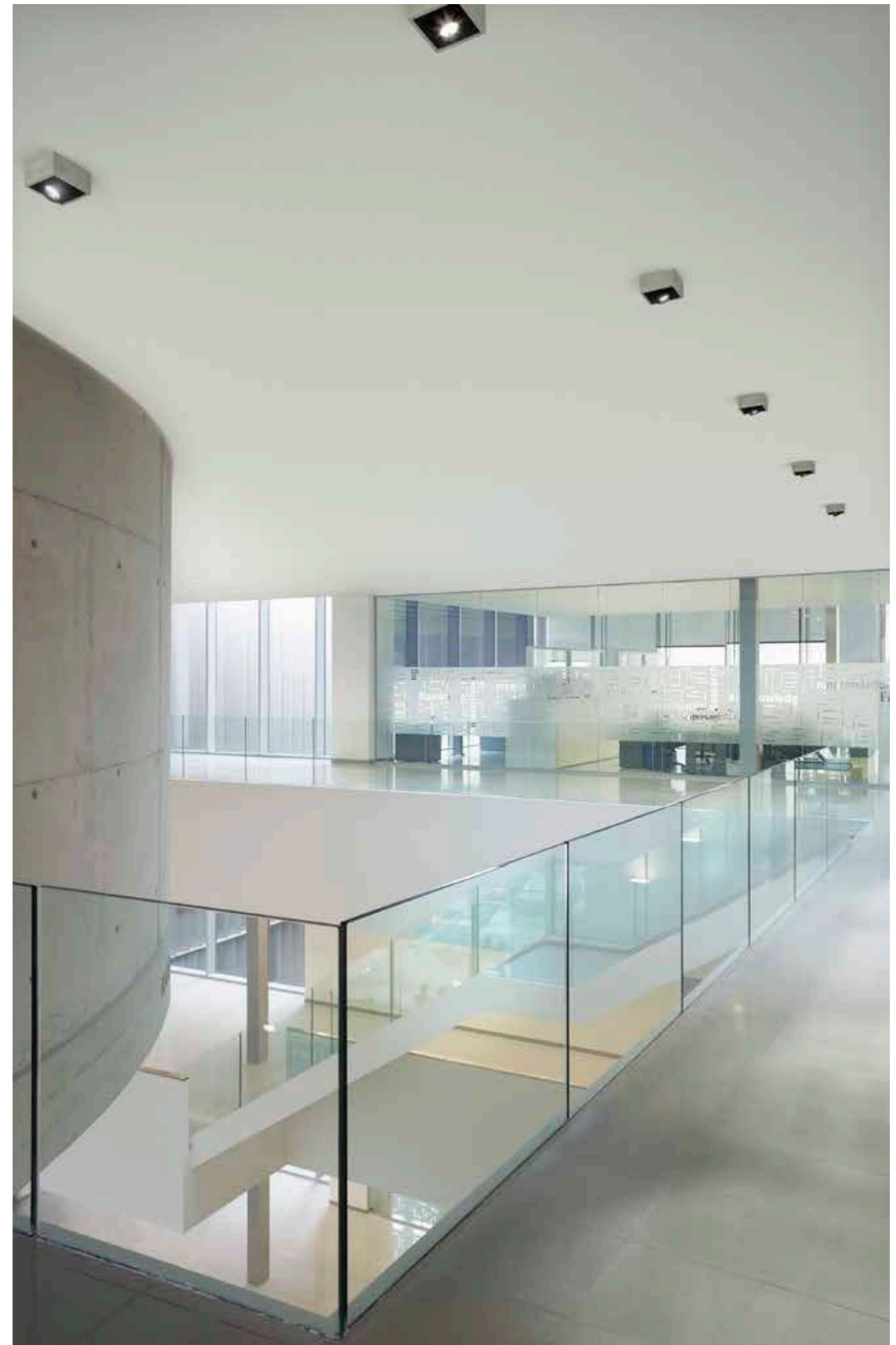



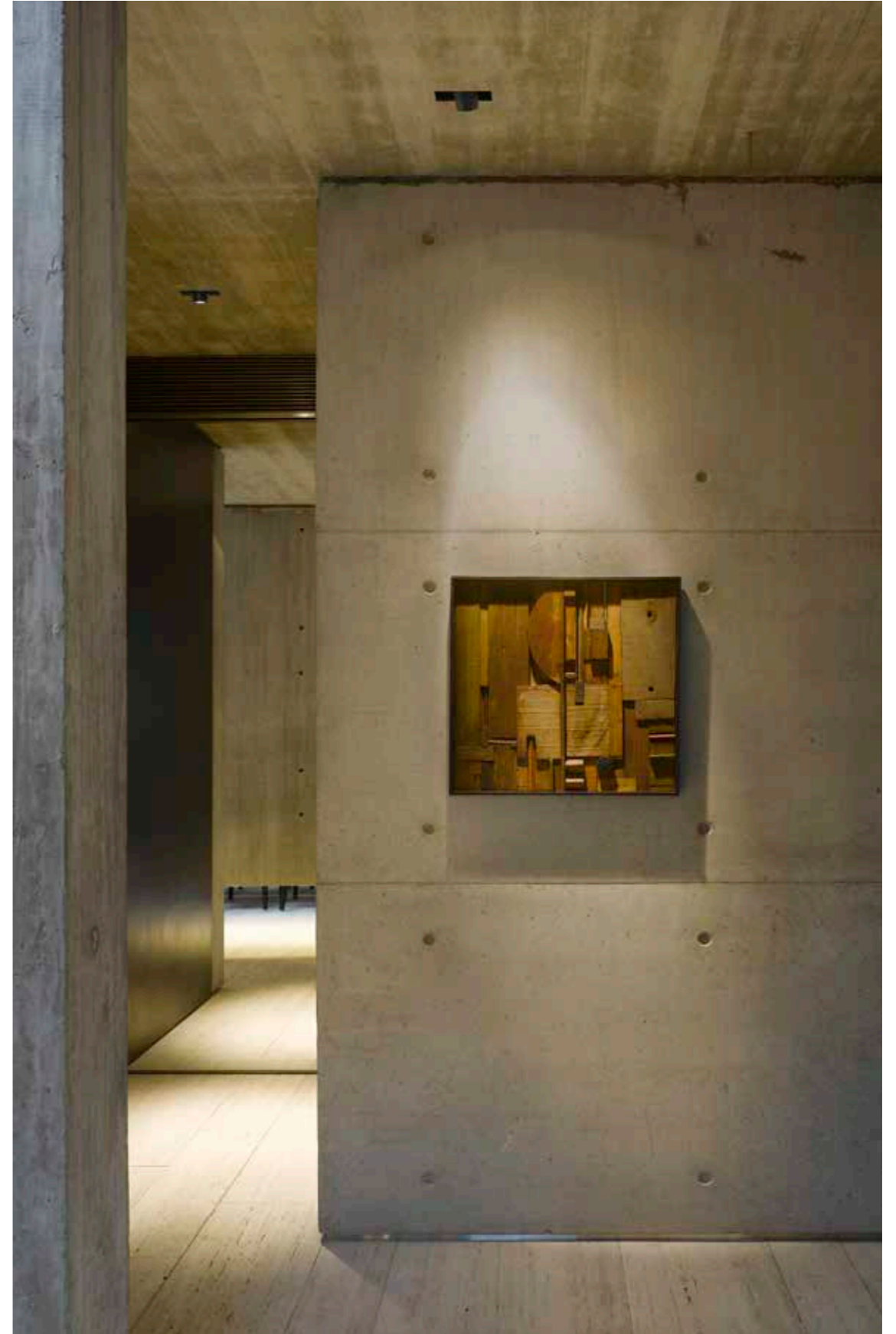
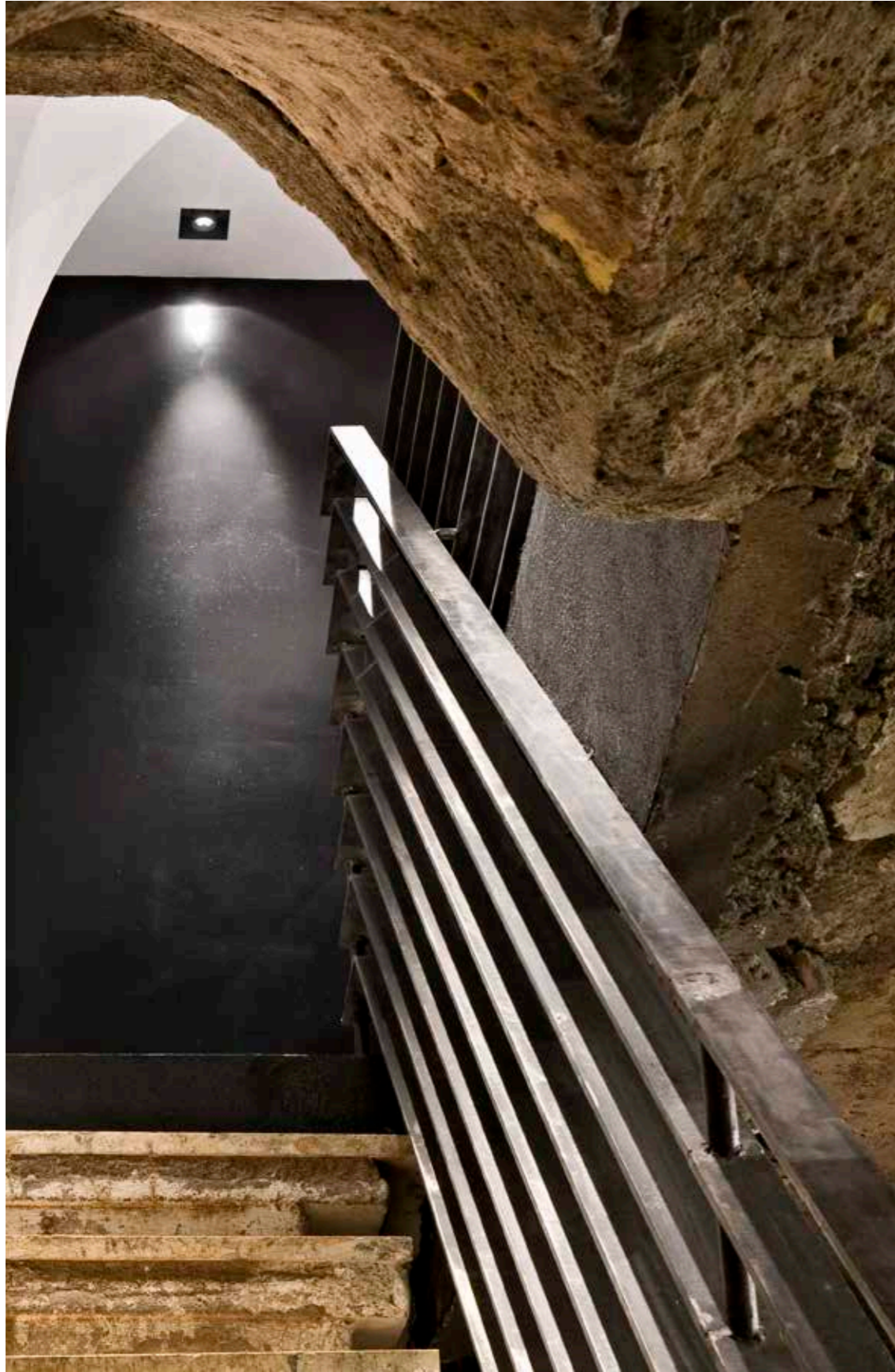

TRIM / NO TRIM
1L ROUND 1L/2L SQUARE



SEMI-RECESSED
1L/2L SQUARE



TRIM



NO TRIM



POWER LED
6,2W

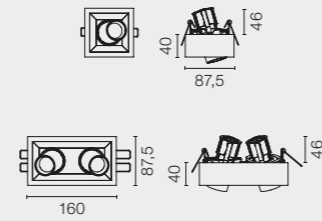

Trim / No Trim

40 Weiss 40 White 14 Schwarz 14 Black

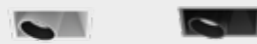

Innen / Inside

Weiss White Schwarz Black

Außen / Outside

40 Weiss 40 White CE Zement CE Concrete TK Teak-Holz TK Teak 14 Schwarz 14 Black

Semi-Recessed

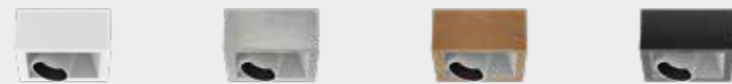

Ist bis in alle Richtungen hin schwenkbar.
Can be rotated in any direction.

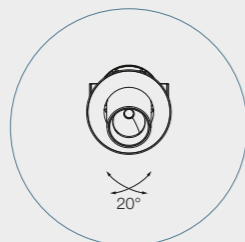

TRIM / NO TRIM
1L ROUND 1L/2L SQUARE



SEMI-RECESSED
1L/2L SQUARE



LED ARRAY
LED ARRAY HIGH PERFORMANCE
18W

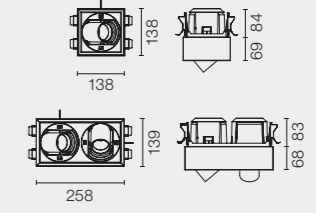

Trim

Weiss White Schwarz Black



No Trim

Schwarz Black



Innen / Inside

Weiss White Schwarz Black

Außen / Outside

40 Weiss 40 White CE Zement CE Concrete TK Teak-Holz TK Teak 14 Schwarz 14 Black

Semi-Recessed



Ist bis in alle Richtungen hin schwenkbar.
Can be rotated in any direction.

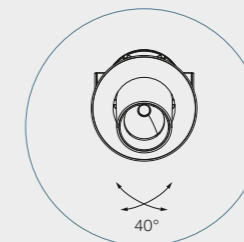

Produktreihe von schwenkbaren Beleuchtungsgeräten für Oberflächen- und Einbauinstallationen. Vorbereitet für Halogenlampen und LEDs der neuesten Generation. Die große Vielfalt an Ausführungen macht die Compass Box zu einer nützlichen Ergänzung in der Dekoration.

COMPASS BOX

Family of directable lighting devices for surface and recessed installations. Designed for the latest generation halogen and LED lamps. The wide variety of finishes available also make the Compass Box stand out as an additional decoration tool.





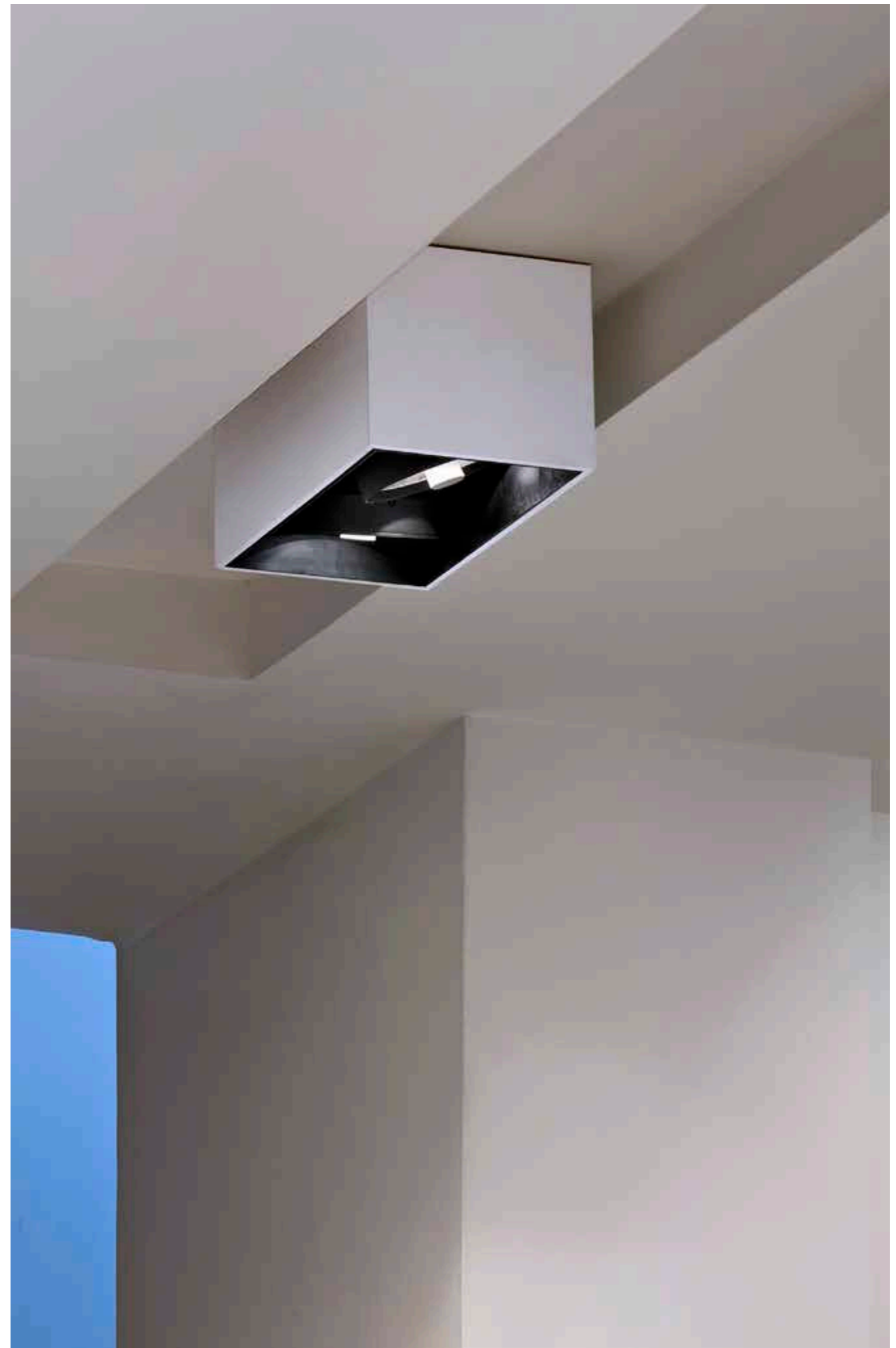
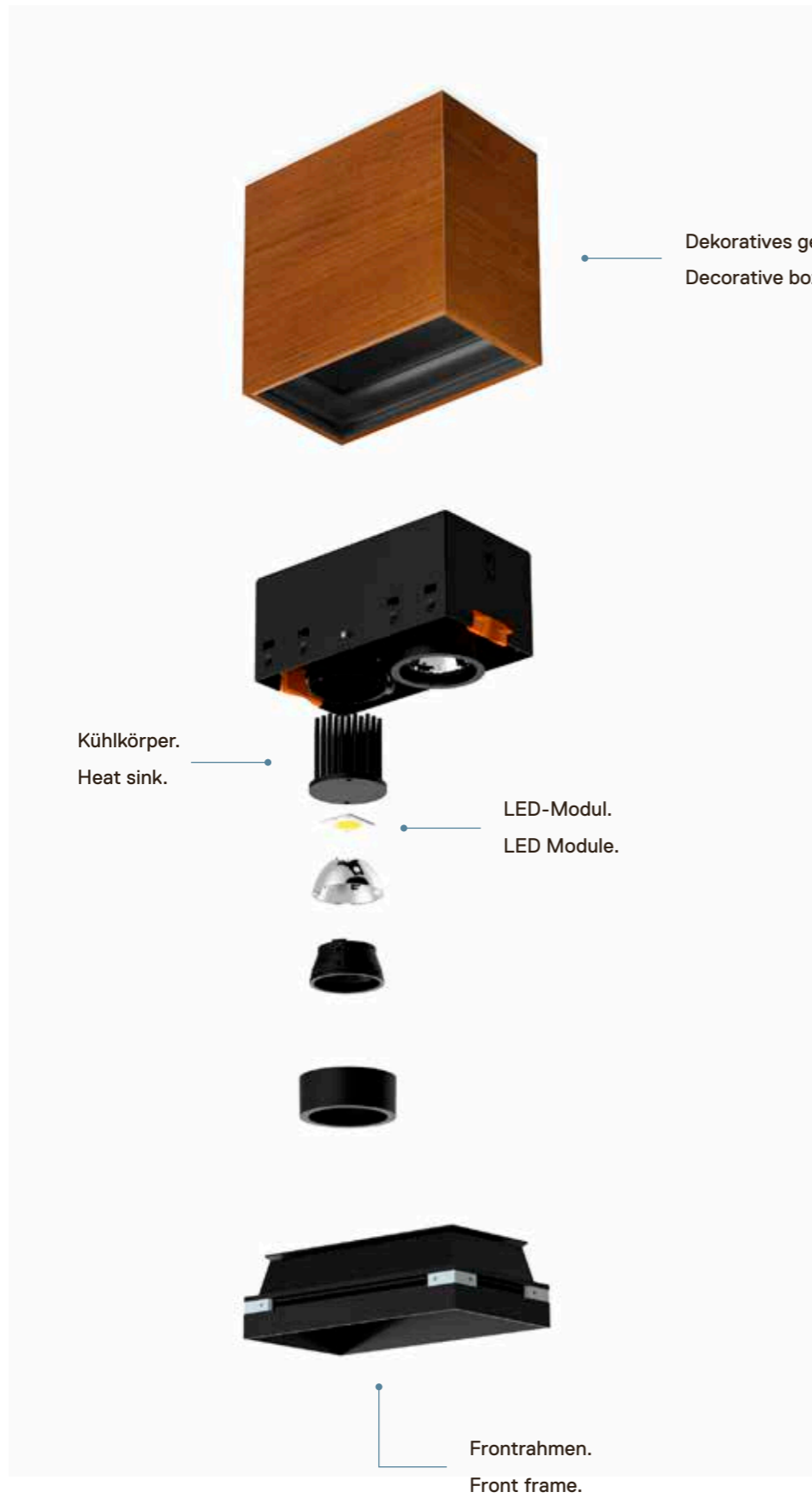





Das kardanische Ausrichtsystem aus Stahl ermöglicht die Ausrichtung der Leuchte in jede Richtung und auf allen Schwenkachsen. Eingebauter Optikkörper, der die Lichtblendung verringert.

The compass adjustment system made of steel allows the adjustment of the lamp in any directions and on any rotation axes. Recessed optical body which reduces the glaring effect of the lamp.





504

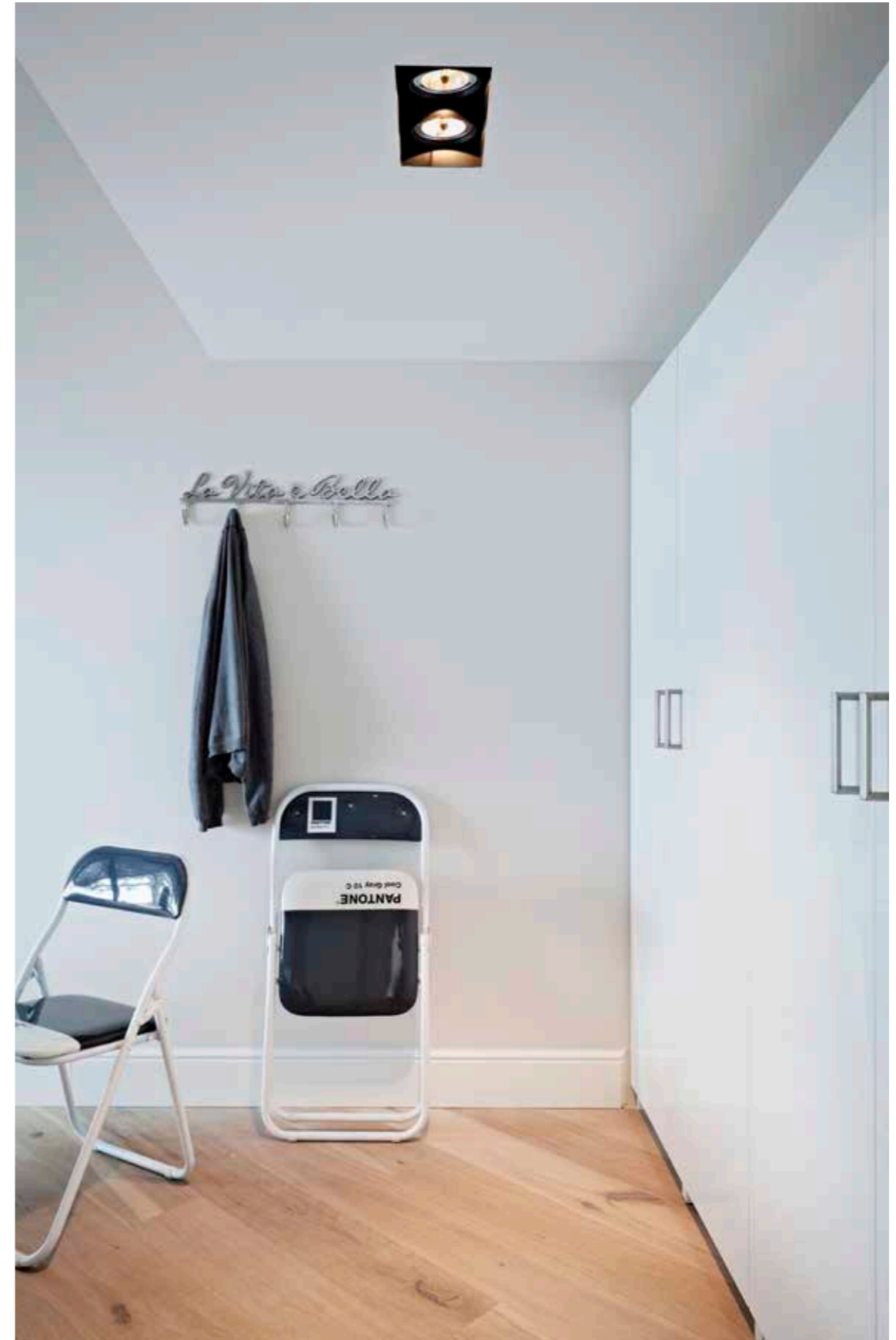

505

COMPASS BOX SURFACE

SMALL
1L / 2L / 4L /
4L SQUARE

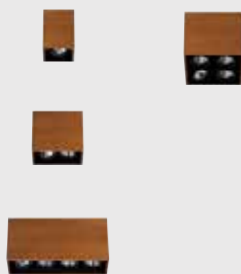

LED ARRAY
6,2W

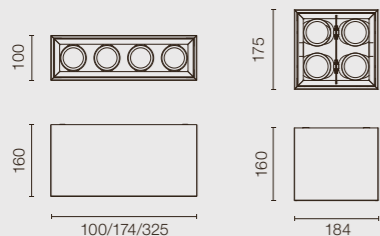

SMALL
1L / 2L / 4L

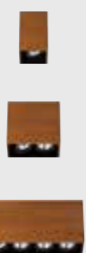

QR-CBC 51
max 35W
- OR -
LED QR-CBC 51
7/10W

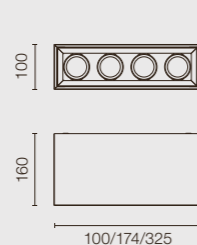

LARGE H:135
1L / 2L / 4L /
4L SQUARE

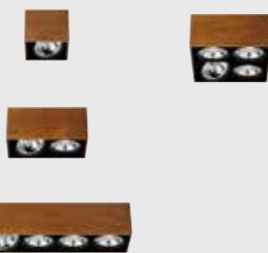

QR-111
max 75W
- OR -
LED QR-111

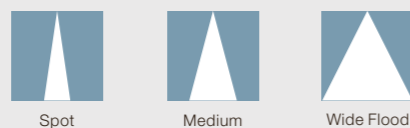
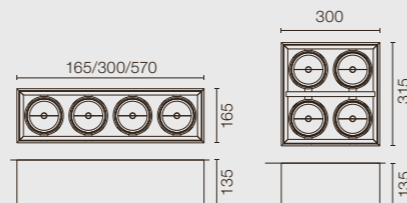

Spot Medium Wide Flood

- 30 Mattweiss
30 Matt White
- WG Wenge
WG Wenge
- 14 Mattschwarz
14 Matt Black
- TK Teak-Holz
TK Teak
- 29 Eloxiertes Aluminium
29 Anodized Aluminium



Schwenkbar um 20°.
Can be swivelled 20°.

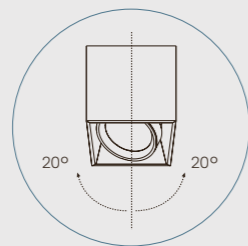

506

COMPASS BOX RECESSED

SMALL 1L / 2L



LED ARRAY
9,2W



SMALL 1L / 2L



QR-CBC 51
max 50W
- OR -
LED QR-CBC 51
7/10W

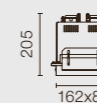

LARGE 1L / 2L



QR-111
max 100W
- OR -
LED QR-111

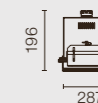

Spot Medium Wide Flood

- 30 Mattweiss
30 Matt White
- 14 Mattschwarz
14 Matt Black

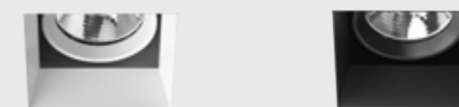

Schwenkbar um 20°.
Can be swivelled 20°.

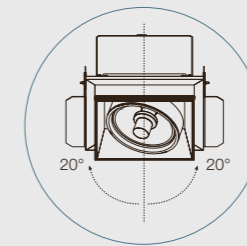

507

BATTERY

Familie von Einbauleuchten, die in unterschiedlichen Größen mit oder ohne Rahmen verfügbar sind und eine in der Umgebung integrierte Lösung für direkte Akzentbeleuchtung mit vielseitigem und eindrucksvollem Effekt bieten.

BATTERY

Family of recessed lighting devices, offered in different-sized modules, Trim and Non-Trim, becoming a solution that is integrated into the environment to provide efficient and versatile accent lighting.

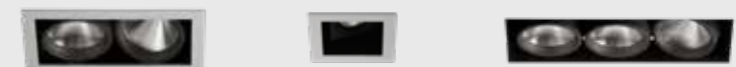

DESIGNED BY F.A. PORSCHE



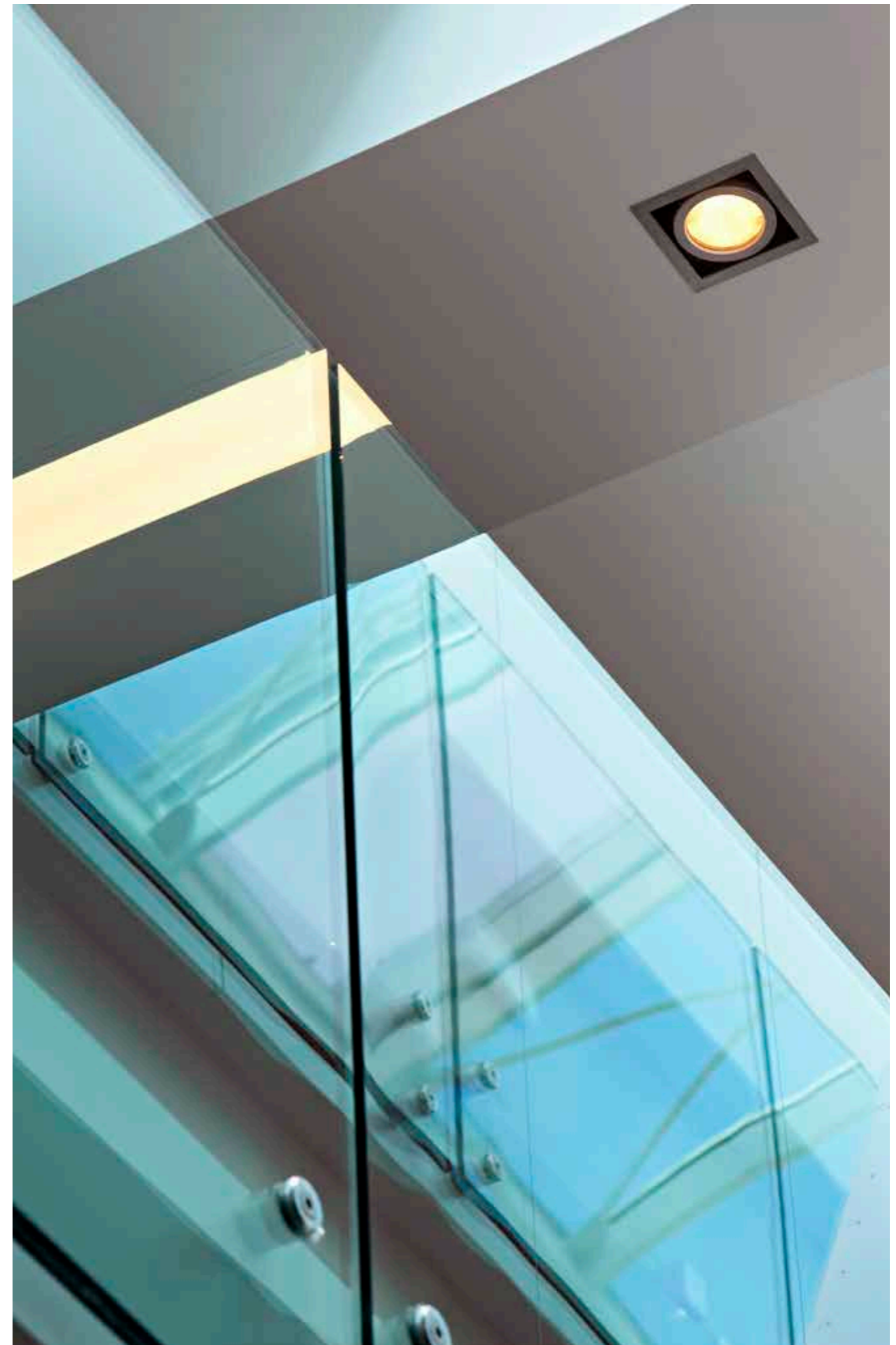
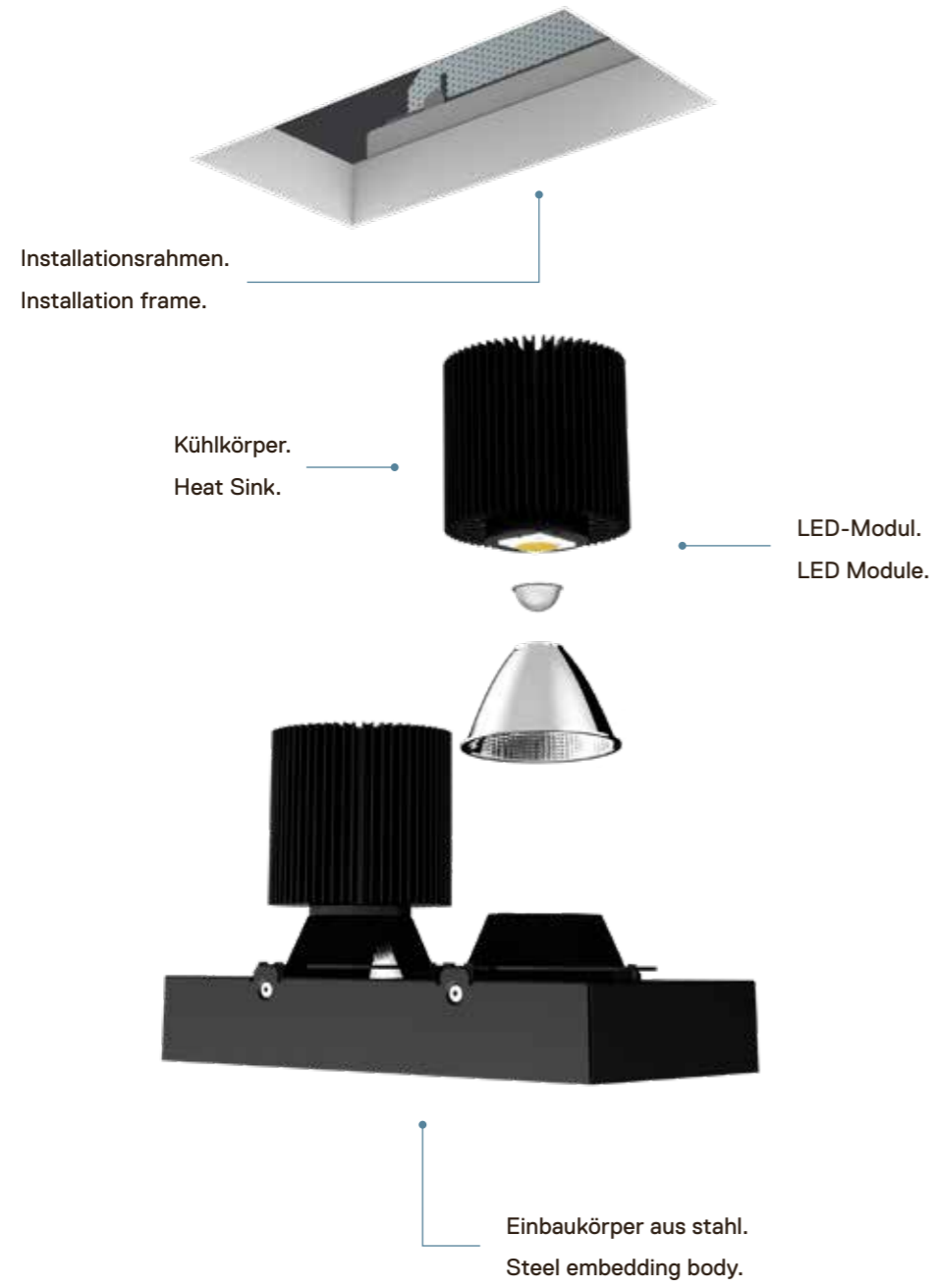



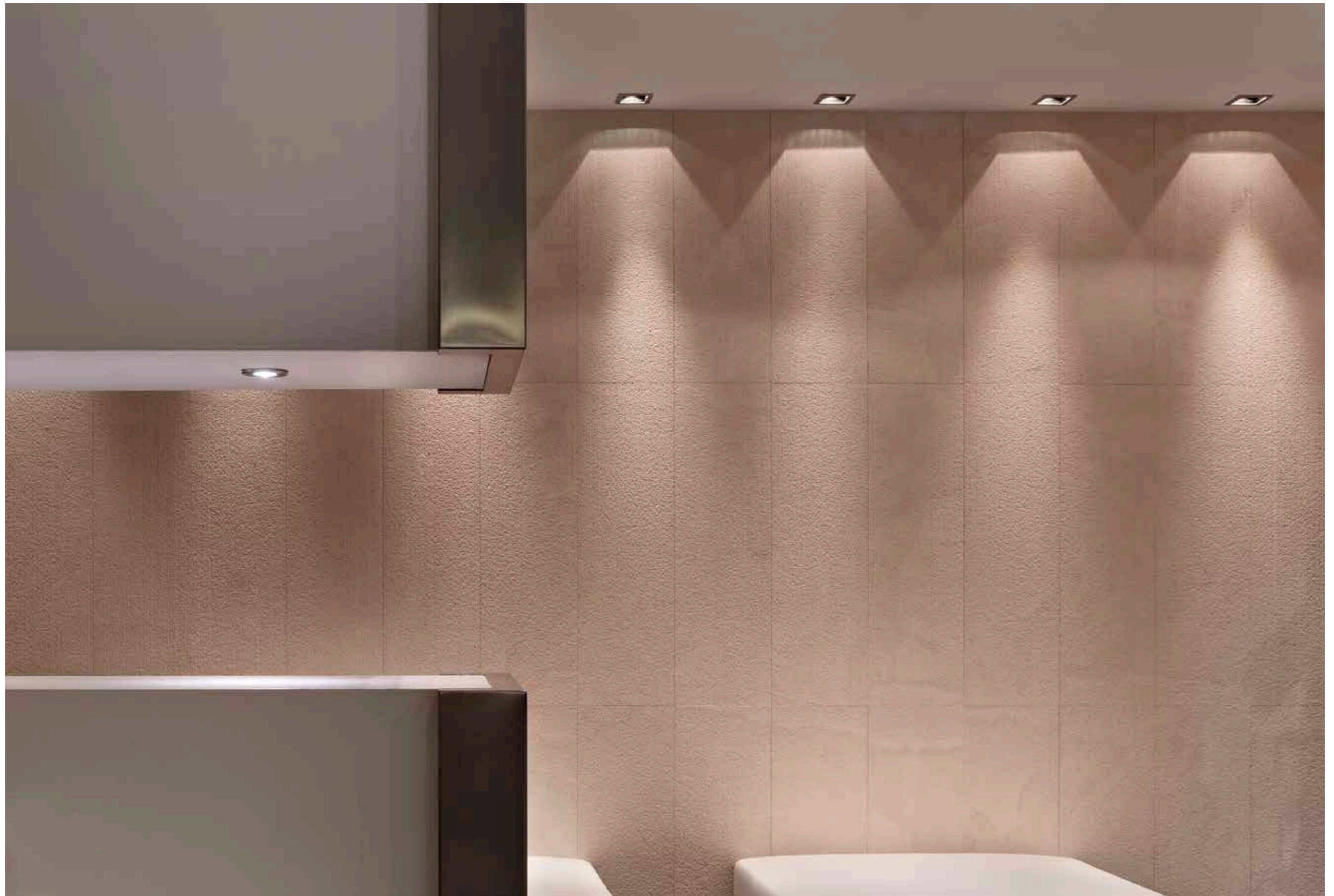

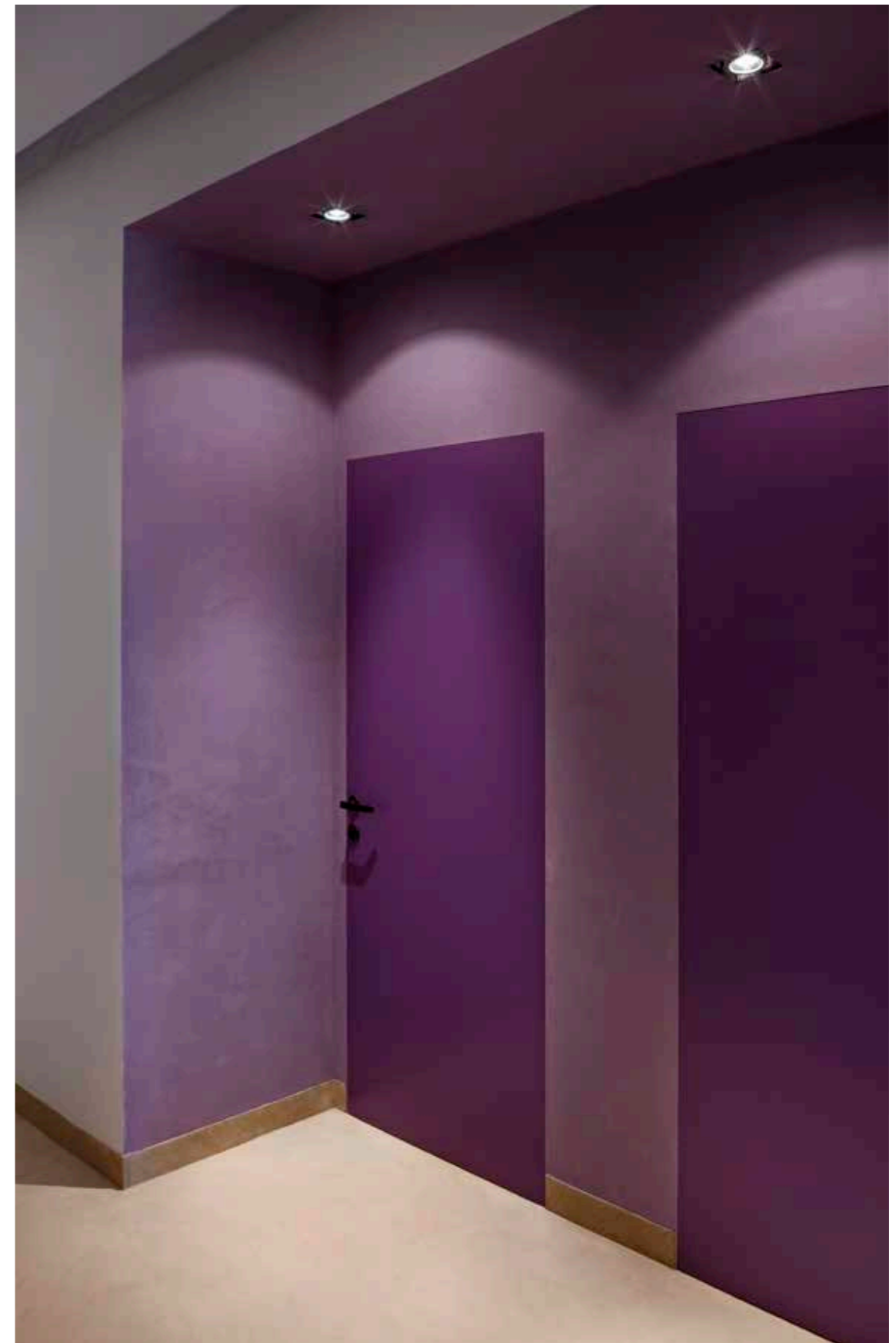

BATTERY

MICRO BATTERY

TRIM / NO TRIM SMALL
1L / 2L / 3L / 4L SQUARE



LED ARRAY
20W

TRIM / NO TRIM
SMALL
1L / 2L



QR-CBC 51
max 50W
- OR -
LED QR-CBC 51
7/10W

TRIM / NO TRIM
LARGE
1L / 2L



QR-111
max 100W
- OR -
LED QR-111

OPAL



LED ARRAY
9,2W

PAR 16
max 50W

QR-CBC 51
max 50W

FIXED



LED ARRAY
9,2W

ADJUSTABLE



PAR 16
max 50W
- OR -
LED PAR 16
4W

QR-CBC 51
max 50W
- OR -
LED QR-CBC 51
7/10W

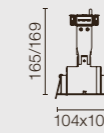
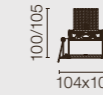
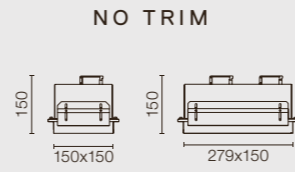
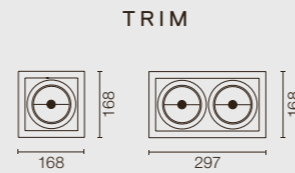
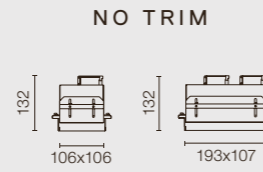
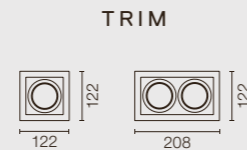
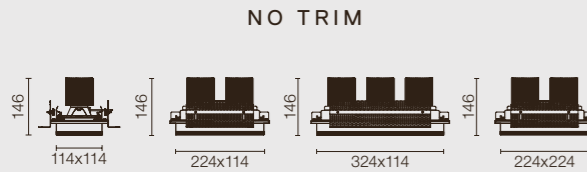
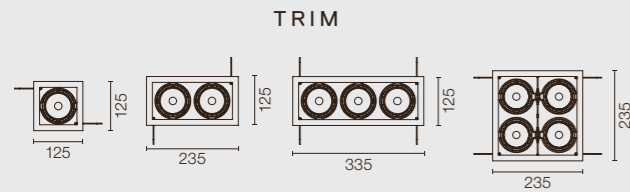

□ 20 Mattweiss
20 Matt White

■ 08 Quecksilber
08 Mercury

■ 14 Mattschwarz
14 Matt Black

Battery Trim /
No Trim



□ 20 Mattweiss
20 Matt White

■ 08 Quecksilber
08 Mercury

■ 14 Mattschwarz
14 Matt Black



Ist bis 40° in alle Richtungen hin schwenkbar.
Can be rotated 40° in any direction.

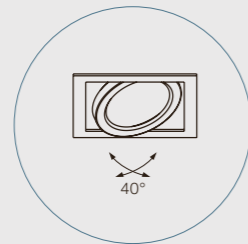

520

Die Modelle "adjustable" sind bis 40° in alle Richtungen hin schwenkbar.
Adjustable versions can be swivelled 40° in any direction.

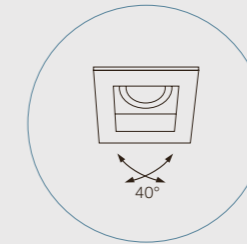

521

WAN

Familie mit Leuchten, deren Form durch die japanische Kultur inspiriert wurde: das Wort “wan” bedeutet Tasse in ihrer Funktion als “Lebensbehälter”. Zwei Ausführungen verfügbar: Die Strahlerausführung mit Sondersystem zur Lichtstrahlausrichtung und die Einbauausführung. Mit Halogen- oder Halogen-Metaldampflampen für die unterschiedlichsten Anwendungen im Wohn- und im Geschäftsbereich. Auch mit den neuen LED-Lampen erhältlich.

WAN

Family of lighting devices whose shape is inspired by the Japanese culture: in fact, “wan” means “cup” but in a figurative sense it is understood as a “life container”. Two versions: one spot, equipped with a special beam directional system and a second one for recessed systems. Available with halogen or metal halide lamps to adapt to different situations, either in residential or professional sectors. Also available with the new LED lamp.



DESIGNED BY JOHANNA GRAWUNDER



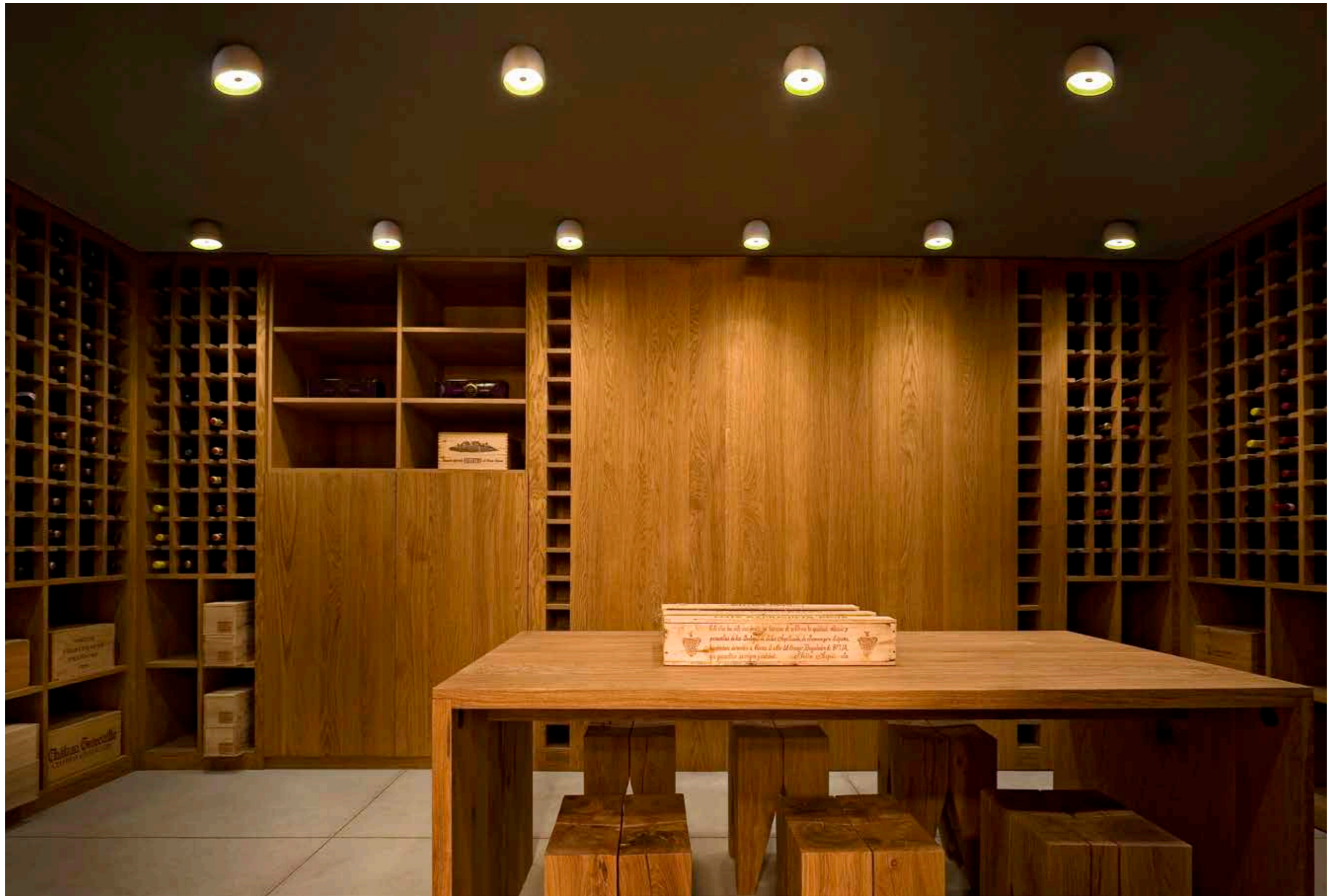

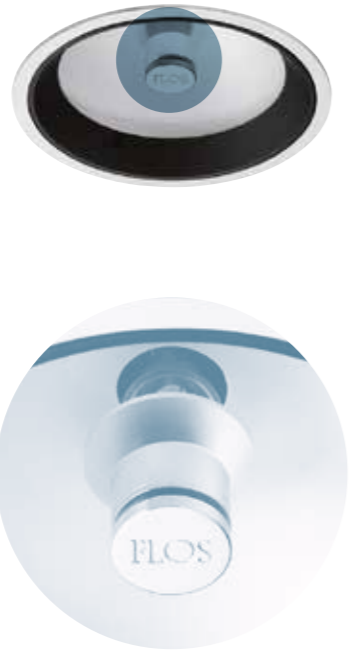

Der Optikkörper der Leuchte verfügt über ein kegelförmiges Element, das die Blendung verringert, wenn man in die Lichtquelle direkt schaut.

The optical body of the luminaire is provided with a conical element which reduces the glaring effect, in the case that someone looks directly at the light source.



Leuchtenbau und -ausbau ohne Hilfe von speziellen Werkzeugen. Der Lampenaustausch wird durch einen Bajonettverschluss durchgeführt.

Luminaire installation and removal without using any special tool. All operations needed for replacing a bulb are carried out with a bayonet hinge.



System zur Ausrichtung des Lichtstrahls im Hauptkörper der Leuchte integriert.

The light beam adjustment system is integrated in the main body of the luminaire.







WAN SPOT



SAL GORDA RESTURANT - SPAIN

WAN DOWNLIGHT



PRIVATE HOUSE - U.K.

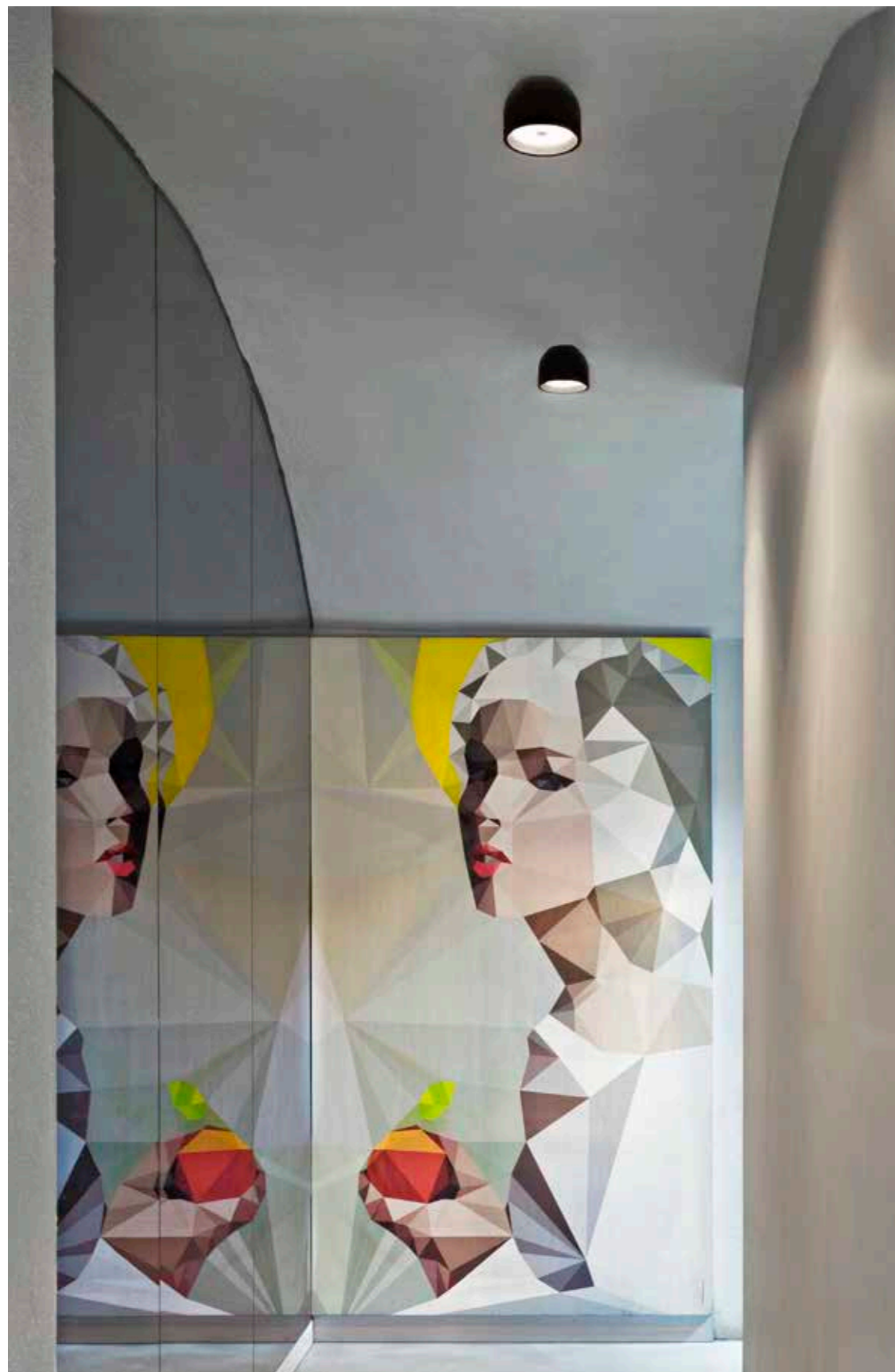

| | SPOT | | DOWNLIGHT | |
|---------------|----------------------|---|------------------------|---------------------|
| | | | | |
| | LED ARRAY 9,2W | QT-14 max 40W | LED ARRAY 9,2W | QT-12 max 50W |
| | | | | |
| | | | | |
| | 30 Weiss 30 White | 05 Hochglänzendes Aluminium 05 Polished Aluminium | 14 Schwarz 14 Black | GN Grün GN Green |
| Wan Spot | | | | |
| Wan Downlight | | | | |

Drehbar um 360° und schwenkbar 60°.
Can be rotated 360° and swivelled 60°.

Wan Spot

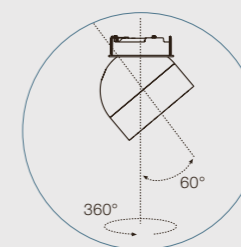



DOWNLIGHTS

Flos ist mit den verschiedenen Downlight-Serien in der Lage, den meisten Bedürfnissen professioneller Beleuchtung in Dienstleistungsgebäuden und Ladenlokalen sowie auch für zu Hause gerecht zu werden. Ein breites Angebot von verschiedenen Größen, Lampenarten und Leistungsstärken mit hohen Leuchtwirkungsgraden und verschiedenen Leuchtschirmen erfüllt jeglichen, vom Designer beschriebenen Anspruch.

DOWNLIGHTS

With its different downlight series, Flos is capable of satisfying the majority of professional lighting needs in services buildings and commercial premises as well as in the home, thanks to its wide range of lights that includes several sizes, different types of lamps and power ratings. It has high luminous performance and offers the possibility of protective shields that are able to satisfy any requirements that designers may have.



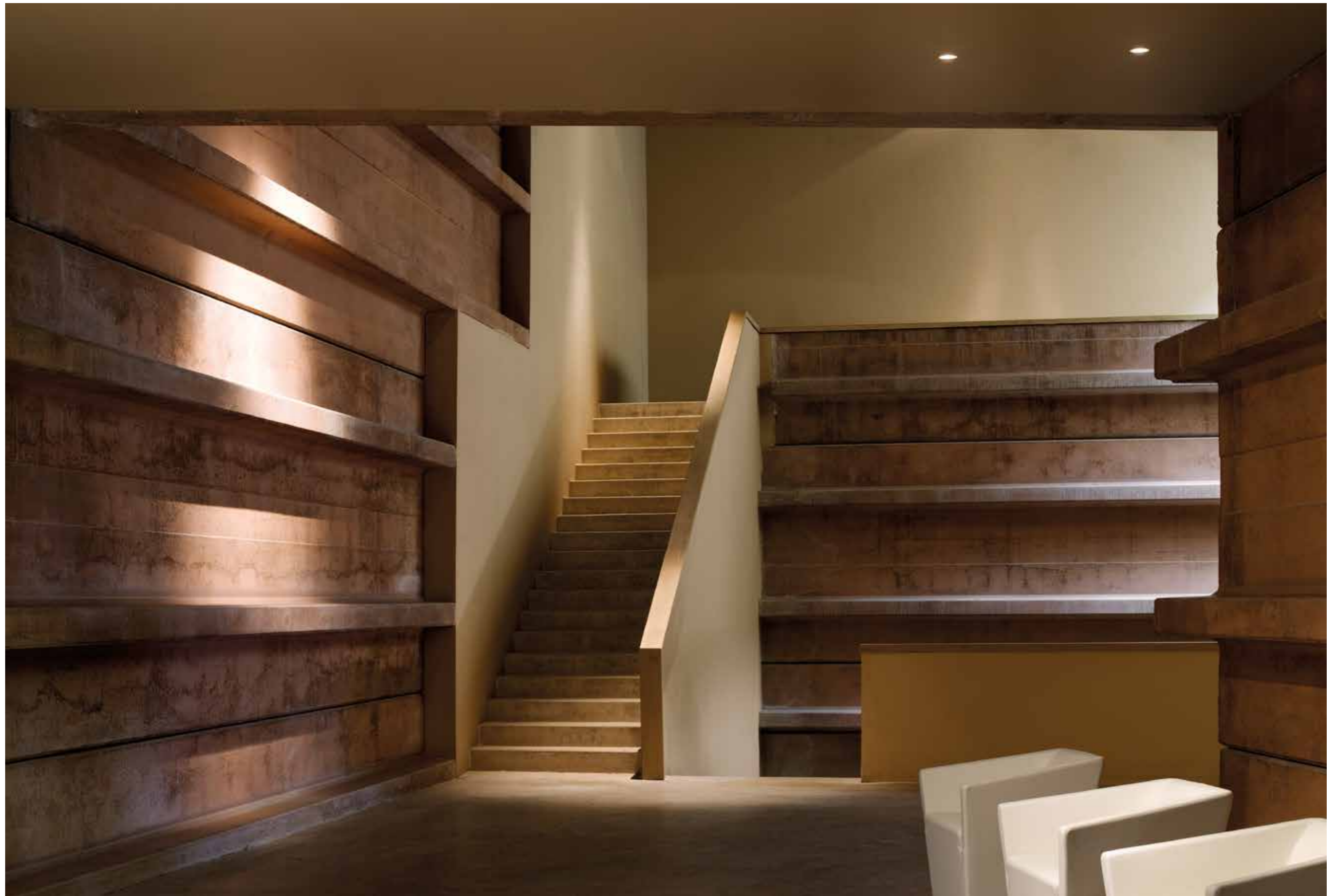



Erhältlich in fester und in Schwenkausführung mit 360°-Drehung und 30°-Ausrichtung.

Available in fixed version and in tilting version rotated at 360° and directional at 30°.

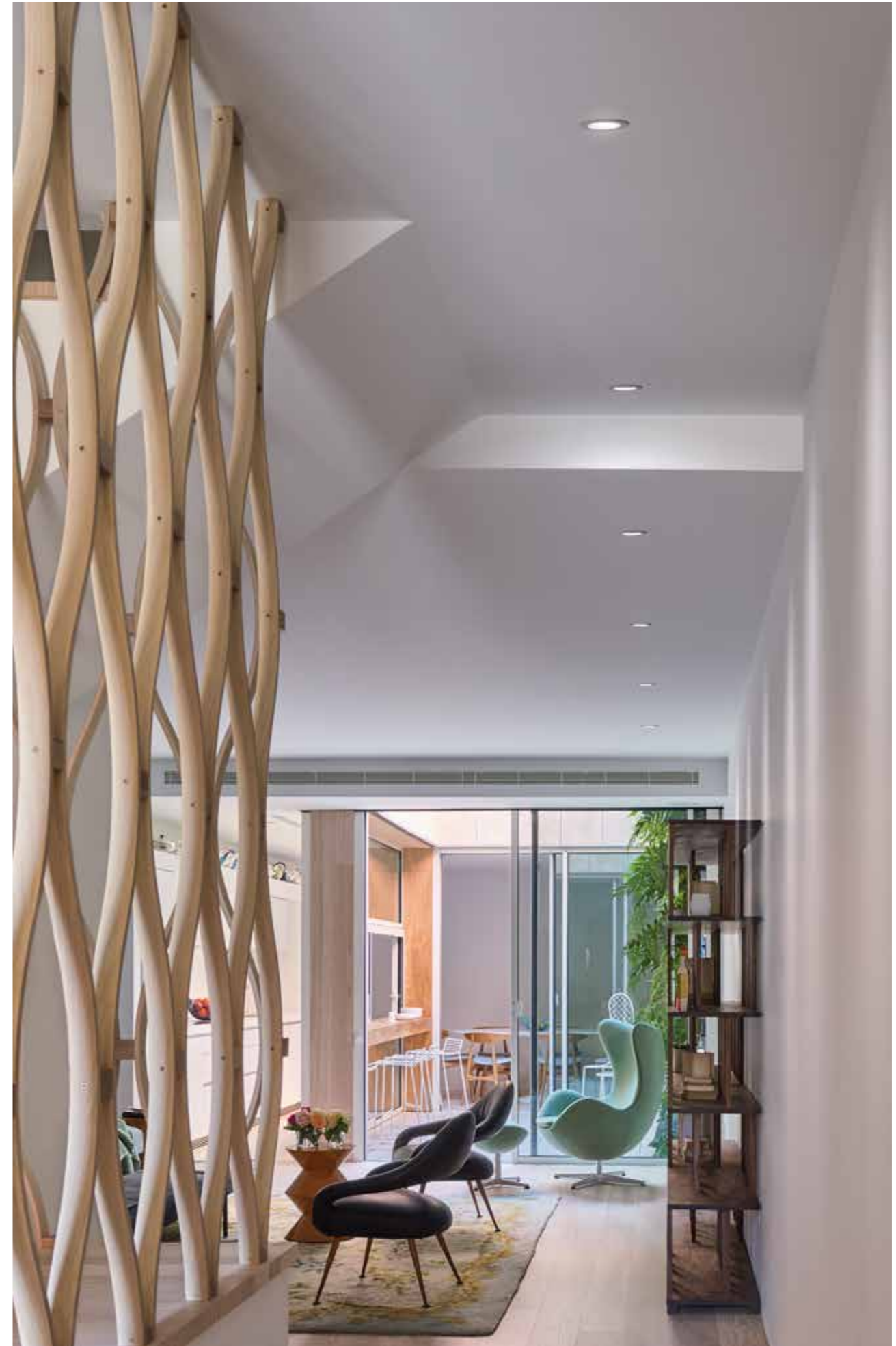

LIGHT SOLDIER



MARGUES DE LA ENSENADA HOTEL - SPAIN

LIGHT SOLDIER

FIXED Ø75

ADJUSTABLE Ø90



LED ARRAY
9,2W

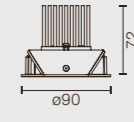
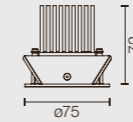

Spot



Medium



Wide Flood

30 Weiss
30 White



02 Grau
02 Grey



14 Schwarz
14 Black



Drehbar um 360° und schwenkbar 30°.
Can be rotated 360° and swivelled 30°.

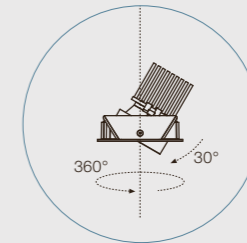

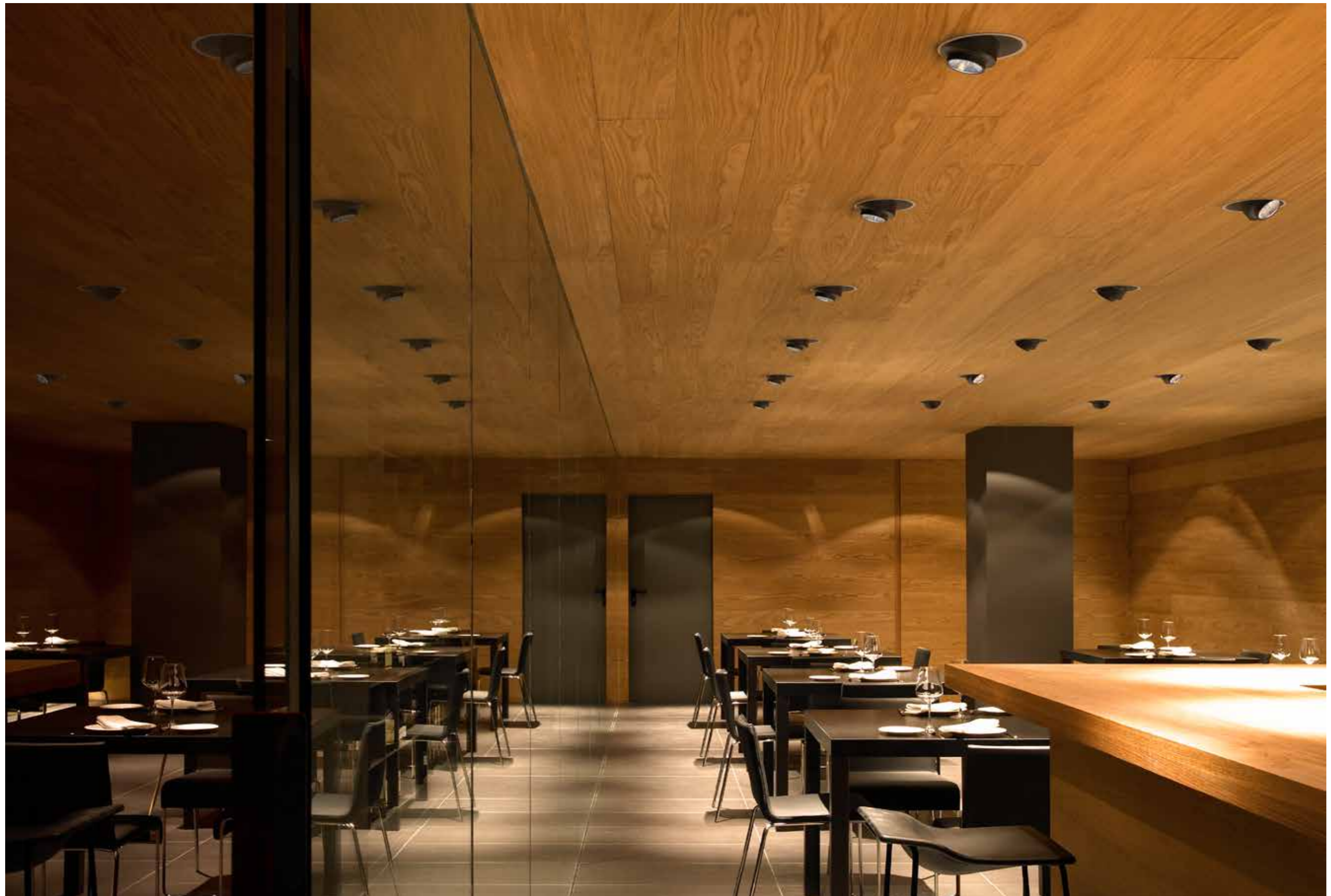

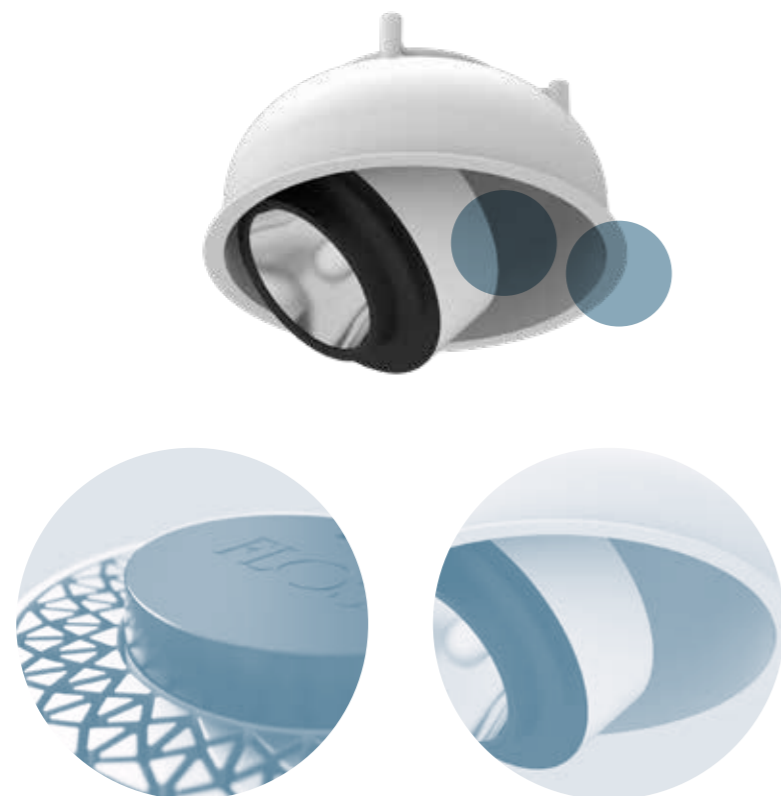

Das ausgeklügelte Design des Projektors reicht bis zum innovativen exklusiven Radiator.

The stylish design of the projector extends to the exclusive innovative radiator.

Einbaukuppel-Design für den Einbau in Zwischendecken.

Dome design that can be recessed for full integration in a false ceiling.

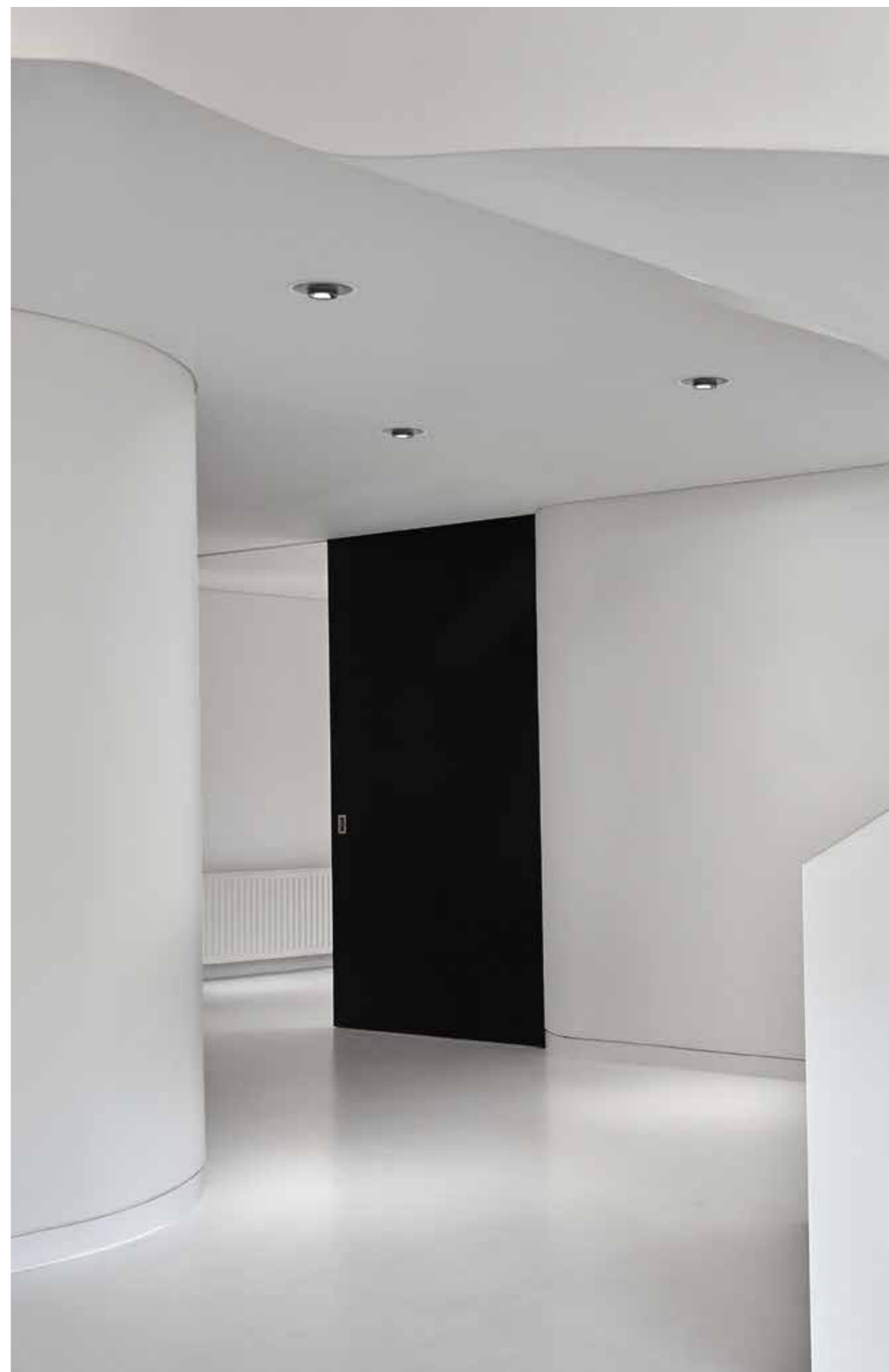



POWER LED
10W

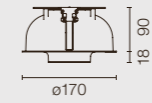

Spot

Medium

□ 40 Weiss
40 White

■ 05 Chrom
05 Chrome

■ 14 Schwarz
14 Black



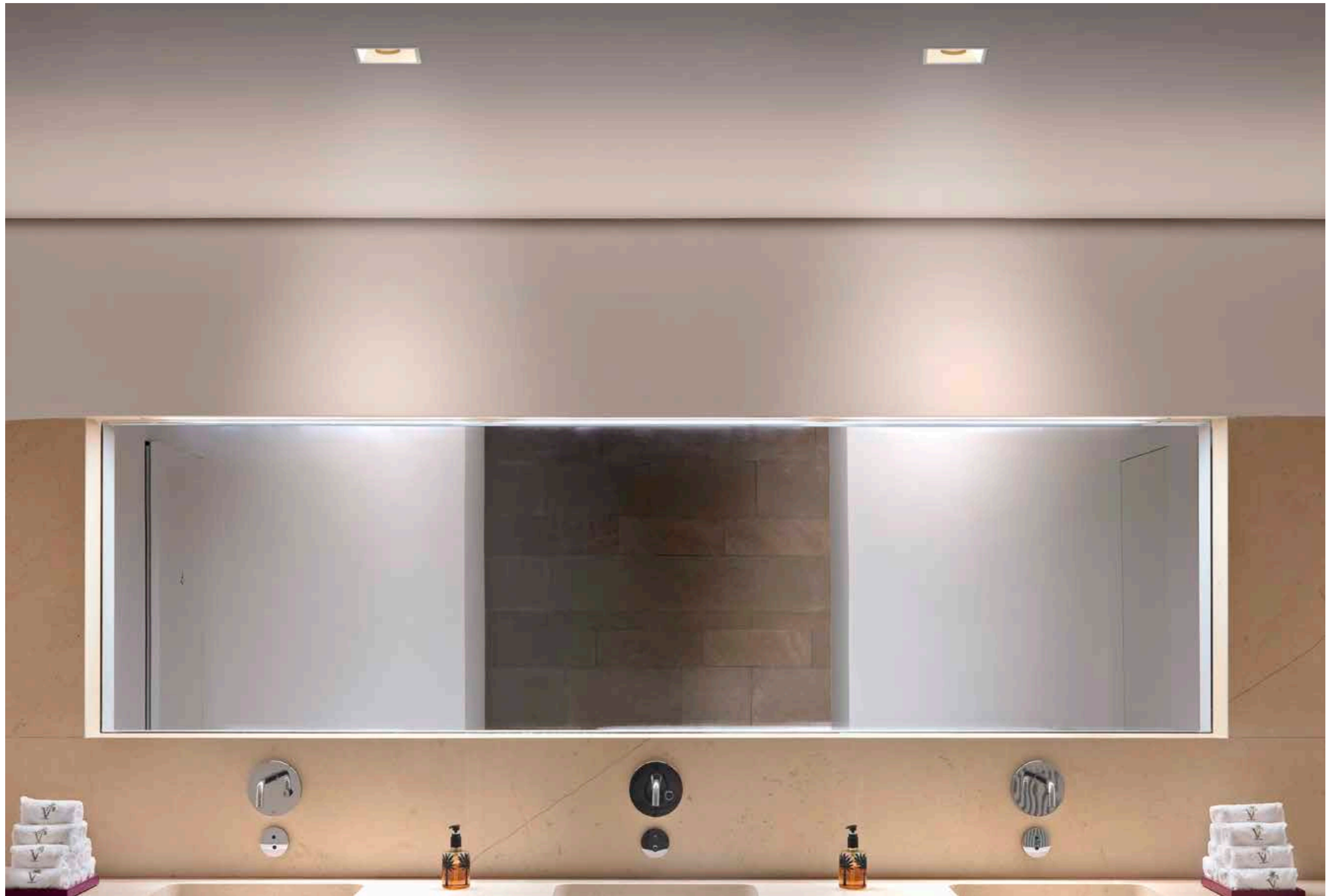



Lichtquelle in zurückgesetzter Position für hohen Sehkomfort.

Delayed light source that offers great visual comfort.

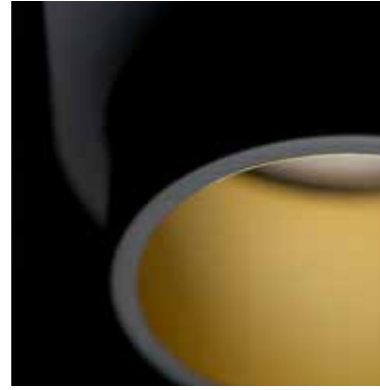

Abschirmzylinder in drei Verarbeitungen erhältlich: Schwarz, Gold oder Silber, die untereinander kombinierbar sind.

Cut-off pipe available in three finishes: black, gold or silver, that are interchangeable.

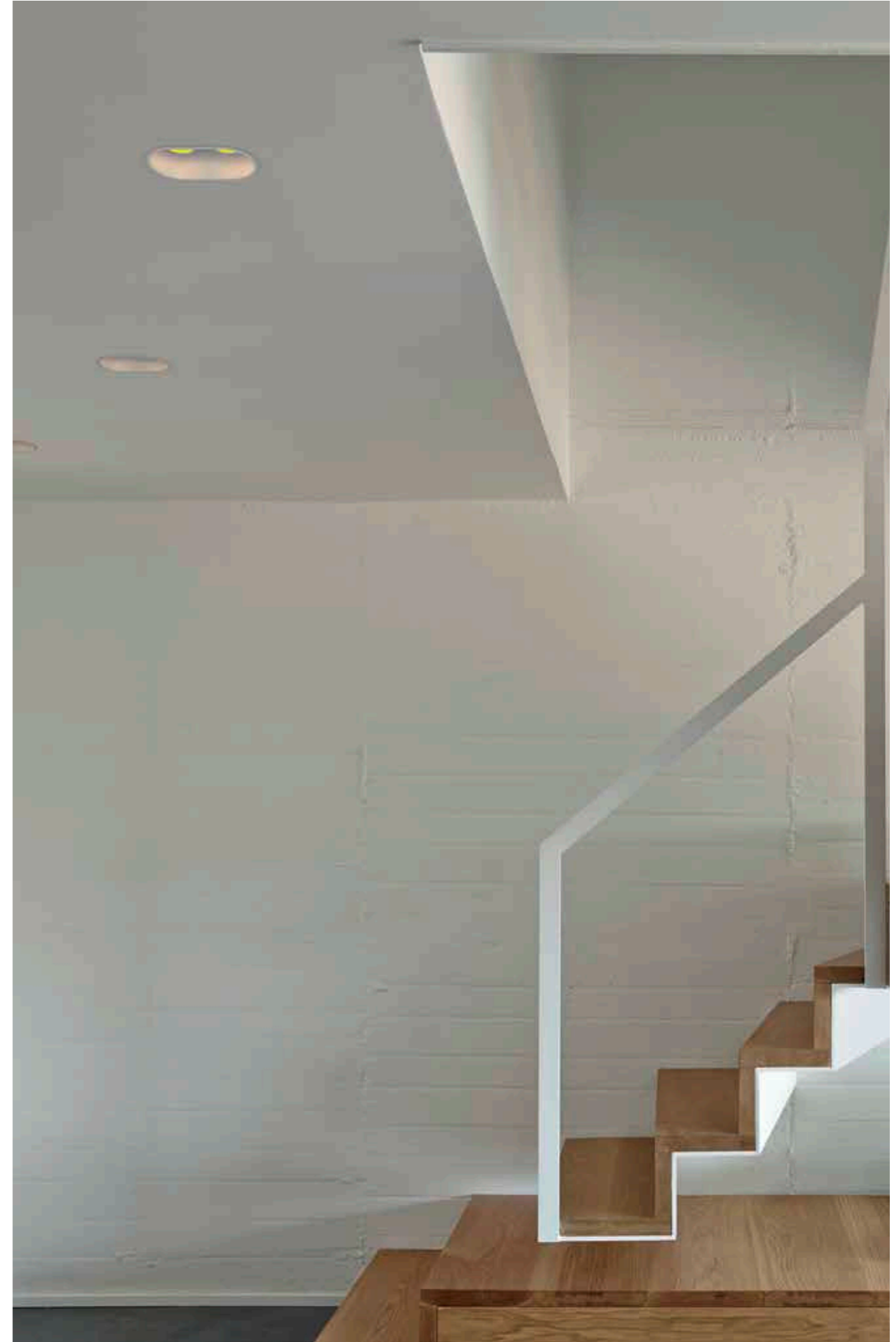



DECOFIX
ROUND 1L

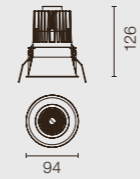

DECOFIX
ROUND 2L

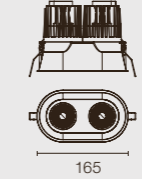

DECOFIX
SQUARE 1L



DECOFIX
SQUARE 2L

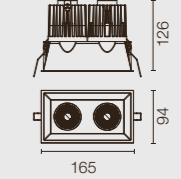

LED ARRAY
9,2W

30 Weiss
30 White

14 Schwarz
14 Black



Abschirmkegel-Farben
Screening Cylinder Colours

Silber
Silver

Gold
Gold

Schwarz
Black







Der Strahler enthält einen Mechanismus, der die Schwenkung des Lichtstrahls blockiert, um einen eventuellen Strahlversatz bei der Wartung zu vermeiden.

The spot includes a mechanism that locks the light adjustment system in order to prevent it shifting during maintenance.



Das kardanische Ausrichtsystem des Einbaustrahlers Compass Ø162, das an einen "Kompass" erinnert, erlaubt einen Schwenkbereich von 40° in alle Richtungen.

Adjustable angle Compass Ø162 fixtures incorporate a revolutionary 'compass-type' tilt system that allows the fixture to be inclined up to 40° from the vertical in any direction.

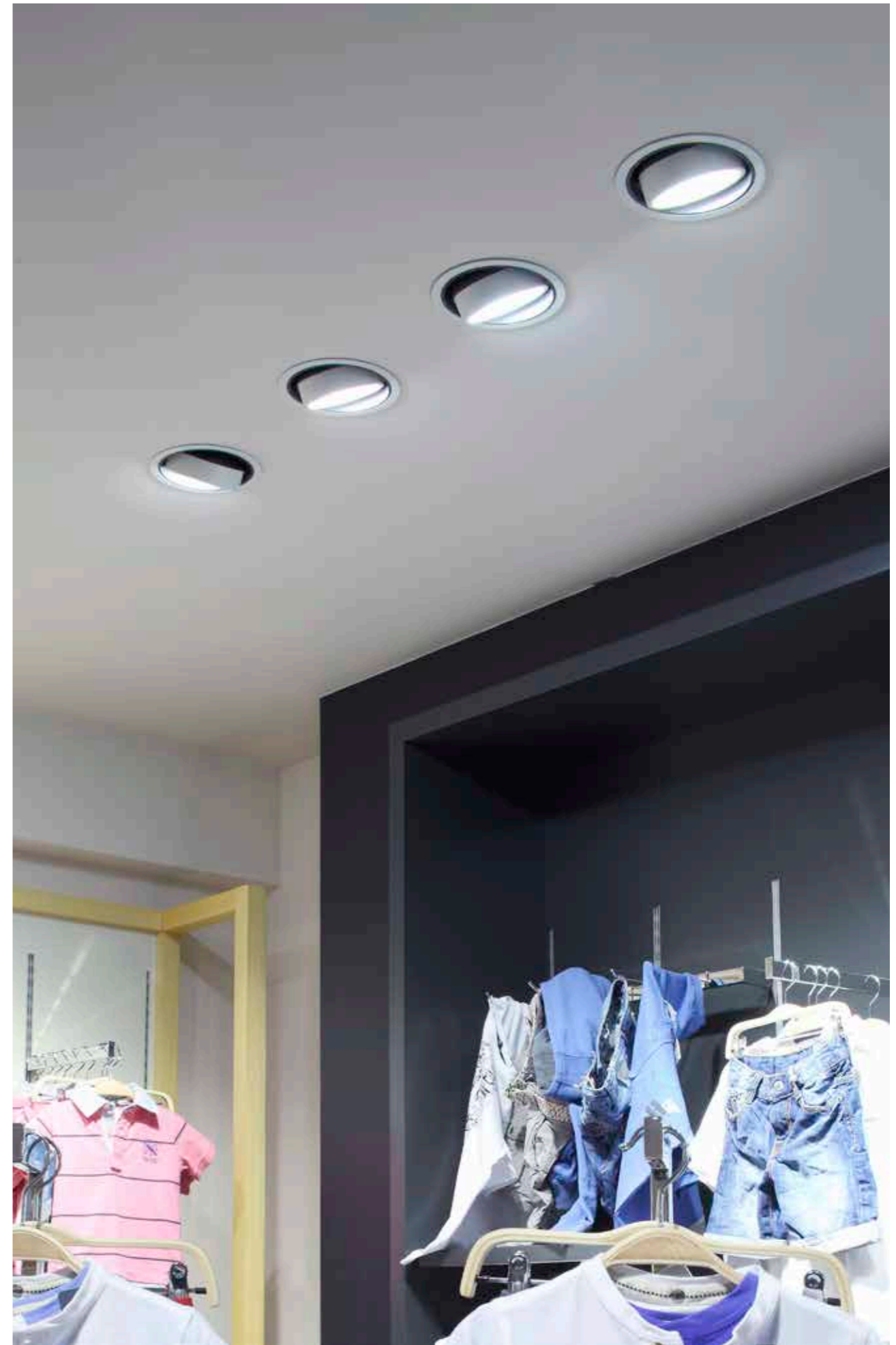

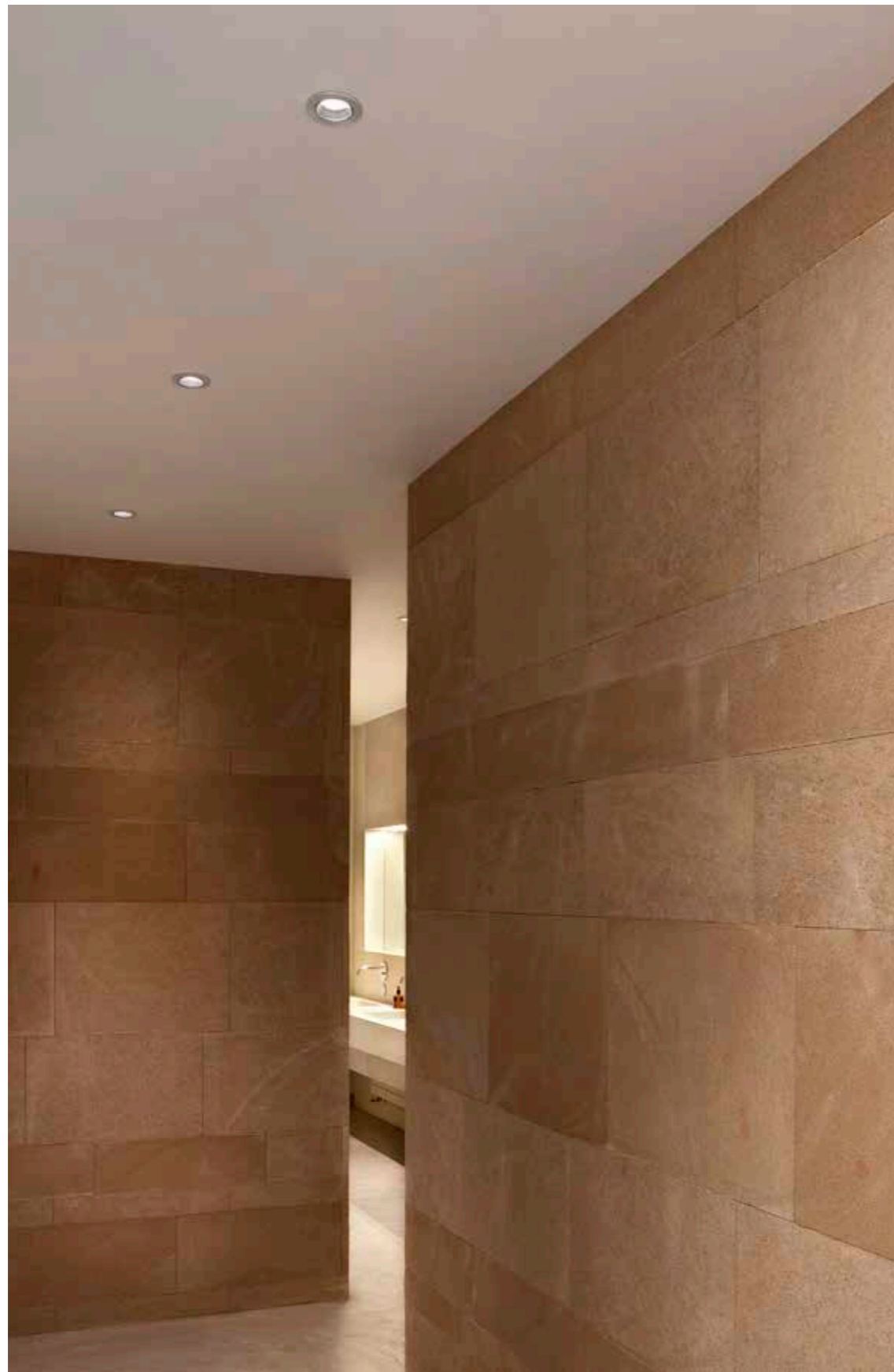

| ADJUSTABLE Ø90 | OPAL Ø90 | FIXED Ø90 | IP65 Ø95 | ADJUSTABLE Ø162 |
|---|---|--|--|--|
|  |  |  |  |  |
| <p>* PAR 16 max 50W</p> <p>** QR-CBC 51 max 50W - OR - LED QR-CBC 51 7/10W</p> | <p>QT-12 max 50W</p> | <p>QR-CBC 51 max 50W - OR - LED QR-CBC 51 7/10W</p> | <p>QR-CBC 51 max 50W - OR - LED QR-CBC 51 7W</p> | <p>QR-111 max 100W - OR - LED QR-111</p> |
| <p>* </p> <p>** </p> <p>** </p> | <p></p> <p></p> | <p></p> | <p></p> | <p></p> |

□ 30 Mattweiss
30 Matt White

■ 02 Grau
02 Grey

■ 14 Mattschwarz
14 Matt Black



Compass Ø90

Compass Ø162

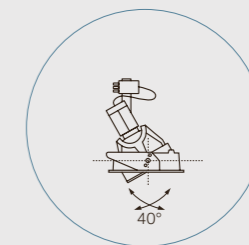
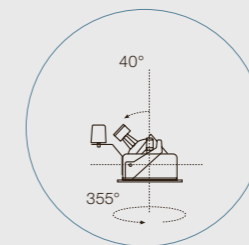



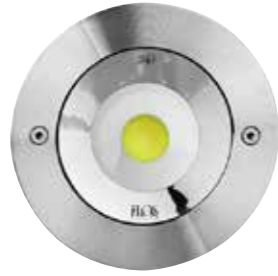

Einbauleuchte für den Außenbereich für LED mit Phosphorschicht 8,3W, Farbtemperatur 3000K und Lichtstrom 720 lm. Farbwiedergabe 80.

Recessed luminaire for outdoor installation with 8,3W remote phosphor LED, colour temperature of 3000K and luminous flux of 720 lm. Colour rendering 80.



Leuchte bestehend aus 6 Power LEDs mit Konstantstrom 4,2W. Farbtemperatur 3000K. Farbwiedergabe 80. Optik mit verschiedenen Lichtstrahlöffnungswinkeln: 10°, 21° und 37°.

Luminaire consisting of 6 Power LEDs with 4,2W constant current. Colour temperature of 3000K. Colour rendering 80. The optics are available with different light beam angles: 10°, 21° and 37°.



Die neue Ausführung als Signalleuchte enthält eine Linse zur Verteilung des Lichtstroms mit 180° Winkel, Power LED 1,2W.

The new signal version of the luminaire includes a light distribution lens with 180° angle and 1,2W Power LEDs.



Die LED-Ausführung mit Phosphorschicht enthält einen elektronischen Trimmer im Innenbereich eines externen luftdichten Elements mit Schutzgrad IP67.

The remote phosphor LED version of the luminaire includes an electronic driver placed inside an airtight housing with protection class IP67.

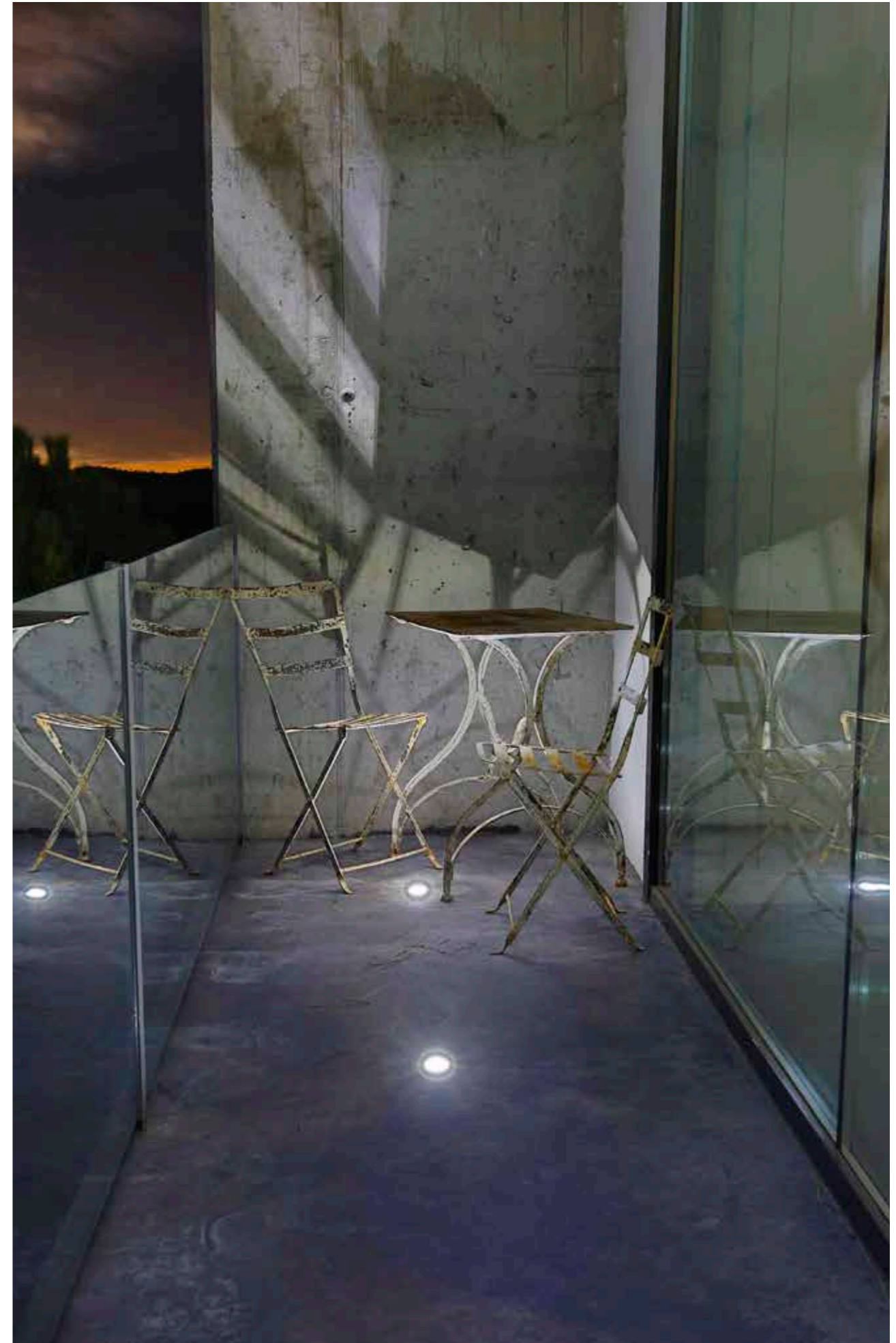



NEUTRON I NO TRIM



POWER LED
4,2W

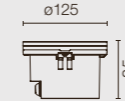

NEUTRON I



PHOSPHOR LED
8,2W

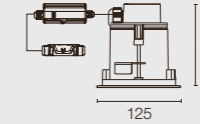

POWER LED
1,5W
7W

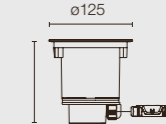

Spot



Medium



Flood

Neutron I No Trim

■ 14 Schwarz
14 Black



Neutron I

■ 04 Mattschwarz
04 Matt Black



■ 55 Inoxfarben
55 Stainless Steel



■ PB Inoxfarben Dunkelkupfer
PB Stainless Steel Dark Copper



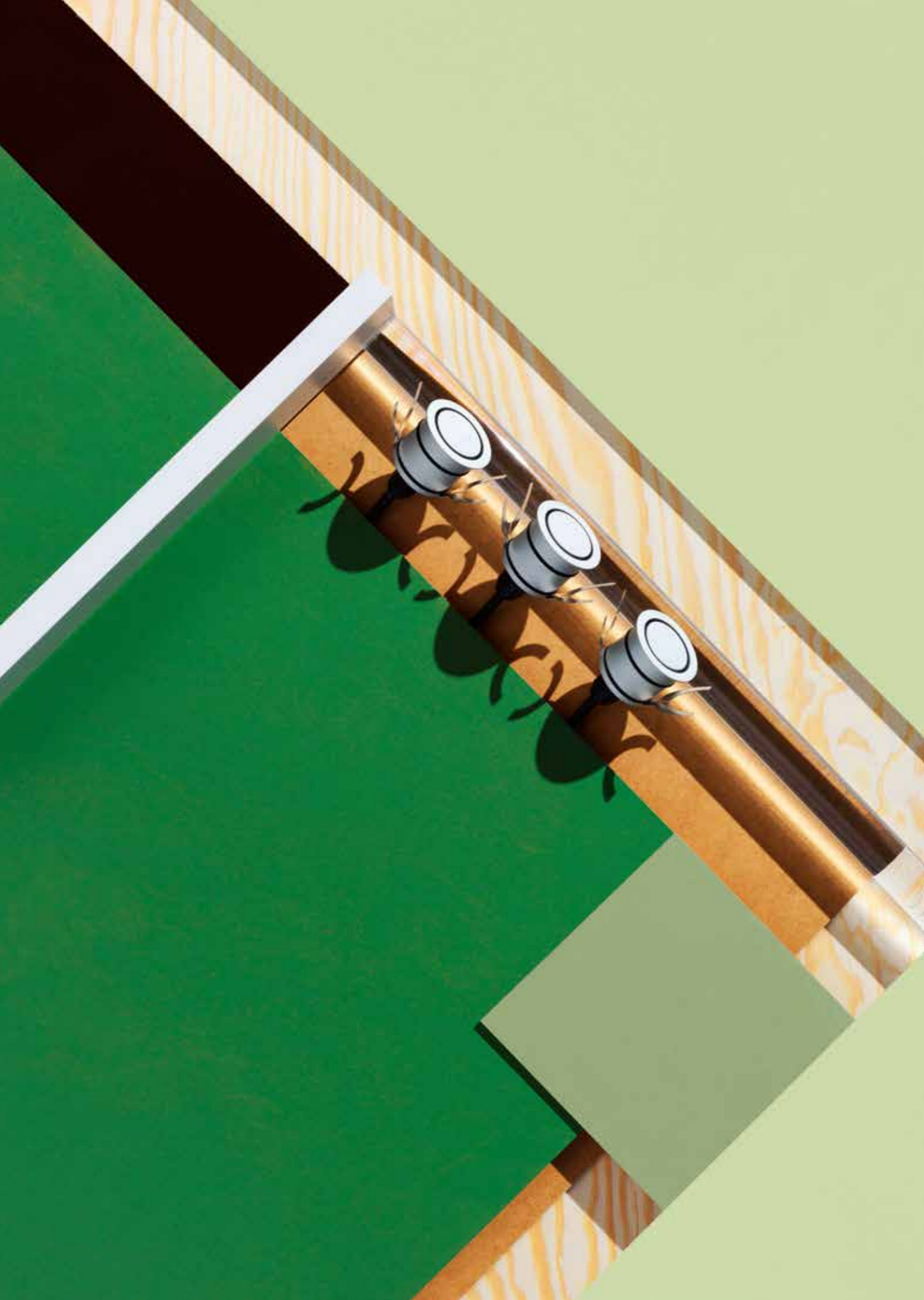

G - O

Einbauleuchte mit Schutzart IP65 für Innen- und Außenräume. Ausgestattet mit LED jüngster Generation ist G-O speziell für die Orientierungsbeleuchtung von Durchgängen oder Treppen konzipiert worden. Erhältlich in Weiß, Aluminium, Inox, Bronze und Schwarz. Dank der eingebauten farbigen Diffusoren kann das optische System warmes weißes oder gelbes Licht abgeben.

G-O

Recessed luminaire with IP65 protection degree for indoors/outdoors use. Equipped with latest generation LED, G-O is especially designed as bollard lighting for pathways or steps. It is available in white, aluminium, stainless steel, bronze and black finishes. The optical equipment can transmit warm white or amber light thanks to the coloured diffusers on the inside.



DESIGNED BY JORGE HERRERA





Speziell entworfen für die Orientierungsbeleuchtung von Architekturräumen wie Treppen, Wegen etc. Schutzart IP65 für sichere Verwendung in Innen- und Außenräumen.

Especially designed for signage of architectonic spaces such as stairs, pathways, etc. IP65 protection degree guaranteeing correct outdoor/indoor use.

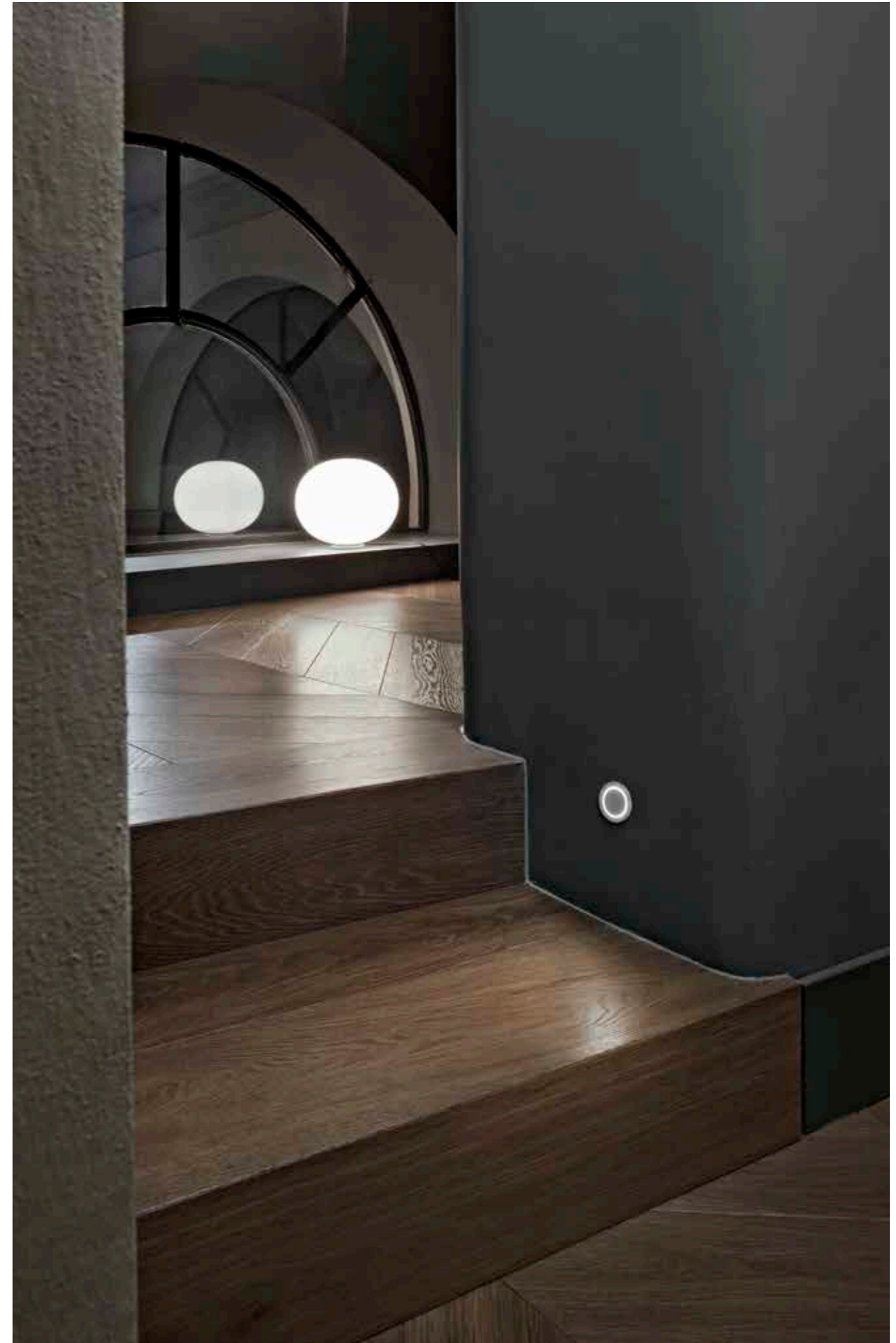

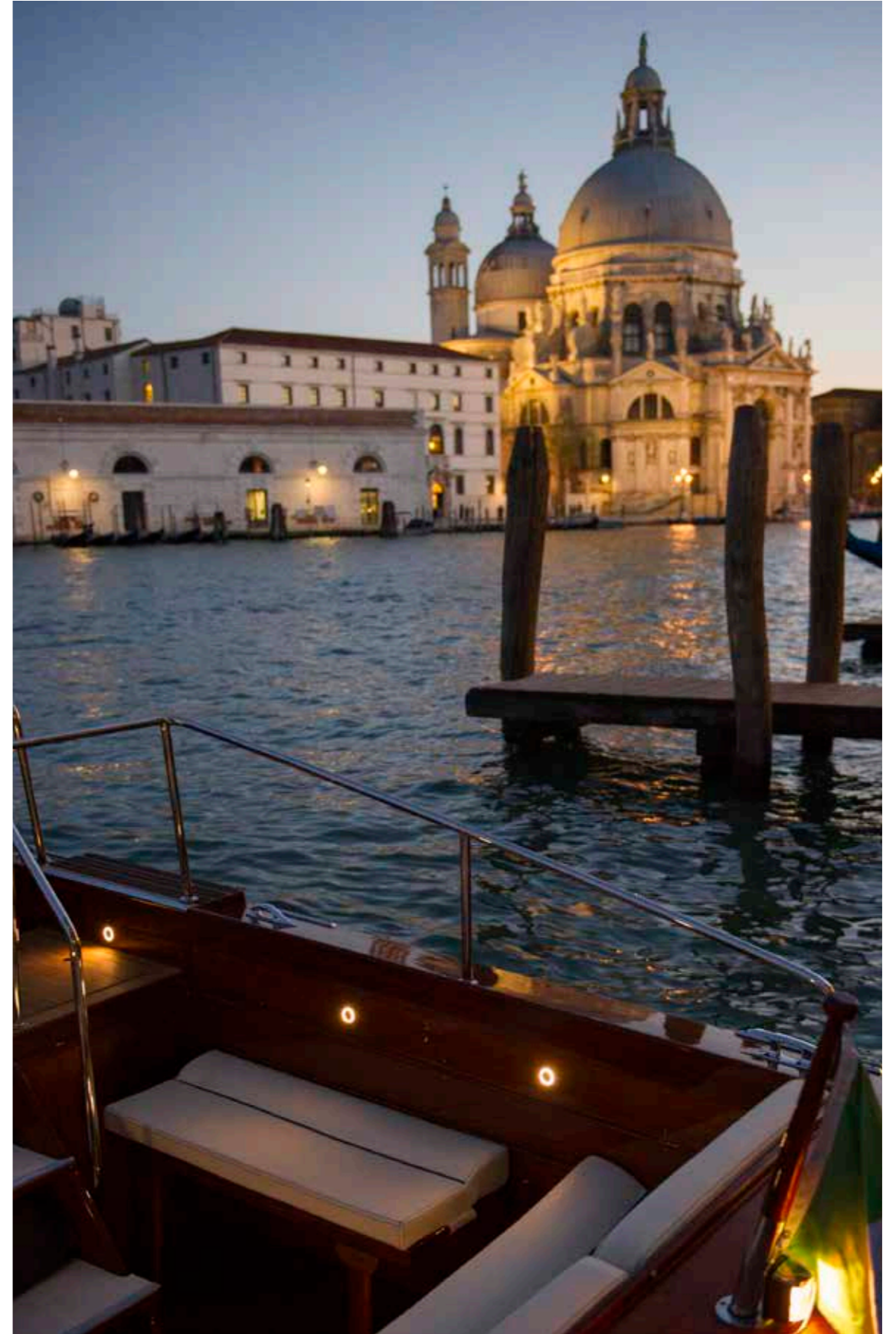
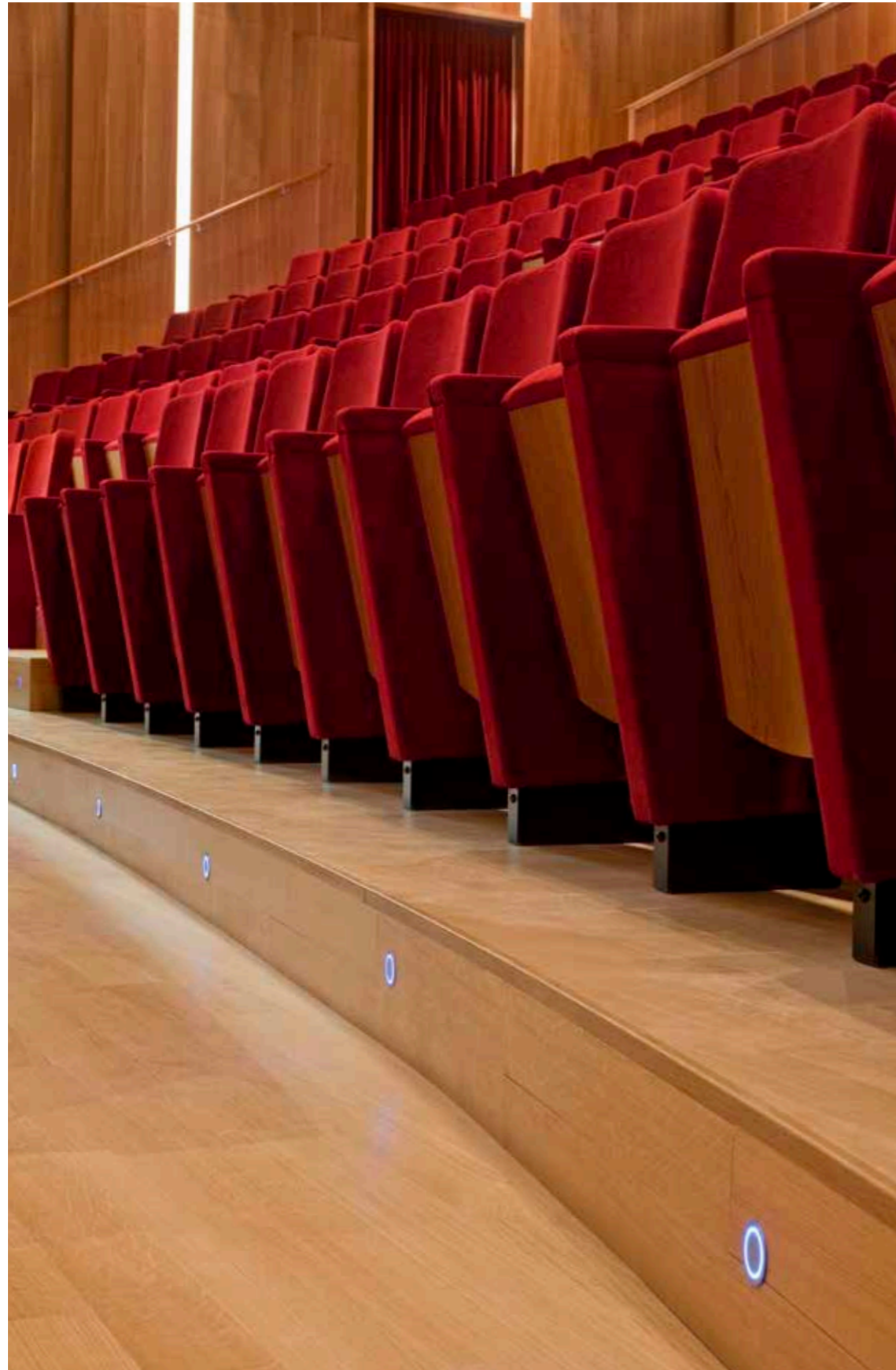



TOP LED
1,2W



□ 30 Mattweiss
30 White

▨ 29 Eloxiertes Aluminium
29 Anodized Aluminium

■ 55 Inoxfarben Stainless Steel
55 Stainless Steel



■ BZ Bronze
BZ Bronze

■ AN Eloxiertes Schwarz
AN Anodized Black



Lichtfarben
Light Colours

□ Weisses Licht
White Light

■ Amber Licht
Amber Light



THEBLOCKOFLIGHT

Einbau-Hinweisleuchte. Perfekt für Innen- und Außenräume dank Schutzart IP65. TheBlockofLight verfügt über ein Power LED jüngster Generation und einen opalen Diffusor für optimale Lichtverteilung.

THEBLOCK OFLIGHT

Recessed signage luminaire. Perfect for indoors/outdoors thanks to its IP65 protection degree. TheBlockofLight has a latest generation Power LED and an opal diffuser for optimal light distribution.



DESIGNED BY KNUD HOLSCHER

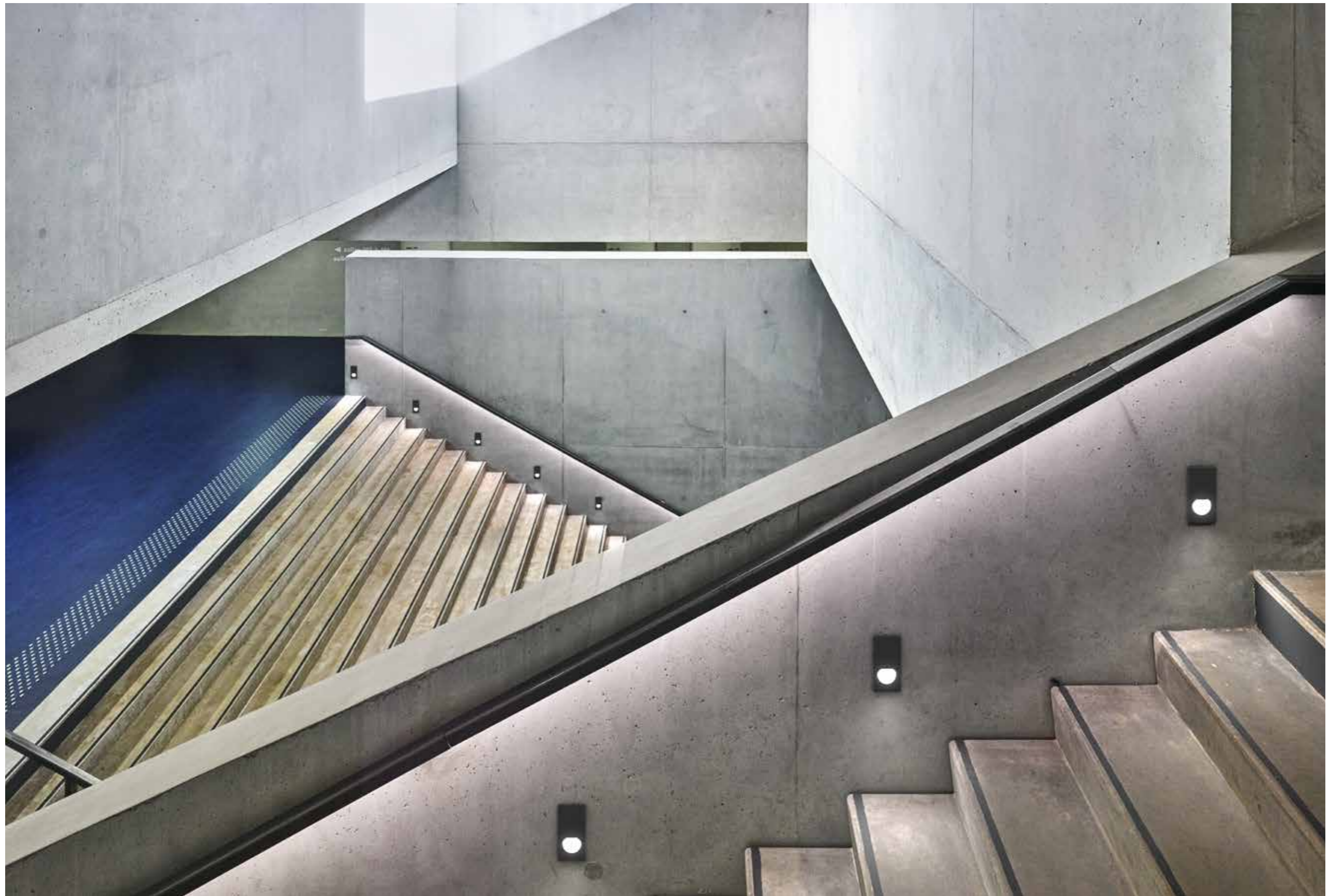



Einbauleuchte mit LED-Lichtquelle der jüngsten Generation. Schutzart IP65 für korrekte Funktionsweise in Außenräumen.

Recessed luminaire with latest generation LED light source. IP65 protection degree guaranteeing correct outdoor use.



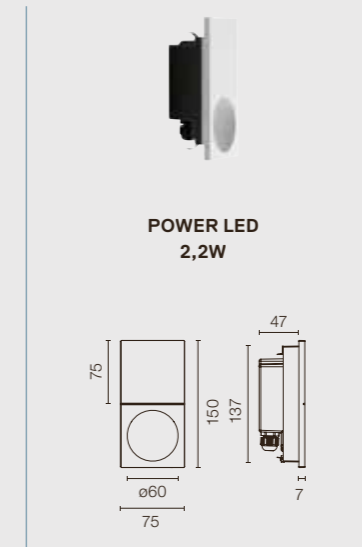
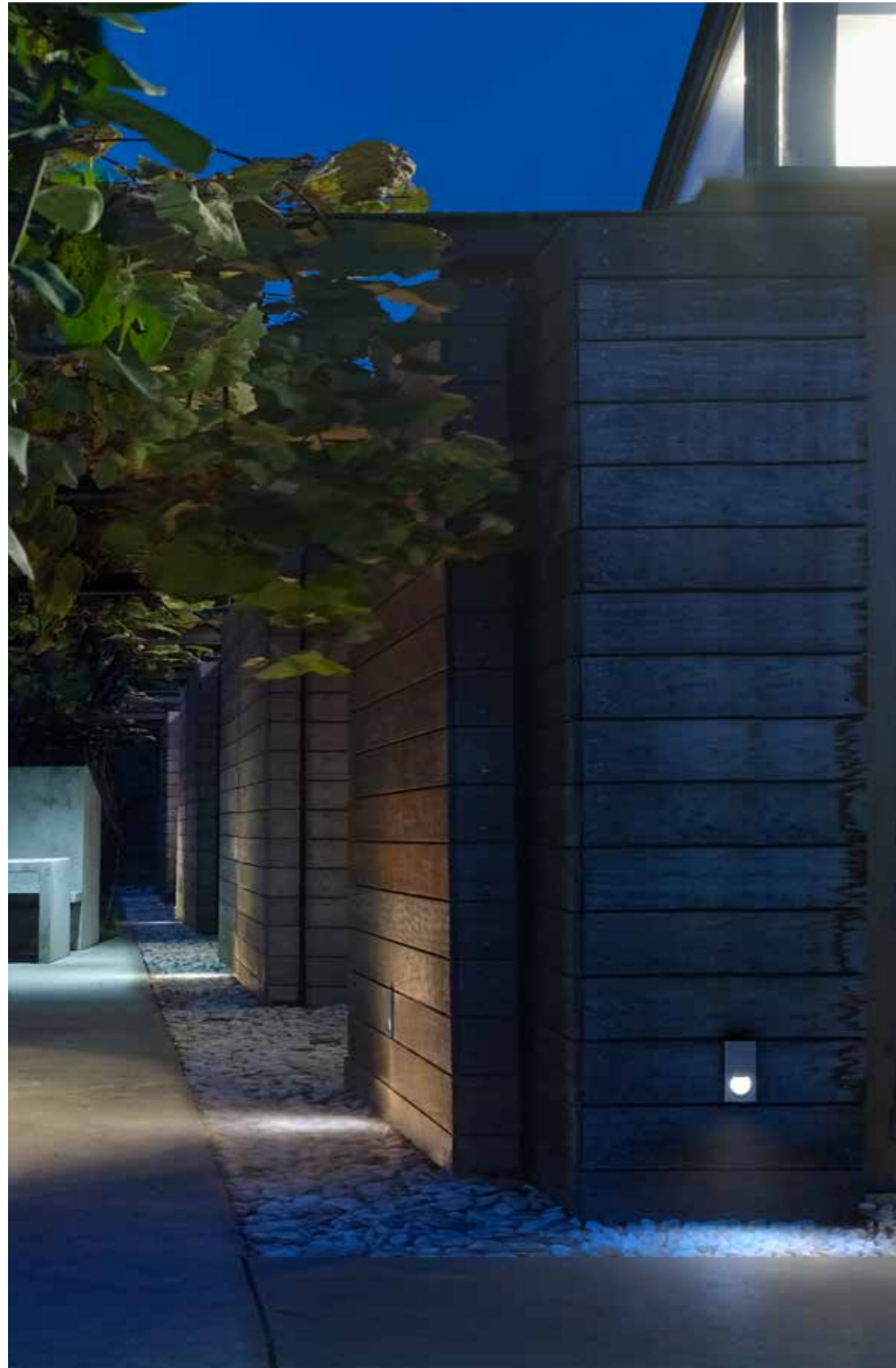

01 Mattweiss
01 Matt White

72 Grau
72 Grey

04 Mattschwarz
04 Matt Black

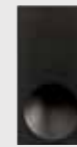

GIANO

Die Giano Einbauleuchten haben eine Schutzart von IP65 und sind mit LED ausgestattet. Sie strahlen Licht unterhalb eines Winkels von ungefähr 15° unterhalb der Horizontalen aus. Auf diese Weise sind sie die idealen Fluter für eine selektive Beleuchtung von Gangzonen und Fluren in Innenbereichen aber auch in Außenbereichen wie Terrassen, Innenhöfen, Zugangswegen zu Garagen oder Wohnanlagen.

GIANO

The Giano recessed luminaires, with IP65 protection degree, are equipped with LED light sources and they project light at an angle of less than 15° , approximately, below the horizontal plane. In this way, they act as floor washers, ideal for lighting corridors in both indoor and outdoor facilities, terraces, driveways or housing estates.



DESIGNED BY RODOLFO DORDONI





Diese Anbauleuchte enthält in ihrem Innenbereich einen Treiber zur Kontrolle der perfekten LED-Funktionsfähigkeit in einer extrem kompakten Form.

This surface luminaire incorporates a driver which controls the perfect LED functioning and offers an extremely compact design.

Einbaubehälter für Betonwände, das aus Thermoplastkunststoff mit Mineralinhalt mit hoher mechanischer Festigkeit besteht und anwendungsfreundlich ist.

Accessory for recessed mounting on cement walls made of mineral filled thermoplastic for high mechanical resistance and easy installation.



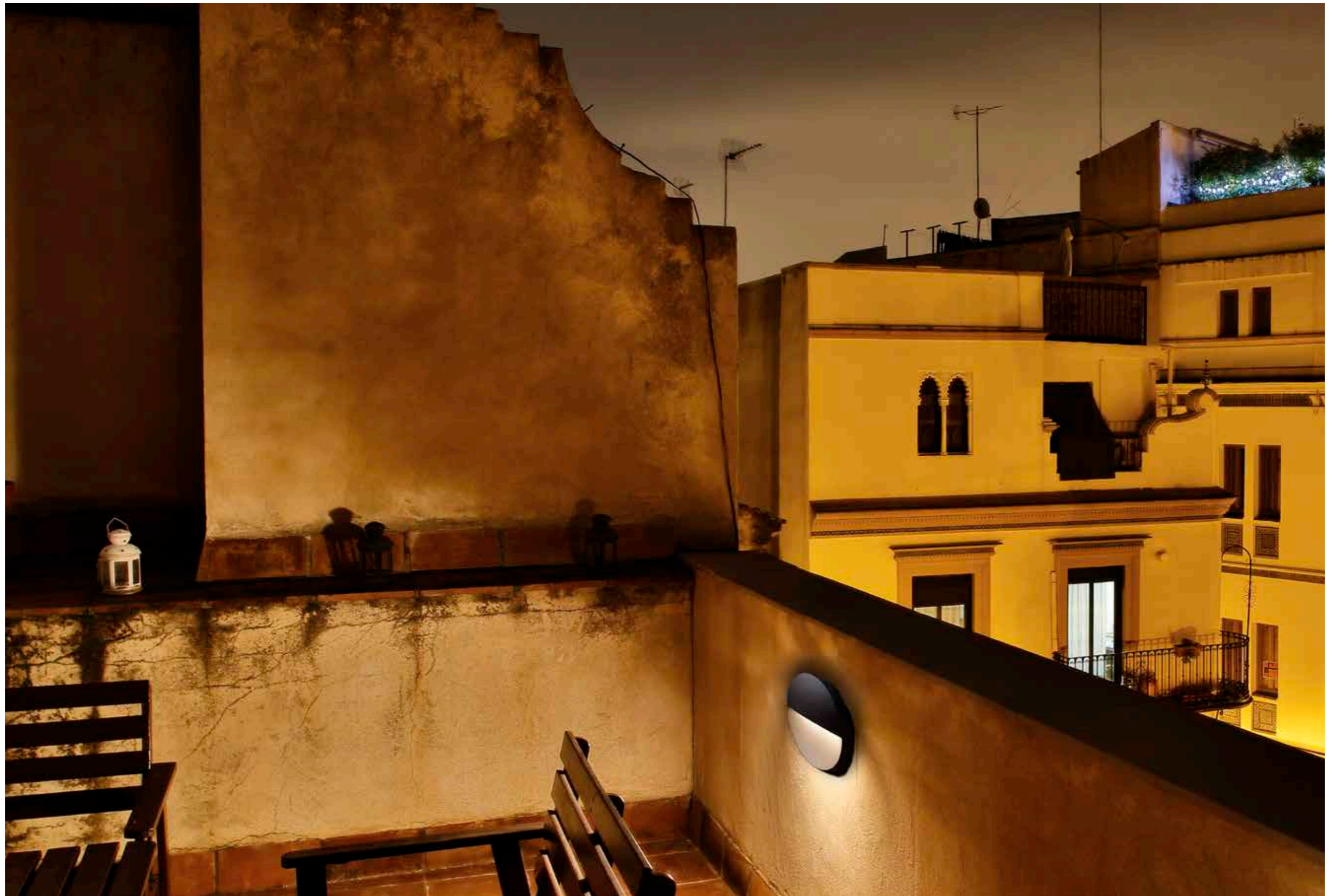



GIANO
Ø100

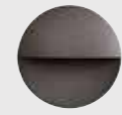

POWER LED
1W

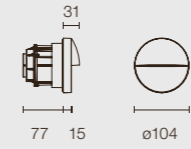

GIANO
Ø220



POWER LED
6W

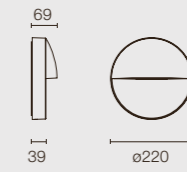

□ 01 Mattweiss
01 Matt White

■ 72 Grau
72 Grey

■ 04 Mattschwarz
04 Matt Black

■ MM Dunkelbraun
MM Dark Brown

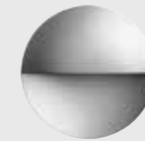

BOX

Familie von Wandeinbauleuchten mit asymmetrischem Licht für eine optimale Beleuchtung bei jeder Anwendung. Die jüngsten Ausführungen verfügen über die neueste LED-Technologie. Das neue Einbauzubehör ermöglicht einen perfekten Wandeinsatz.

BOX

Family of devices for recessed wall mounting with asymmetric light designed to guarantee a high performance in every situation. The new versions have been equipped with latest generation LED lamps. A new recessing device is available for perfect surface-mounting.



DESIGNED BY PIERO LISSONI

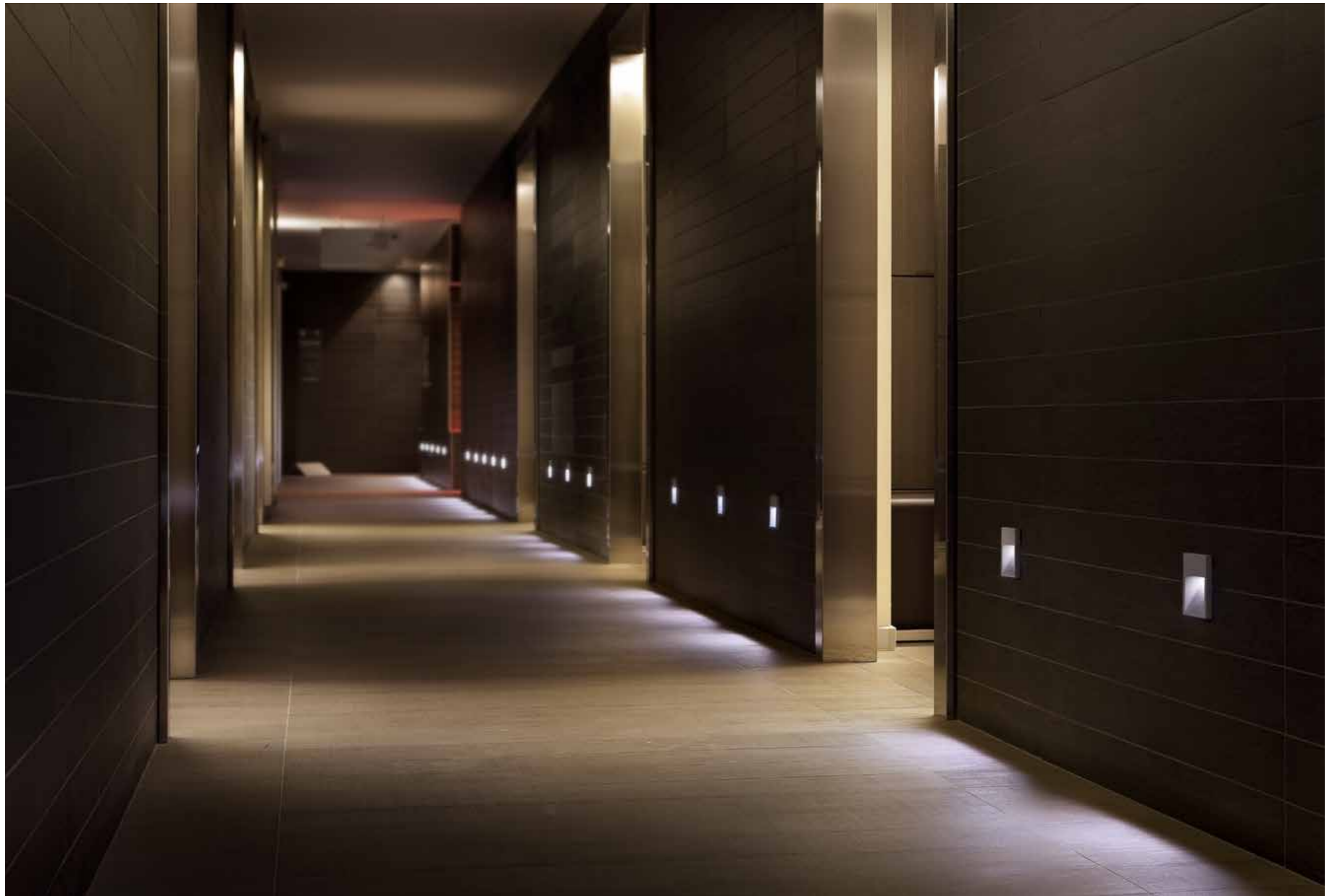

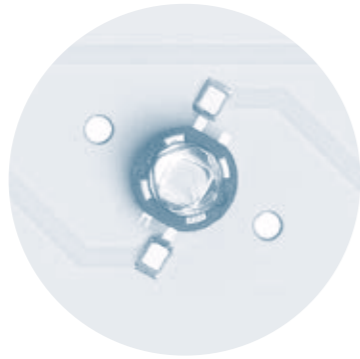
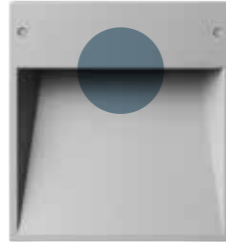

Power LED 2W mit Konstantstrom
500mA, Farbtemperatur 3000K.

2W Power LED, 500 mA constant cur-
rent, colour temperature of 3000K.



Zubehör aus Edelstahl für die Montage
auf Betonwänden mit Einbaurahmen aus
Thermoplastkunststoff. Dieses Zube-
hör ermöglicht sowohl den Halbeinbau
als auch den Wandanbau des gleichen
Produktes.



Accessory made of stainless steel for in-
stallation on cement walls, with thermo-
plastic frame for recessed installation. It
allows the product to be installed both as
a semi-recessed luminaire and as a wall
surface luminaire.

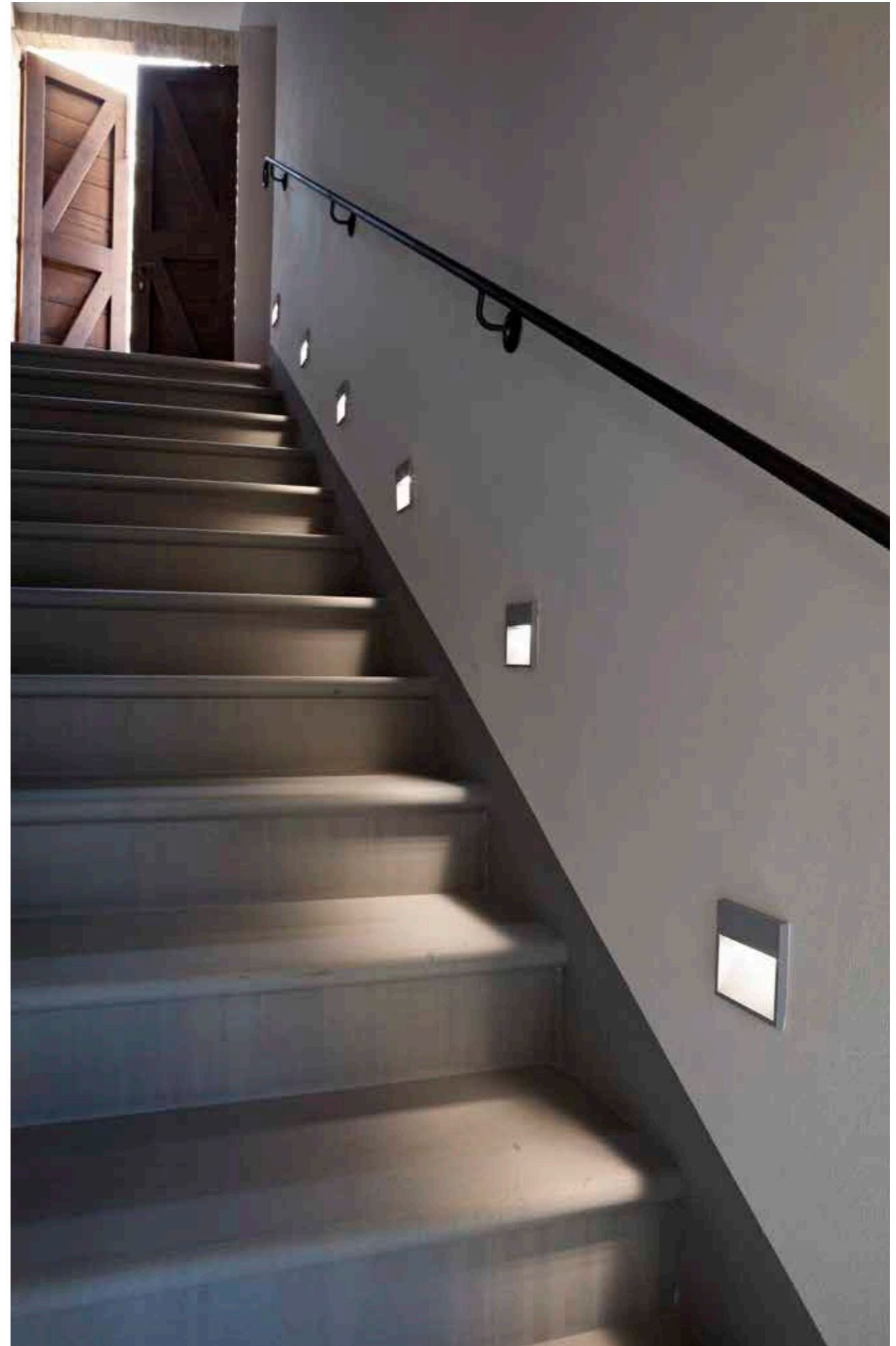

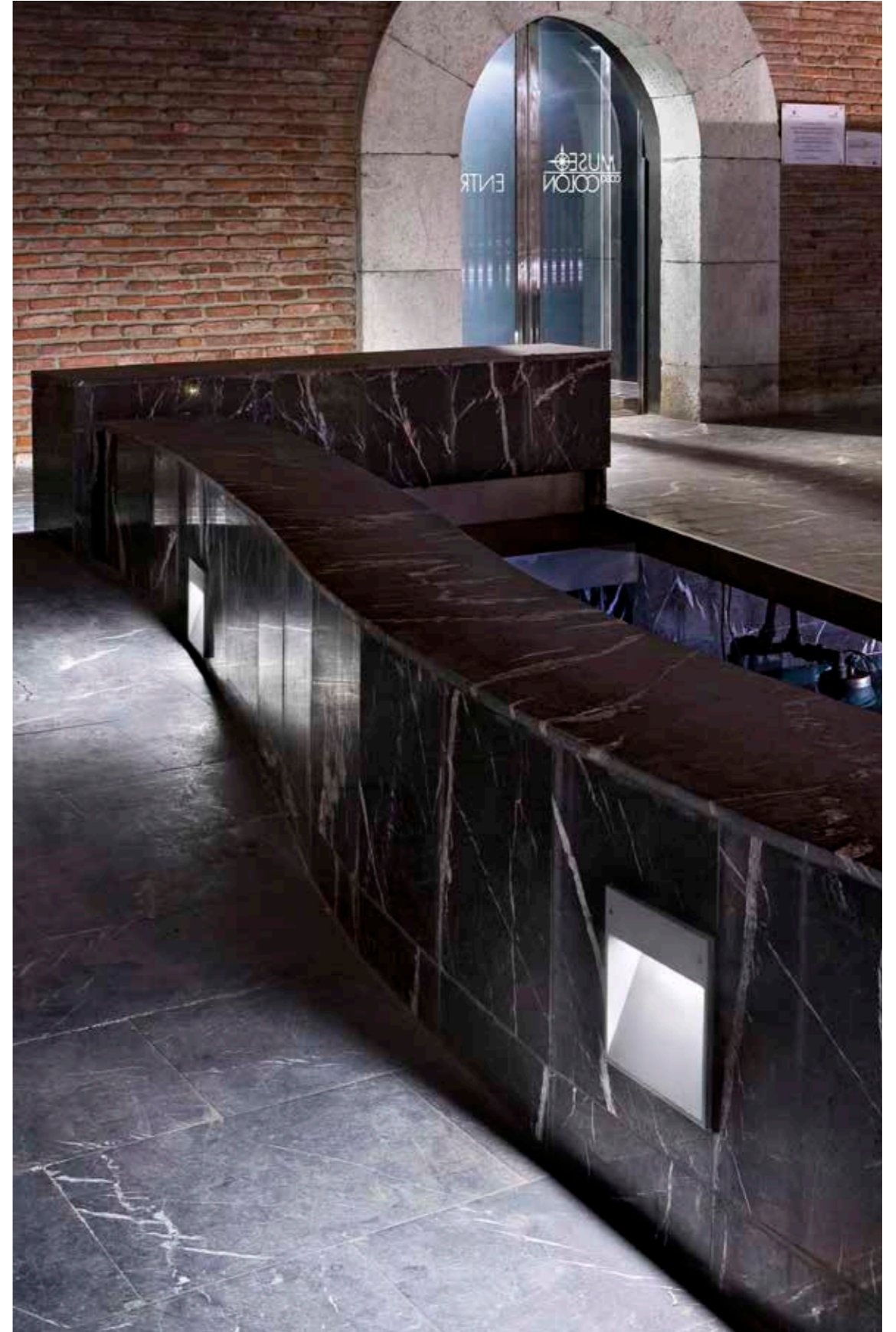

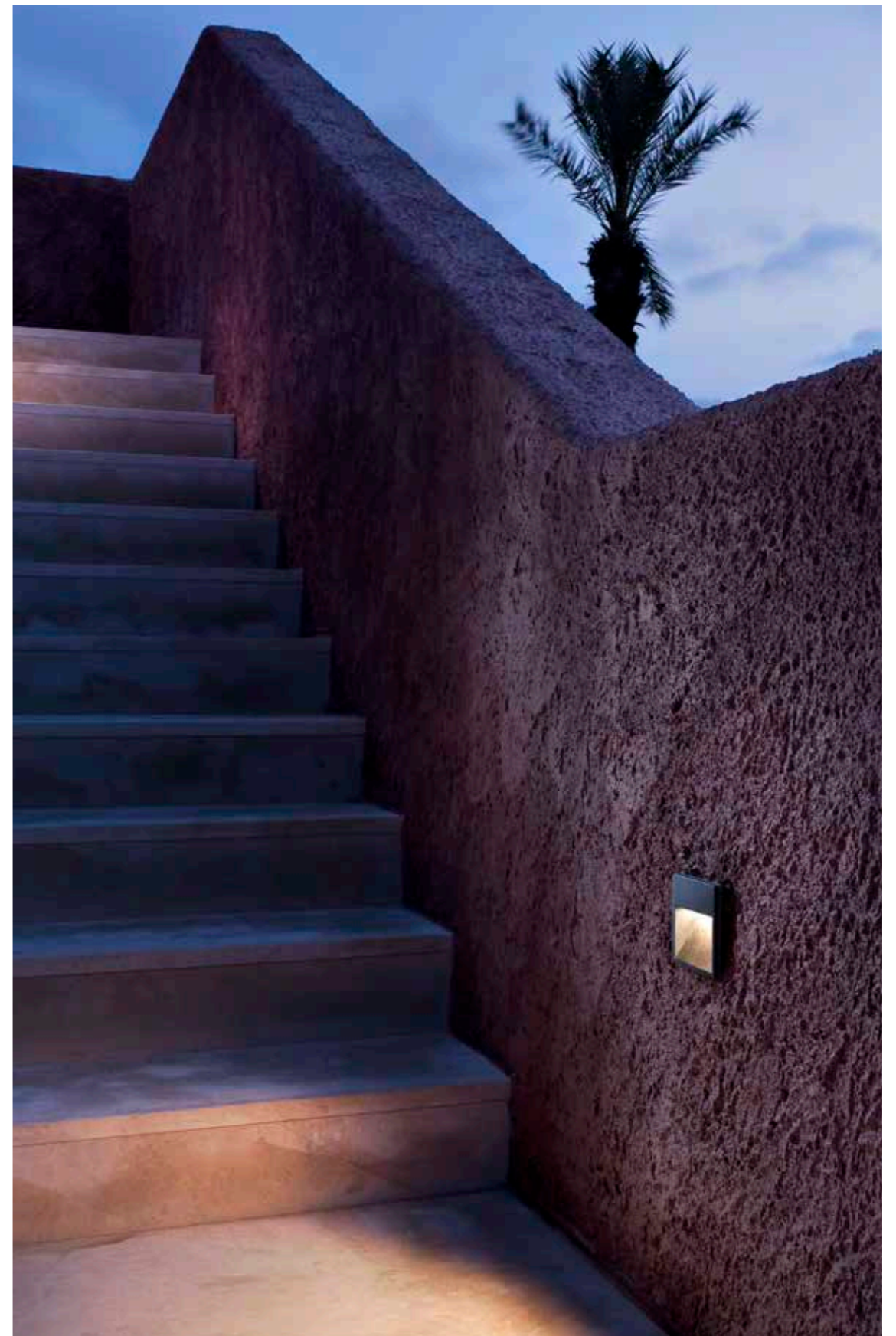
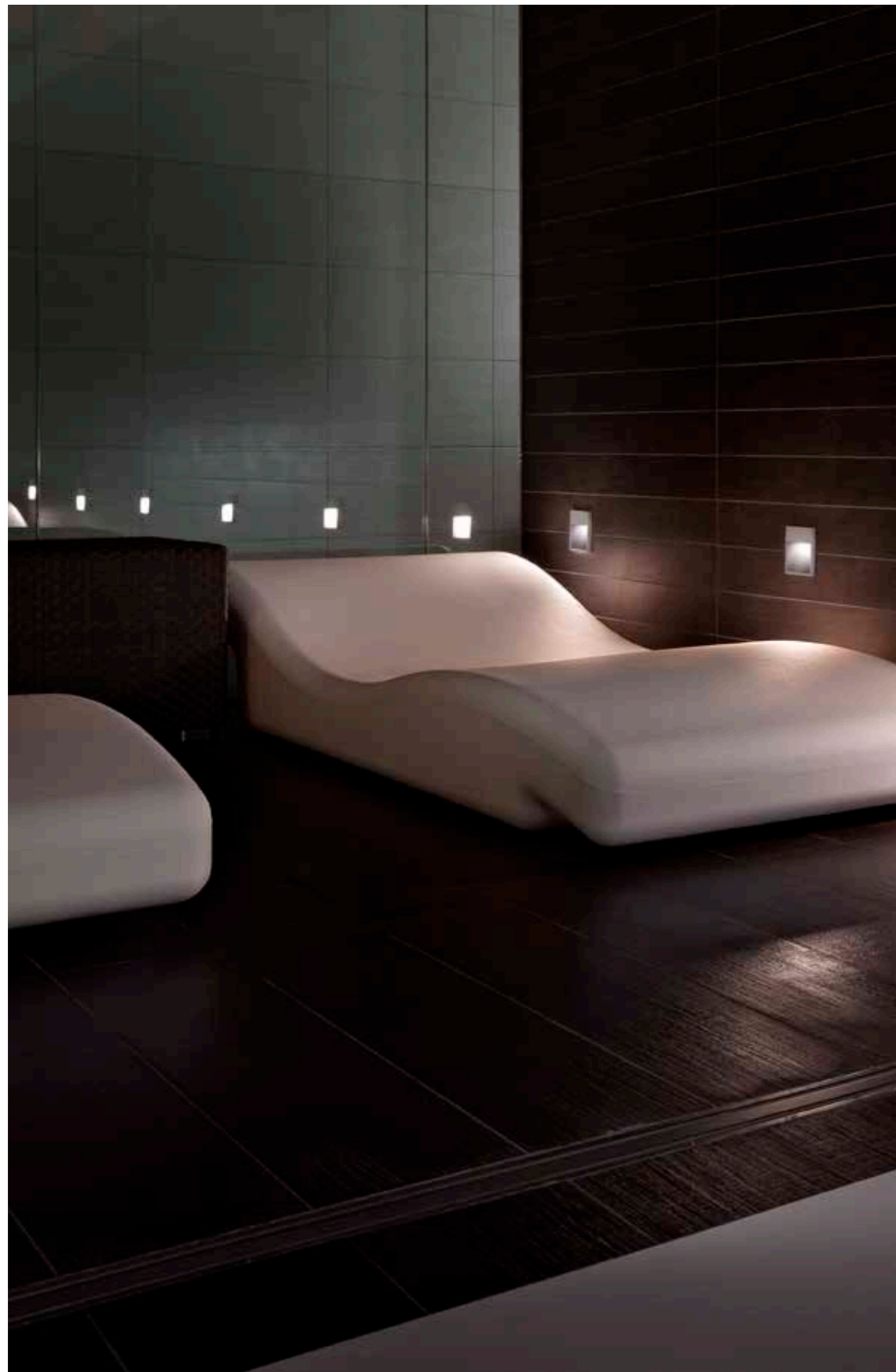

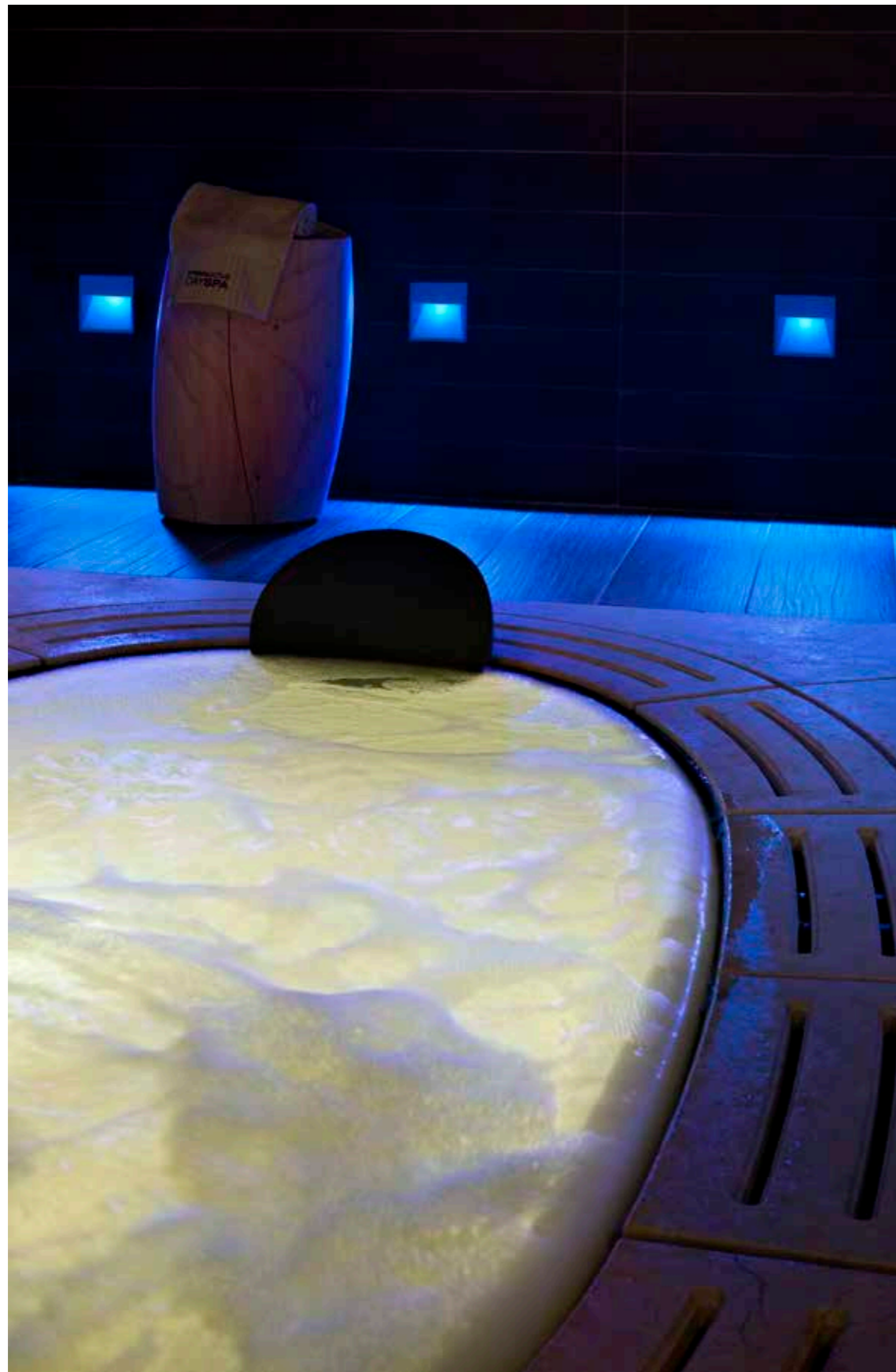

BOX



POWER LED
5W

TC-DEL
18/26W

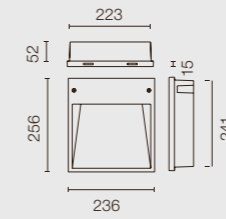

MINI BOX

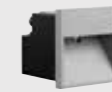

POWER LED
2W

QT-14
max25W

QT-9
20W

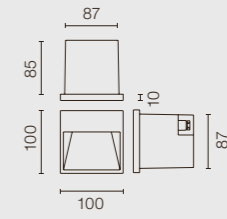

01 Mattweiss
01 Matt White

72 Grau
72 Grey

04 Mattschwarz
04 Matt Black

MM Dunkelbraun
MM Dark Brown



Juncos, Apps, Wall Rupture, Uso, Uso Cove Lighting,
Wall Piercing, Uso Boob, G-O In, Soft Spun,
Abajourd'hui, Teardrop, Usl Pluto, Round, Square
& Vertical Light, Usb Round & Square Light, Usb
Box, Softprofile, Kapprofile, Lightlight® In System
Profile, Usl Out, Usl 900 Disk.

SOFT ARCHITECTURE

SOFT ARCHITECTURE

Eine Natürliche Verbindung aus Material und Energie, Zwischen Licht und Architektur A Natural Fusion of Substance and Energy, between Light and Architecture

Liebe für Licht und Architektur ihre Verschmelzung mit den kreativsten Lösungen, Suche nach der modernsten Beleuchtungstechnik und absolute Umweltschönung: Flos Soft-Architecture ist die neue Philosophie, um die Verschmelzung von Stoff und Energie poetisch zu erleben.

Die Natur und ihr Gleichgewicht zu respektieren ihre Bedeutung zu verstehen und sich von ihrer Perfektion inspirieren zu lassen: Flos Soft-Architecture ist das Ergebnis langen Forschens nach der Verwendung von umweltfreundlichen Materialien (Cradle to Cradle-Zertifizierung) und Stoffen mit geringem Umwelteinfluss.

In einer perfekten Einigkeit von Stoff und Energie verwendet Flos Soft-Architecture die modernsten energiesparenden Lichtquellen (LED, LED mit Phosphorschicht, Power-LED, Kaltkathode, Kompaktleuchtstofflampen, Halogenlampen, IRC/ES) für eine perfekte Vereinigung von Licht, Architektur und Natur.

Loving light and architecture, melting them in the most creative solutions, looking for the most advanced, lighting and technical aims and fully respecting the environment: Flos Soft-Architecture is the new philosophy to live poetically the fusion of substance and energy.

Respecting nature and its balance understanding its value and being inspired by its perfection: Flos Soft-Architecture is the result of an in-depth lighting and technical research on the use of eco-friendly materials (certification Cradle to Cradle) with a low impact on the environment.

Flos Soft-Architecture is a perfect fusion of substance and energy and benefits of the most advanced energy saving sources (LED, Remote Phosphor LED, Power LED, cold cathode, compact fluorescent, halogens, IRC/ES) in order to grant a perfect integration of light, architecture and nature.

CRADLE TO CRADLE

“Respekt für die Natur und Natürliches Gleichgewicht” “Respecting Nature and its Balance”

Herstellung von Soft Architecture
Soft Architecture Manufacturing

Verkauf und Installation
Sale and Installation



Umweltschonendes Recycling
Relocation with no Environmental Impact

Umweltverträglicher Produktlebenszyklus
Sustainable Lifecycle

UNDER-COVER
technology

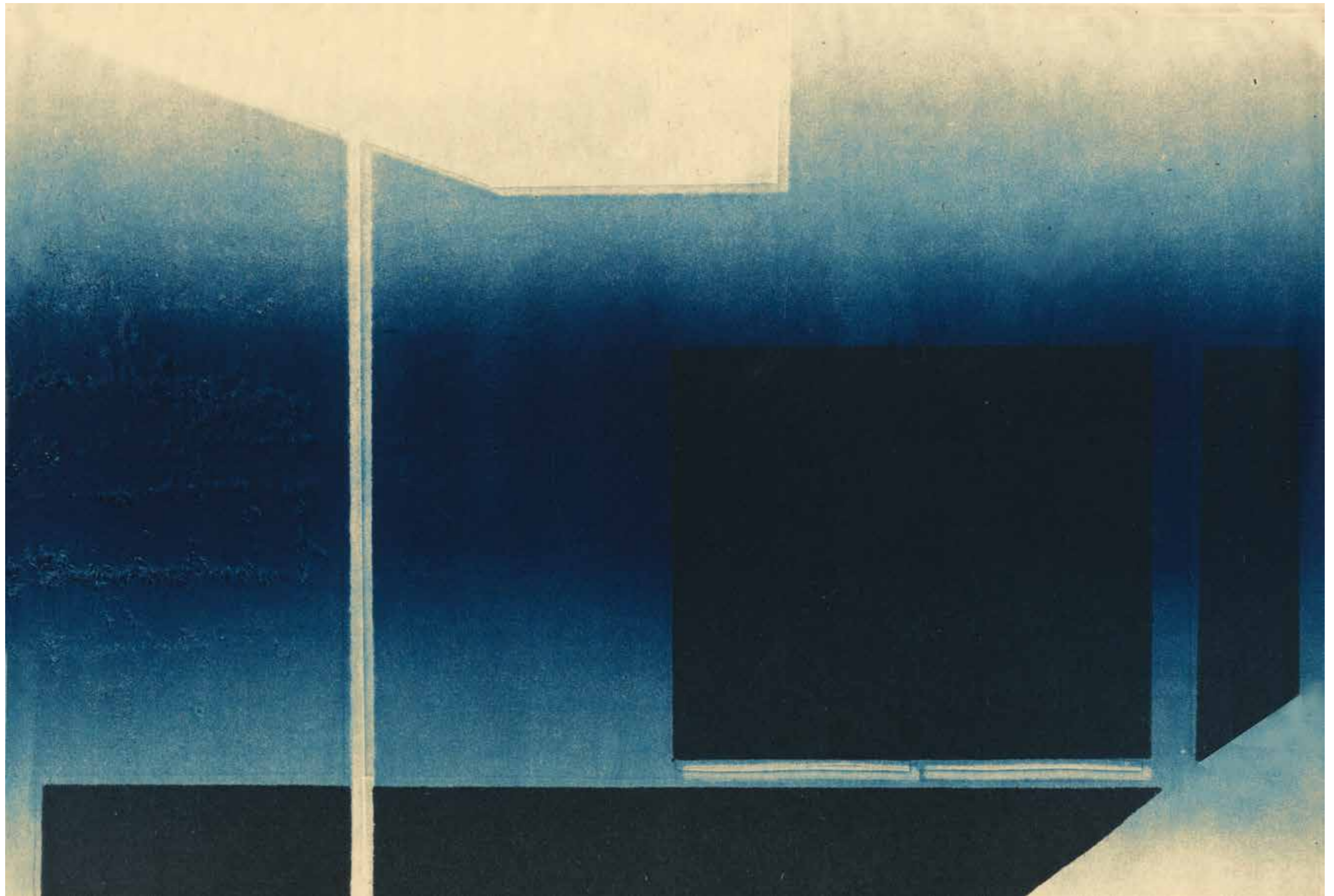

Als Inspiration diente für diese Leuchte das Schilfrohr, das aus dem Wasser ragt. Mit einem Hochleistungs-LED ausgestattet kann das Rohr geschwenkt werden und mehr oder weniger tief in die Decke eingeschoben werden, um den Lichtstrahl auszurichten und die gewünschte Komposition zu erzielen.

JUNCOS

Luminaire inspired by 'bunches of reeds' hovering over the water surface. With a high power LED, the tube can be tilted and inserted or removed from the ceiling to direct the beam of light and create the desired artistic composition.

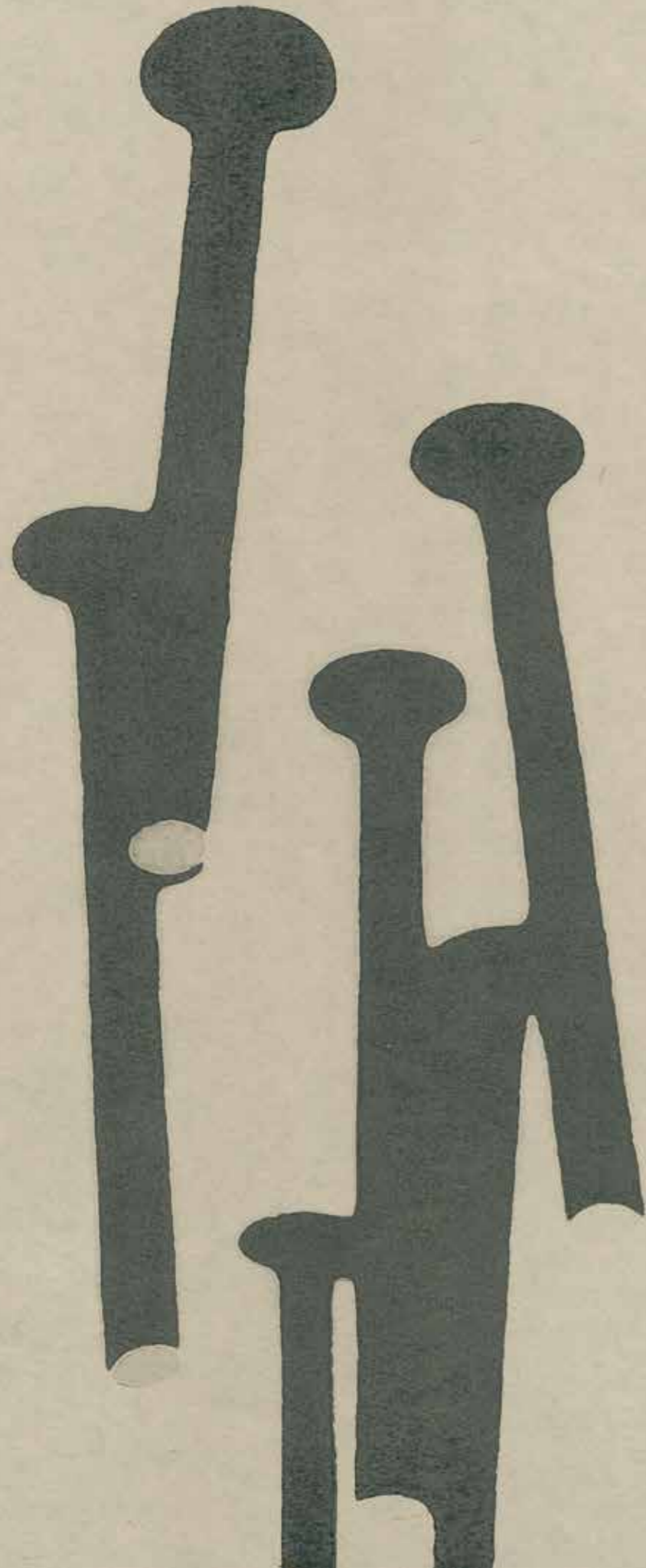



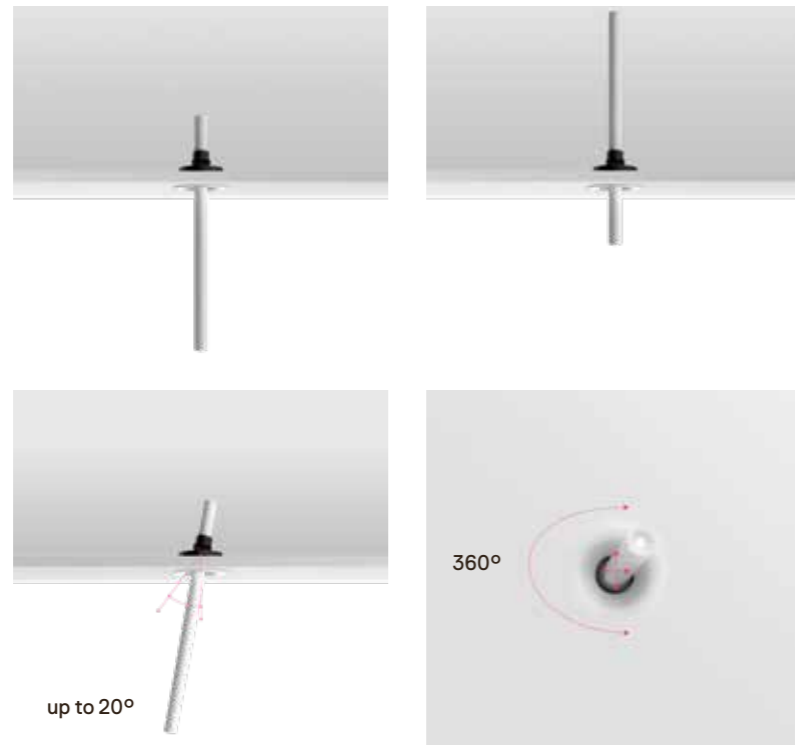

Mit einem in der Soft-Architecture-Platte eingebauten Gelenkmechanismus lässt sich das Rohr einfahren und herausziehen sowie bis zu 20 Grad von der Vertikalachse aus schwenken.

Bei der Lichtquelle handelt es sich um ein Power LED mit 9W für einen Lichtstrom von 700 lm, die dank einer hochwertigen Spot Lens eine optimale Lichtverteilung gewährleistet.

Das Aluminiumrohr und der interne Kühler bieten eine optimale Abgabe der von der LED erzeugten Wärme. Somit wird Überhitzung vermieden und die LED bietet optimale Leistung bei verlängerter Lebensdauer.

Der modulare Aufbau der Rohre (1, 3, 6 und 9) ermöglicht eine Vielzahl von Konfigurationen mit einer ungeordneten Verteilung in Anlehnung an das Schilfrohr im Wasser. Sollte eine "geordnete" Konfiguration bevorzugt werden, kann das Modul mit einem Rohr mehrmals in einer Reihe oder bestimmten Form angeordnet werden.

By a hinge system, installed on the Soft architecture plate, the "reed"-tube can be moved in or out as well as tilted up to 20 degrees on the vertical axis.

The light source is a 9W Power LED emitting a luminous flux of 700lm, which, using a high quality spot lens, provides optimal light distribution.

The aluminium tube and the internal radiator heat prevent the overheating produced by the LED light source. It favours optimal performance and extends the life of the LED.

The Junco modules (1, 3, 6 and 9 tubes) allow for the creation of an infinite number of configurations, imitating the disorderly distribution of reeds in water. If an "orderly" configuration is preferred, then use the 1-tube Junco module and install it forming a straight line or a matrix.

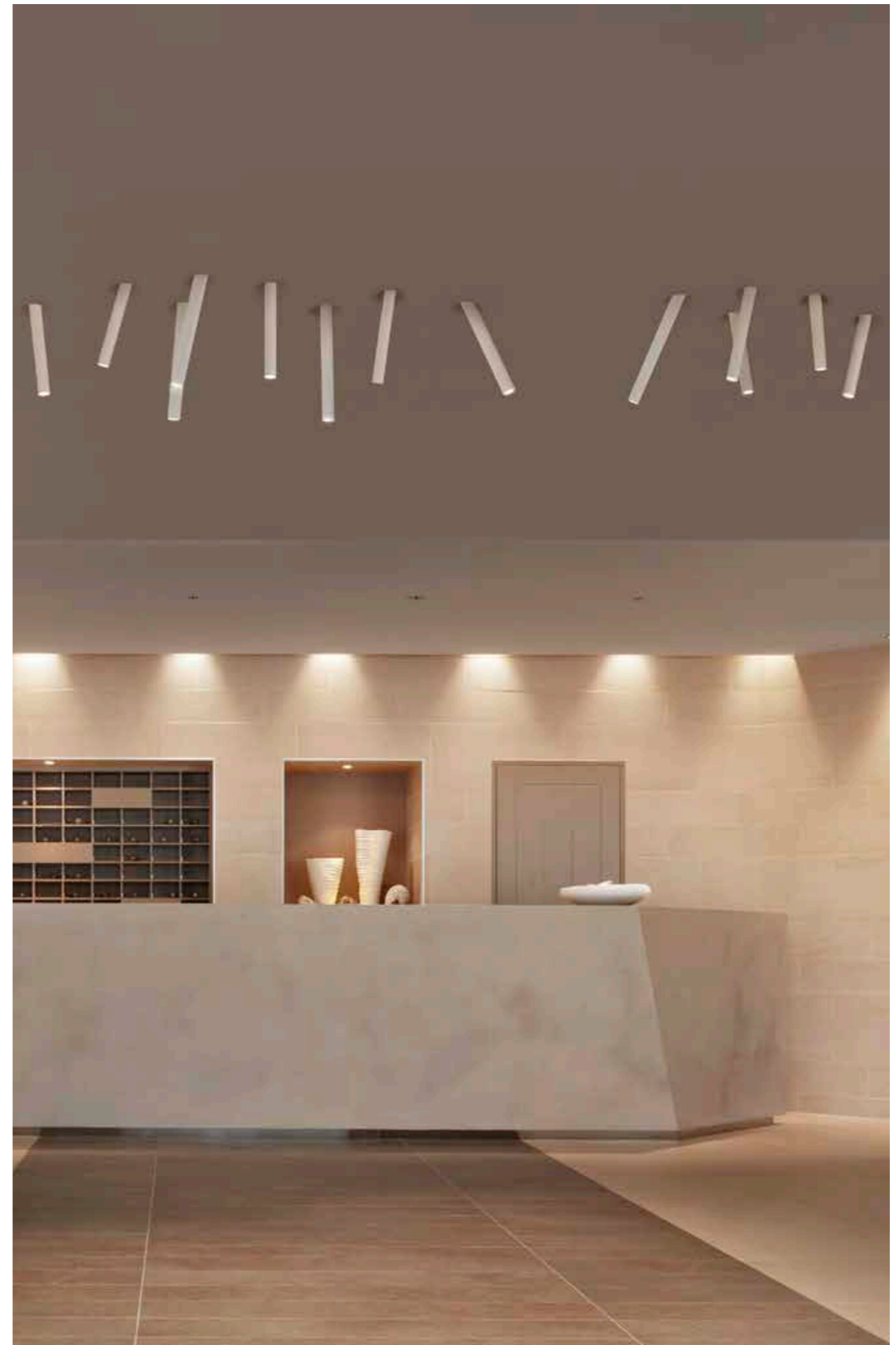





JUNCOS 1L

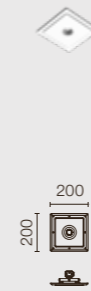

JUNCOS 3L

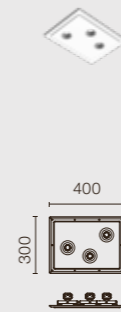

JUNCOS 6L

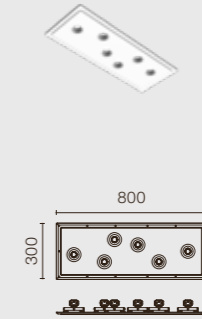

JUNCOS 9L

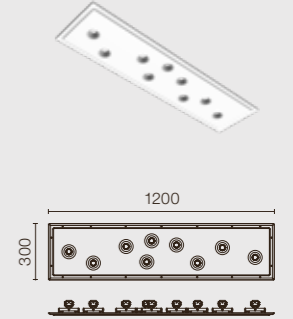

JUNCOS 250mm



JUNCOS 400mm

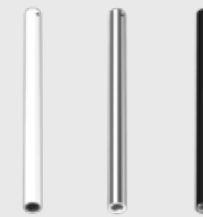

POWER LED
2,1W

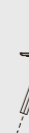
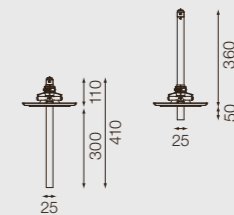
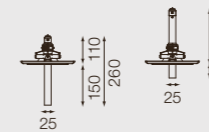

Wandleuchte mit minimalem visual Impact zur Raumkennzeichnung mit LED-Lichtquellen. Absolut customisierbar und auch als Notbeleuchtung erhältlich. Die indirekte Rundumbeleuchtung ist in drei Farben erhältlich: Weiß, Orange und Violett.

APPS

Wall luminaire with minimal visual impact for the signage of spaces with LED light sources. Completely customisable, it is also available in emergency version. Indirect perimeter light, available in three colours: white, orange and violet.

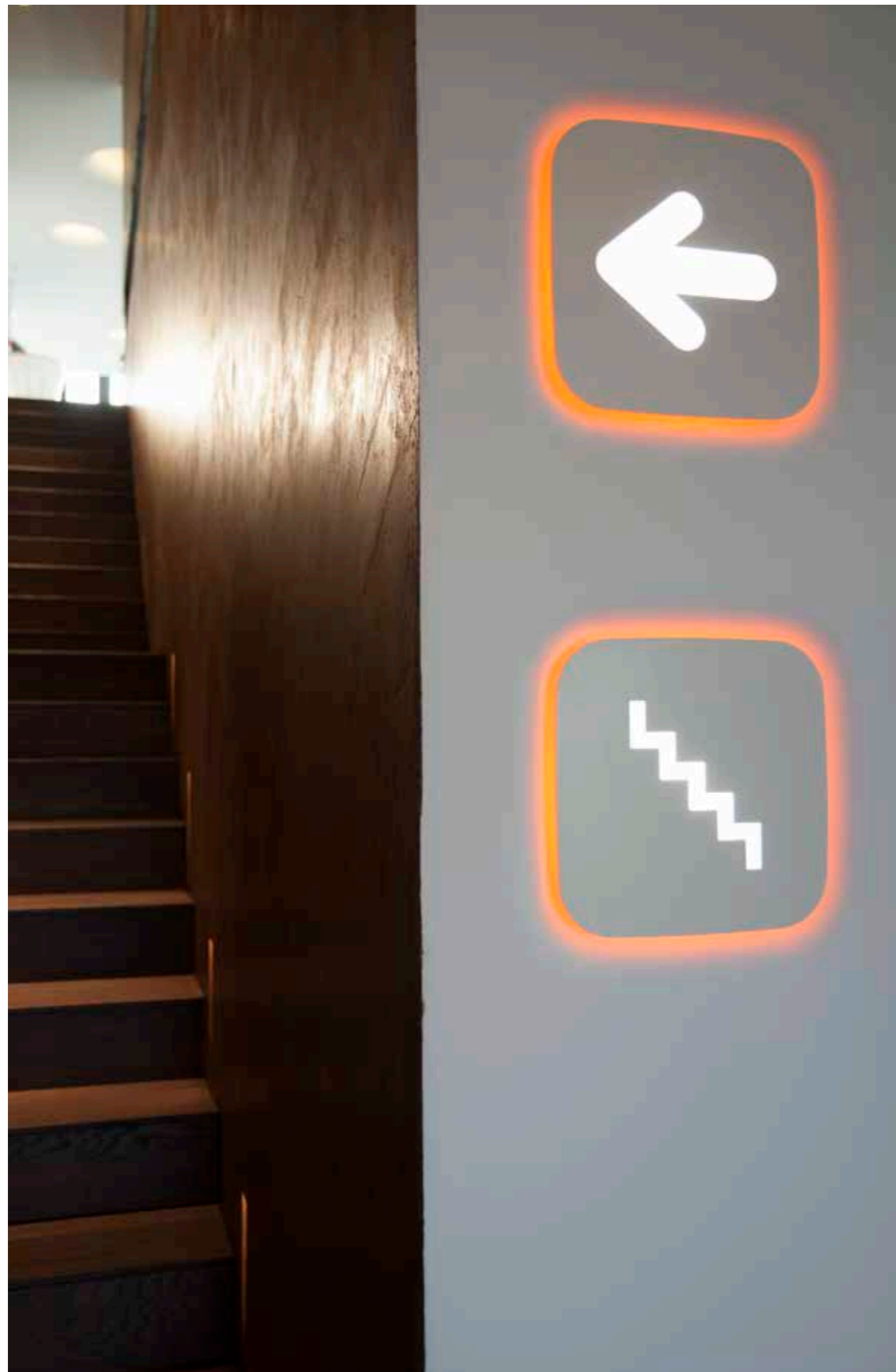

626

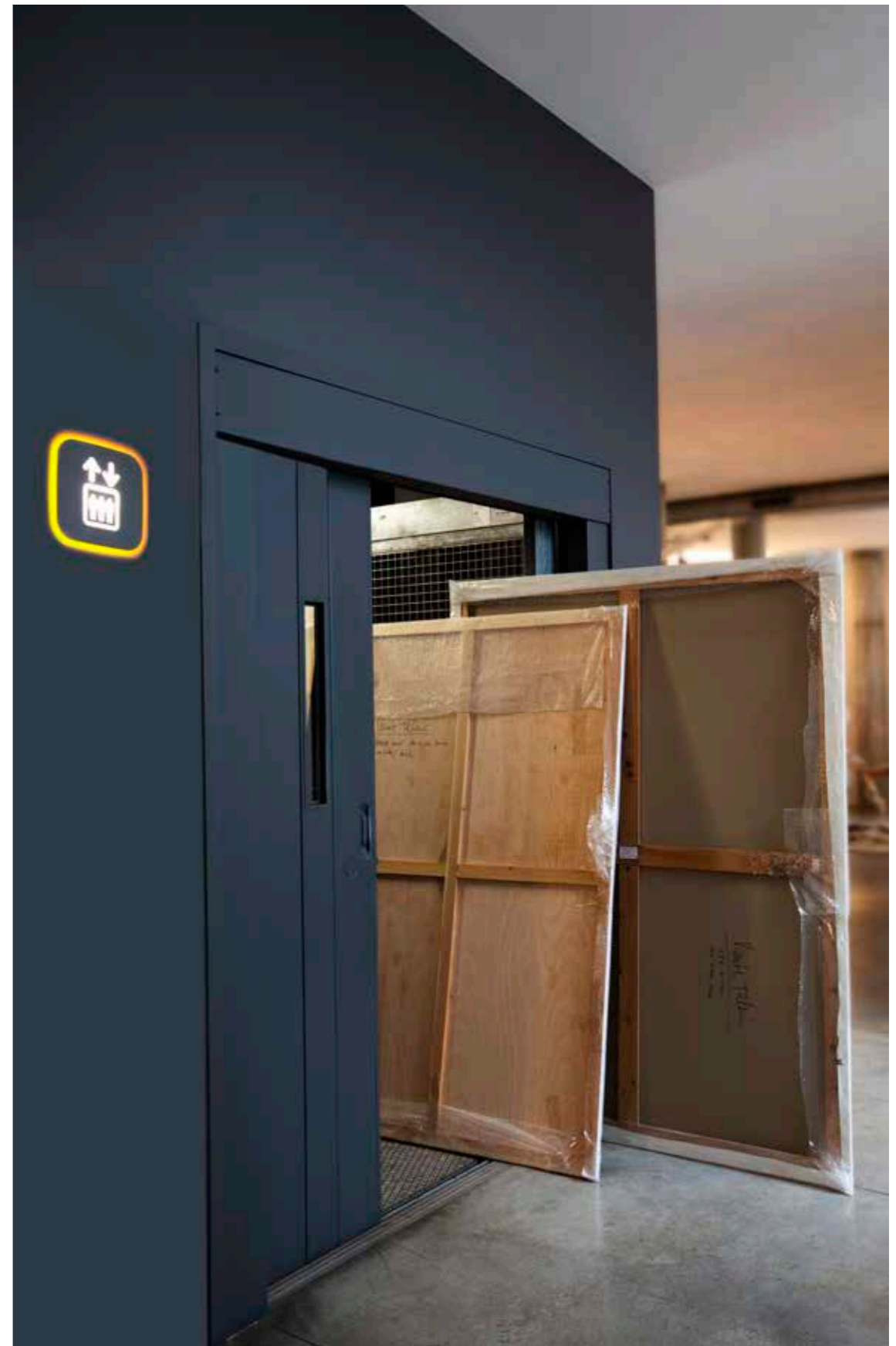

627

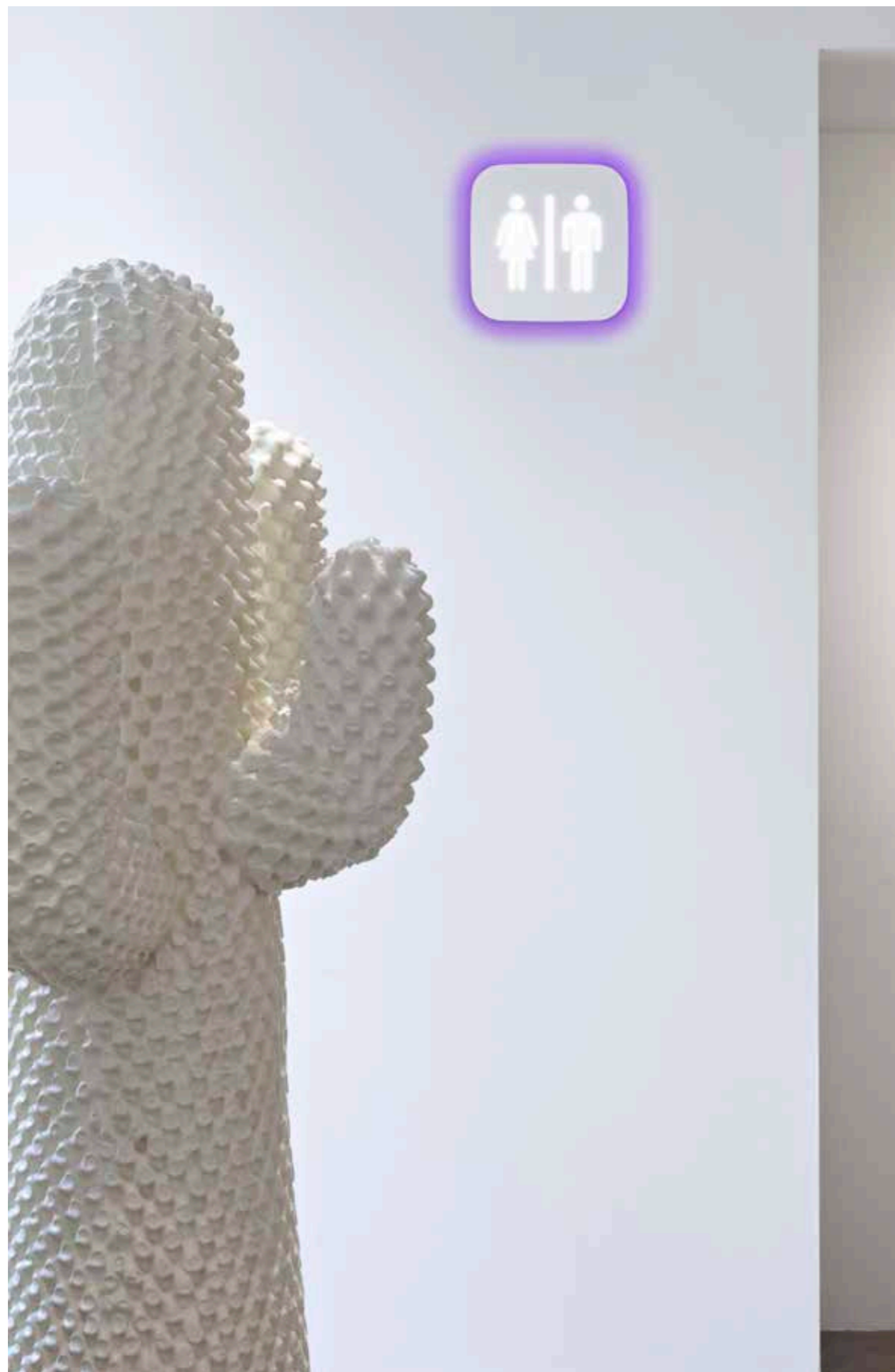

APPS

APPS EMERGENCY

LED ARRAY 4W

| | | | | | | | |
|---------|---------|-----------------|----------|---------|--------------|------------|------------|
| | | | | | | | |
| 90° Dir | 45° Dir | Wc Ladies | WC Men | 90° Dir | 45° Dir | Exit Right | Exit Left |
| | | | | | | | |
| Wc | Bar | Restaurant | Elevator | Exit | Extinguisher | Fire Hose | Fire Alarm |
| | | | | | | | |
| Info | Stairs | *Your Custom Id | | | | | |

Perimetrales Licht
Peripheral Lighting Colours

| | | |
|---|---|--|
| <input type="checkbox"/> Weiss White | <input type="checkbox"/> Orange Orange | <input type="checkbox"/> Violett Violet |
|---|---|--|



Wall Rupture ist eine unsichtbare Leuchte aus Soft Composite. Der Effekt erinnert an eine geheime Falte in der Wand, die das unregelmäßige Relief der Erde verbirgt. Erhältlich in Gold und in Silber. Enthält LED-Streifen mit unterschiedlichen Farbtemperaturen: 2700K (Deko-Version Gold) oder 5000K (Deko-Version Silber).

WALL RUPTURE

Wall Rupture is an invisible luminaire made of Soft Composite. The effect is like a secret fold in the wall that conceals the irregular relief of the earth. Available in gold and silver. It incorporates LED strips with different colour temperatures: 2700K (gold version) or 5000K (silver version).

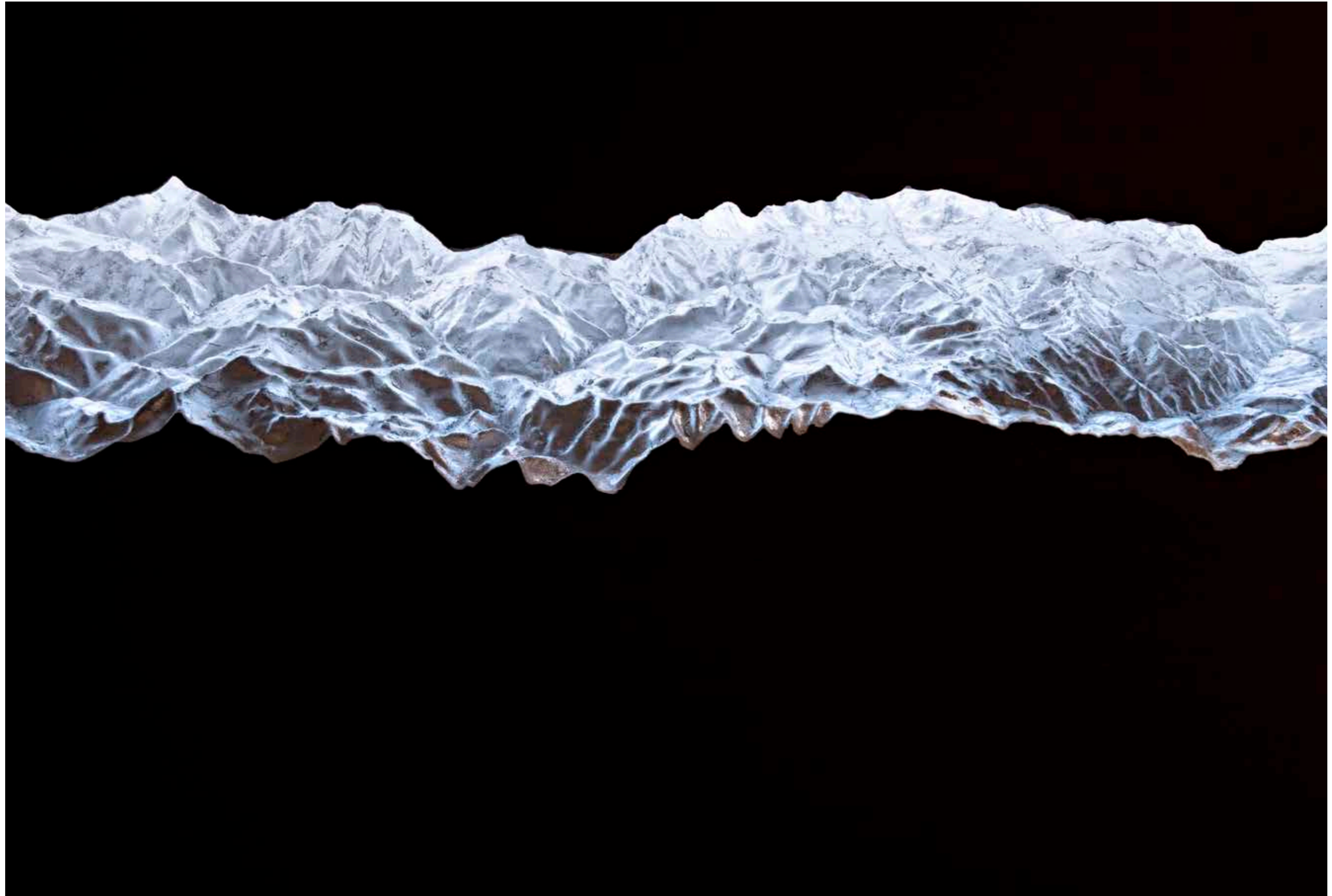

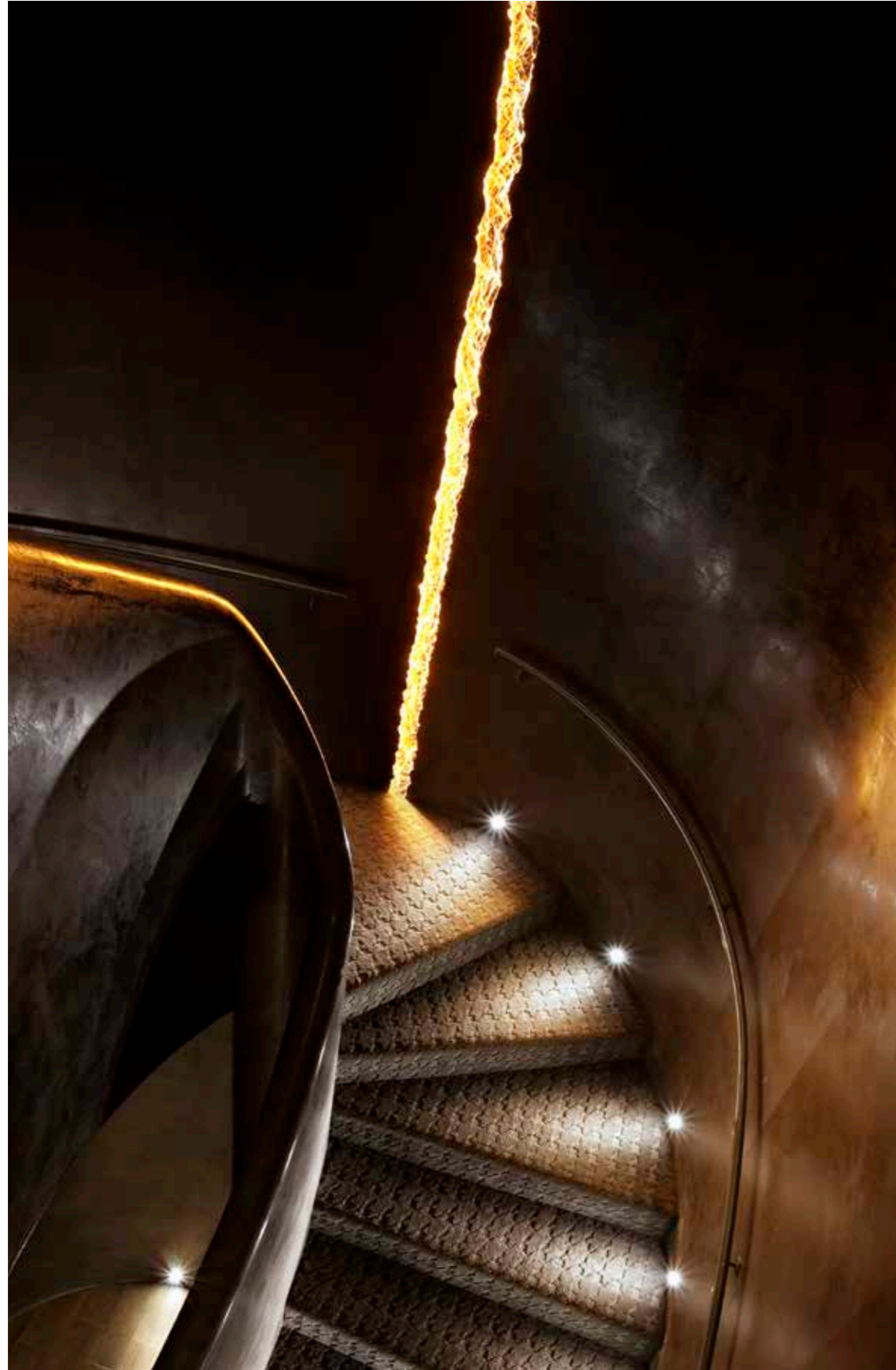

WALL RUPTURE

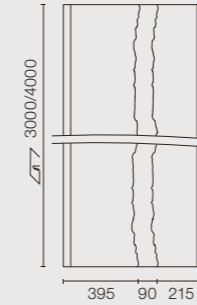

WALL RUPTURE WITH END CAPS

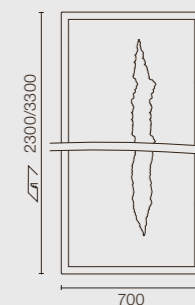

LED WHITE
17,5W/m



Produktfamilie von mit Soft Composite Technologie gefertigten Leuchten für FLOS architectural Projekte. Erhältlich in verschiedenen Größen und Formen sowie in Version 1L und 2L, bietet die Uso-Familie eine breite Palette an Beleuchtungslösungen unter Gewährleistung der totalen Integration in den Architekturraum.

USO

Family of luminaires manufactured with Soft Composite technology and designed to house FLOS architectural project. Available in several sizes and shapes, as well as in 1L and 2L versions, the Uso family offers a wide variety of lighting solutions, always guaranteeing total integration into the architectural space.

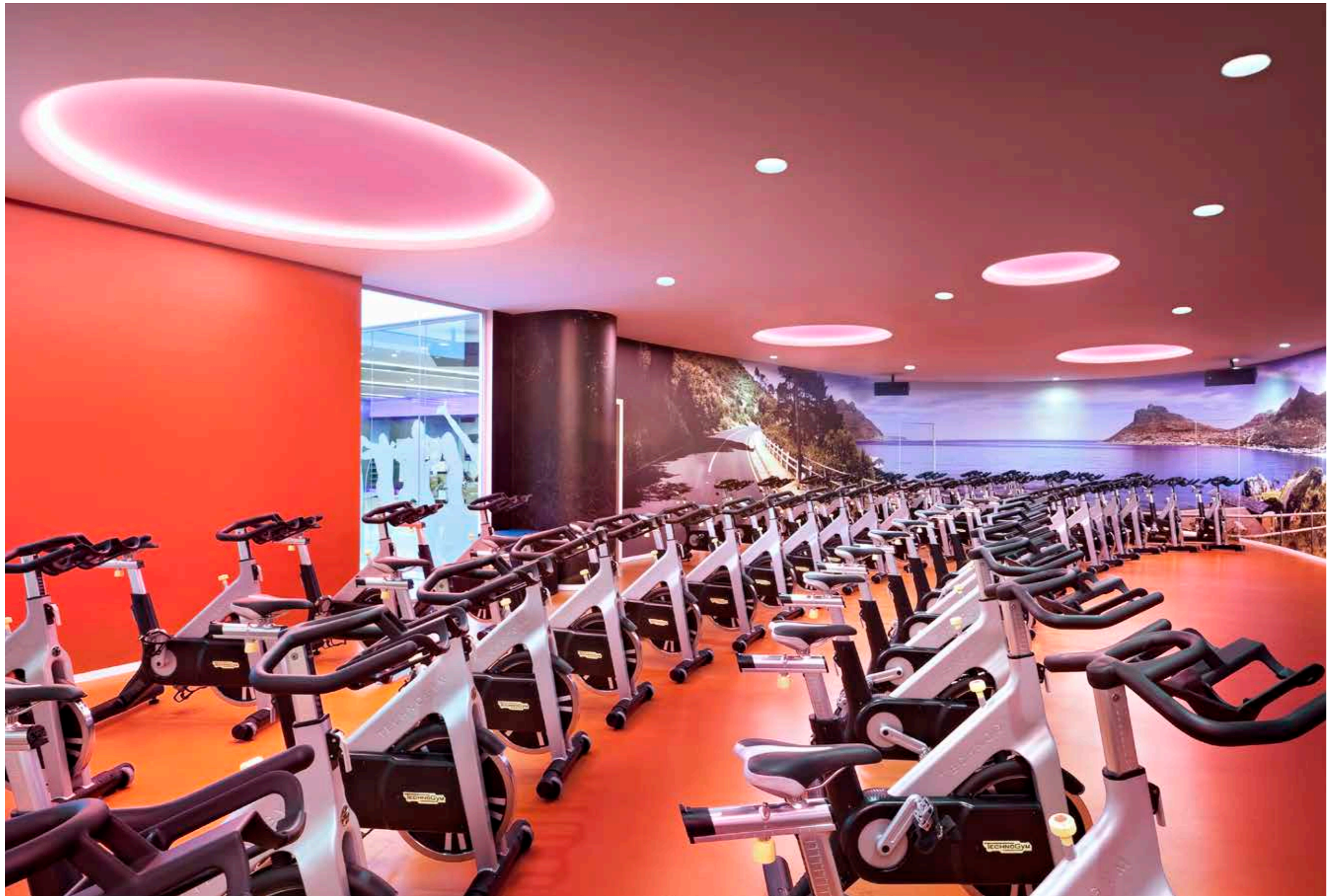



640



641

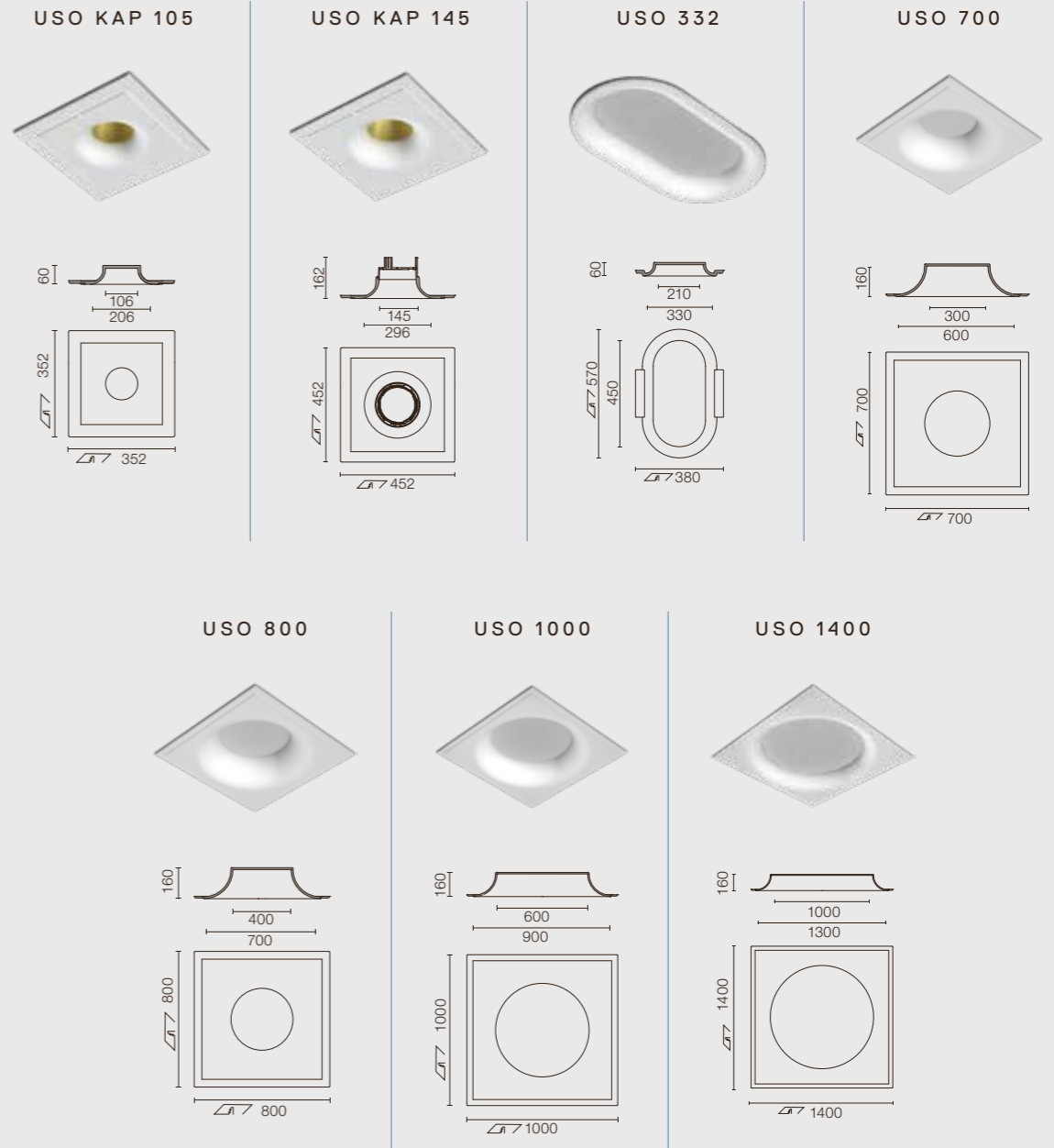

USO 900
COVE LIGHTING



T5 FH
21W

T5 FQ
39W

COLD CATHODE
90W
3x30W

LED WHITE
49W
14x3,5W

LED RGB
24,5W
14x1,75W

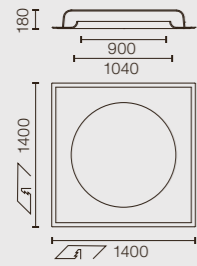

USO 1700
COVE LIGHTING



T5 FH
21W

T5 FQ
39W

COLD CATHODE
161W
4x40W

LED WHITE
91W
26x3,5W

LED RGB
45,5W
26x1,75W

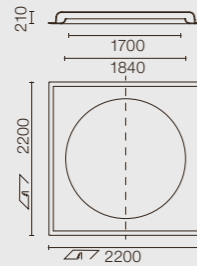

USO 2200
COVE LIGHTING



T5 FH
28W

T5 FQ
54W

COLD CATHODE
205W
4x51W

LED WHITE
112W
32x3,5W

LED RGB
56W
32x1,75W

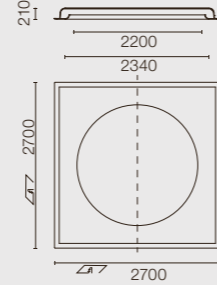

USO 2500
COVE LIGHTING



T5 FH
28W

T5 FQ
54W

COLD CATHODE
230W

LED WHITE
126W
36x3,5W

LED RGB
63W
36x1,75W

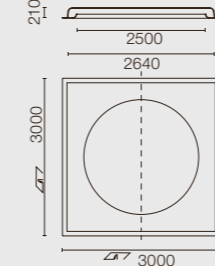

USO 100 50
COVE LIGHTING



T5 FH
14W

T5 FQ
24W

COLD CATHODE
58W
3x19W

LED WHITE
28W
8x3,5W

LED RGB
14W
8x1,75W

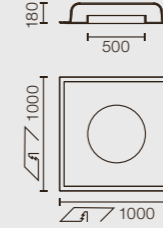

USO 140 90
COVE LIGHTING



T5 FH
21W

T5 FQ
39W

COLD CATHODE
90W
3x30W

LED WHITE
49W
14x3,5W

LED RGB
24,5W
14x1,75W

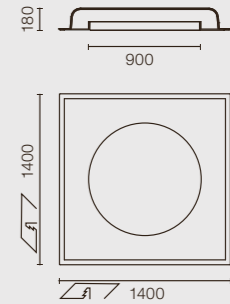

LED-Wandlampe, konzipiert für minimalen visual Impact durch Integration in die Wandfläche. Installation auf Ebene des Wandverputzes. Ring aus Aluminium mit Diffusor aus Polycarbonat. Problemloser Stromanschluss und einfache Installation dank Steckerhülsen und Kunststoffbügeln.

WALL PIERCING

LED wall lamp designed for minimal visual impact integrated into wall. Flush-mounted on plasterboard wall. Aluminium ring with polycarbonate diffuser. Fast electrical installation with female connectors and plastic hooks for easy installation.



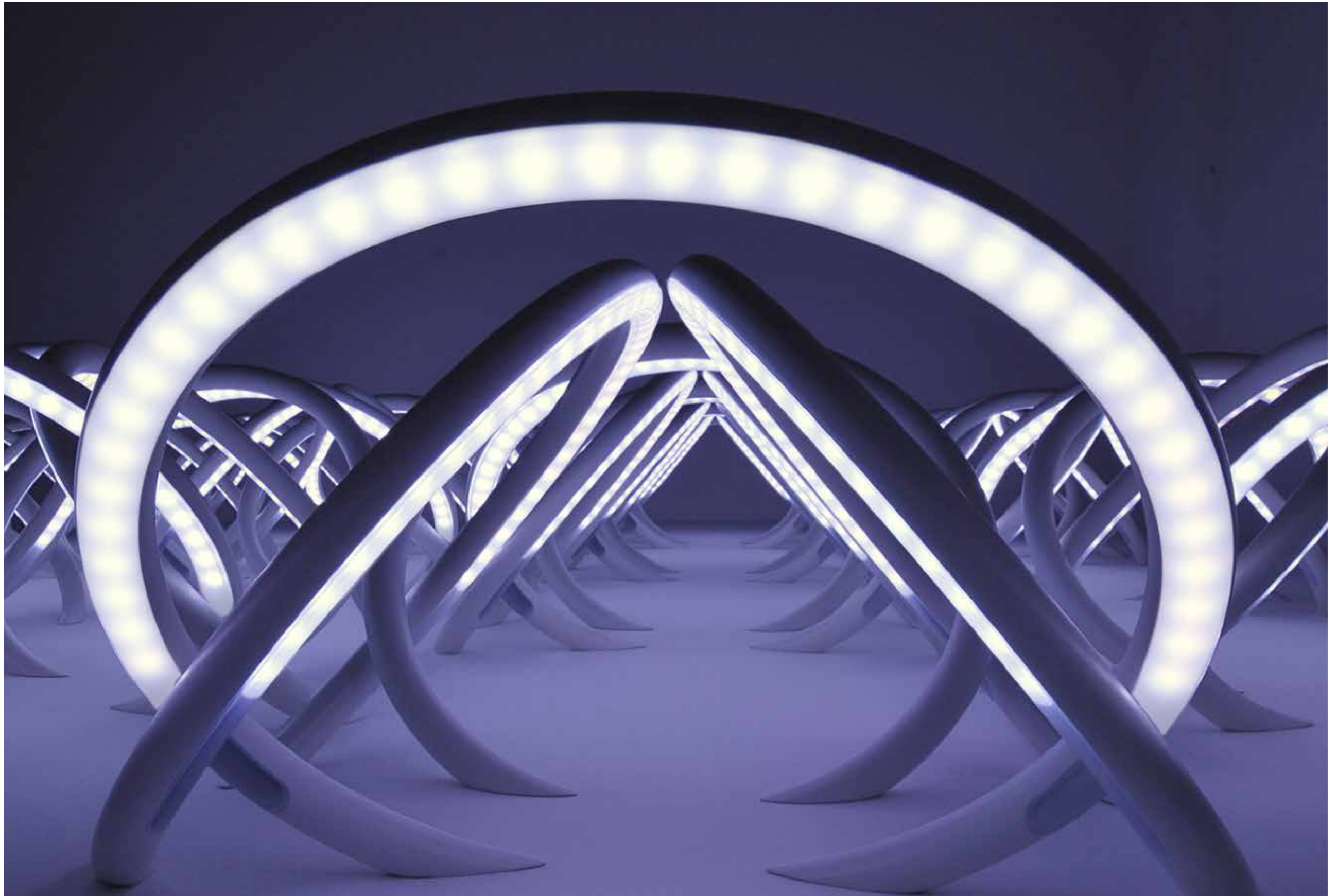

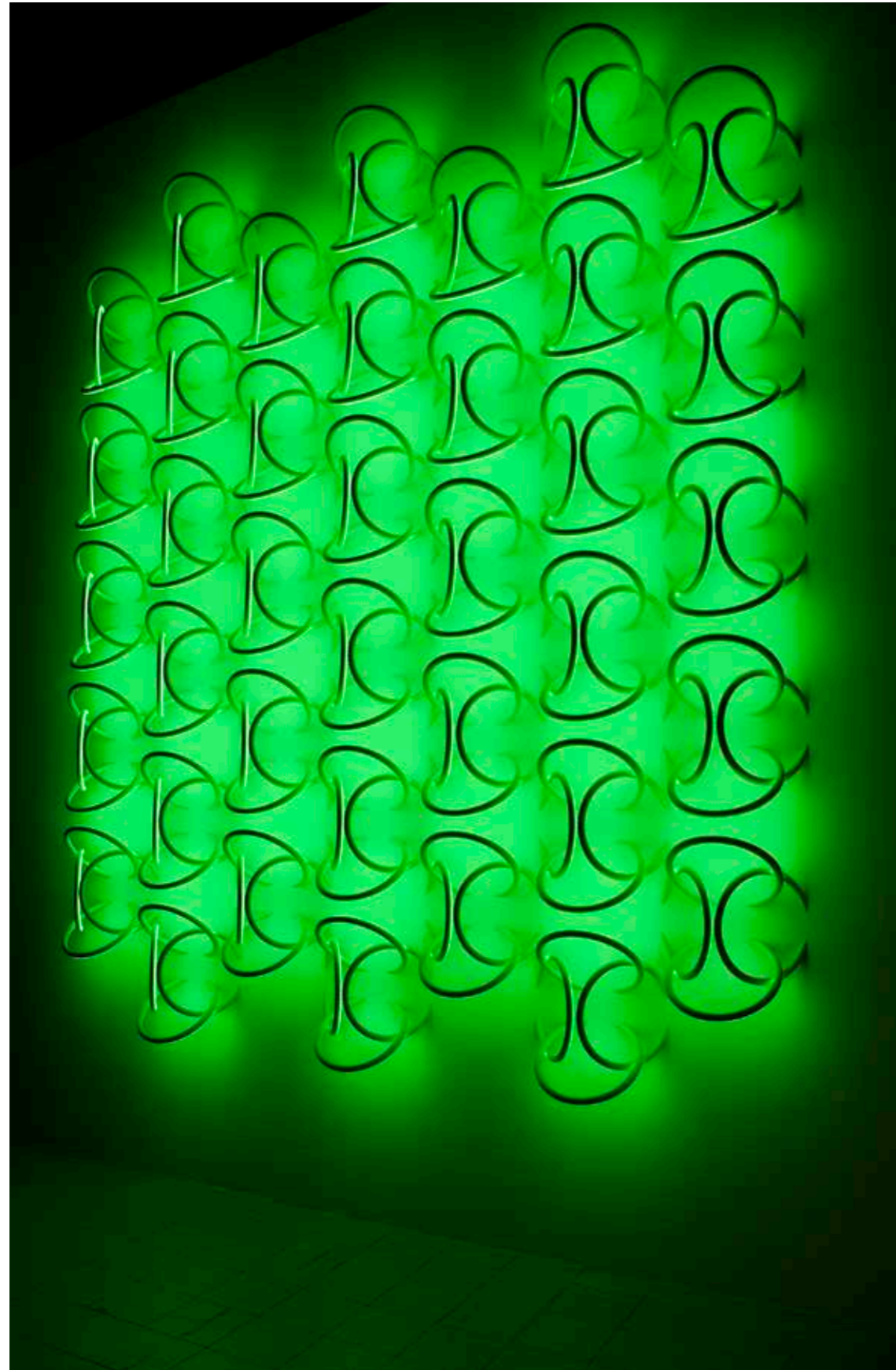

650



651



WALL PIERCING 1X



LED WHITE 1x6,4W LED RGB 1x7,4W

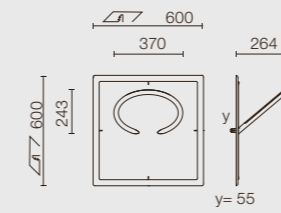

WALL PIERCING 2X



LED WHITE 2x6,4W LED RGB 2x7,4W

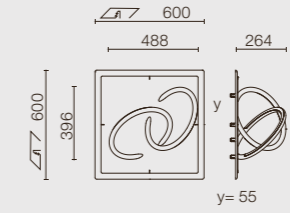

WALL PIERCING 4X



LED WHITE 4x6,4W LED RGB 4x7,4W

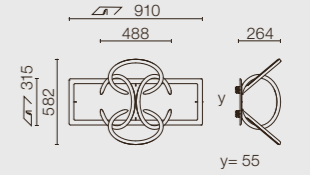

WALL PIERCING 2X LINE



LED WHITE 2x6,4W LED RGB 2x7,4W

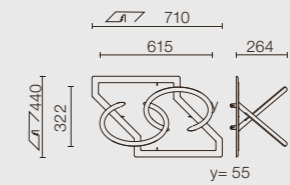

Beleuchtungssystem aus Soft Composite, das an der Geometrie eines umgekehrten Vulkans inspiriert ist. Erhältlich in zwei Größen mit 1 bzw. 2 Spots. USO Boob wurde speziell entwickelt, um damit FLOS architectural Produkte zu verwenden.

USO BOOB

Lighting made of Soft Composite inspired by the geometry of an inverted volcano. Available in two sizes and in 1/2 spot version. Uso Boob is specifically designed to house FLOS architectural products.

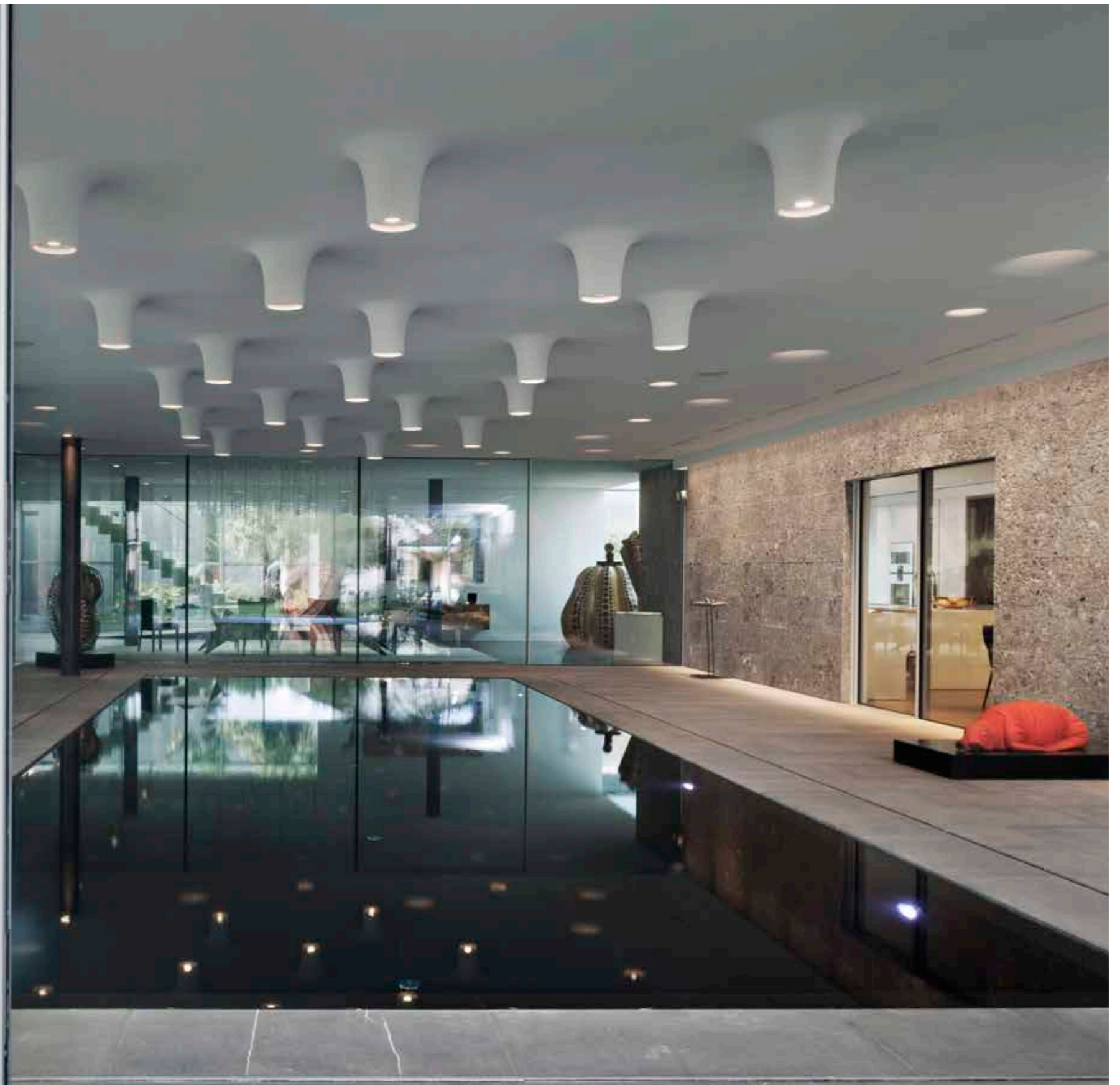

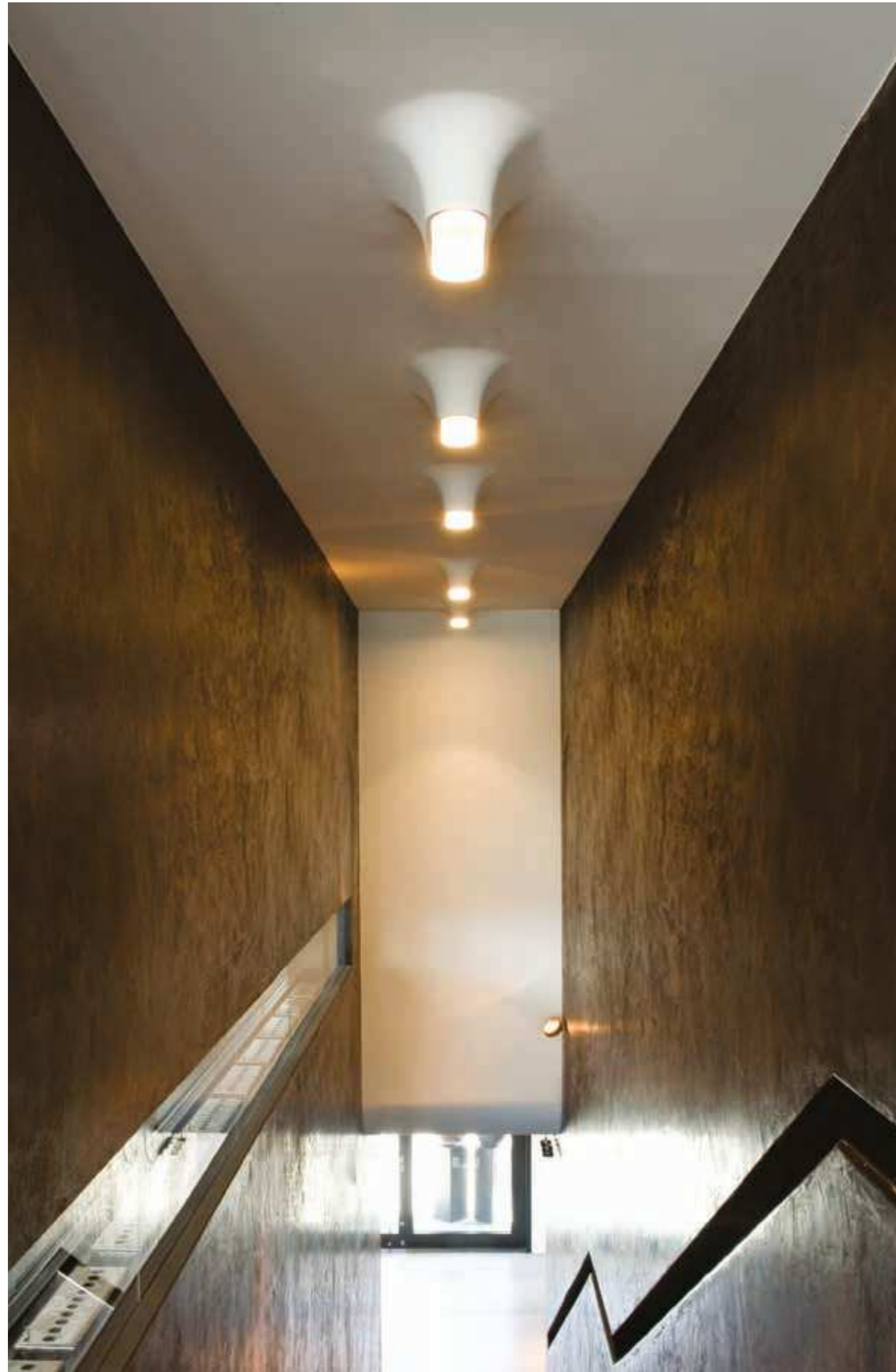

USO BOOB 600 1L

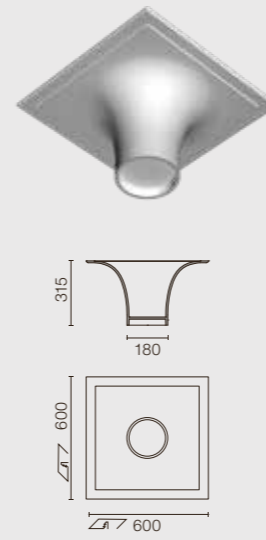

USO BOOB 600
FOR MODULAR CEILING

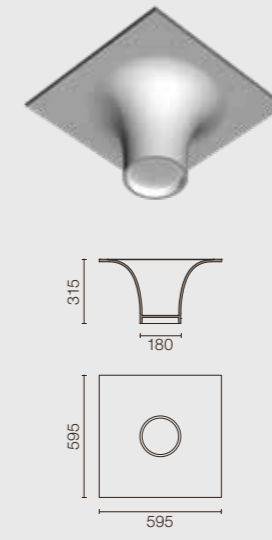

USO BOOB 600 2L

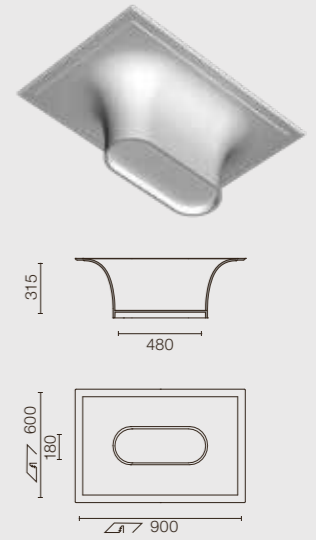

USO BOOB 100 1L

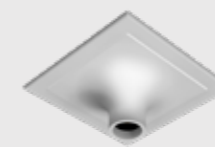

QR-CBC-51
max 50W

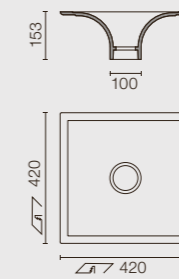

LED-Wandleuchte, speziell entwickelt für die Orientierungsbeleuchtung in Innenräumen wie Fluren, Treppen etc. Mit Soft Composite Technologie konzipiert, fügt sie sich perfekt in den Architekturraum ein. Erhältlich mit weißem, orangefarbenen oder blauem Licht je nach den Vorgaben des Beleuchtungsprojekts.

G-O IN

LED wall luminaire, specifically designed for indoor signage of corridors, stairs, etc. Fitting combined with Soft Composite technology integrates perfectly into the architecture. Available with white, amber or blue light depending on the needs of the lighting project.

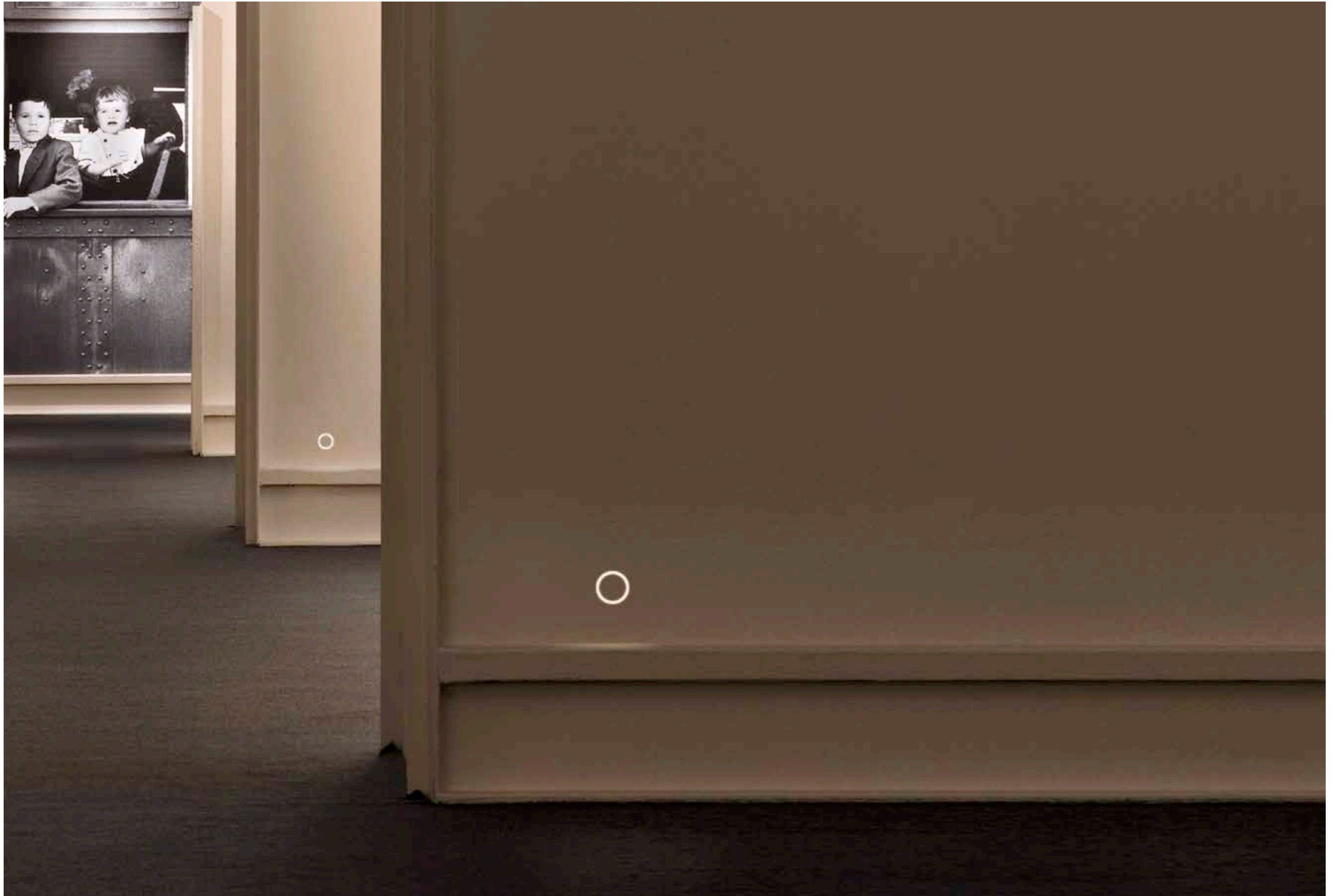

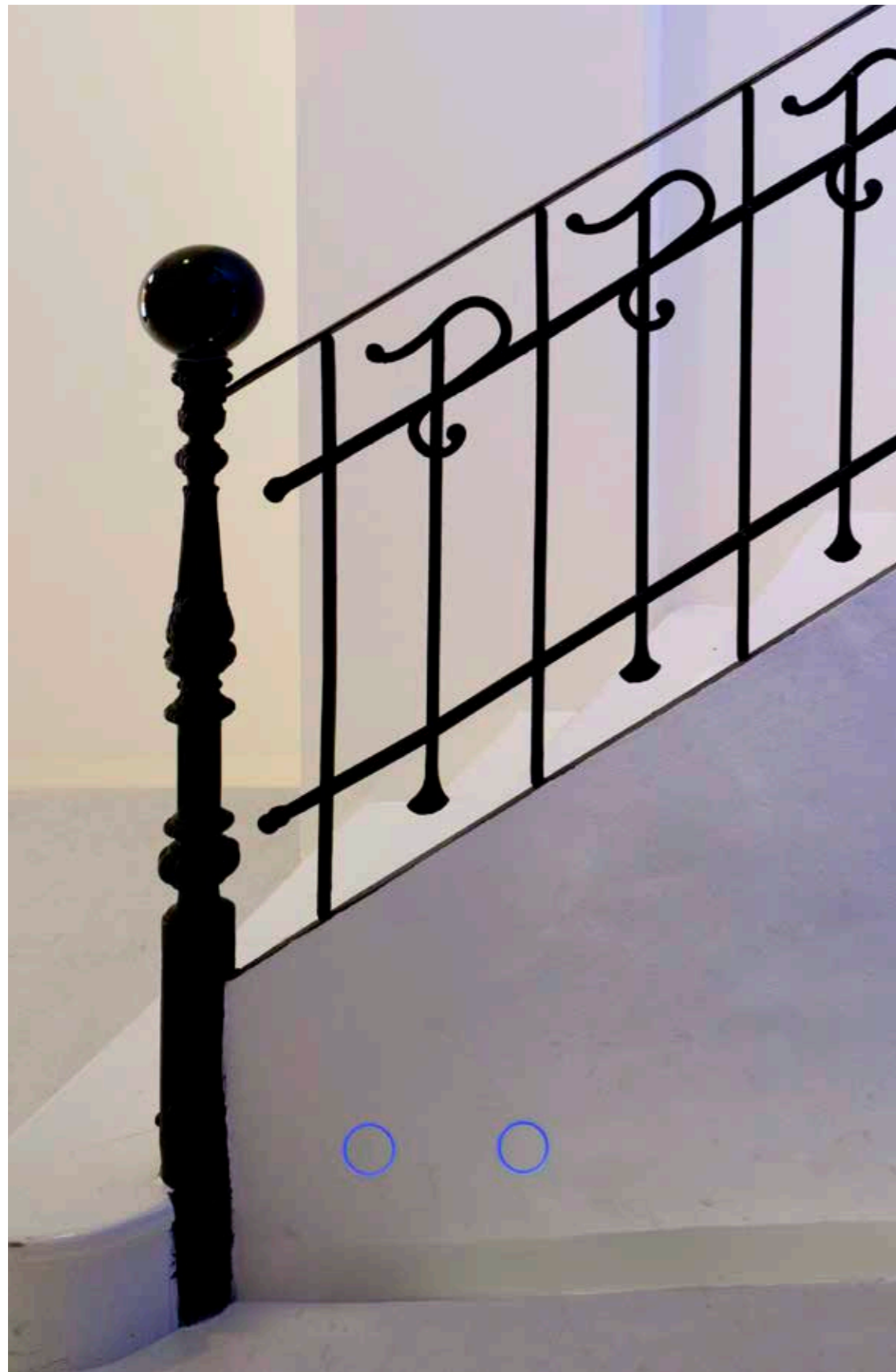

G-O IN



TOP LED
1,2W

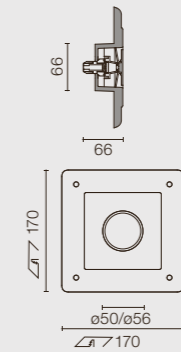

Perimetrales Licht
Lighting Colours

Weiss
White

Amber
Amber

Blau
Blue





reddot design award
winner 2013

Lampe mit minimalem visual Impact zum Einbau auf Ebene der Gipsplattenwandverkleidung. Erhältlich mit direkt an das Netz angeschlossenen Halogen-Lichtquellen, Leuchtstofflampen und LED. Alle Versionen sind mit Opal-Sicherheitsglas ausgestattet.

SOFT SPUN

Lamp designed for minimal visual impact that is flush mounted to plasterboard walls. Available with halogen light sources connected directly to mains, fluorescent and LED lights sources. All of them include opal safety glass.

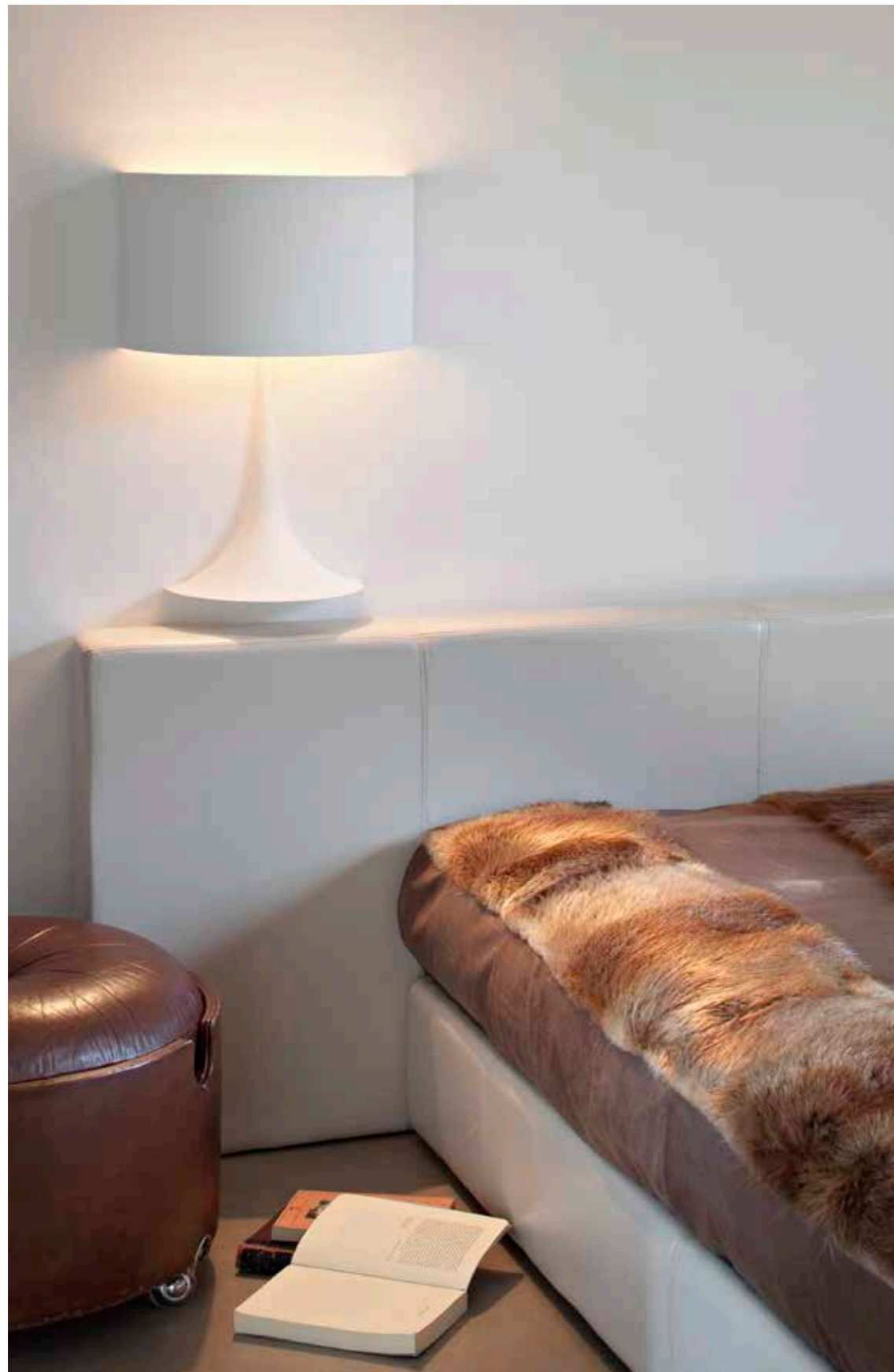



670

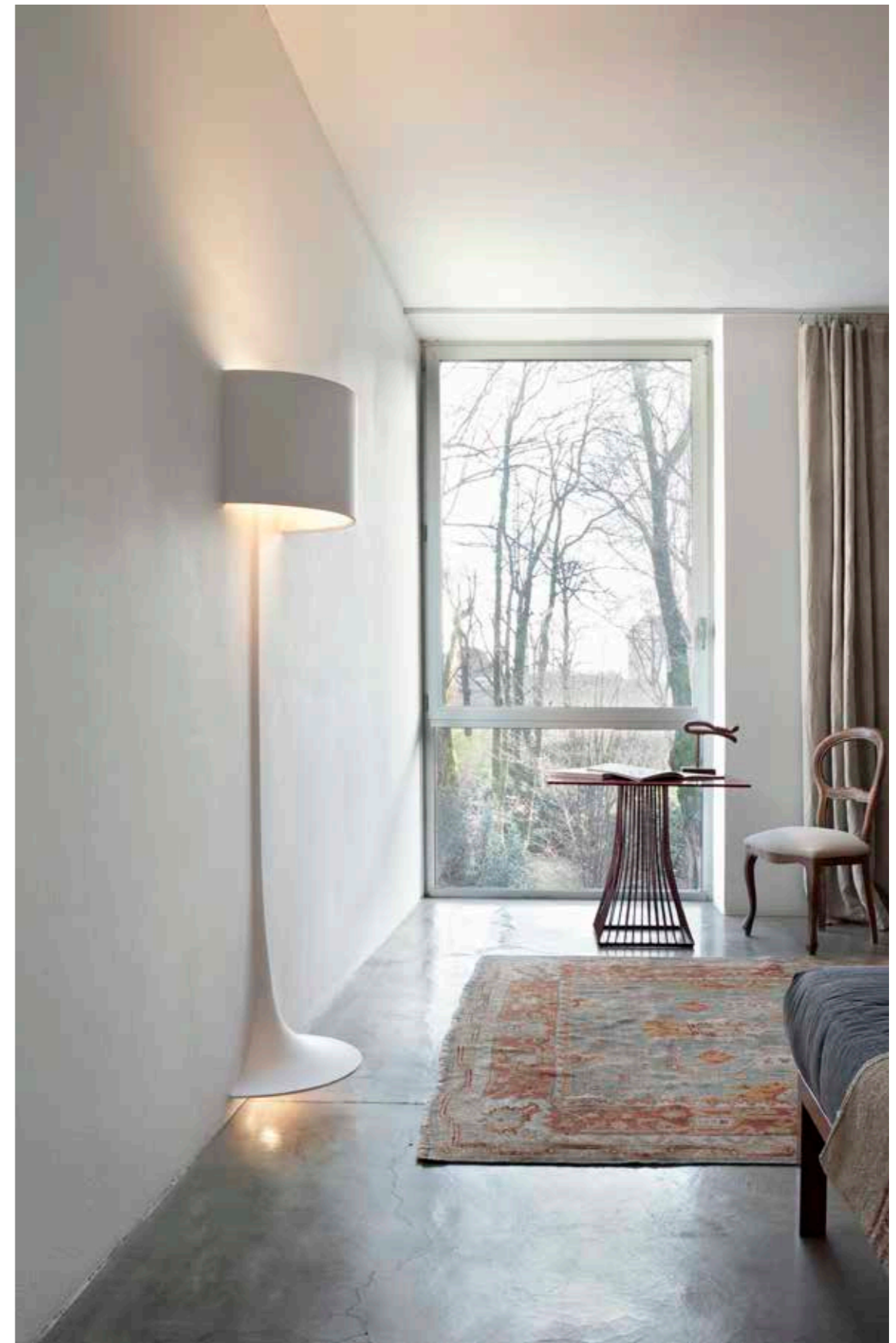

671

SOFT SPUN SMALL
HALOGEN



QT-DE-12
max 120W

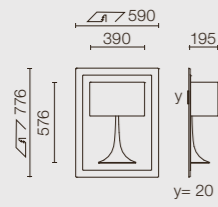

SOFT SPUN SMALL
FLUORESCENT



TC-L
18W

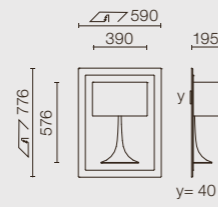

SOFT SPUN SMALL
LED



LED WHITE
35W

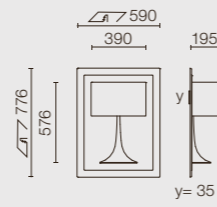

SOFT SPUN LARGE
HALOGEN



QT-DE-12
160W (diffuser) LED WHITE
1,4W

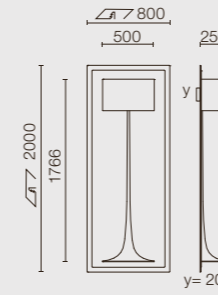

SOFT SPUN LARGE
FLUORESCENT



TC-L
24W (diffuser) LED WHITE
1,4W

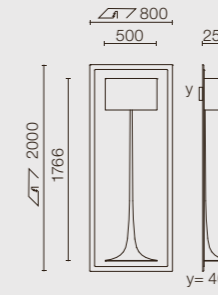

SOFT SPUN LARGE
LED



LED WHITE
35W LED WHITE
1,4W

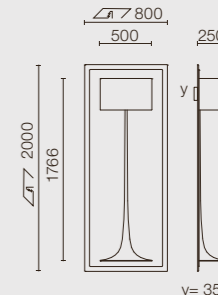

Lampe mit minimalem visual Impact zum Einbau auf Ebene der Gipsplattenwandverkleidung. Erhältlich mit direkt an das Netz angeschlossenen Halogen-Lichtquellen, Leuchtstofflampen und LED. Alle Versionen sind mit Opal-Sicherheitsglas ausgestattet.

ABAJOURD'HUI

Lamp designed for minimal visual impact that is flush mounted to plasterboard walls. Available with halogen light sources connected directly to mains, fluorescent and LED lights sources. All of them include opal safety glass.



676

677



ABAJOURD'HUI SMALL



QT-32
max 75W

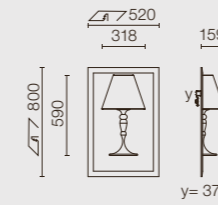

ABAJOURD'HUI LARGE



QT-32
max 150W

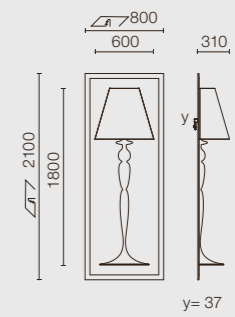

Rundes Downlight in verschiedenen Durchmessern für minimalen visual Impact auf Gipsverkleidungen. Für hohen Sehkomfort wird die Lichtquelle in einer tiefen Position installiert. Deckeninstallation für Decken aus Gipsplatten.

TEARDROP

Round downlight available in several diameters designed for minimal visual impact made of plaster. The light source is installed in a deep position, to achieve high visual comfort. Plasterboard ceiling-mounting.







TEARDROP SMALL

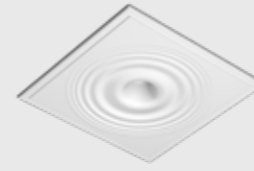

QR-CBC-51
max 50W

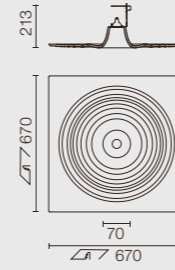

TEARDROP MEDIUM

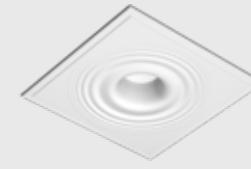

TC-DEL
26W

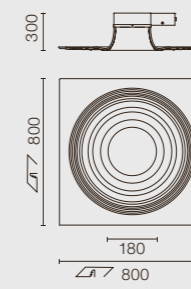

TEARDROP LARGE

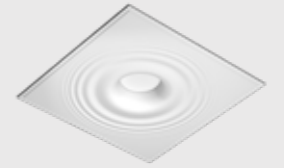

TC-L
18W

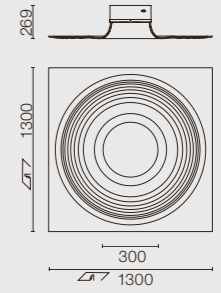

Die Beleuchtungsgruppe USL Pluto umfasst ein Hängeleuchten-Set aus Soft Composite für Innenräume. Bietet vielseitige Einsatzmöglichkeiten, weil das Produkt je nach Modell mit Lichtquellen sowohl für Allgemeinbeleuchtung als auch für Akzentbeleuchtung ausgestattet werden kann.

USL

The USL Pluto luminous group encompasses a series of suspended luminaires for indoor use, made of Soft Composite. It offers great versatility as, depending on models, they can incorporate both ambient light sources and accent light sources.





USL 100 PLUTO



T5 FH
14W

T5 FQ
24W

COLD CATHODE
90W
3x30W

LED WHITE
45,5W
13x3,5W

LED RGB
22,75W
13x1,75W

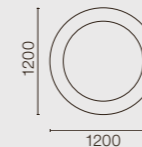

USL 200 PLUTO



T5 FH
21W

T5 FQ
39W

COLD CATHODE
161W
4x40W

LED WHITE
84W
12x7W

LED RGB
42W
12x3,5W

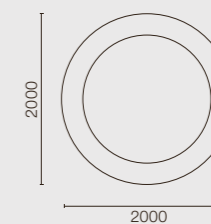
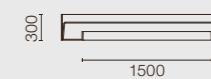



SOFT ARCHITECTURE: IN

Einbauleuchte für die Wand- und Deckenmontage in Innenräumen. Erhältlich in den Versionen rund/quadratisch/rechteckig. Das Design gewährleistet eine Einbindung in die Umgebung bei minimalem visual Impact. Die Produktfamilie Round, Square & Vertical Light ist mit einem Innenschirm sowie einer Diffusionslinse aus Polycarbonat ausgestattet.

ROUND, SQUARE & VERTICAL LIGHT

Recessed light fitting for interior wall and ceiling mounting. Available in round/square/rectangular versions. Designed to blend in with the surroundings and generate minimal visual impact, the Round, Square & Vertical Light family incorporates a screen on the inside as well as diffuser polycarbonate lens.

DESIGNED BY FLOS SOFT ARCHITECTURE

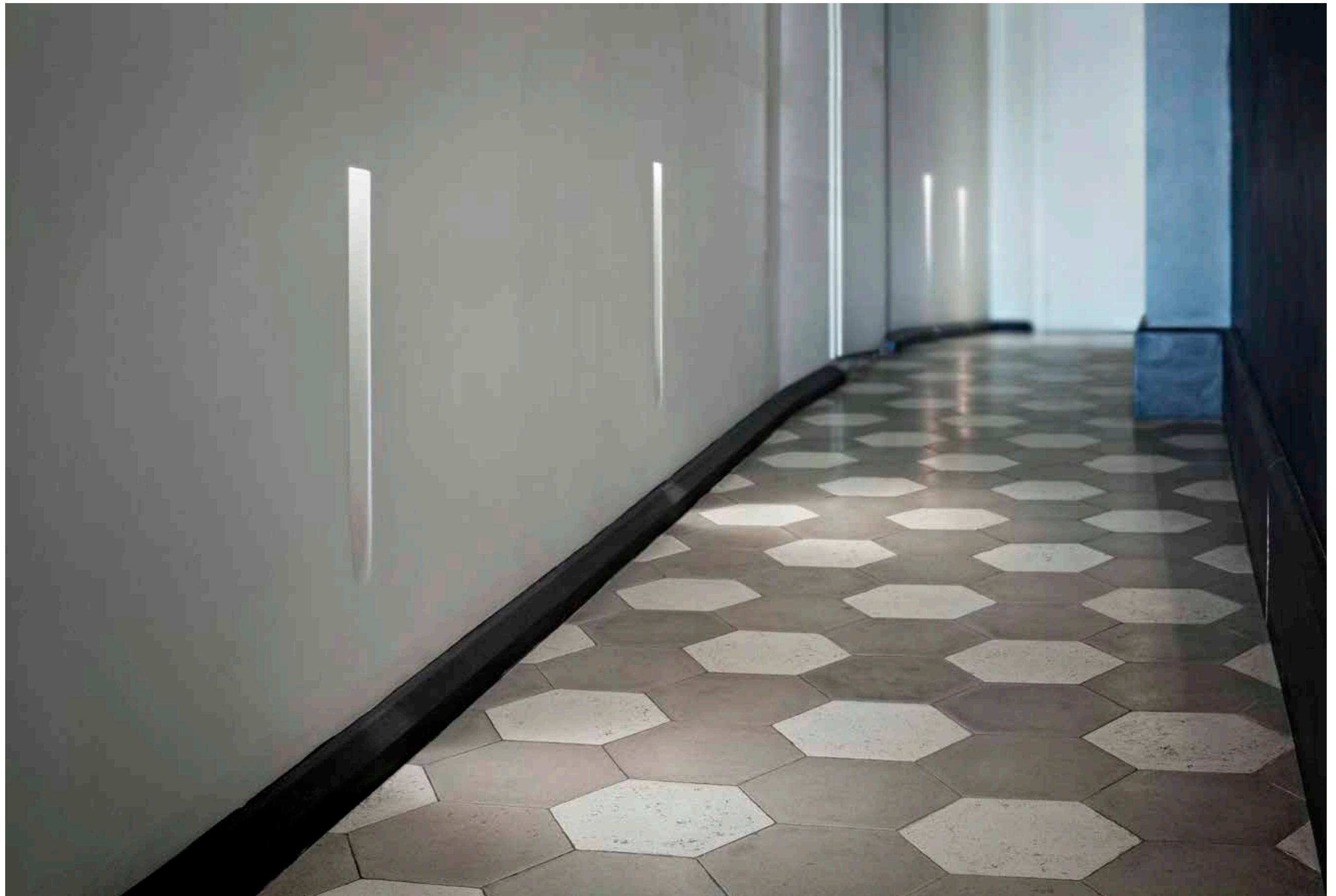

IN / SQUARE LIGHT

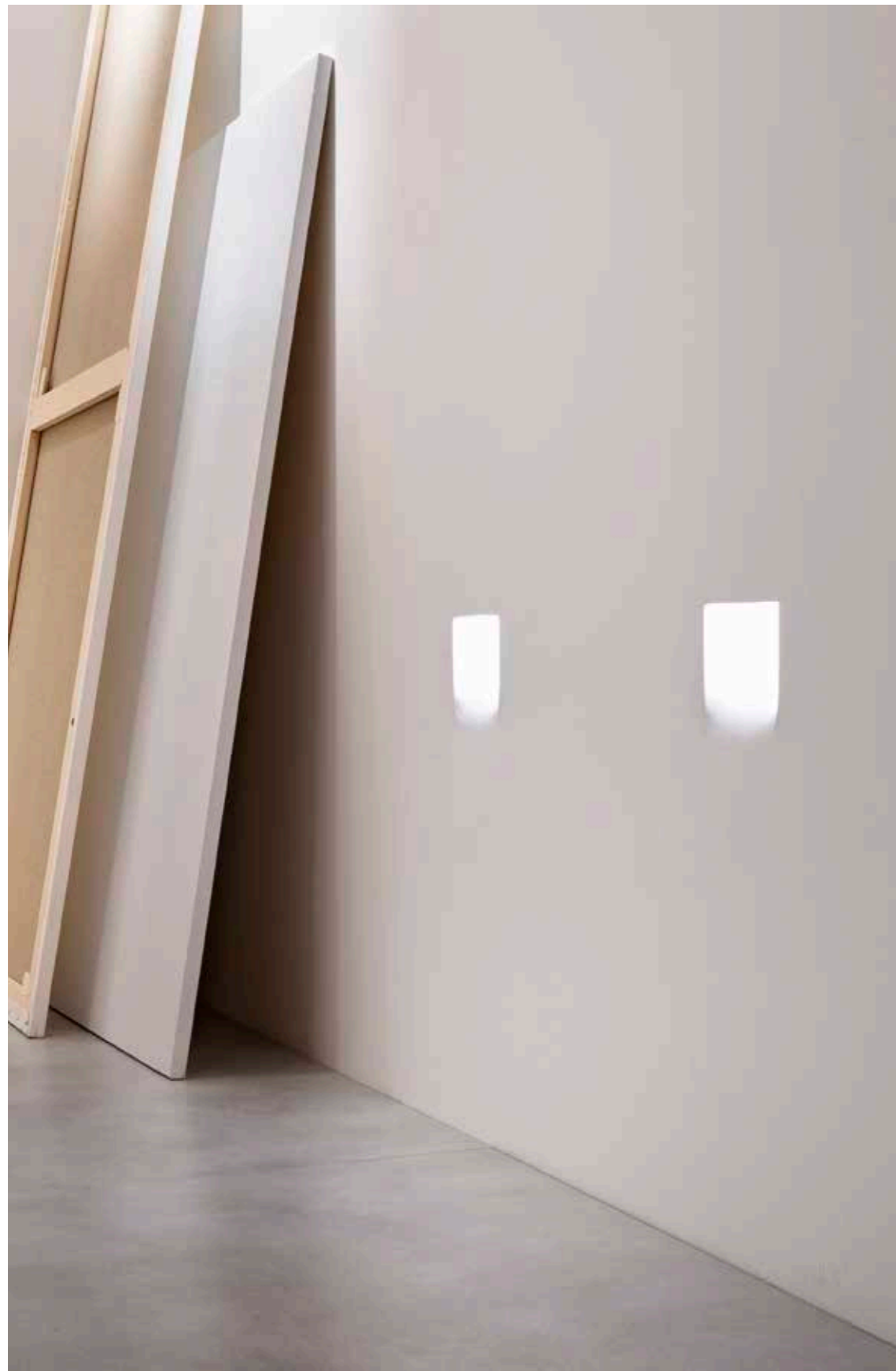

696

IN / ROUND LIGHT

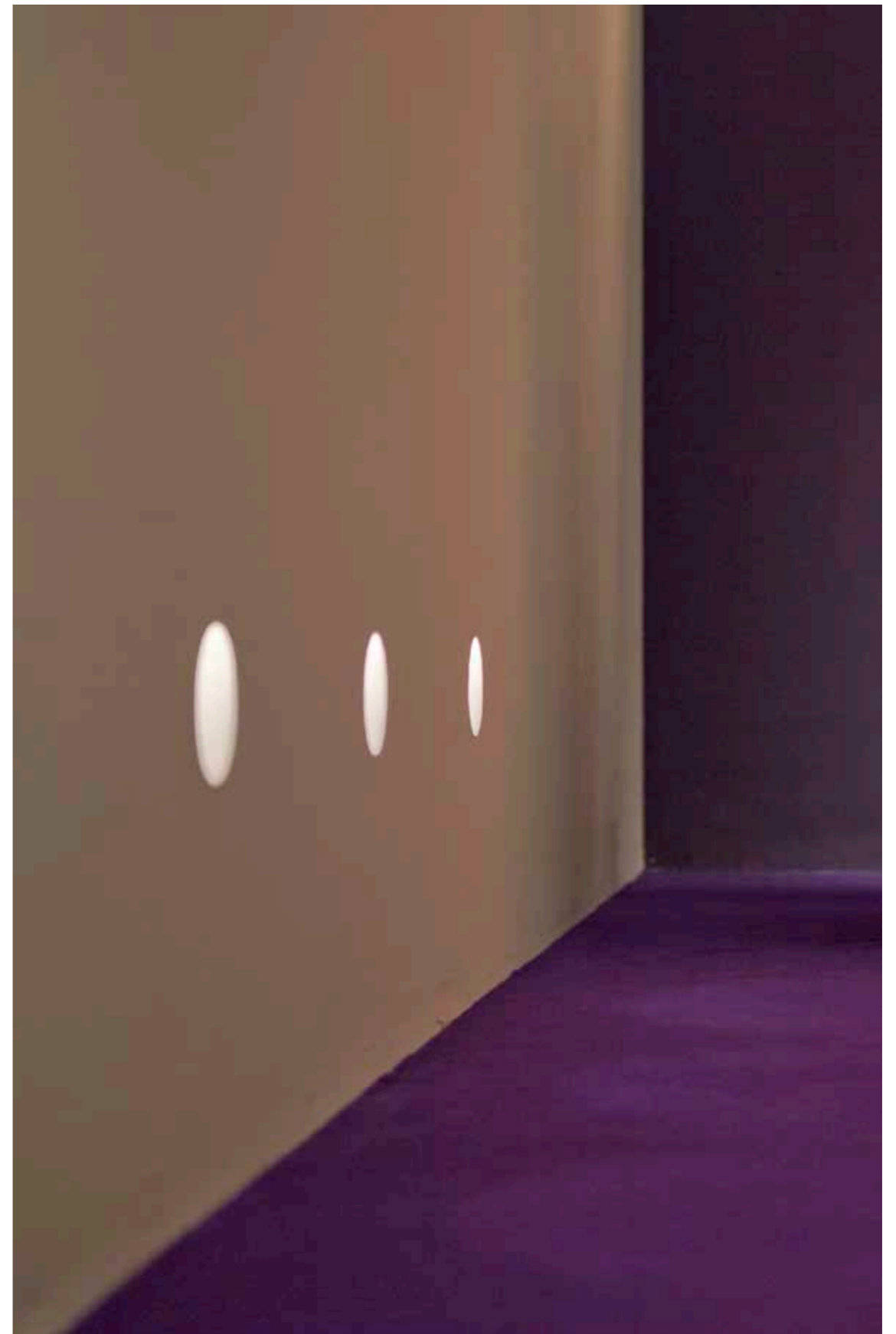

697

ROUND LIGHT SMALL



LED WHITE
1W

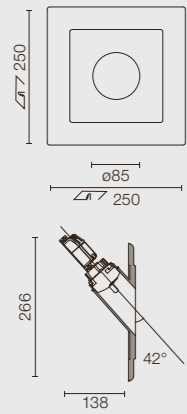

ROUND LIGHT MEDIUM



LED WHITE
7W

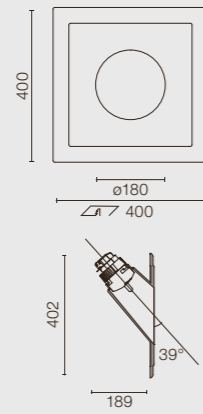

ROUND LIGHT LARGE



LED WHITE
7W

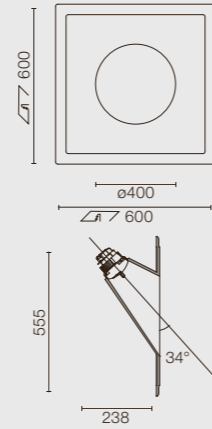

SQUARE LIGHT SMALL



LED WHITE
1W

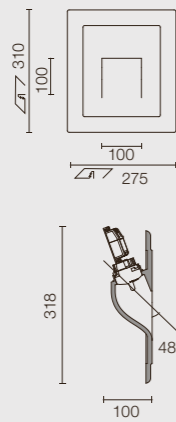

SQUARE LIGHT LARGE



LED WHITE
7W

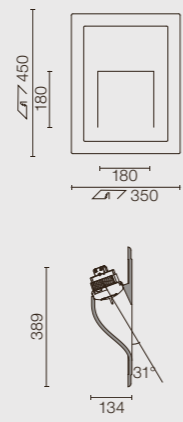

VERTICAL LIGHT SMALL



LED WHITE
1W

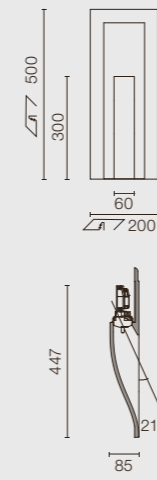

VERTICAL LIGHT LARGE



LED WHITE
7W

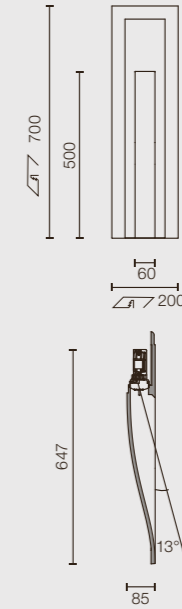

SOFT ARCHITECTURE: IN

Downlight Einbauleuchtenprogramm für minimalen visual Impact. Erhältlich in runder und quadratischer Form bietet USB Round & Square zudem Versionen mit einem oder zwei Lichtpunkten sowie die Version Wall-Washer.

USB ROUND & SQUARE LIGHT

Programme of recessed downlight luminaires for minimal visual impact. Apart from being available in round and square versions, USB Round & Square is in one and two light versions and in wall-washer version.

DESIGNED BY FLOS SOFT ARCHITECTURE

USB ROUND 1L



USB ROUND 1L W-W



QR-CBC-51
max 50W

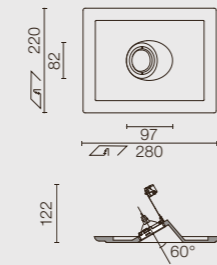
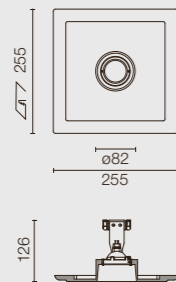

USB ROUND 2L



USB ROUND 2L W-W



QR-CBC-51
max 50W

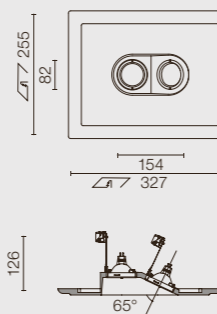
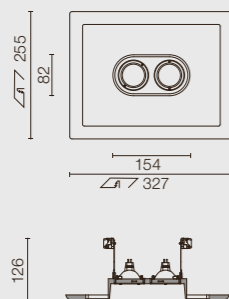

USB SQUARE 1L



USB SQUARE 1L W-W



QR-CBC-51
max 50W

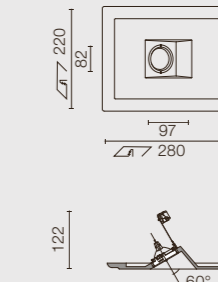
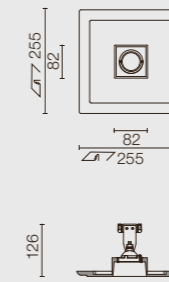

USB SQUARE 2L



USB SQUARE 2L W-W



QR-CBC-51
max 50W

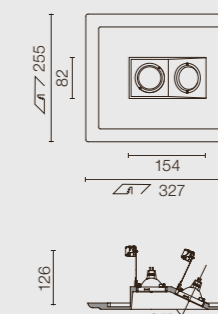
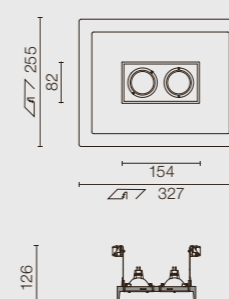

Produktfamilie von Leuchten, die sich dank Soft Composite Technologie perfekt in den Architekturraum einfügen. Es sind drei Versionen erhältlich: Die Version Smooth zeichnet sich durch das glatte Profil aus, die Version Starck durch das Profil, das an der Lampe Long an & d Hard inspiriert ist, und die Version Wanders durch das Profil, das an der Lampe Sky Gardens inspiriert ist. Die drei Versionen können sowohl an der Decke als auch der Wand installiert werden und verfügen über LED-Technologie jüngster Generation in der Farbe warmes Weiß oder RGB.

SOFTPROFILE

Family of luminaires that use Soft Composite technology to become perfectly integrated into the architectural space. There are three versions: the Smooth version characterised by its plain profile, the Starck version whose profile is inspired by the Long & Hard lamp, and the Wanders version with profile inspired by the Sky Garden lamp. The three versions can be ceiling and wall mounted, and they have latest generation LED technology in warm white colour or RGB.



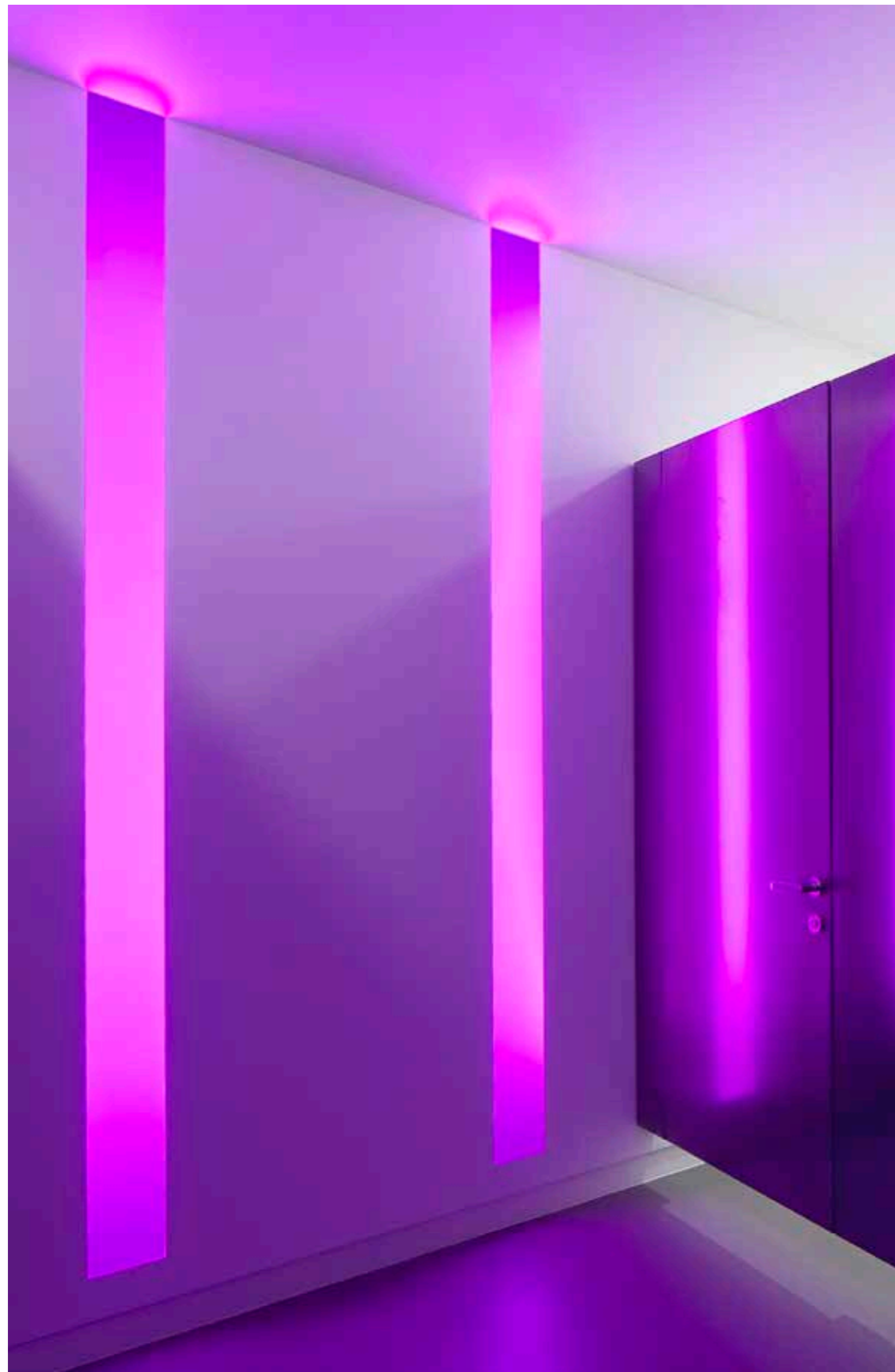

708



709

SOFTPROFILE SMOOTH
SMALL



SOFTPROFILE SMOOTH
LARGE



SOFTPROFILE DECO WANDERS
SMALL

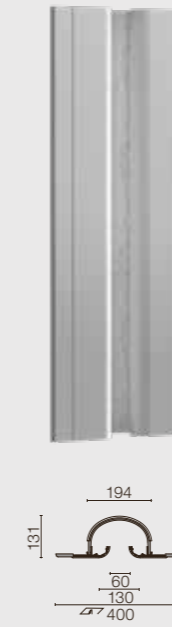

SOFTPROFILE DECO WANDERS
LARGE

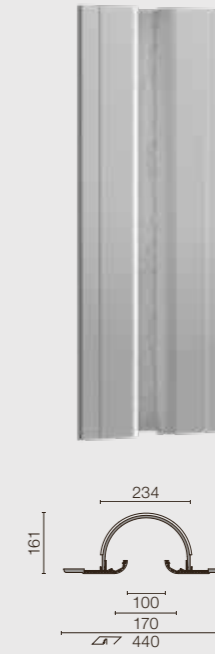

SOFTPROFILE DECO STARCK
SMALL



SOFTPROFILE DECO STARCK
LARGE



Beleuchtungssystem für direkte Allgemeinbeleuchtung. Die Soft Composite Module für die Deckenmontage nehmen die Leuchtstoffmodule auf, die für gleichmäßige Beleuchtung ohne Schattenbildung sorgen. Inspiriert an der Leuchte Kap von FLOS architectural kann die Innenseite von Kappprofile gestrichen werden, um verschiedene Dekors ermöglichen.

KAPPROFILE

General direct light lighting system. Comprised of Soft Composite modules that permit ceiling mounting and which house fluorescent lighting modules, thus guaranteeing uniform, shadow-free lighting. Inspired by the FLOS architectural Kap luminaire. The inside of the Kappprofile can be painted, offering different décors.

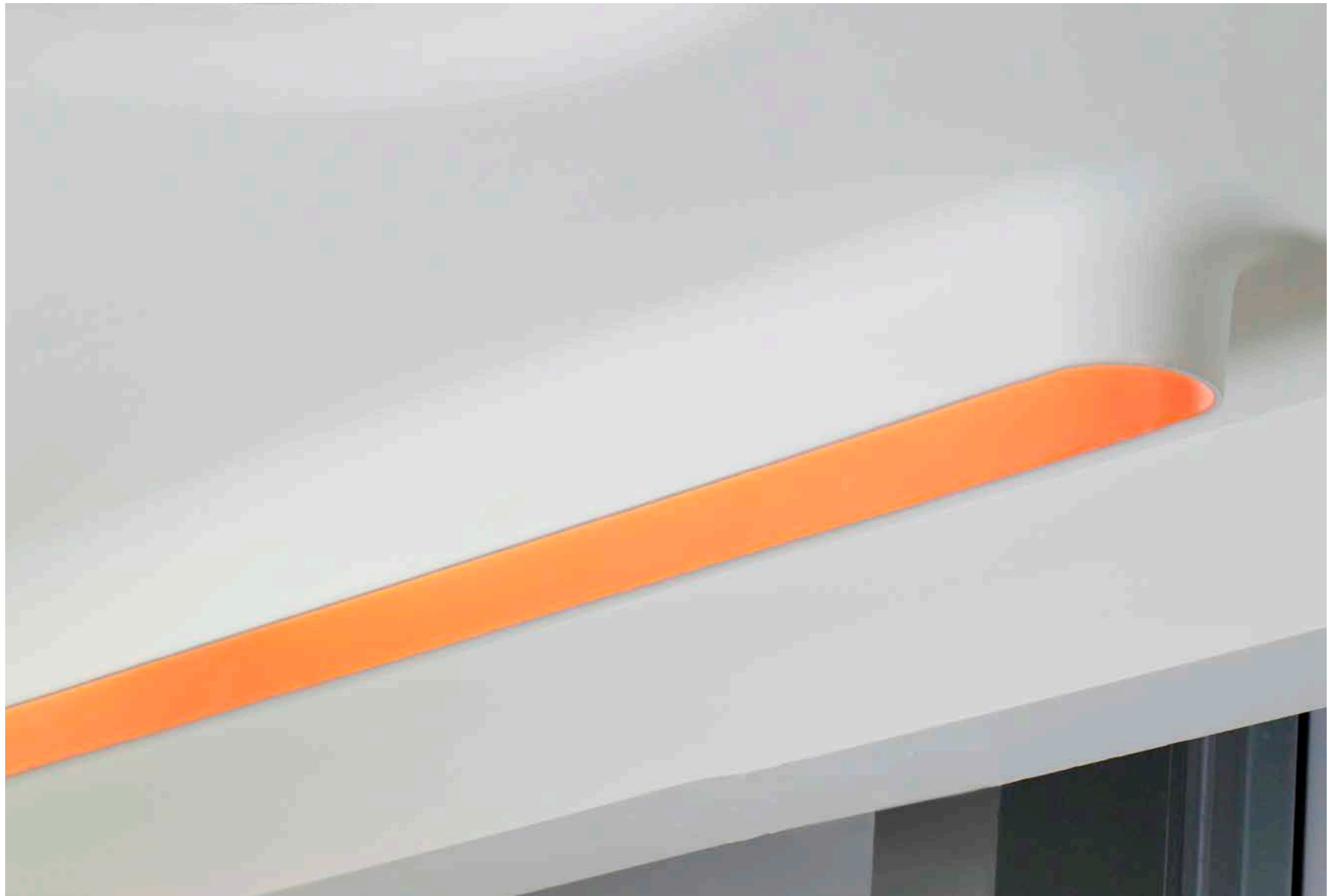



KAPPROFILE

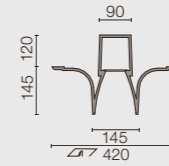
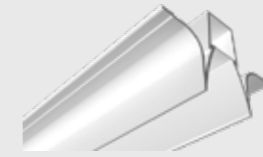

LightLight® In System Profile ist ein Beleuchtungssystem, das eigens konzipiert wurde, um alle LightLight® Produkte von FLOS architectural aufzunehmen. Dank Soft Composite Technologie fügt sich dieses Produkt perfekt in das Umfeld ein und minimiert den visual Impact. Erhältlich in den Versionen Surface, Flushed und Wall-Washer.

LIGHTLIGHT® IN SYSTEM PROFILE

LightLight® In System Profile is a lighting system that is especially designed to house all the FLOS architectural LightLight® products. Thanks to the Soft Composite technology, this product integrates perfectly into the environment, minimising visual impact. It is available in Surface, Flushed and Wall-Washer versions.



LIGHTLIGHT® IN SYSTEM
PROFILE SURFACE

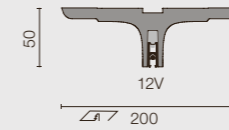

LIGHTLIGHT® IN SYSTEM
PROFILE FLUSHED

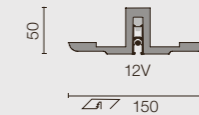

LIGHTLIGHT® IN SYSTEM
PROFILE W-W

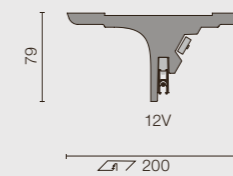

Usl Out ist eine mit Soft Composite Technologie gefertigte Leuchte in Konusform. Da das Design die Installation verschiedenster Strahlertypen von FLOS architectural ermöglicht, bietet Usl Out Lösungen sowohl für die Allgemein- als auch für die Akzentbeleuchtung.

USL OUT

Usl Out is a luminaire made with Soft Composite technology and tapered shape. As it is designed to install different types of FLOS architectural spotlights, Usl Out offers solutions for both ambient and accent lighting.



USL 6031

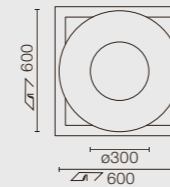
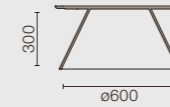

USL 6031
RECESSED

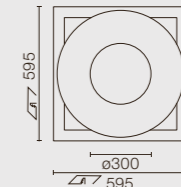
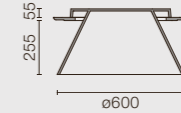

USL 6060
FOR MODULAR CEILING

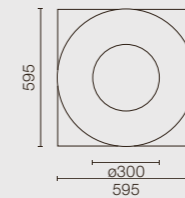
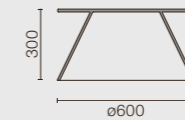

Mit Usl 900 Disk bietet FLOS eine Lösung für die Allgemeinbeleuchtung dank Soft Composite Technologie. Als Lichtquelle stehen zur Auswahl Leuchtstoff- und Kaltkathodenlampen sowie weißes LED und RGB LED.

USL 900 DISK

With the Usl 900 Disk, FLOS offers a solution for ambient lighting, using Soft Composite technology. Existent with fluorescent, cold cathode, white LED and RGB LED light source.





USL 900 DISK ON



T5 FH
14W

T5 FQ
24W

COLD CATHODE
I: 90W (3x30W)
E: 120W (4x30W)

LED WHITE
I: 45,5W (13x3,5W)
E: 63W (18x3,5W)

LED RGB
I: 22,75W (13x1,75W)
E: 31,5W (18x1,75W)

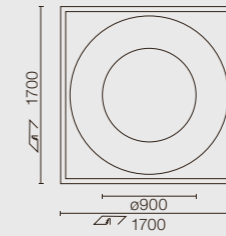
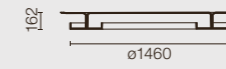

I: internal
E: external

DISTRIBUTION

BELGIUM AND LUXEMBOURG

Flos Belux
M +32 474 413 485
Fax +39 0302438 250
flosbelux@flos.com

UNITED KINGDOM

Atrium Ltd.
28 Leonard Street
EC2A 4BY London
Tel +44 (0) 20 7681 9933
Fax +44 (0) 20 7681 9943
flos@atrium.ltd.uk

NORWAY

Drammensveien 120
0277 Oslo - Norway
Tel +47 (0) 2212 86 00
Fax +47 (0) 2212 86 08
info@flos.no

JAPAN

Flos Co., Ltd.
PMC Building 9F
1-23-5 Higashiazabu Minato-Ku
Tokyo 104-0044
Tel +81 (0) 3 35 82 14 68
Fax +81 (0) 3 35 82 09 74
info@flosjapan.com

INDIA

Flos Representative Office
1, Commonwealth Lane #08-12
149544 Singapore
Tel +65 (0) 6372 1495
Fax +65 (0) 6372 7607
flosindia@flos.com

FRANCE

Flos Projets
20-22, passage Dauphine
75006 Paris
Tel +33 (0) 140 64 17 44
flos.projets@flos.com

UNITED KINGDOM

International Projects UK Division
Tel +44 (0) 7771 871969
flos.international@flos.com

THE NETHERLANDS

Flos BV
Cruquiusweg 109Q
1019 AG Amsterdam
Tel +31 (0) 20 560 50 60
Fax +31 (0) 20 560 50 70
flosnetherlands@flos.com

ASIA PACIFIC

Flos Representative Office 1,
Commonwealth Lane #08-12
149544 Singapore
Tel +65 (0) 6372 1495
Fax +65 (0) 6372 7607
flosasia@flos.com

LATIN AMERICA

Flos LatAm
M +52 1 55 3020 3867
flos.latinoamerica@flos.com

U. S. A.

Flos USA Inc.
110 York Street - 5th Floor
Brooklyn, NY 11201
Tel +1 (718) 875-3472
Fax +1 (718) 875-3473
info@flosusa.com

AUSTRIA - GERMANY SWITZERLAND

Flos GmbH
Hausinger Strasse 4
40764 Langenfeld
Tel +49 2173 10937-20
Fax +49 2173 10936-65
info@flos-gmbh.de

DENMARK

Flos Scandinavia A/S
Sydhavnsgade 28
DK-2450 København SV
Tel +45 (0) 3388 60 00
Fax +45 (0) 3388 60 10
info@flos.dk

SWEDEN

Flos Scandinavia A/S
Karlplan Lützengatan 1 - S-115-20
Tel +46 (0) 8 660 4405
Fax +46 (0) 8 660 7005
info@flos.se

CHINA

Flos Illumination Co. Ltd.
Unit 101, Floor 1,
building B9 No. 800 of Chang De road
Jing An District Shanghai
200040 China
Tel 86 021 62176187
Hr.china@flos.com

MIDDLE EAST

Flos Representative Office
Office # 702A
Sama Tower
Sheikh Zayed Road
Dubai, United Arab Emirates
Tel +97143888803

SHOWROOMS

MILANO

Corso Monforte, 15
20122 Milano
Tel +39 02 79 84 57
Fax +39 02 89 78 56 41
contract.milano@flos.com

OSLO

Drammensveien 120
0277 Oslo - Norway
Tel +47 (0) 2212 86 00
Fax +47 (0) 2212 86 08
info@flos.no

COPENAGHEN

Sydhavnsgade 28
DK-2450 København SV
Tel +45 (0) 3388 60 00
Fax +45 (0) 3388 60 10
info@flos.dk

TOKYO

PMC Building 9F
1-23-5 Higashiazabu Minato-Ku
Tokyo 104-0044
Tel +81 (0) 3 35 82 14 68
Fax +81 (0) 3 55 75 70 87
info@flosjapan.com

STOCKHOLM

Karlplan Lützengatan 1 - S-115-20
Tel +46 (0) 8 660 4405
Fax +46 (0) 8 660 7005
info@flos.se

AMSTERDAM

Cruquiusweg 109Q
1019 AG Amsterdam
The Netherlands
Tel +31 (0) 20 560 50 60
Fax +31 (0) 20 560 50 70
info@flosmail.nl

PARIS

Flos Projets
20-22, passage Dauphine
75006 Paris
Tel +33 (0) 140 64 17 44
flos.projets@flos.com

FLAGSHIP STORES

MILANO

Corso Monforte, 9 - 20122
Tel +39 02 37011080
Fax +39 02 780833
flosmilano@flos.com

ROMA

Via del Babuino, 85 - 00187
Tel +39 06 3207631
Fax +39 06 3207690
flosroma@flos.com

PARIS

15, rue de Bourgogne - 75007
Tel +33 (0) 1 53 85 49 93
Fax +33 (0) 1 53 85 49 99
shop@flos.fr

LYON

17 rue Jarente - 69002
Tel +33 478621301
Fax +33 478622119
lyon@flos.fr

HONG KONG

G/F Wyndham Place, 44 Wyndham
Street, Central
Tel +852 2801 7608
Fax +852 2869 0722
dentropo@netvigator.com

STOCKHOLM

Karlplan Lützengatan 1 - S-115-20
Tel +46 (0) 8 660 4405
Fax +46 (0) 8 660 7005
info@flos.se

NEW YORK

152 Greene Street - NY 10012
Tel +1 212 941 4760
Fax +1 212 941 4763
info@flosusa.com

CONTACT

ITALY

Flos Spa
Via Angelo Faini, 2
25073 Bovezzo (Brescia)
Tel +39 0302438.1
Fax +39 0302438.250
info@flos.com

SPAIN

Antares Iluminación S.A.U.
Calle Mallorca, 1
Polígono Industrial Reva
46394 Ribarroja (Valencia)
Tel +34 96 166 95 20
Fax +34 96 166 82 86
flos.architectural@flos.com

CREDITS

ART DIRECTION

Apartamento Studios

ART PHOTOGRAPHY

Carl Kleiner

PHOTO INTEGRATION

Mozing Studio
Jorge Herrera Studio

PHOTO PRODUCT

Piero Fasanotto
Javier Ferrer
Carlos Gutiérrez
Alessandro Lourenço

LAYOUT

Flos Architectural Team

GRAPHIC DESIGN

Apartamento Studios

ILLUSTRATIONS

Aurore de La Morinerie

COMIC

Flag

EDITION

April 2018
Copyright © Flos 2018
All rights reserved

PRINTED BY

Litopat Verona Italy

ACKNOWLEDGEMENTS

Anarchitect
Andreu World
Archiproducts
Axiom Consulting Partners
Barbara Balestreri
Bombas Gens
Budapest
Carhartt
Central European University
Cosín Showroom
De Witte Duif
Emilio Nanni
Familia Parrón-Ortiz
Fran Silvestre
Gandía Blasco
Gyro Toys
Hakei
Iñigo Beguiristain
Itínere Baqueira
Kitoko
Lardini
Lightpoint
Moba Showroom
Molteni
Moremas Arquitectos
Mount Sinai Hospital
Negre Estudio
O'Donnell + Tuomey Ltd.,
Palazzo Reale Milano
Pepe Cabrera
Piaggio Fast Forward
Pitsou Kedem
RF Dubai
RNB
Rossano Ferretti
Teampannon Kft
The KaDeWe Group
Val Office
Vicarbe
Zusa

IN-PLACE PHOTOGRAPHY

Adrian Houston
Aleš Jungmann
Anarchitect I
Andrew Krucko
Andrew Latreille
Andy Spain
Andy Stagg
Angel Rosique Photography
B2Ai – fotograaf Bart Heijns
Bernard Andre
BIS images
Boys Plays Nice
C. Taylor Crothers (CTC)
Celine de Gussem
Cesare Chimenti
Chiel de Nooyer
David Frutos
Diana Di Nitto

EK Yap Creative & Photography
Eugeni Pons
Fernando Alda
Fraser Marsden
Germano Borrelli
Gionata Xerra
Héctor Santos
Jabali Studio
Javier Orive
Jesús Granada
Joao Morgado
Julian Walter
Killian O'Sullivan
LevaSaudargaite
Liesbeth Goudenhooff
Lindman Photography AB
Matt Chisnall
MaxRommel

MCM and The Estee Lauder Companies
UK & Ireland
Moriq interiors and Design Consultants
Olivier Baco
PIAGGIO Fast Forward
RBA ImagesBIS images
Roland Halbe
Santi Caleca
Schwarz – Licht
Shuhe
Simona Rota
Studio Moost / Studio Tomorrow
Tamas Bujnovszky / BE LIGHT!
Tommaso Sartori
Valerie Clarysse / Beelpunt
Photography

As our world is in constant evolution, technical upgrades happens every day in our business.

Flos aim is to offer always the best reliable technology available, constantly reviewing our products and upgrading them as soon as technologic evolutions offers benefits for our partners and clients.

This philosophy means that our technical catalogue and product data sheets also are in constant evolution, requiring upgrades and constants reviewing.

Thus, when you need technical details and the most recent product information, please browse the product section of our Flos.com official website: it is updated daily, and there you'll find the latest product details, all available part numbers, all product documents available for immediate download.

www.flos.com

WWW.FLOS.COM

