

RE

T

AIL

Retail Catalogue
by Lumina

Daphne
Elle
Flip
Galileo
Liz
Matrix
Moove
Multi X
Naomi
Opus
Perla
Ra
Tangram
Zed
Zelig
Zeta

Index	Products	Finishes	Specifications
Daphne	11	120	128
Daphne Terra	12		
Daphne	14		
Daphinette	16		
Daphine Parete	18		
Daphine Cloe	20		
Elle	23		132
Elle1	26		
Flip	29	121	133
Galileo	33		134
Galileo Mini	36		
Liz	39	122	135
Lizzy	42		
Liz Terra	44		
Lizzy Patete	46		
Matrix	49		139
Matrix Otto P	50		
Matrix Quattro P	51		
Matrix Otto	52		
Matrix Doppia	53		
Matrix Mono	54		
Moove	57	123	142
Moove Mono	60		
Moove Doppia	61		
Multi X	63		144
Multi X Terra	66		
Naomi	69	124	145
Naomi Terra	72		
Naomi Head Parete	74		

Index	Products	Finishes	Specifications
Opus	77		148
Opus Parete	80		
Perla	83		149
Perla	84		
Perla Garden	86		
Ra	91		154
Tangram	95	125	155
Tangram Terra	98		
Zed	101		157
Zed Parete	104		
Zelig	107		158
Zelig Terra	110		
Zeta	113		159
Zeta Soffitto	116		
Zeta Parete	117		



Lumina

Since 1980 we have been designing and producing technical and decorative lamps. Lumina, founded by Tommaso Cimini (Daphine, 1975), is today managed by the sons Ettore and Andrea, who carry on the family business using the most advanced technologies. Our products are distributed worldwide and displayed in some of the most famous museums and galleries in the world. Our production is made in the Arluno plants (Greater Milano Area), supported by local skilled craftsmen. We firmly believe in craftsmanship and high quality manufacturing. Our skills and experience, together with passion for technical innovation, have been adopted throughout the manufacturing process to achieve lamps with great attention to every detail.

Opposite: Lumina factory
Above and below: Lumina building from the outside and the inside



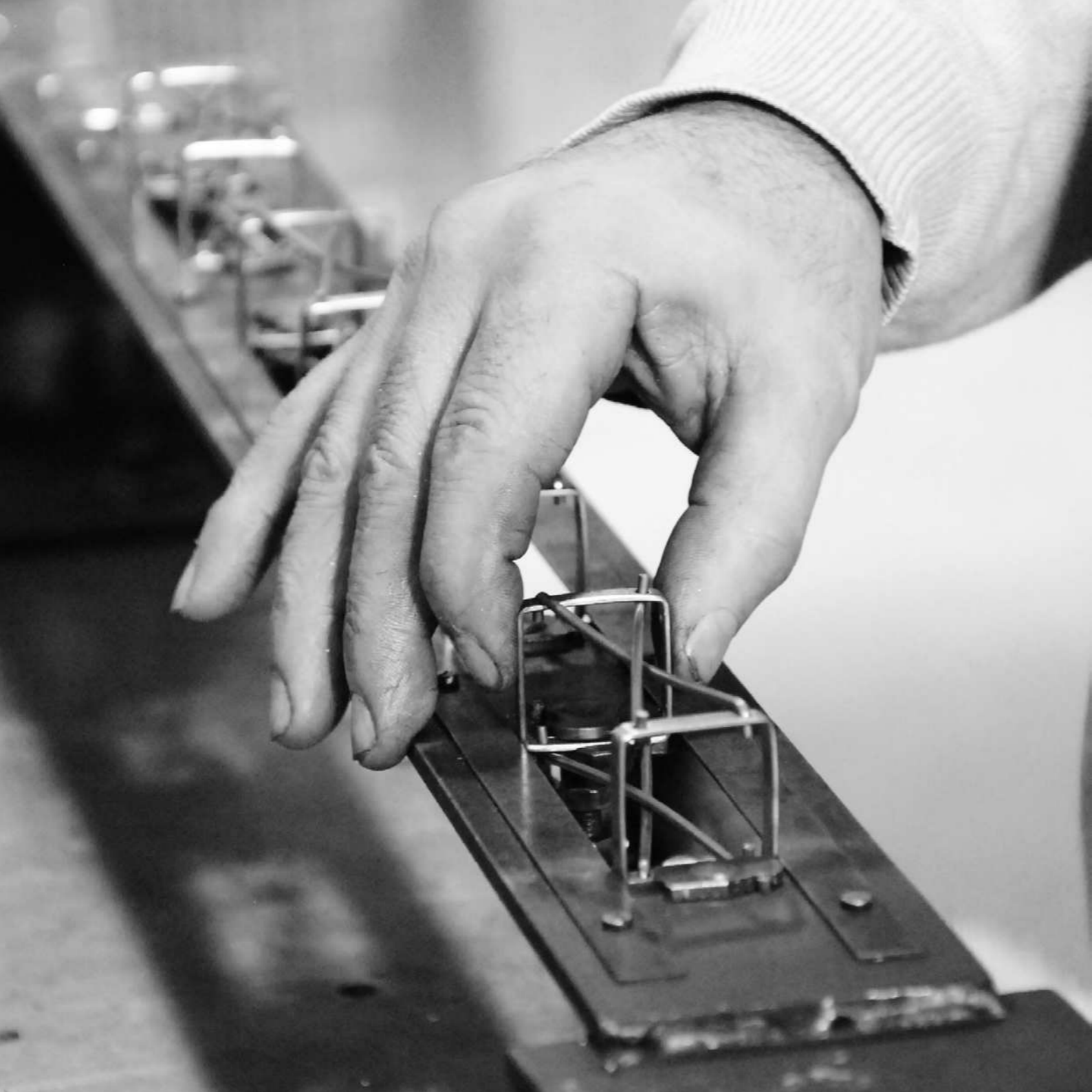

Customised production

In the last years we have been working closely with our clients, developing bespoke products for the Contract Market. Our staff's extensive experience and a short manufacturing chain make it possible for us to offer custom solutions as well as bespoke finishing on request thanks to our new integrated painting unit.

Opposite: Multi X
Above: Daphne assembly
Below: Naomi heads





The Designers

Lumina has had a long history of collaborating with various talented designers and most recently with Foster + Partners to develop unique, innovative and beautiful products.

Opposite: Ettore Cimini developing the Dot light
Right: Tommaso Cimini, founder of Lumina



Daphine
by Tommaso Cimini

Since 1975 this lamp has represented the essence of Lumina. It is displayed in some of the most famous Museums of Modern Art and Design in the World as an icon of minimalist elegance and functionality. Daphine is a timeless synthesis of function and form: an articulated arm, with a pivoting diffuser, mounted on a transformer. A GY6.35 or G4 lamp-holder for max 50W/12V halogen sources with one/double intensity switch or dimmer. Available now with LED version, identical to the Classic Daphine in shape and in movement, but with a more powerful light against lower consumptions.

Daphine
Daphine Terra
Daphinette
Daphine Parete
Daphine Cloe

Daphne Terra



Daphne Terra

Above: Daphne Classic
Below: Daphne Dimmer



Daphne



Daphne

Above: 50W halogen head
Below: 20W halogen head



Daphinette



Daphinette

Right: Daphinette base



Daphine Parete



Free rotation

Right: free rotation diffuser
The Daphine head can turn around 360° degrees.





Daphne Cloe

Cloe, part of the Daphne family, has an adjustable arm and a 360° rotating head. It has a jack connection to the base. It is characterized by a flat base with a hidden transformer inside.

Above: Jack connection
Below: clamp option for Morsetto version.



Elle
by Tommaso Cimini

A minimal yet notable floor lamp series, Elle can be used both for direct and for diffused lighting. Jointed arm, adjustable reflector and special grid for glare control are Elle's defining features. Elle is designed with an R7s lamp-holder for max 300W halogen bulbs and a dimmer on the cable for energy saving.

Elle
Elle 1

Elle



Elle

Above: safety glass
and antiglare grid
Below: articulated joint
and grip



Elle 1



Elle 1

Right: head detail



Flip
by Heinrich Wiederhold

A practical ceiling light characterized by a telescopic arm and pivoting ball joint, with metallic reflector (Ø37cm) or opaline methacrylate diffuser (Ø42cm). Available in two sizes (109/170cm and 94/140cm). Flip comes with a lamp-holder E27 for halogen and energy saving sources.

Flip



Flip

Above: coiled cable
and pivoting ball-joint
Below: extending arm



Galileo
by Emanuele Ricci

Galileo is the jewel of the Lumina collection. Galileo's precious crystal shade is the outcome of an extremely precise process of glass making. The refraction quality of the optical glass conveys the maximum possible brilliance of light through the entire shade. Available now with LED source, this new version of Galileo is even more elegant and its light even purer. Galileo comes with a lamp-holder B15d for max 100W halogen sources; Galileo Mini has a lamp-holder GY6.35 for max 50W/12V halogen sources. Galileo series is dimmable for energy saving. A decentralised mount is always included.

Galileo
Galileo Mini



Galileo Manufacturing

Above: manufacturing Galileo, first step, shaping and gluing
Below: manufacturing Galileo, final step, turning and polishing.
Galileo's precious body is handmade by master craftsmen. The thick extra-clear sheets of crystal are milled, ground, and pasted to obtain a convex lens which holds, reflects, and conducts the rays of light.

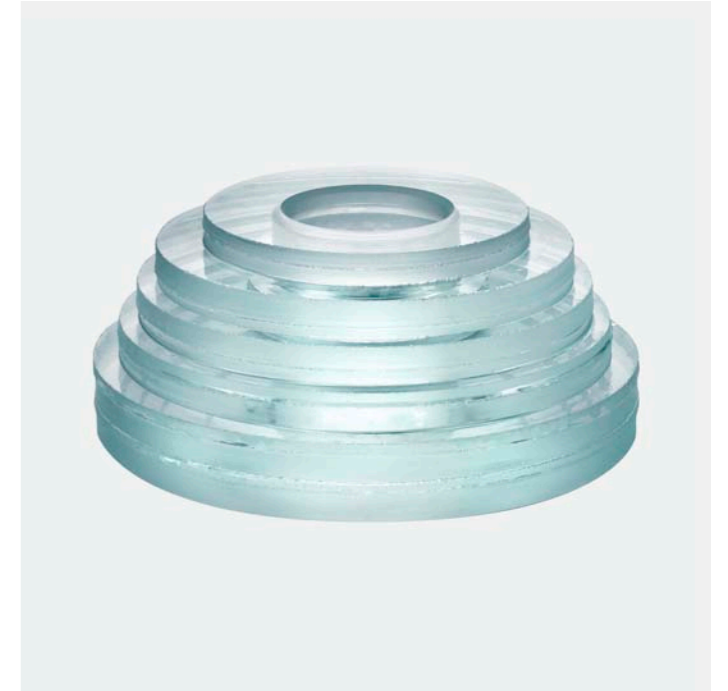



Galileo Sizes

Galileo is available in two versions: Standard (Ø20cm) and Mini (Ø12cm).

Above: Mini Ø12cm with a single lead cord
Below: Standard Ø20cm with separate cords for hanging and power

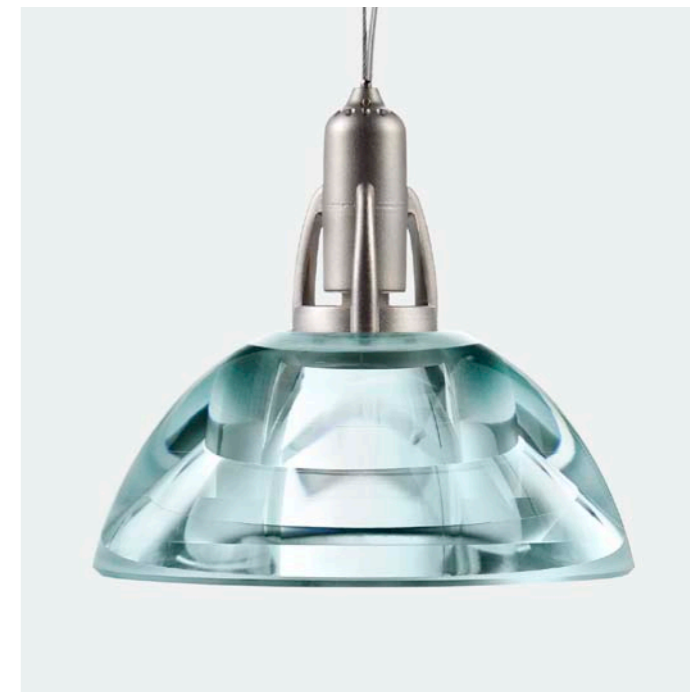
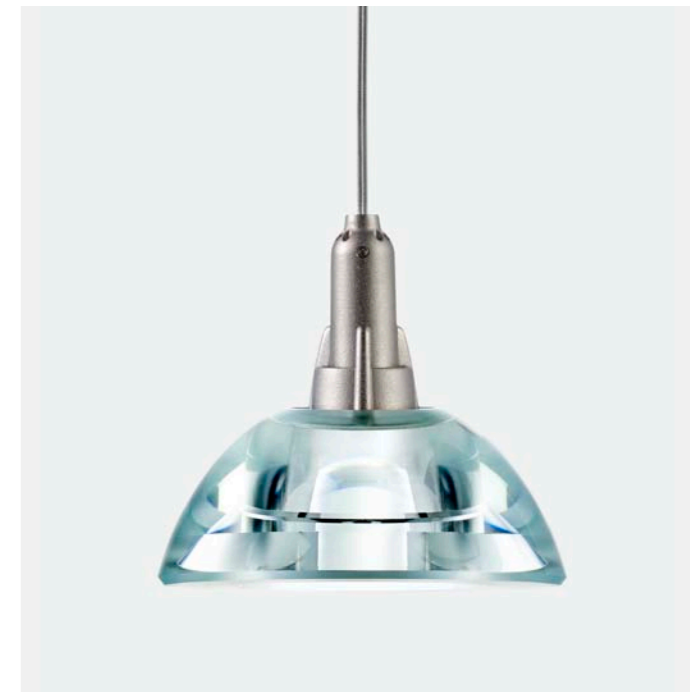

Liz
by Yaacov Kaufman

A hi-tech approach to classical lighting, Liz represents a series of lamps with an adjustable frame of flexible steel rods. All light fittings are designed for decentralized shades, conical or drum shaped, available in different colour fabrics. Liz and Lizzy for table, floor or wall come with a lamp-holder E27 for max 75/150/250W halogen sources, or energy savers. Cable-dimmer and switch. The wall fixtures are also available with an on/off switch.

Liz
Lizzy
Liz Terra
Lizzy Parete

Liz



Liz

Right: adjustable frame
and bending body



Lizzy



Lizzy

Right: shade detail



Liz Terra



Liz Terra

Right: touch sensor dimmer



Lizzy Parete



Lizzy Parete

Right: central clutch



Matrix
by Yaacov Kaufman

Kaufman's research on the friction mechanism gave birth to a wide range of light fittings with sideways adjustable arms in flexible steel rods. The Matrix series offers wall, ceiling and suspension lights, with one, four, eight or sixteen arms, with a lamp-holder E27, suitable for LED bulbs. Wall fixtures are also available with an individual switch.

Matrix Doppia
Matrix Otto
Matrix Quattro
Matrix Mono
Matrix Otto P
Matrix Quattro P

Matrix Otto P

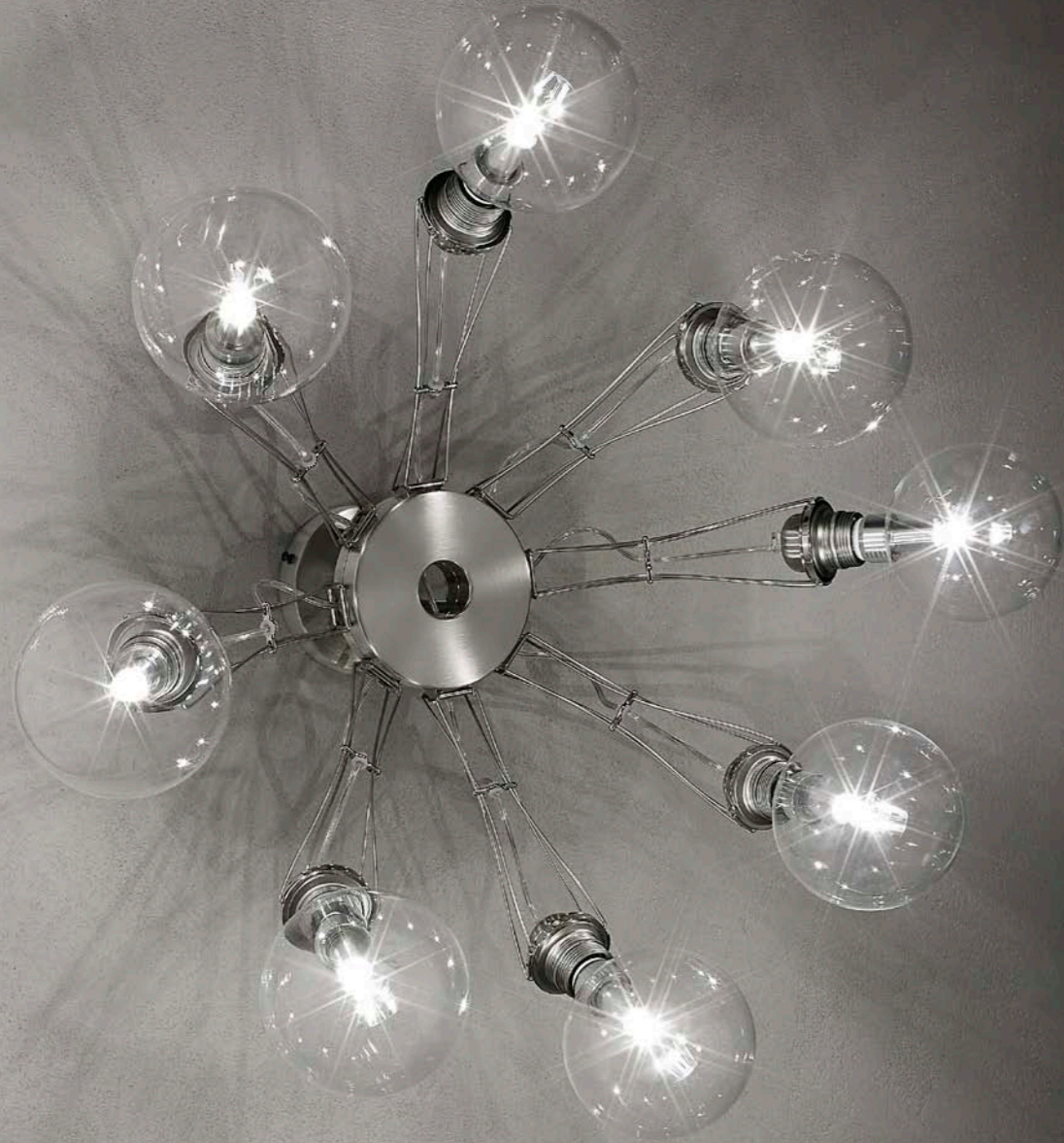

Matrix Quattro P

Right: wall fixture for
Matrix Quattro P



Matrix Otto



Matrix Doppia



Matrix Mono



Matrix Mono

Above: Switch Version
Below: socket for Matrix



Moove
by Francesco Brambilla

Moove is an innovative ceiling lamp suspended from a carbon fiber arm, which revolves 360° (Moove) or 180° (Moove Doppia), with adjustable shades (30/175cm). Available also in the Mono version. Moove shades are made of fabrics or woven metal. The light fittings all come with a lampholder E27 for halogen sources up to 150W, or energy savers.

Moove
Moove Doppia
Moove Mono

Moove



Moove

Above: Moove Doppia
pivoting canopy
Below: moving pulley



Moove Mono



Moove Doppia



Multi X
by Yaacov Kaufman

An extreme development of Yaacov Kaufman's design, Multi X's original feature is its modular frame of flexible steel rods, which are self-standing and freely adjustable in all directions. Multi X and Multi X Terra are available with halogen sources and lamp-holders G9 up to 60W, with a switch located on the body.

Multi X
Multi X Terra

Multi X



Multi X

Right: articulated lattice
of stainless steel rods



Multi X Terra



Multi X Terra

Above: adjustable diffuser
and grip



Naomi
by Yaacov Kaufman

A series of light fittings in aluminium with a 360° adjustable reflector. Available with one or two arms and designed to be matched either to its classical base or to other supports (clamp on, wall attachment, table mount). The lamp is characterised by a compact reflector and a central joint with tangential frictions. All versions of Naomi come with a E27 lampholder for energy savers. The switch is situated on the reflector.

Naomi
Naomi Terra
Naomi Head

Naomi



Naomi

Above: adjustable diffuser
and easy access switch
Below: base and pivoting arm



Naomi Terra



Naomi Terra

Right: central articulated joint



Naomi Head Parete



Naomi Head Morsetto
and Pinza

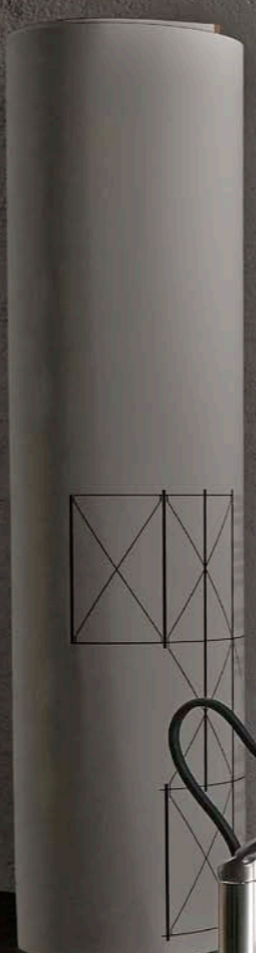

Opus
by Walter Monici

Opus is an essential floor and wall lamp with a very powerful light. It has a practical handle to direct the beam of light accordingly, and a base for the wound cable. A R7s lamp-holder for max 300W halogen bulbs and dimmer on the cable for energy saving.

Opus
Opus Parete



Opus

Above: adjustable diffuser
and easy access handle
Below: base for the wound cable



Opus Parete



Opus Parete

Right: head detail

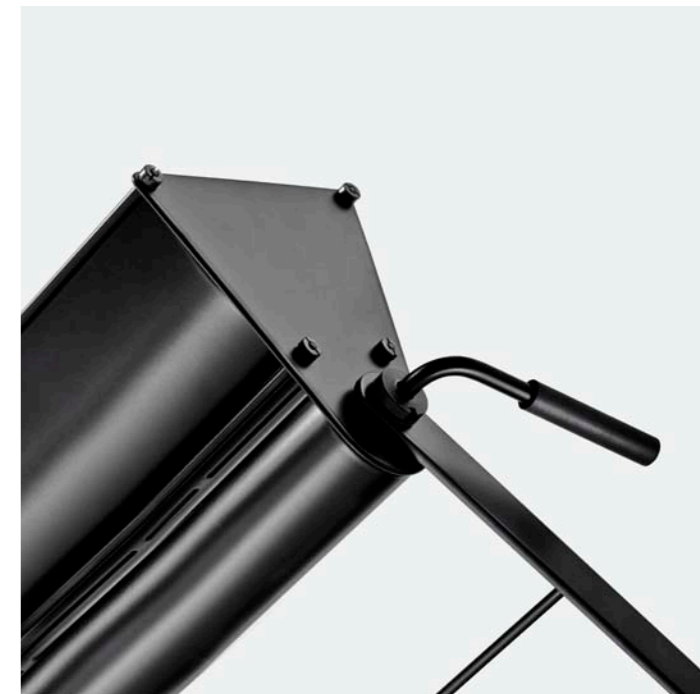

Perla
by Ettore Cimini
& Walter Monici

A simple sphere is the key element of this lighting system, which can be combined with ceiling roses, anchors and supporting cables. The indoor version, Perla, comes with a blown glass sphere diffuser (Ø28 or Ø35cm) and has a lampholder E27. The outdoor version, Perla Garden, is characterized by a polyethylene sphere and an E27 lampholder. Both models are available in solo as well as in modular versions, to create countless configurations.

Perla 28
Perla 35
Perla Garden
Perla Garden Mono

Perla

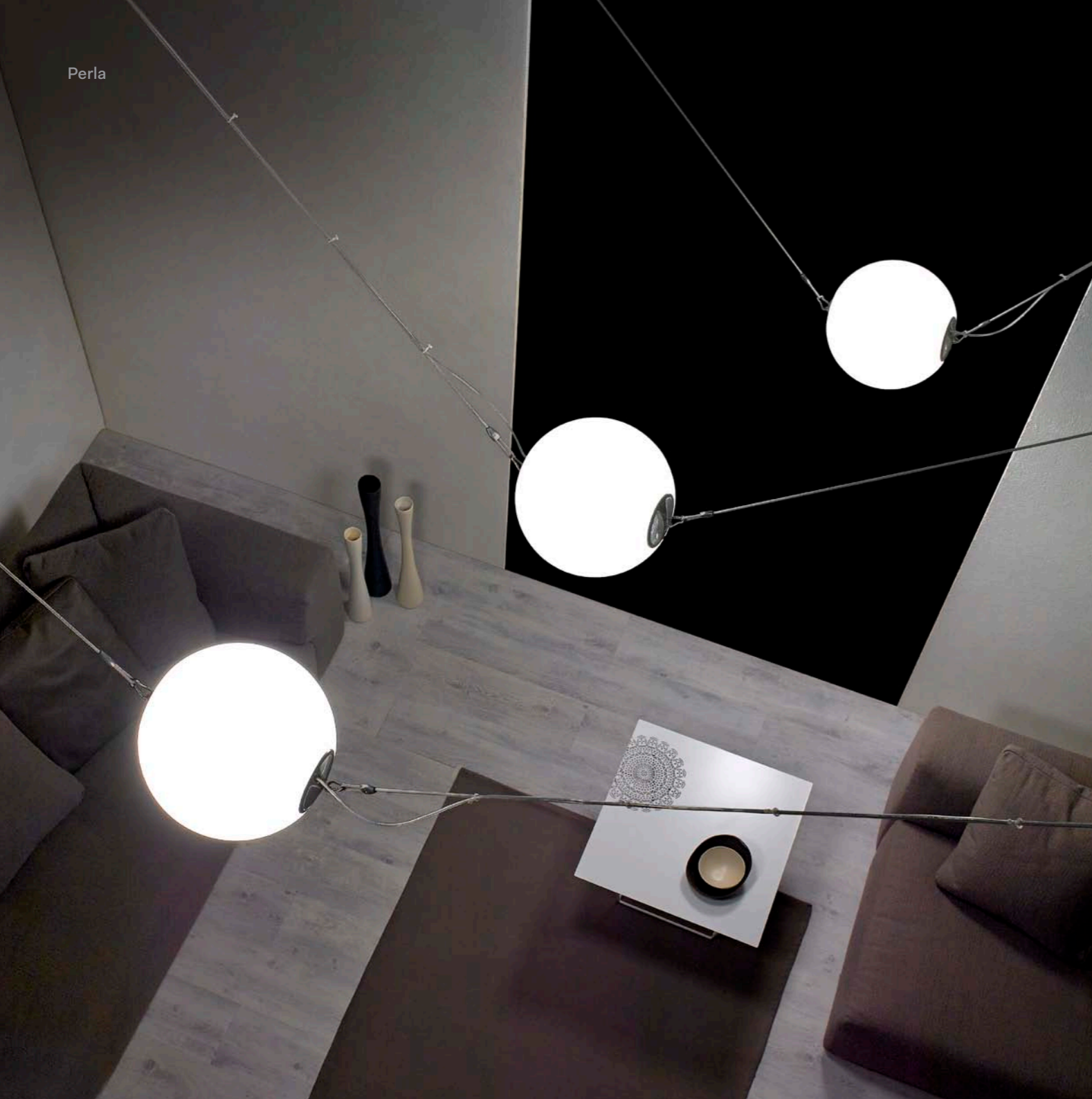

Perla

Above: die-cast aluminium cap
Below: internal frame, patented
by Lumina

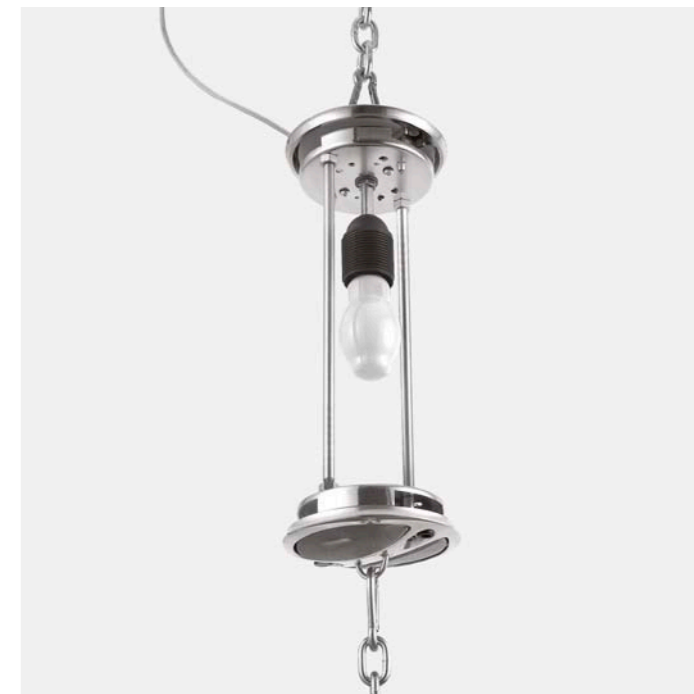

Perla Garden



Perla Garden

Above: white coated die-cast aluminium cap, IP65
Below: stainless steel hitches





Modular System

Perla is a highly personalized lighting system. Its internal frame is designed to hold up to 50kg's worth of tension (Lumina's patent), and thus can be mounted both horizontally and vertically. In particular, it can be mounted in such a way that the fitting is decentralised from its power connection, this being its original feature. Thanks to its simple electric connection other light fittings can be linked to it.

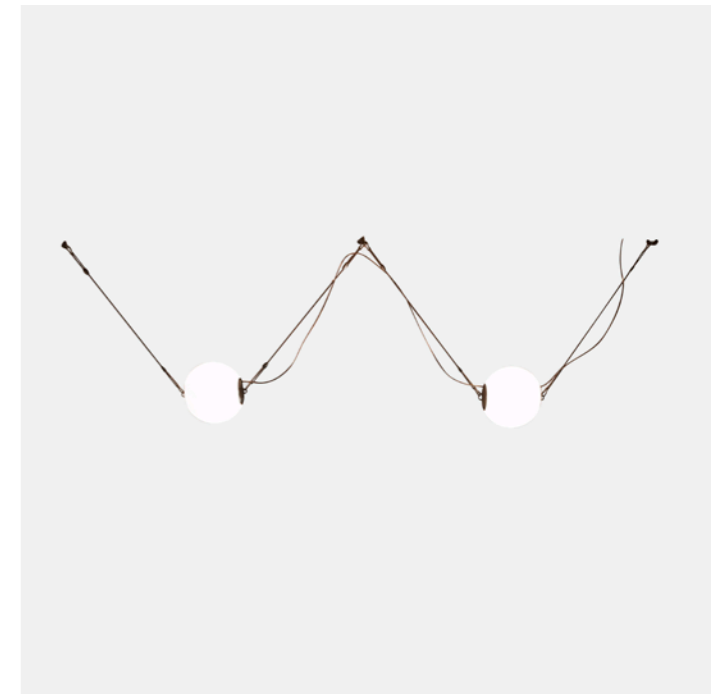

RA
by Ettore Cimini

RA is a technological sculpture that provides maximum visual as well as physical comfort. Its body, made of metal and technopolymers, consists of two fully adjustable arms with silicon fibre optics. RA comes with three dichroic filters that can change the colour of the white light into red, green or blue. Its light beam does not heat. RA is endowed with 50W/12V halogen sources and a touch sensorial dimmer on the body.



Above: adjustable arms
Below: anti-glare grid and
fibre optics



Tangram
by Walter Monici

Tangram represents a series of lamps made of metal and aluminium, with two jointed arms that rotate 360°, in full balance and complete mobility. Tangram comes with many accessories: table and floor standing base, wall and desk mount as well as clamp. A lamp-holder E27 for max 100W halogen sources, dimmable, or energy savers.

Tangram



Tangram

Above: fork of die-cast metal
Below: balanced joint

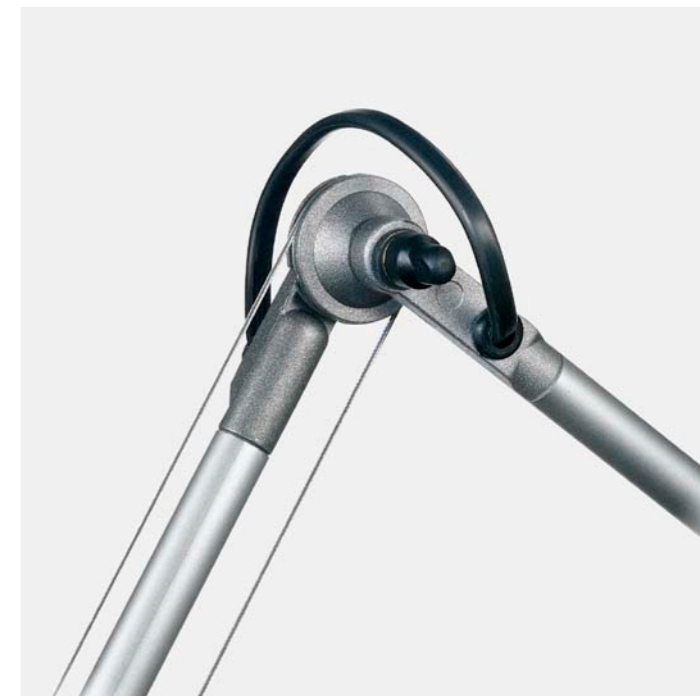

Tangram Terra



Tangram Terra

Right: balancing springs



Zed
by Tommaso Cimini

Zed is the first lamp to have used fibre optics. It is still the perfect night light for reading: it does not heat, it does not disturb, or dazzle. Its flexible arm regulates the beam of light. The vertically diffused light is adjusted through a deflector. Zed and Zed Parete are designed with a lampholder G4 for max 20W/12V, halogen sources. It comes with dimmer.

Zed
Zed Parete

Zed



Zed

Above: open darkening cap
Below: closed darkening cap

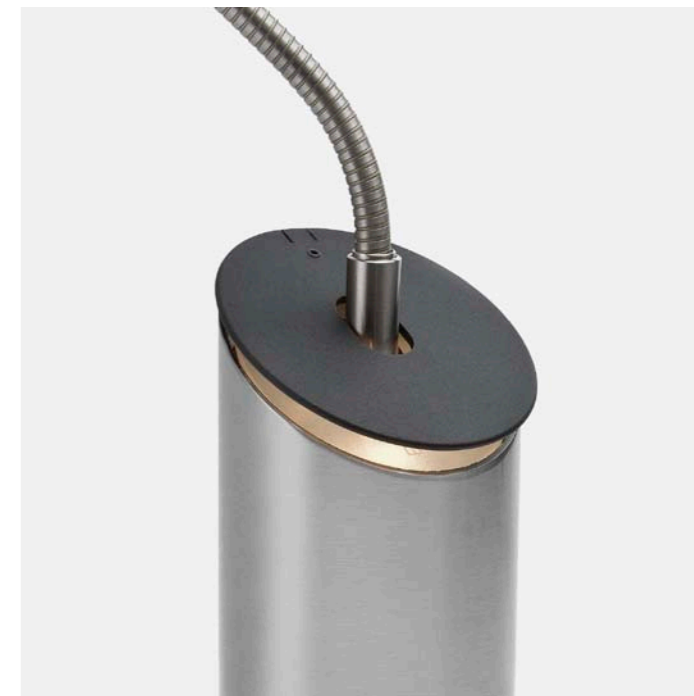
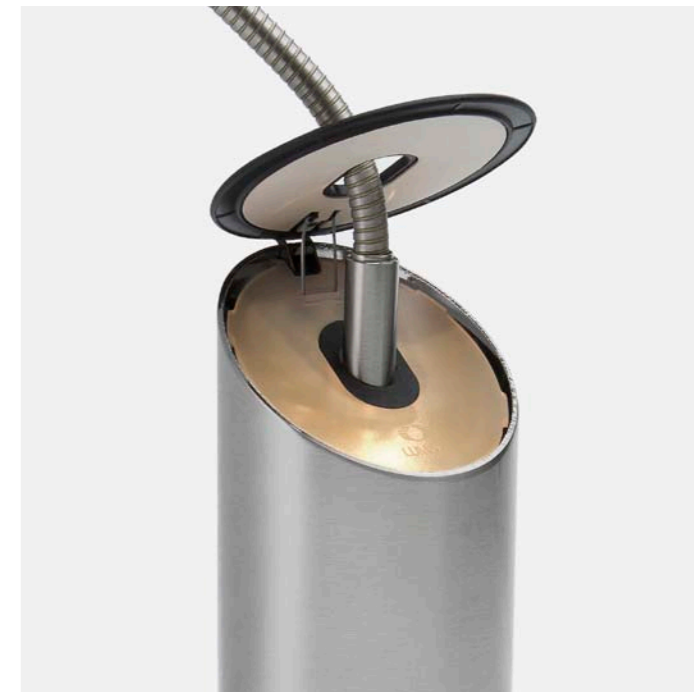

Zed Parete



Zed Parete

Right: Zed Parete detail



Zelig
by Walter Monici

A series of light fittings characterized by two single rotating arms, balanced through one single counter-weight. Zelig offers a surprising mobility and the lack of visible mechanisms enhances its elegance. Lamp-holder GY for halogen sources max 50W/12V; switch or dimmer for energy saving and an built-in base transformer.

Zelig
Zelig Terra

Zelig



Zelig

Above: balancing
counterweight
Below: pivoting base
with dimmer



Zelig Terra



Zelig Terra

Right: adjustable head



Zeta
by Giuseppe Linardi

Minimal series of metal lamps for diffused light with a swivel reflector: Zeta, Zeta Soffitto and Zeta Parete. All versions come with a R7s lamp-holder for max 300W halogen lamps, dimmable or with a dimmer on the cable for energy saving.

Zeta
Zeta Parete
Zeta Soffitto

Zeta



Zeta

Above: base detail
Below: pivoting head



Zeta Soffitto



Zeta Parete



Daphine finishes

01 Black

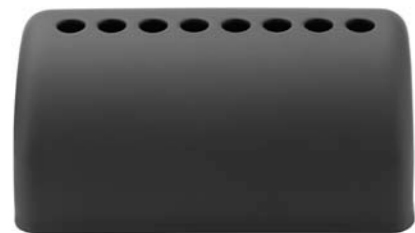

33 Chrome



02op Matt White



44 Brushed Nickel

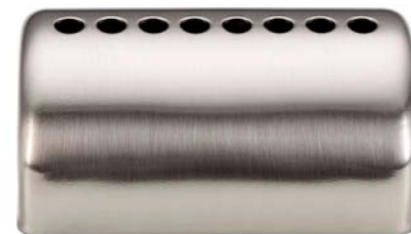

29mt Bronze Metal Paint



Flip finishes

15 Methacrylate



08 Anodised Aluminium



02op Matt White



44 Brushed Nickel



Liz shades

01 Black



13 Ivory



04 Grey



Moove shades

01 Black



13 Ivory



04 Grey



22 Polished Aluminium



Naomi finishes

01st Black Soft-Touch



22 Polished Aluminium



08 Anodised Aluminium



Tangram finishes

01st Black Soft-Touch



44 Brushed Nickel



08 Anodised Aluminium



Daphne specifications

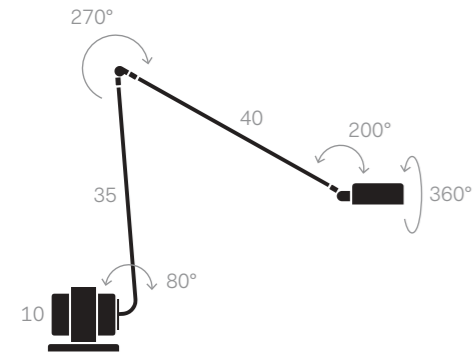

Daphne
Two Step Switch

Source
Max 50W/12V
HAL GY6.35

Code
01C

Certification
CE

Finishes
 01
 02op
 29mt
 33
 44

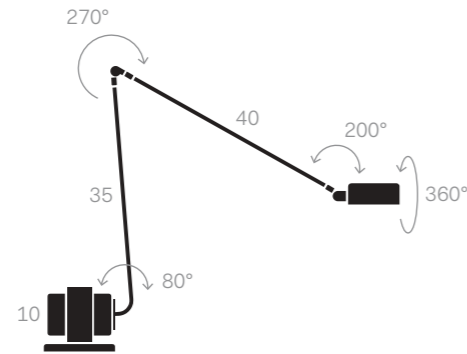

Daphne
Dimmer

Source
Max 50W/12V
HAL GY6.35

Code
03

Certification
CE

Finishes
 01
 02op
 29mt
 33
 44

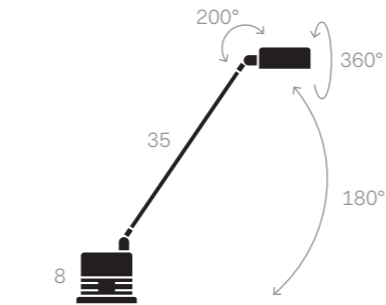

Daphinette
On/Off Switch

Source
Max 20W/12V
HAL G4

Code
09

Certification
CE

Finishes
 01
 02op
 29mt
 33
 44

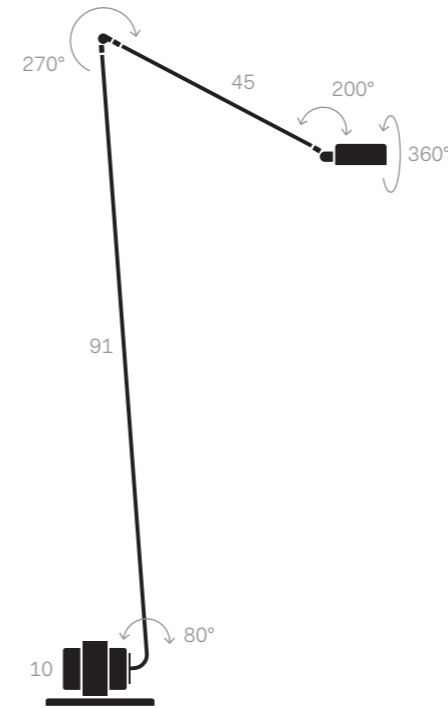

Daphine Terra
Two Step Switch

Source
Max 50W/12V
HAL GY6.35

Code
02C

Certification
CE

Finishes
 01
 02op
 29mt
 33
 44

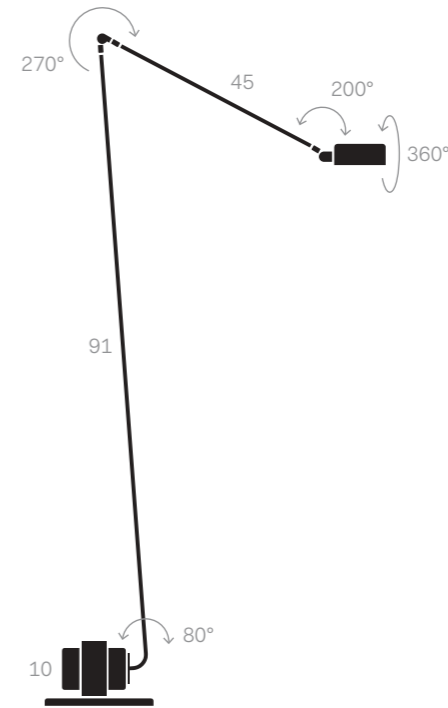

Daphine Terra
Dimmer

Source
Max 50W/12V
HAL GY6.35

Code
04

Certification
CE

Finishes
 01
 02op
 29mt
 33
 44

Daphine specifications

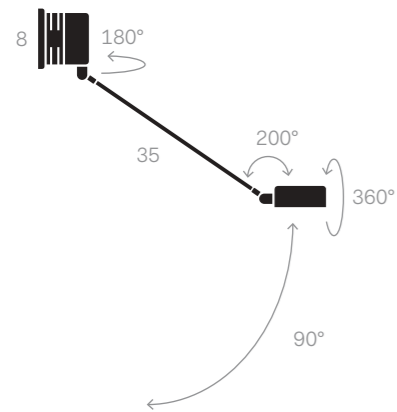

Daphine Parete 35
On/Off Switch

Source
Max 20W/12V
HAL G4

Code
05

Certification
CE

Finishes
 01
 02op
 29mt
 33
 44

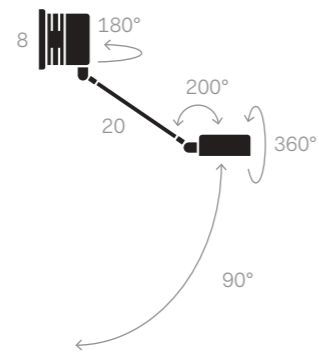

Daphine Parete 20
On/Off Switch

Source
Max 20W/12V
HAL G4

Code
06

Certification
CE

Finishes
 01
 02op
 29mt
 33
 44

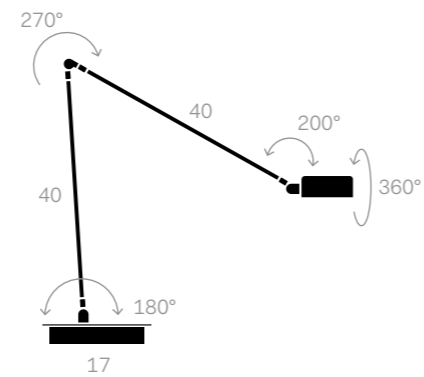

Daphine Cloe
Two Step Switch

Source
Max 50W/12V
HAL GY6.35

Code
07

Certification
CE

Finishes
 01
 02op
 44

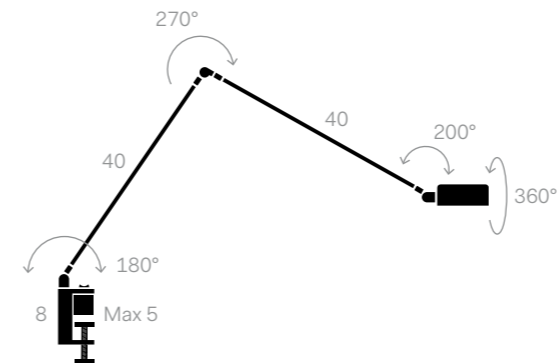

Daphine Cloe Morsetto
Two Step Switch

Source
Max 50W/12V
HAL GY6.35

Code
08

Certification
CE

Finishes
 01
 02op
 44

Elle specifications

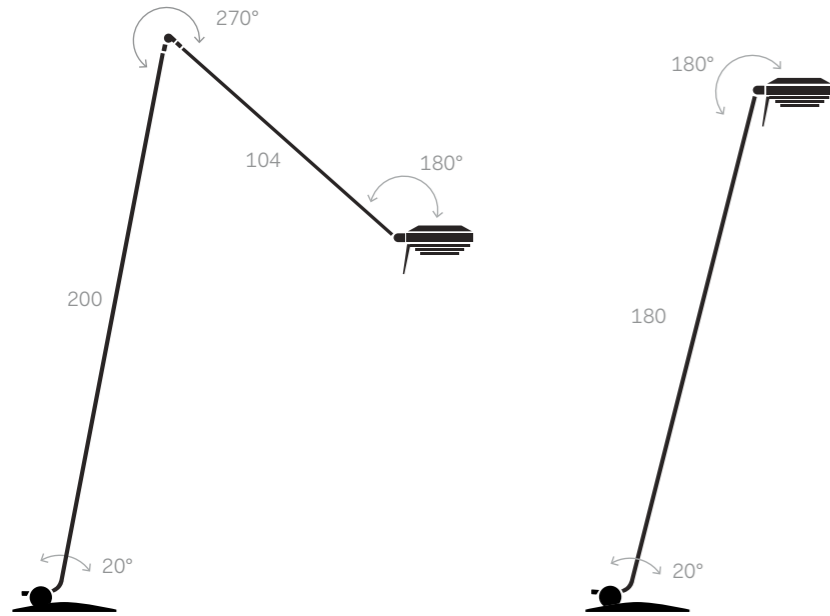

Elle
Dimmer

Source
Max 300W
HAL R7s

Code
60

Certification
CE

Finishes
01st
02op
44

Elle1
Dimmer

Source
Max 300W
HAL R7s

Code
61

Certification
CE

Finishes
01st
02op
44

Flip specifications

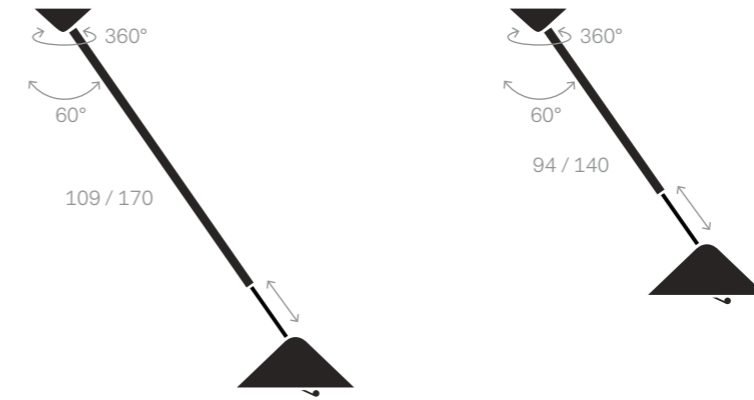

Flip
Dimmable
With dimmable bulbs only

Source
Max 150W
E27

Code
18

Certification
CE

Finishes
02op
08
15
44

Flip
Dimmable
With dimmable bulbs only

Source
Max 150W
E27

Code
22

Certification
CE

Finishes
02op
08
15
44

Galileo specifications

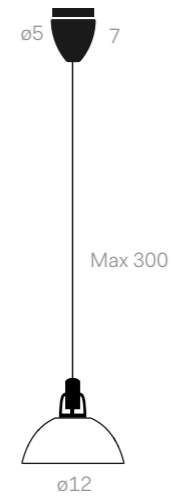
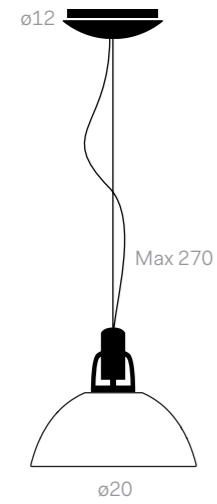

Galileo
Dimmable

Source
Max 100W
HAL B15d

Code
380

Certification
CE

Finishes
 44

Notes
Decentral mount included

Galileo Mini
Dimmable

Source
Max 50W/12V
HAL GY6.35

Code
383

Certification
CE

Finishes
 44

Notes
Decentral mount included

Liz specifications

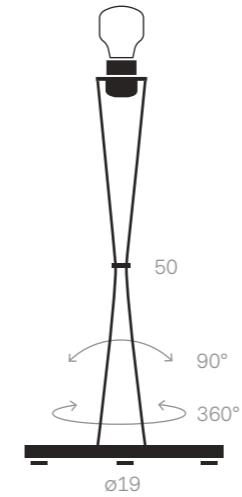

Liz Body
Dimmer

Source
Max 150W
E27

Code
500

Certification
CE 

Finishes
 44

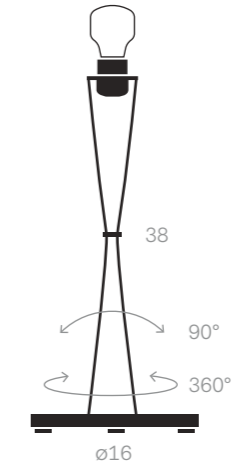

Lizzy Body
Dimmer

Source
MAX 75W
E27

Code
505

Certification
CE 

Finishes
 44

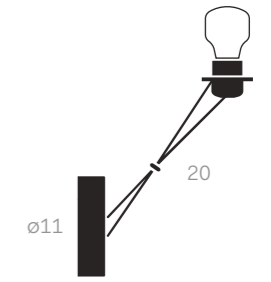

Lizzy Parete Body
Dimmable / No Switch
With dimmable bulbs only

Source
Max 75W
E27

Code
509

Certification
CE

Finishes
 44

Liz specifications

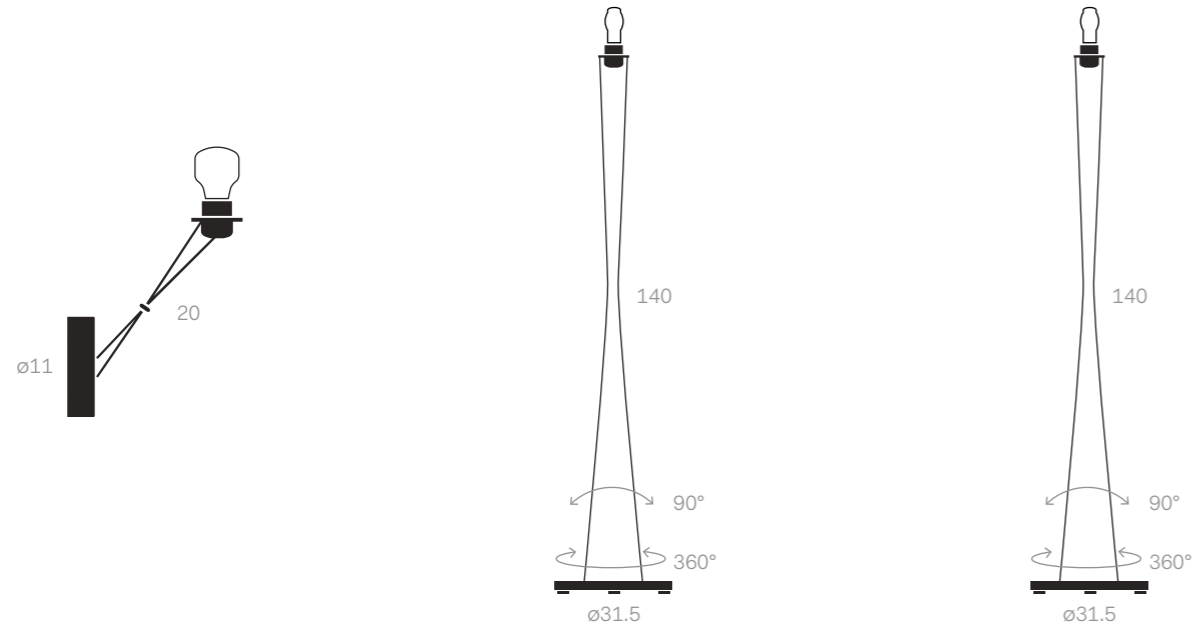

Lizzy Parete/i Body
Dimmable / With Switch
(with dimmable bulbs only)

Source
Max 75W
E27

Code
510

Certification
CE

Finishes
44

Liz Terra S Body
Touch Dimmer

Source
Max 250W
E27

Code
600

Certification
CE

Finishes
44

Liz Terra D Body
Dimmer

Source
Max 250W
E27

Code
602

Certification
CE

Finishes
44

Liz shades specifications

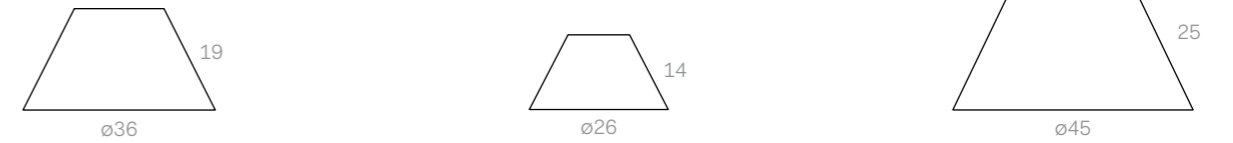

Liz
Conical Shade

Code
501

Finishes
02

Lizzy
Conical Shade

Code
506

Finishes
02

Liz Terra
Conical Shade

Code
606

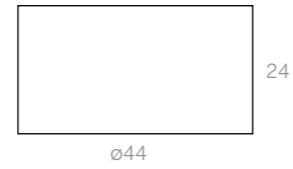

Finishes
02

Liz shades specifications





Liz
Drum Shade

Code
511

Finishes
 01
 04
 13



Lizzy
Drum Shade

Code
516

Finishes
 01
 04
 13

Liz Terra
Drum Shade

Code
616

Finishes
 01
 04
 13

Matrix specifications

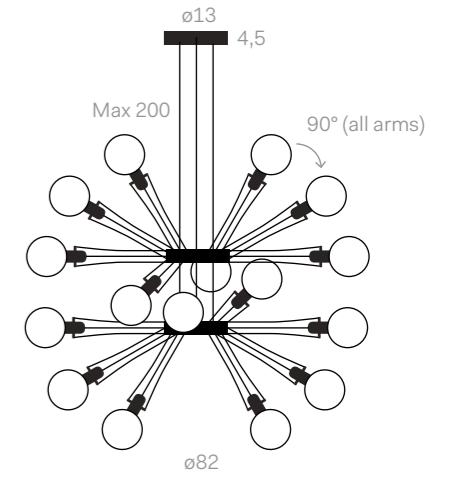
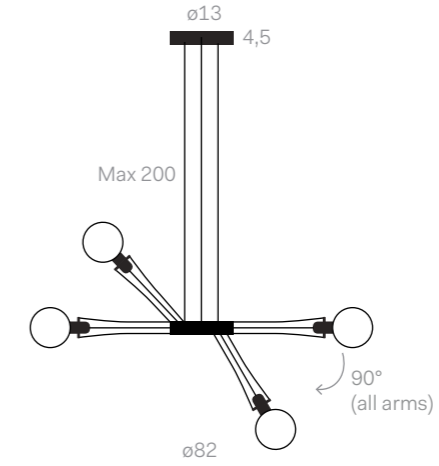
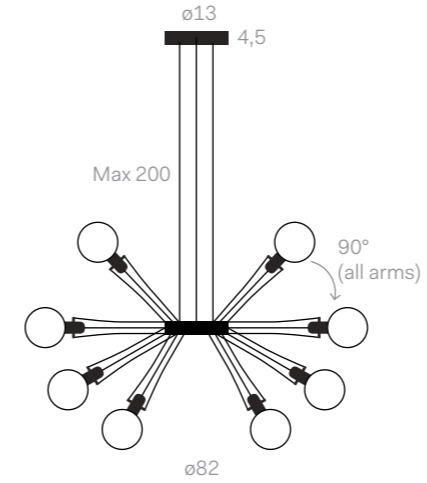



Matrix Otto
Dimmable
With dimmable bulbs only

Source
8 × Max 60W
E27

Code
385

Certification
CE



Finishes
 01st
 44

Matrix Quattro
Dimmable
With dimmable bulbs only

Source
4 × Max 60W
E27

Code
386

Certification
CE



Finishes
 01st
 44

Matrix Doppia
Dimmable
With dimmable bulbs only

Source
16 × Max 60W
E27

Code
387

Certification
CE

Finishes
 01st
 44

Matrix specifications

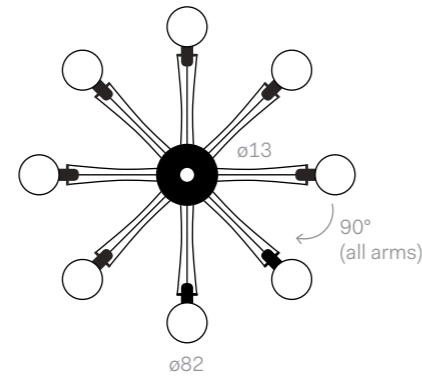
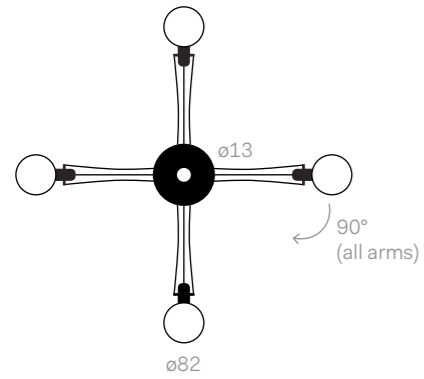

Matrix Quattro P
Dimmable
With dimmable bulbs only

Source
4 × Max 60W
E27

Code
388

Certification
CE

Finishes
■ 01st
■ 44

Matrix Otto P
Dimmable
With dimmable bulbs only

Source
8 × Max 60W
E27

Code
389

Certification
CE

Finishes
■ 01st
■ 44

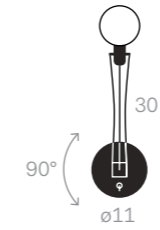

Matrix Mono/I
On/Off

Source
Max 60W
E27

Code
396

Certification
CE

Finishes
■ 01st
■ 44

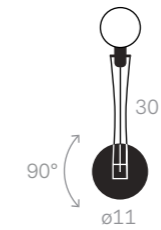

Matrix Mono
Dimmable
With dimmable bulbs only

Source
Max 60W
E27

Code
395

Certification
CE

Finishes
■ 01st
■ 44

Moove specifications

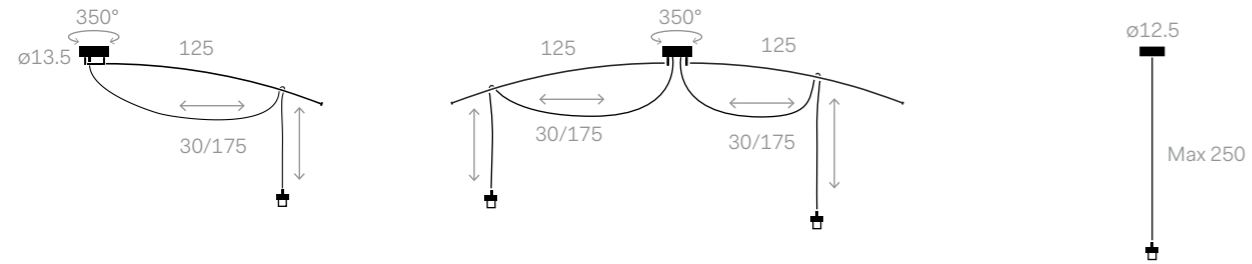

Moove Body
Dimmable
With dimmable bulbs only

Source
Max 150W
E27

Code
750

Certification
CE

Finishes
01st

Moove Doppia Body
Dimmable
With dimmable bulbs only

Source
Max 150W
E27

Code
751

Certification
CE

Finishes
01st

Moove Mono Body
Dimmable
With dimmable bulbs only

Source
Max 150W
E27

Code
752

Certification
CE

Finishes
01st

Moove specifications

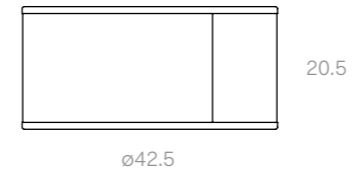

Moove Drum Shade

Code
760

Finishes
01
04
13
22

Multi X specifications

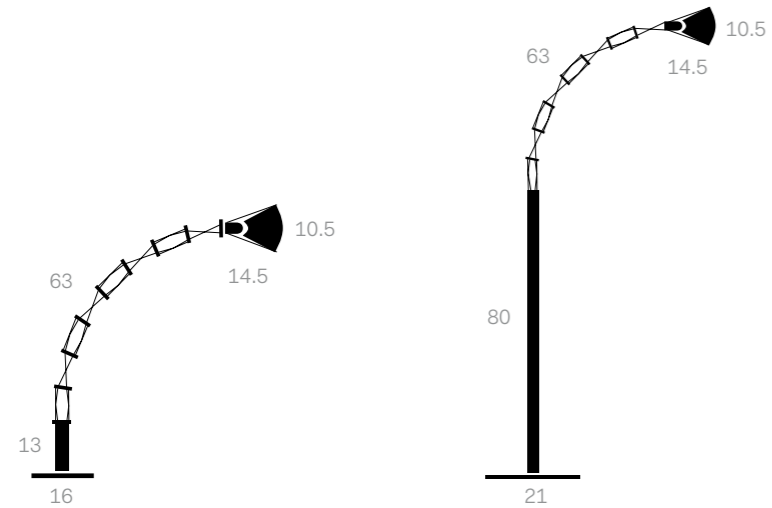

Multi X
On/Off Switch

Source
Max 60W
HAL G9

Code
25

Certification
CE

Finishes
01st
44

Multi X Terra
On/Off Switch

Source
Max 60W
HAL G9

Code
27

Certification
CE

Finishes
01st
44

Naomi specifications

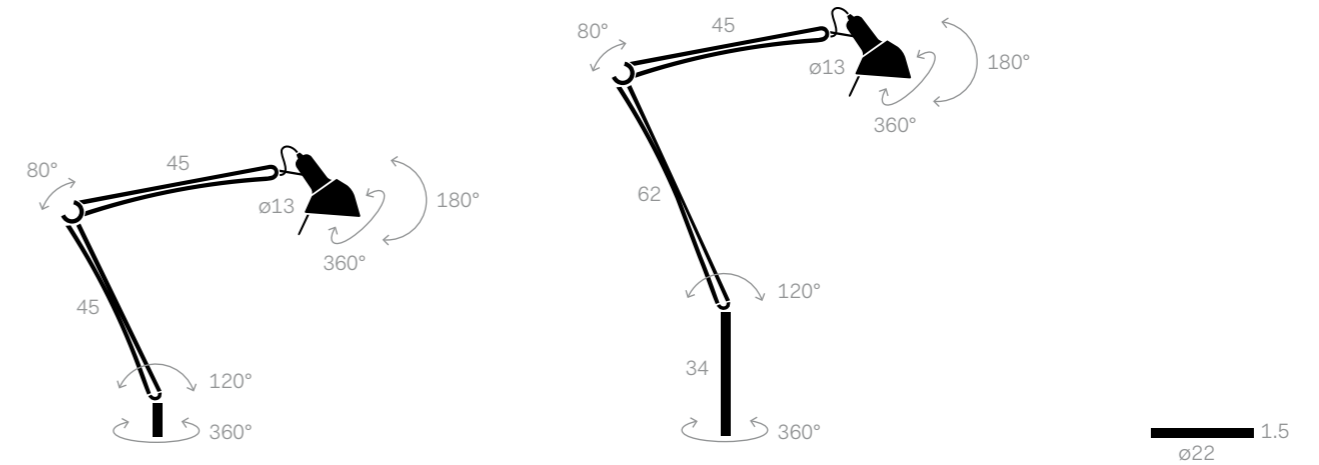

Naomi Body
On/Off Switch

Source
Max 75W
E27

Code
300

Certification
CE

Finishes
01st
08
22

Naomi Terra Body
On/Off Switch

Source
Max 75W
E27

Code
305

Certification
CE

Finishes
01st
08
22

Naomi Base

Code
310

Finishes
01st for body finish 01st
33 for body finish 22
34 for body finish 08

Naomi specifications

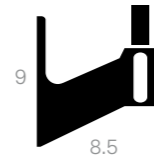
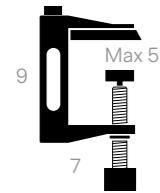

Clamp On

Code
112

Finishes
08

Wall Attachment

Code
113

Finishes
08

Table Mount

Code
332

Finishes
22

Notes
Special fixing devices on request

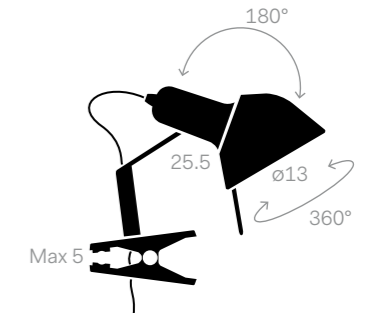
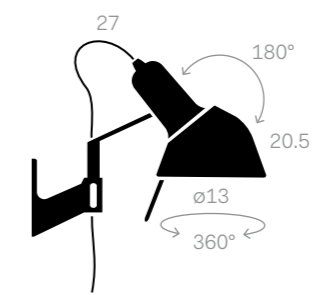
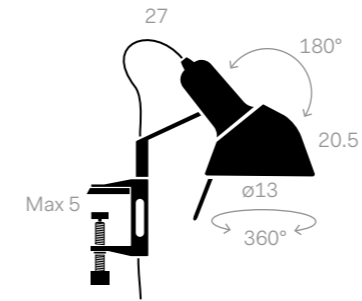

Naomi Morsetto
On/Off Switch

Source
Max 75W
E27

Code
329

Certification
CE

Finishes
08

Naomi Parete
On/Off Switch

Source
Max 75W
E27

Code
330

Certification
CE

Finishes
08

Naomi Pinza
On/Off Switch

Source
Max 75W
E27

Code
328

Certification
CE

Finishes
08

Opus specifications

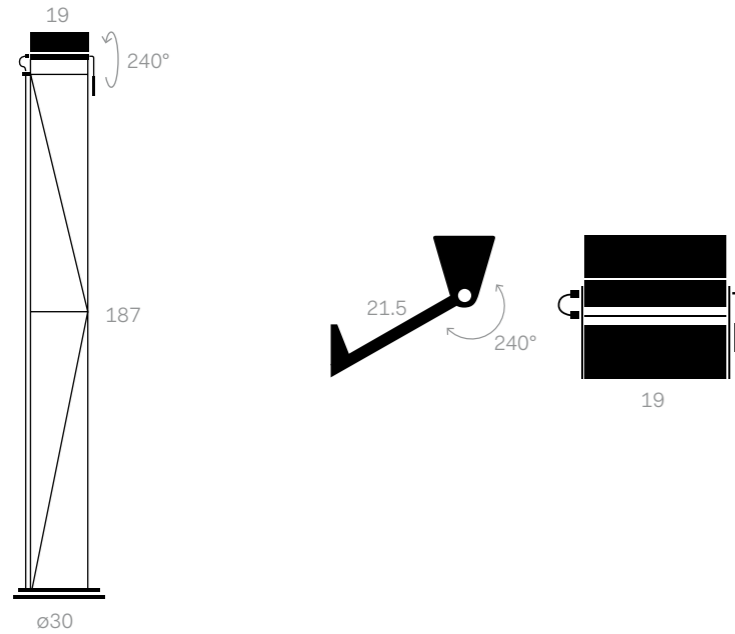

Opus
Dimmer

Source
Max 300W
HAL R7s

Code
70

Certification
CE

Finishes
 01st
 02op

Opus Parete
Dimmable

Source
Max 300W
HAL R7s

Code
71

Certification
CE

Finishes
 01st
 02op

Perla specifications

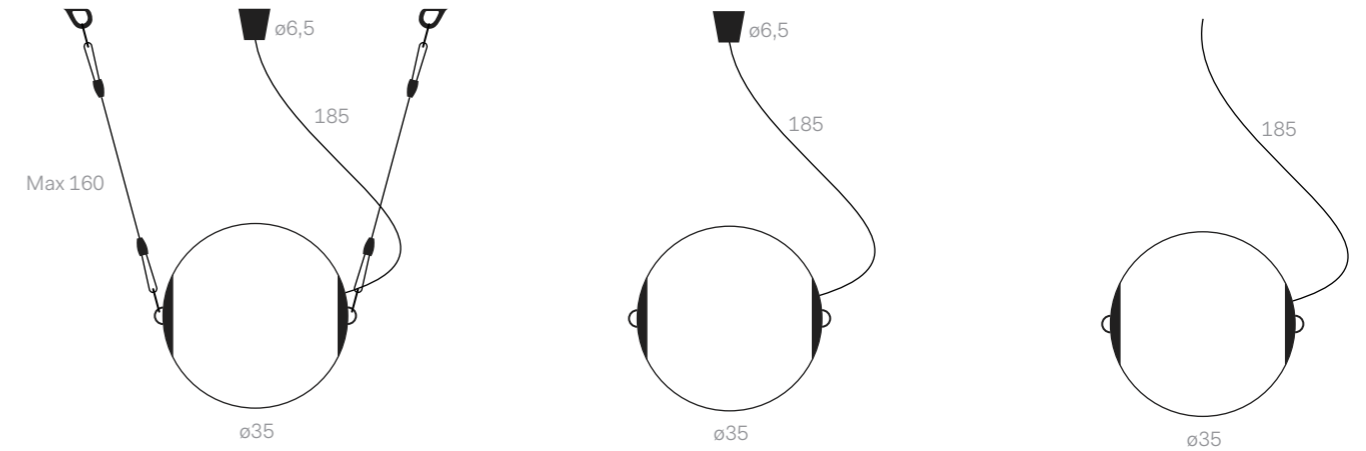

Perla 35
Dimmable
With dimmable bulbs only

Source
Max 30W-FL
Max 150W-HAL
E27

Code
800

Certification
CE

Finishes
 22

Perla 35 SC
Dimmable
With dimmable bulbs only

Source
Max 30W-FL
Max 150W-HAL
E27

Code
801

Certification
CE

Finishes
 22

Perla 35 M
Dimmable
With dimmable bulbs only

Source
Max 30W-FL
Max 150W-HAL
E27

Code
802

Certification
CE

Finishes
 22

Perla specifications

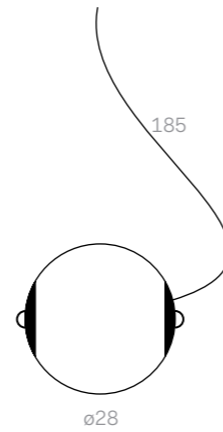
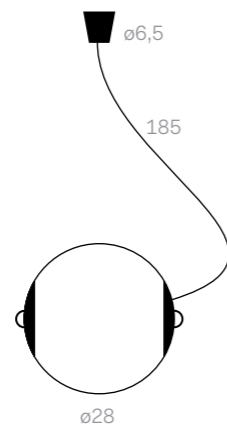
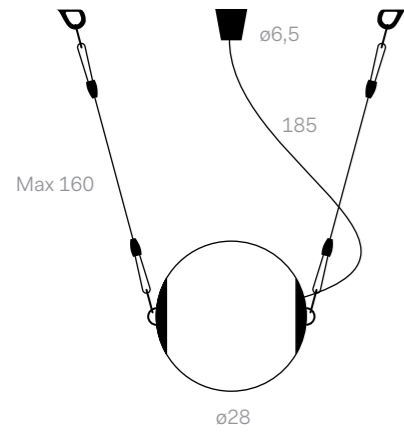

Perla 28
Dimmable
With dimmable bulbs only

Source
Max 30W-FL
Max 150W-HAL
E27

Code
810

Certification
CE

Finishes
22

Perla 28 SC
Dimmable
With dimmable bulbs only

Source
Max 30W-FL
Max 150W-HAL
E27

Code
811

Certification
CE

Finishes
22

Perla 28 M
Dimmable
With dimmable bulbs only

Source
Max 30W-FL
Max 150W-HAL
E27

Code
812

Certification
CE

Finishes
22

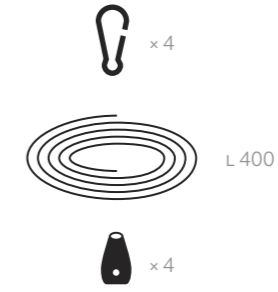
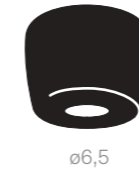

Perla Ceiling Rose

Code
825

Finishes
22

Notes
Indoor use only

Perla Set Ropes

Code
820

Finishes
22

Perla Set Hooks

Code
821

Finishes
22

Perla specifications

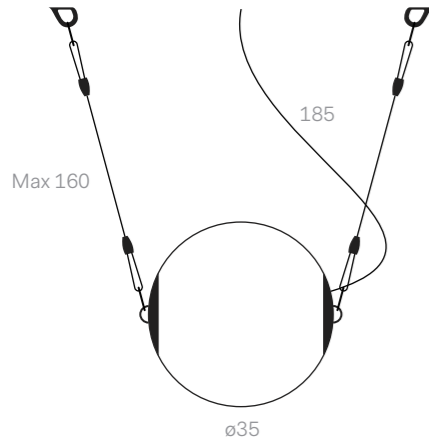

Perla Garden 35
Dimmable
With dimmable bulbs only

Source
Max 30W-FL
Max 60W-HAL
E27

Code
860

Certification
CE IP65

Finishes
02



Perla Garden 35 M
Dimmable
With dimmable bulbs only

Source
Max 30W-FL
Max 60W-HAL
E27

Code
861

Certification
CE IP65

Finishes
02



Perla Mono 35
Dimmable
With dimmable bulbs only

Source
Max 30W-FL
Max 60W-HAL
E27

Code
850

Certification
CE IP65

Finishes
02

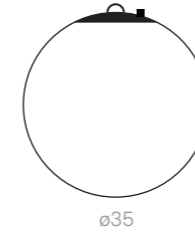

Perla Mono 35 M
Dimmable
With dimmable bulbs only

Source
Max 30W-FL
Max 60W-HAL
E27

Code
851

Certification
CE IP65

Finishes
02

RA specifications



RA
Touch Dimmer

Source
50W/12V KLS
Phillips cod.12998

Code
350

Certification
CE 

Finishes
 33

Tangram specifications

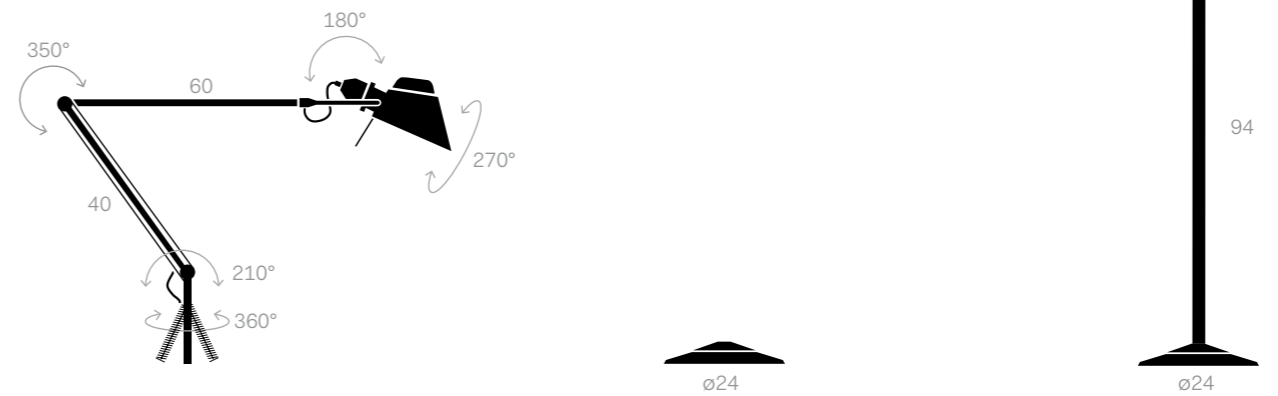



Tangram Body
On/Off Switch

Source
Max 100W-HAL
E27



Code
101

Certification
CE 

Finishes
 01st
 08
 44



Tangram Table Base

Code
114

Finishes
 01st for body finish 01st
 19 for body finish 08
 44 for body finish 44

Tangram Floor Base

Code
125

Finishes
 01st for body finish 01st
 19 for body finish 08
 44 for body finish 44

Tangram specifications

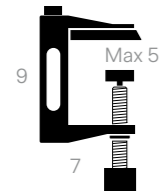

Clamp On

Code
112

Finishes
08

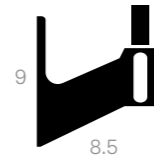

Wall Attachment

Code
113

Finishes
08

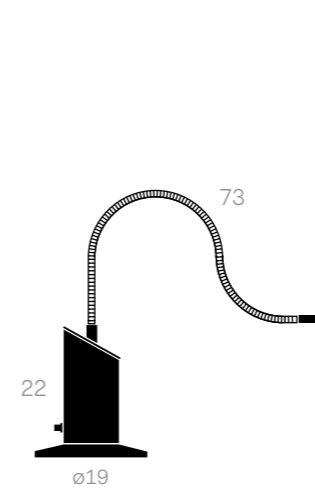

Table Mount

Code
332

Finishes
22

Zed specifications



Zed Dimmer

Source
Max 20W/12V
HAL G4

Code
91

Certification
CE

Finishes
01st
44

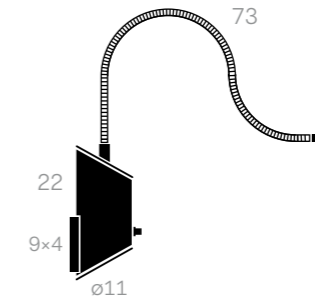

Zed Parete Dimmer

Source
Max 20W/12V
HAL G4

Code
89

Certification
CE

Finishes
01st
44

Zelig specifications

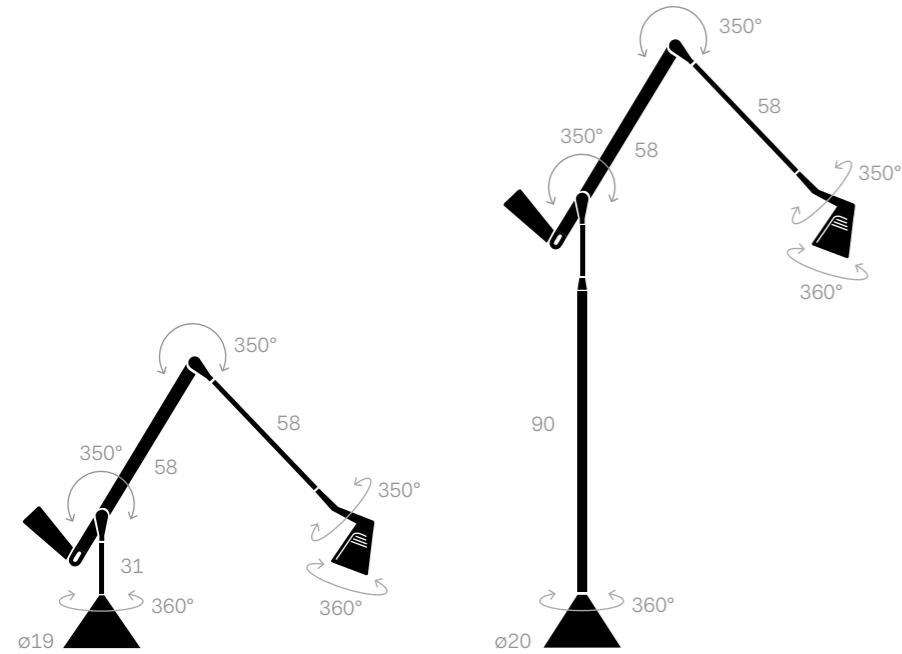

Zelig Dimmer Dimmer

Source
Max 50W/12V
HAL GY6.35

Code
23

Certification
CE

Finishes
 01st
 02op
 44

Zelig Terra Dimmer Dimmer

Source
Max 50W/12V
HAL GY6.35

Code
26

Certification
CE

Finishes
 01st
 02op
 44

Zeta specifications

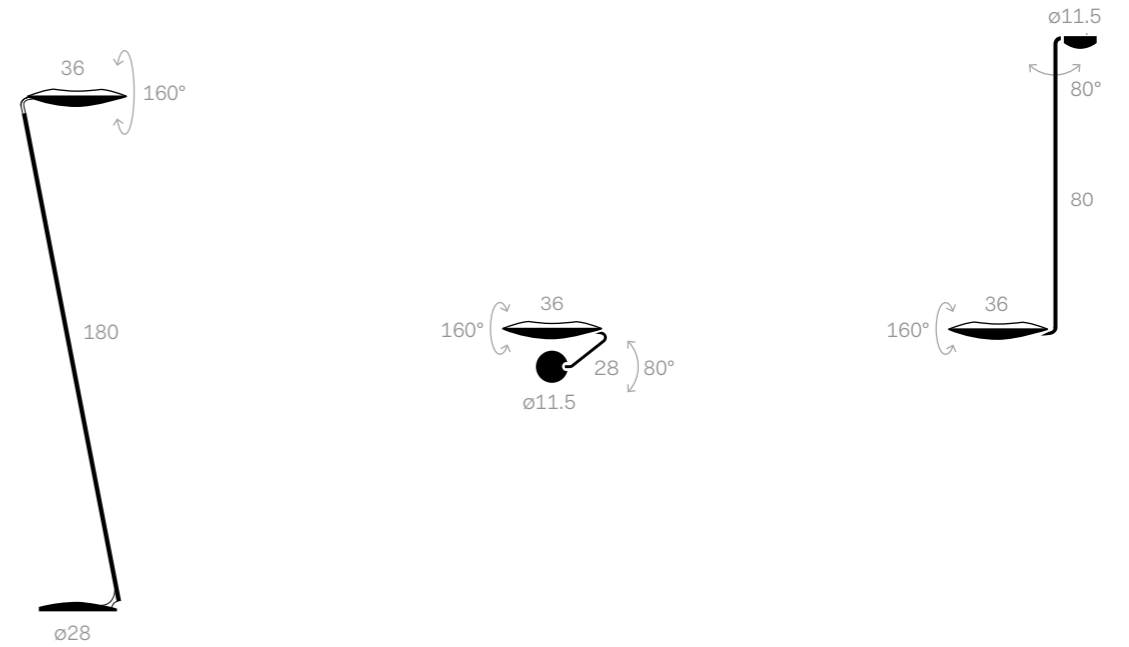

Zeta Dimmer

Source
Max 300W
HAL R7s

Code
75

Certification
CE

Finishes
 01st
 02op

Zeta Parete Dimmable

Source
Max 300W
HAL R7s

Code
77

Certification
CE

Finishes
 01st
 02op

Zeta Soffitto Dimmable

Source
Max 300W
HAL R7s

Code
76

Certification
CE

Finishes
 01st
 02op



LUMINA Italia SrL, Via Casorezzo 63
20010 Arluno, Milano, Italia
Tel +39 0290 3752, www.lumina.it