

LUCE  
MATERIA  
SPAZIO

MOROSINI®



**MOROSINI®**



# INDICE INDEX

46 ARCHETYPE  
TECHNICAL DATE P.54

124 FOG PLISSÉ  
TECHNICAL DATE P.132

170 BIA  
TECHNICAL DATE P.178

196 GADORA  
TECHNICAL DATE P.208

144 DIAMOND  
TECHNICAL DATE P.149

156 EGG  
TECHNICAL DATE P.161

34 FAYA  
TECHNICAL DATE P.44

110 FOG  
TECHNICAL DATE P.122



210 GADORA CHIC  
TECHNICAL DATE P.220

150 IN & OUT  
TECHNICAL DATE P.155

180 MEMORIA  
TECHNICAL DATE P.193

68 MIKADO  
TECHNICAL DATE P.80

84 MIKADO ZERO  
TECHNICAL DATE P.88

06 OUTLIER  
TECHNICAL DATE P.18

92 PANK  
TECHNICAL DATE P.108

134 RIBBON  
TECHNICAL DATE P.142

222 SAN MARCO  
TECHNICAL DATE P.236

56 SANTRAL  
TECHNICAL DATE P.66

162 SUNRISE ECO  
TECHNICAL DATE P.169

22 VERSATILE  
TECHNICAL DATE P.30

## DESIGNERS



massimo  
TONETTO



marco  
TAIETTA

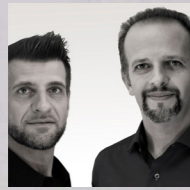

romani saccani  
ARCHITETTI  
ASSOCIATI



dima  
LOGINOFF



andrea  
LAZZARI



tiziano  
MAFFIONE



filippo  
MAMBRETTI



manuel borri  
DIAGORA DESIGN



sandro  
SANTANTONIO



studio  
PANG

## SPERIMENTARE LA MATERIA, RICONCEPIRE LO SPAZIO.

Morosini esprime l'essenza più sperimentale del design dell'illuminazione.

Le sue creazioni comunicano la volontà di tracciare nuove frontiere nello stile contemporaneo, rendendo attuali scelte all'avanguardia per mix dei materiali, originalità estetica e compatibilità con l'ambiente. Nello studio della luce e nella pulizia assoluta delle linee risiede la vera anima di **Morosini**, un'anima eclettica, a volte provocatoria, in un continuo match di rimandi, contrasti e ispirazioni con i gusti e l'arredamento moderno.

Morosini abbina la creatività dirompente di designer emergenti alla qualità produttiva di taglio artigianale tipica del Made in Italy.

Un'idea esclusiva, sorprendente, già conosciuta e riconosciuta in tutto il mondo.

## EXPERIMENT THE MATERIAL, REDESIGN THE SPACE.

Morosini expresses the most experimental essence of lighting design.

Its creations communicate the desire to draw new borders in the contemporary style, making current the choices in the vanguard thanks to the mix of materials, originality and aesthetic compatibility with the environment. The real soul of **Morosini** is clear in the study of light and in the absolute cleanliness of the lines, an eclectic soul, sometimes provocative, in an ongoing match of references, contrasts and inspirations with the modern tastes and decor.

The typical traditional cut production quality of Made in Italy and the explosive creativity of the emerging designers are combined within **Morosini**.

An exclusive, unexpected, idea already known and recognized worldwide.





# OUTLIER

design\_Tiziano Maffione

Armonia di geometrie,  
l'eleganza della semplicità

Harmony of geometries,  
the elegance of simplicity



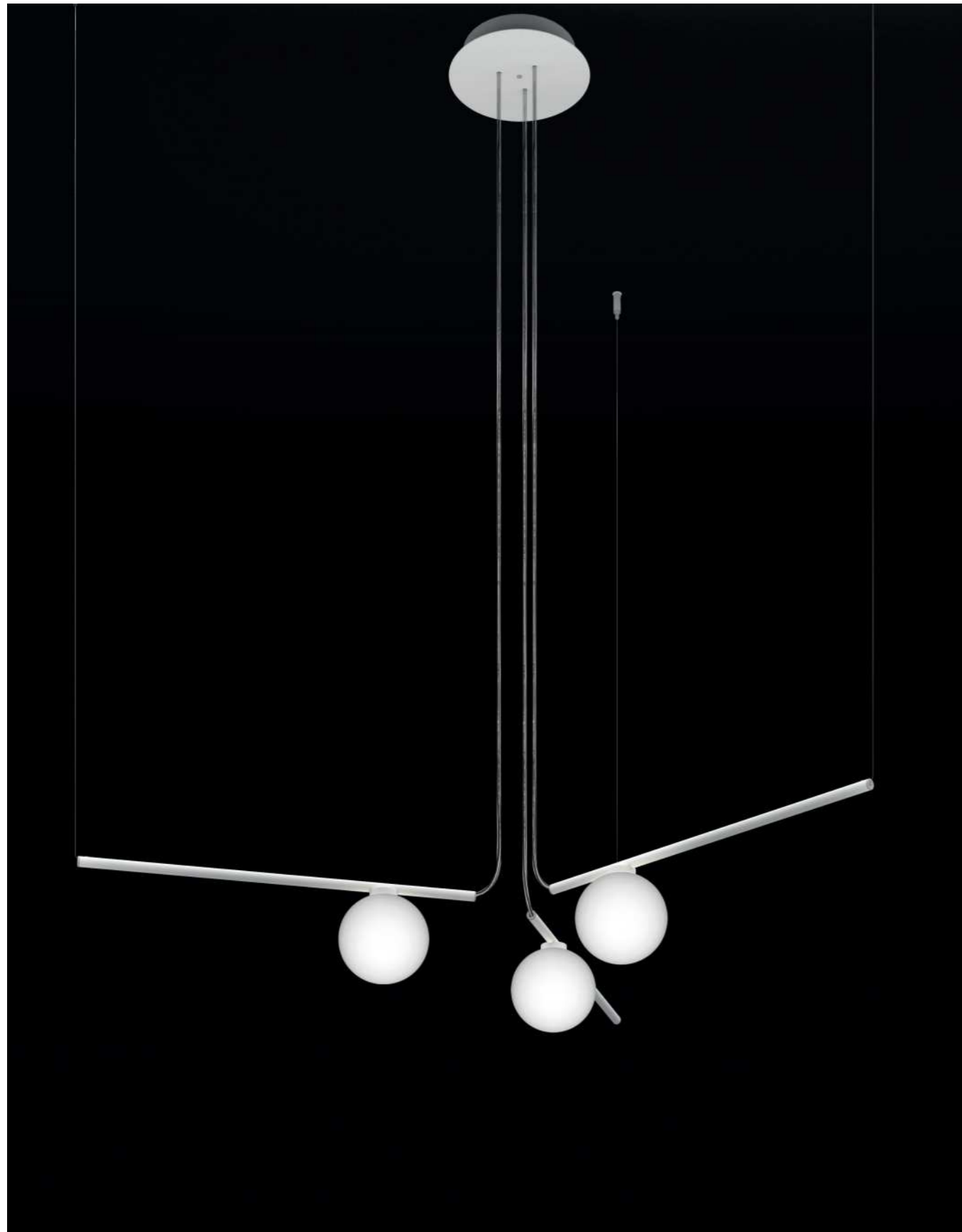

Outlier\_LA3 INT



Outlier\_LA6 EXT





Outlier\_SO6

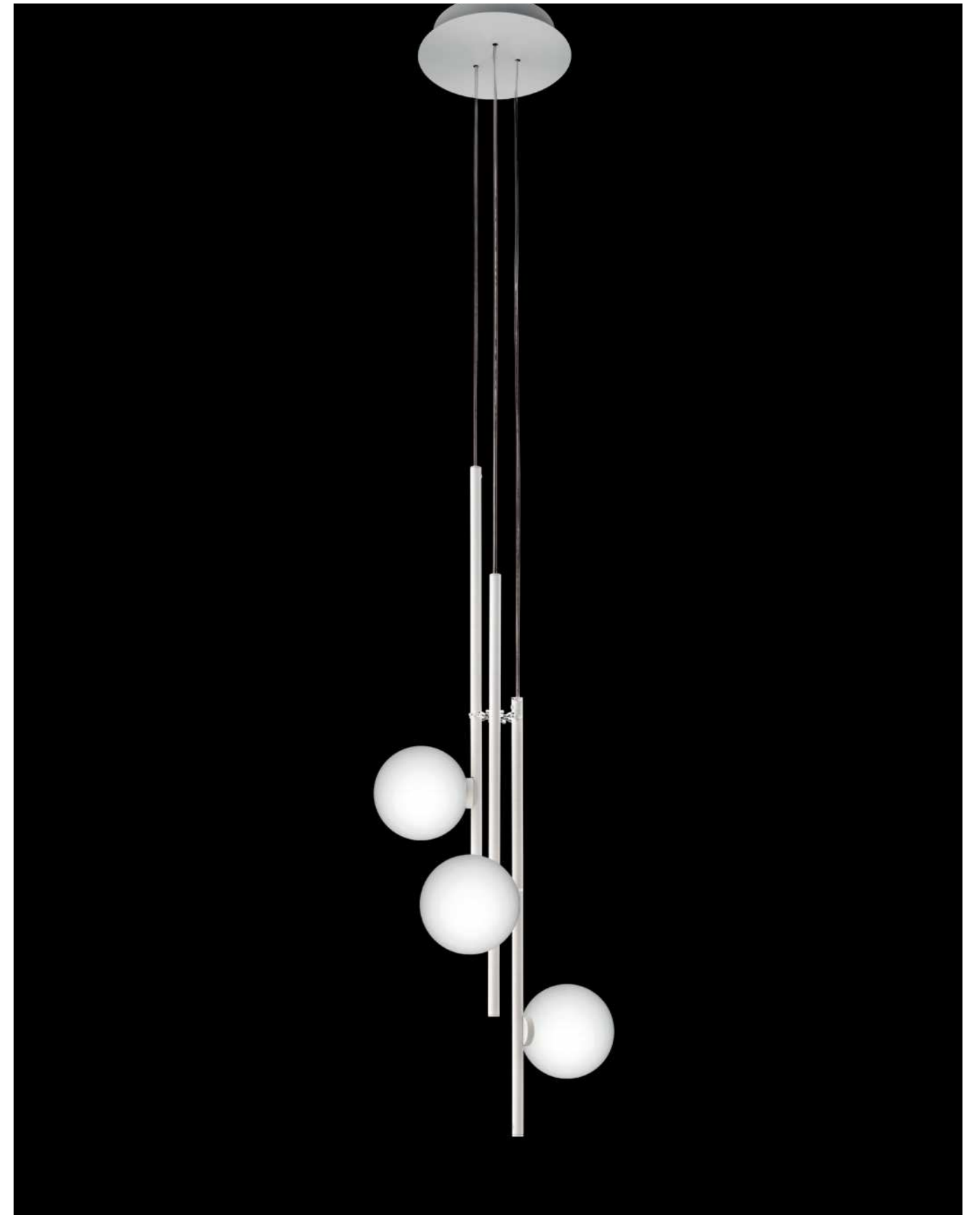

Outlier\_SO3





Outlier\_PA\_C



Outlier\_PA\_M





Outlier\_LA12 ALT esempio di composizione/example of composition



Outlier\_CO





Outlier\_SO1



Outlier\_LA12 EXT\_ esempio di composizione/example of composition



# OUTLIER

## \_technical data

Una lampada creata da una sfera di luce e un'asta unite in una composizione sbilanciata che definisce così il concetto di Outlier: un'entità che si differenzia dal resto del gruppo. Un'anomalia nella normalità.

Un'anomalia che crea unicità, un'unicità che crea ricercatezza e che dona all'ambiente quell'eccezione che attrae e che dà fascino.

Une lampe créée d'une sphère de lumière et d'une tige unique dans une composition déséquilibrée qui définit ainsi le concept d'Outlier: une entité singulière qui peut se démarquer du reste du groupe « Comme une anomalie dans la normalité ».

Anomalie qui crée l'unicité, une unicité qui crée du raffinement et qui donne à l'environnement cette exception qui attire et donne du charme.

Outlier contraste grandement avec les propositions habituellement imaginées.

A lamp created by a sphere of light and a rod united in an unbalanced composition that thus defines the concept of Outlier: an entity that differs from the rest of the group. An anomaly in normality.

An anomaly that creates uniqueness, a uniqueness that creates refinement and that gives the environment that exception that attracts and gives charm.

Una lámpara creada por una esfera de luz y una varilla unidas en una composición desequilibrada que define así el concepto de Outlier: una entidad que se diferencia del resto del grupo. Una anomalía en la normalidad.

Una anomalía que crea singularidad, una singularidad que crea refinamiento y que da al ambiente esa excepción que atrae y da encanto.

Eine Lampe, die aus einer Lichtkugel und einem Stab besteht, die in einer unausgewogenen Komposition vereint sind und so das Konzept von Outlier definieren: eine Einheit, die sich vom Rest der Gruppe unterscheidet. Eine Anomalie in der Normalität.

Eine Anomalie, die Einzigartigkeit schafft, eine Einzigartigkeit, die Raffinesse schafft und der Umgebung diese Ausnahme verleiht, die anzieht und Charme verleiht.

Лампа, созданная из светящейся сферы и стержня, объединенных в композицию с изменяемым балансом. Это и определяет концепцию Outlier: сущность, которая отличается от остальной группы. Аномалия в норме.

Аномалия, которая создает уникальность, уникальность, которая создает утонченность и придает окружающей среде ту исключительность, которая привлекает и придает очарование.

**Rosone:** bianco opaco.

**Struttura:** metallo nelle colorazioni bianco opaco, bronzo spazzolato, oro spazzolato.

**Diffusore:** vetro soffiato bianco latte satinato.

**Canopy:** matt white.

**Frame:** metal in the colors matt white, brushed bronze, brushed gold.

**Diffuser:** milk white satin blown glass.

**Baldachin:** weiß matt.

**Struktur:** metall in den Farben Weiß matt, Bronze gebürstet, Gold gebürstet.

**Diffusor:** milchweiß satiniertes mundgeblasenes Glas.

**Rosette:** blanc mat.

**Structure:** métal dans les couleurs blanc mat, bronze brossé, or brossé.

**Diffuseur:** verre soufflé satiné blanc lait.

**Florón:** blanco mate.

**Estructura:** metal en los colores blanco mate, bronce cepillado, oro cepillado.

**Difusor:** vidrio soplado satinado blanco leche.

**Основание:** матовое белое.

**Структура:** металл матового белого цвета, брашированная бронза, брашированное золото.

**Рассеиватель:** молочно-белое сатинированное выдувное стекло.



**06:** Bianco opaco/  
Matte white



**32:** Bronzo spazzolato/  
Brushed bronze



**33:** Oro spazzolato/  
Brushed gold

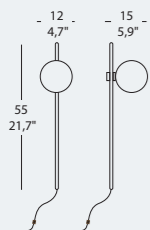

### OUTLIER PA\_C

1 x MAX 4,8W G9 LED

CE F IP20 EAC

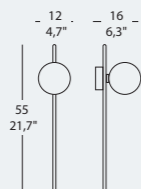

### OUTLIER PA\_M

1 x MAX 4,8W G9 LED

CE F IP20 EAC

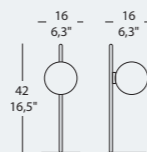

### OUTLIER CO

1 x MAX 4,8W G9 LED

CE F IP20 EAC

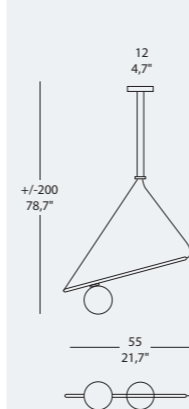
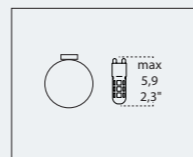

### OUTLIER S01

1 x MAX 4,8W G9 LED

CE F IP20 EAC

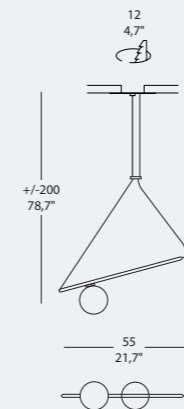

### OUTLIER IN1

1 x MAX 4,8W G9 LED

CE F IP20 EAC

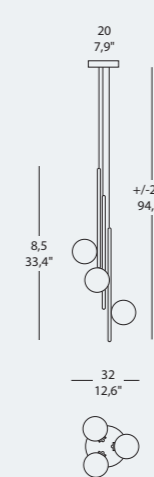

### OUTLIER S03

3 x MAX 4,8W G9 LED

CE F IP20 EAC

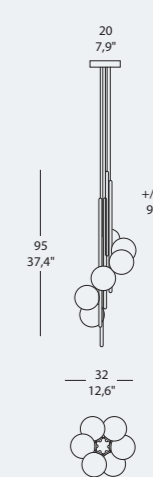

### OUTLIER S06

6 x MAX 4,8W G9 LED

CE F IP20 EAC

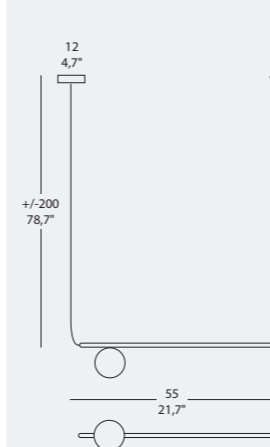

### OUTLIER SO L INT

1 x MAX 4,8W G9 LED

CE F IP20 EAC

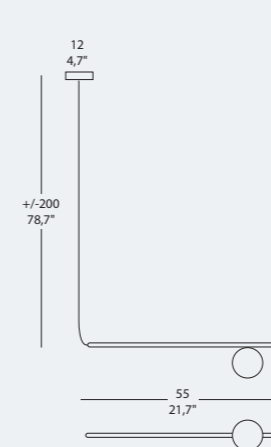

### OUTLIER SO L EXT

1 x MAX 4,8W G9 LED

CE F IP20 EAC

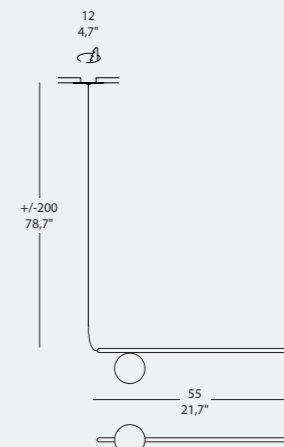

### OUTLIER IN L INT

1 x MAX 4,8W G9 LED

CE F IP20 EAC

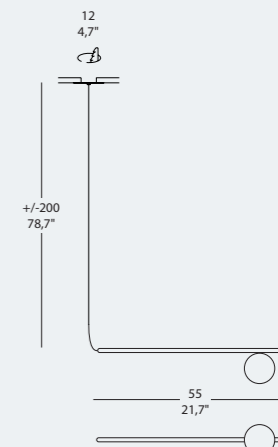

### OUTLIER IN L EXT

1 x MAX 4,8W G9 LED

CE F IP20 EAC

## ESEMPIO DI COMPOSIZIONE/EXAMPLE OF COMPOSITION

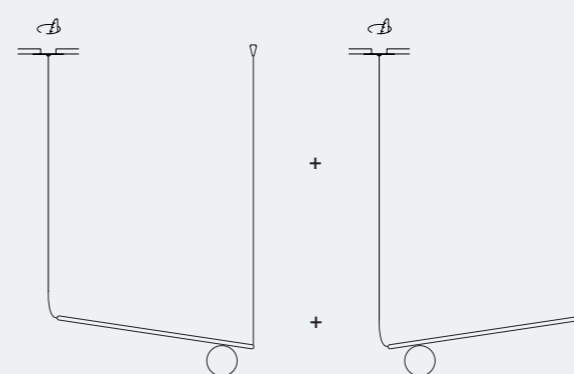

N° 4 OUTLIER IN L INT

N° 5 OUTLIER IN L EXT

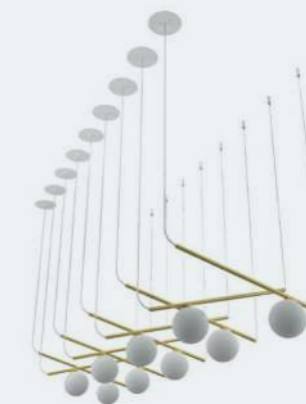



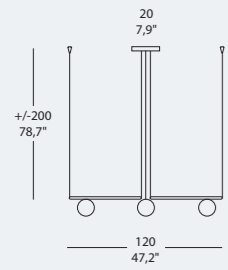

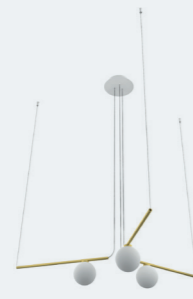
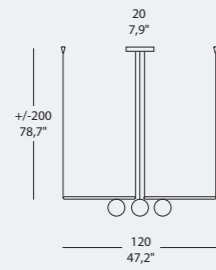

**OUTLIER LA3 EXT**  
3 x MAX 4,8W G9 LED   
CE  IP 20 EAC



**OUTLIER LA3 INT**  
3 x MAX 4,8W G9 LED   
CE  IP 20 EAC

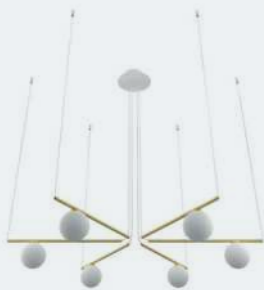
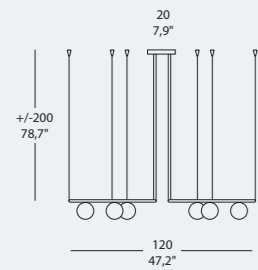

**OUTLIER LA6 EXT**  
6 x MAX 4,8W G9 LED   
CE  IP 20 EAC

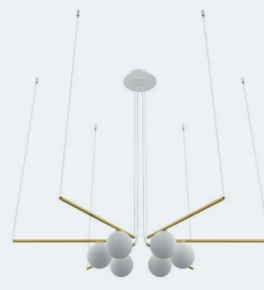
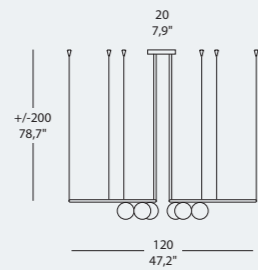

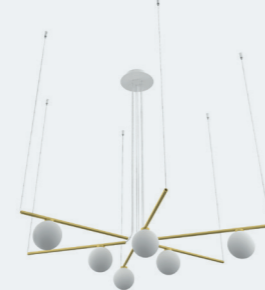
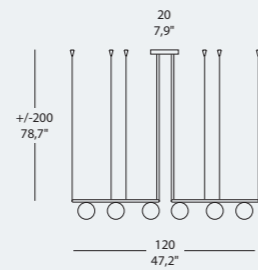

**OUTLIER LA6 INT**  
6 x MAX 4,8W G9 LED   
CE  IP 20 EAC

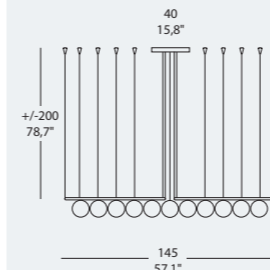

**OUTLIER LA6 ALT**  
6 x MAX 4,8W G9 LED   
CE  IP 20 EAC



**OUTLIER LA12 EXT**  
12 x MAX 4,8W G9 LED   
CE  IP 20 EAC

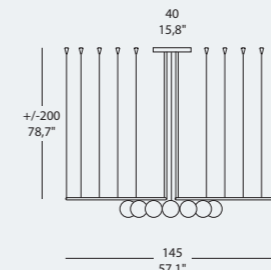

**OUTLIER LA12 INT**  
12 x MAX 4,8W G9 LED   
CE  IP 20 EAC

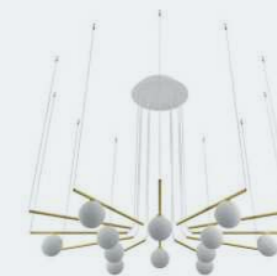
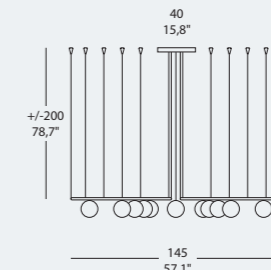

**OUTLIER LA12 ALT**  
12 x MAX 4,8W G9 LED   
CE  IP 20 EAC



# VERSATILE

design\_Morosini

Design ricercato ed essenziale  
per illuminare i tuoi spazi.

Refined and essential design  
to light up your spaces.





Versatile\_SO SMARTY + RO6



Versatile\_SO SMARTY, SO CLASSY + RO5 C60





Versatile\_SO SMARTY + IN1



Versatile\_SO COOL + R03 C40





Versatile\_SO COOL + BI-100

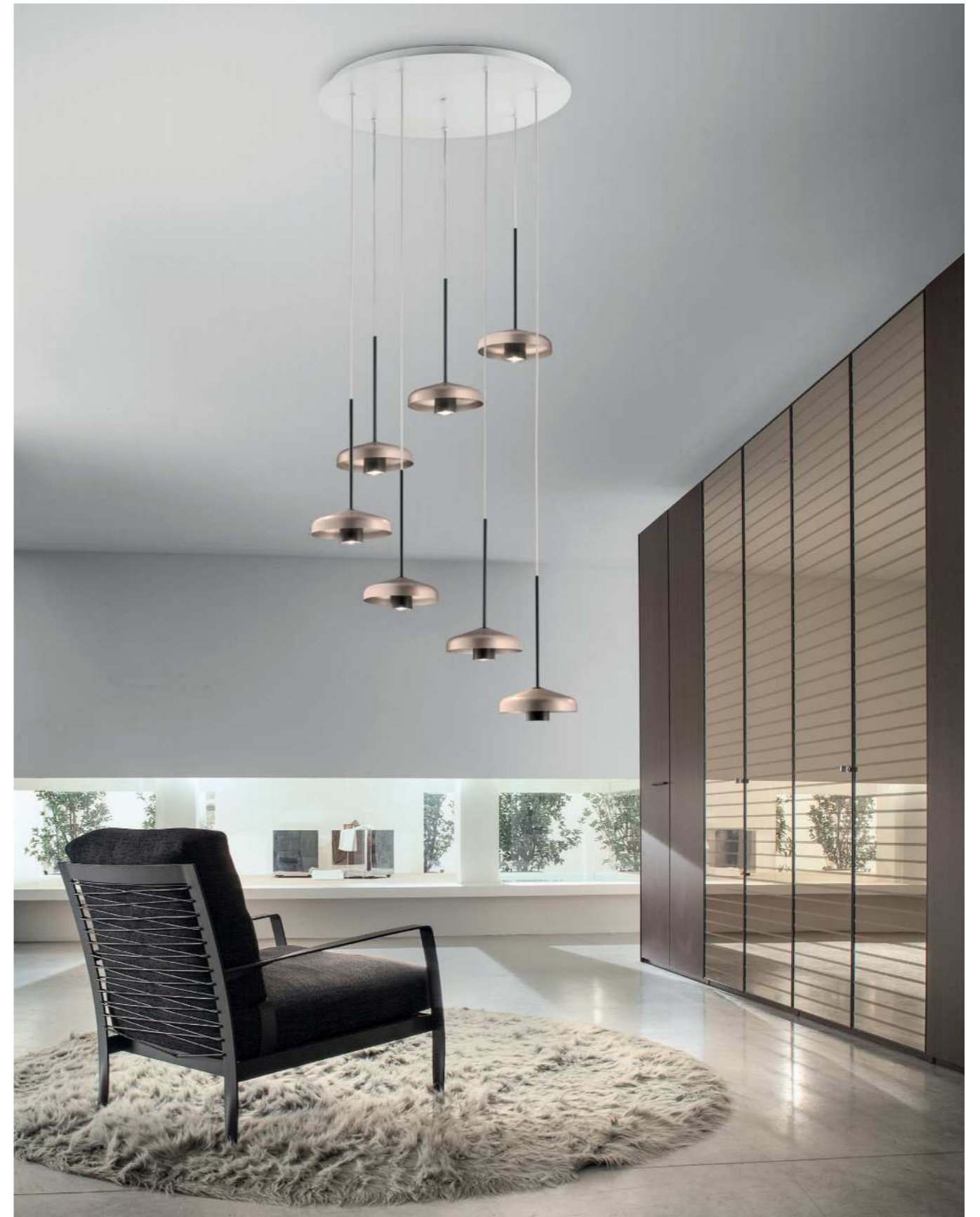

Versatile\_SO CLASSY + R07 C60

# VERSATILE

## \_technical data

Un elemento centrale in alluminio nero, tre diffusori intercambiabili in metallo in tre diversi concept essenziali e ricercati, fanno di Versatile una collezione di lampade per illuminare ogni ambiente, dall'ambito domestico a quello professionale e pubblico. La vasta scelta di rosoni e binari, permette innumerevoli combinazioni di customizzazione per soddisfare ogni esigenza del cliente.

A central element in black aluminum, three interchangeable metal diffusers in three different essential and refined concepts, make Versatile a collection of lamps to illuminate any environment, from the home to the professional and public sphere. The wide choice of ceiling roses and tracks allows countless customization combinations to satisfy every customer need.

Ein zentrales Element aus schwarzem Aluminium, drei austauschbare Metalldiffusoren in drei verschiedenen essentiellen und raffinierten Konzepten machen Versatile zu einer Lampenkollektion zur Beleuchtung jeder Umgebung, vom privaten bis zum professionellen und öffentlichen Bereich. Die große Auswahl an Baldachinen und Schienen ermöglicht unzählige individuelle Kombinationen, um jeden Kundenwunsch zu erfüllen.

Центральный элемент из алюминия, окрашенного в чёрный цвет. Три варианта сменных металлических диффузоров. Такая гибкость делает коллекцию Versatile подходящей для освещения любого помещения, от дома до офисов и общественных пространств. Широкий выбор потолочных оснований и направляющих позволяет создавать разнообразные индивидуальные комбинации, для удовлетворения любых потребностей клиентов.

Trois versions de diffuseurs en métal interchangeables qui partagent une même base; un élément tubulaire central & vertical en aluminium noir équipé d'un bloc optique cylindrique noir. La multitude de possibilités d'équipement fait de Versatile une collection de lampes adaptée pour éclairer des situations variées. De la maison privée aux aménagements professionnels de bureaux ou d'espaces commerciaux. Le large choix des mises en œuvre par rosaces de plafond ou par rails apporte pas mal de solutions.

Un elemento central en aluminio negro, tres difusores de metal intercambiables en tres conceptos diferentes, esenciales y refinados, hacen de Versatile una colección de lámparas para iluminar cualquier ambiente, desde el hogar hasta el ámbito profesional y público. La amplia variedad de florones y pistas permite innumerables combinaciones de personalización para satisfacer las necesidades de cada cliente.

**Rosone/Binario:** bianco opaco.

**Canopy/Track:** matt white.

**Baldachin/Schiene:** weiß matt.

**Rosace plafond/Rail:** blanc mat.

**Florón/Pista:** blanco mate.

**Основание/трек:** матовый белый.

**Struttura:** metallo nero opaco.

**Frame:** matt black metal.

**Struktur:** mattschwarzes metall.

**Estructura:** metal negro mate.

**Структура:** матовый черный металл.

**Diffusore:** metallo nei colori nero opaco con interno oro, bronzo spazzolato, oro spazzolato.

**Diffuser:** metal in matt black with gold interior, brushed bronze, brushed gold.

**Diffusor:** metal in mattschwarz mit goldener Innenseite, gebürstete Bronze, gebürstetes gold.

**Diffuseur:** métal noir mat avec intérieur doré, bronze brossé, or brossé.

**Difusor:** metal en negro mate con interior dorado, bronce cepillado, oro cepillado.

**Рассеиватель:** металл черного матового цвета + золотой внутри, брашированная бронза, брашированное золото.



**NO:** Nero/Oro  
Black/gold



**BR:** Bronzo spazzolato  
Brushed bronze



**OR:** Oro spazzolato  
Brushed gold

### SOSPENSIONI (CAVO STANDARD CM 350). DECENTRAMENTO INCLUSO PER ROSONI RADIALI PENDANT LAMPS (STANDARD CABLE CM 350). OFF CENTRE POSITION INCLUDED FOR RADIAL CANOPIES

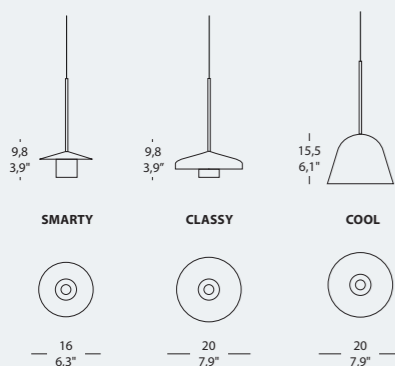

#### VERSATILE SO SMARTY/CLASSY/COOL

1 x MAX 6,9W GU10 LED



### ROSONI + ROSONI RADIALI/CANOPIES + RADIAL CANOPIES

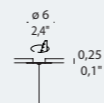

#### VERSATILE IN-1 ROSONE A INCASSO A 1 LUCE 1-LIGHT RECESSED CANOPY

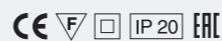

#### VERSATILE RO-1 ROSONE A 1 LUCE 1-LIGHT CANOPY

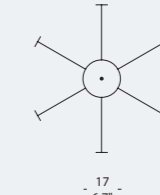
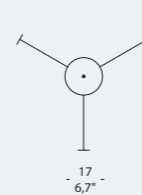
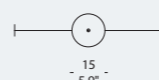
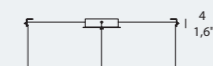
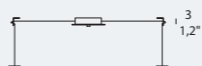

#### VERSATILE RO-2 ROSONE A 2 LUCI 2-LIGHT CANOPY



#### VERSATILE RO-3 ROSONE A 3 LUCI 3-LIGHT CANOPY



#### VERSATILE RO-6 ROSONE A 6 LUCI 6-LIGHT CANOPY

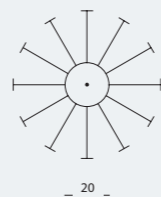
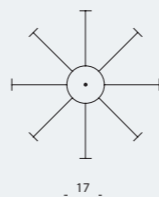
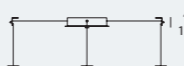
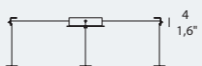

#### VERSATILE RO-8 ROSONE A 8 LUCI 8-LIGHT CANOPY



#### VERSATILE RO-12 ROSONE A 12 LUCI 12-LIGHT CANOPY





## ROSONI CLUSTER/CLUSTER CANOPIES



40  
15,8"

**VERSATILE R03 C40**  
ROSONE A 3 LUCI  
3-LIGHT CANOPY

CE IP 20 EAC



40  
15,8"

**VERSATILE R05 C40**  
ROSONE A 5 LUCI  
5-LIGHT CANOPY

CE IP 20 EAC

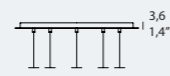

60  
23,6"

**VERSATILE R05 C60**  
ROSONE A 5 LUCI  
5-LIGHT CANOPY

CE IP 20 EAC



60  
23,6"

**VERSATILE R07 C60**  
ROSONE A 7 LUCI  
7-LIGHT CANOPY

CE IP 20 EAC

## BINARI/TRACKS

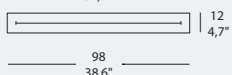

**VERSATILE BI-100**  
BINARIO A 3 LUCI  
3-LIGHT TRACK

CE IP 20 EAC

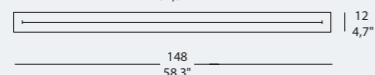
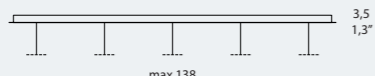

**VERSATILE BI-150**  
BINARIO A 5 LUCI  
5-LIGHT TRACK

CE IP 20 EAC

## ESEMPI DI COMPOSIZIONE/ EXAMPLES OF COMPOSITION

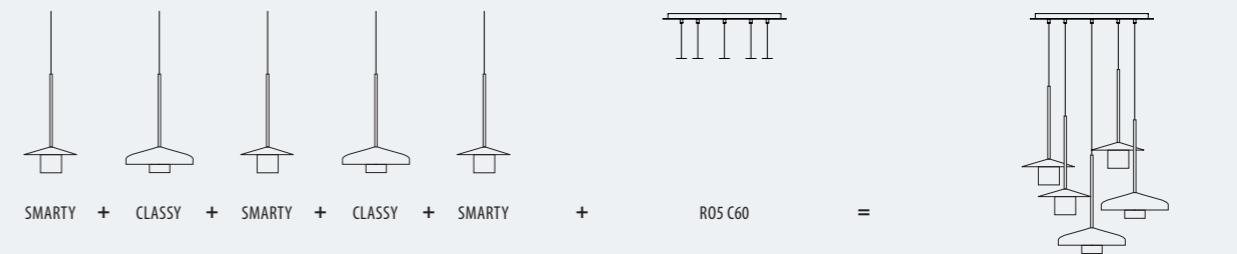
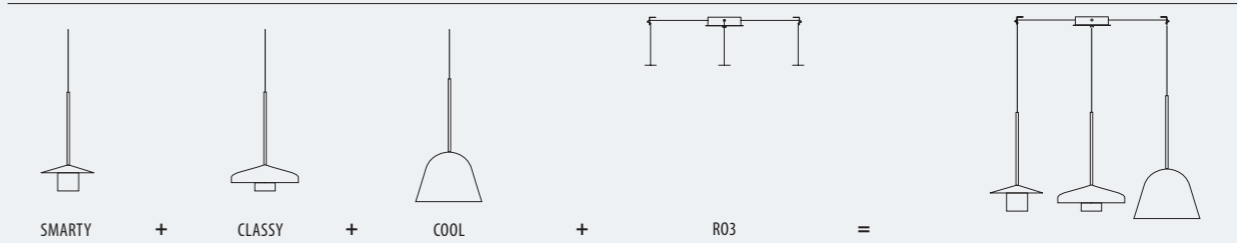
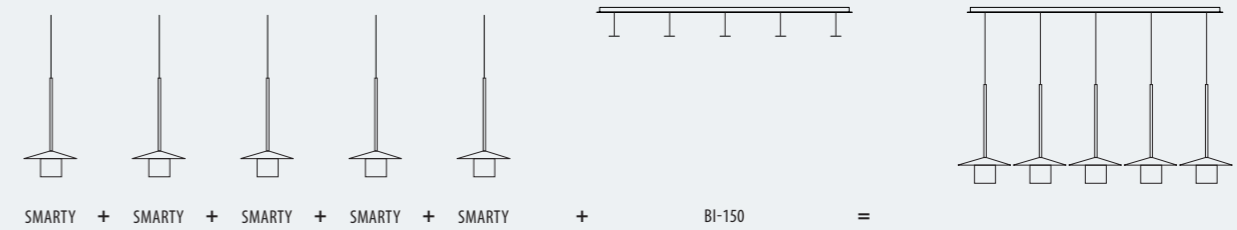

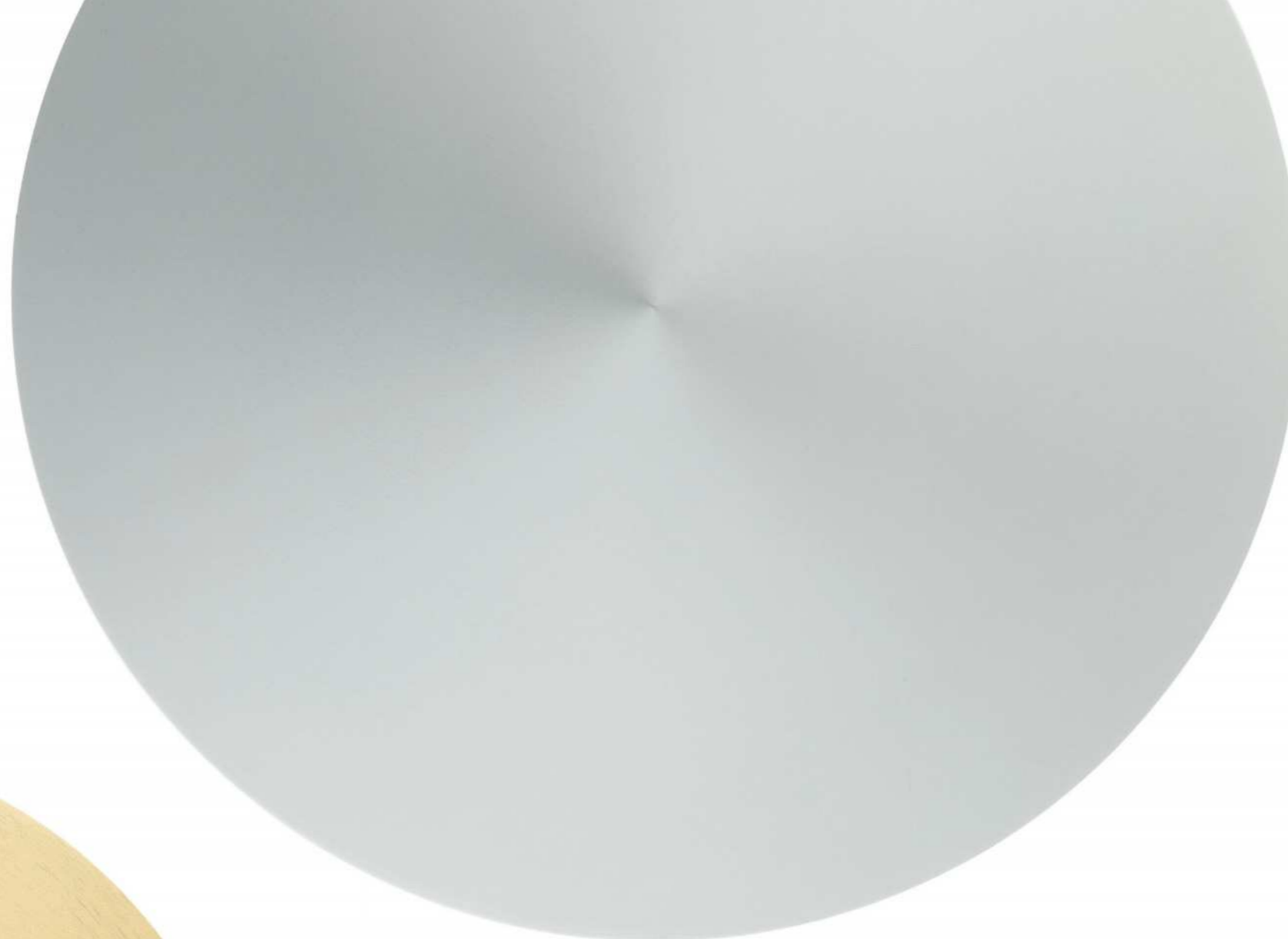

FAYA  
design\_Studio Pang

Elementi di design funzionale.

Functional design fixtures.



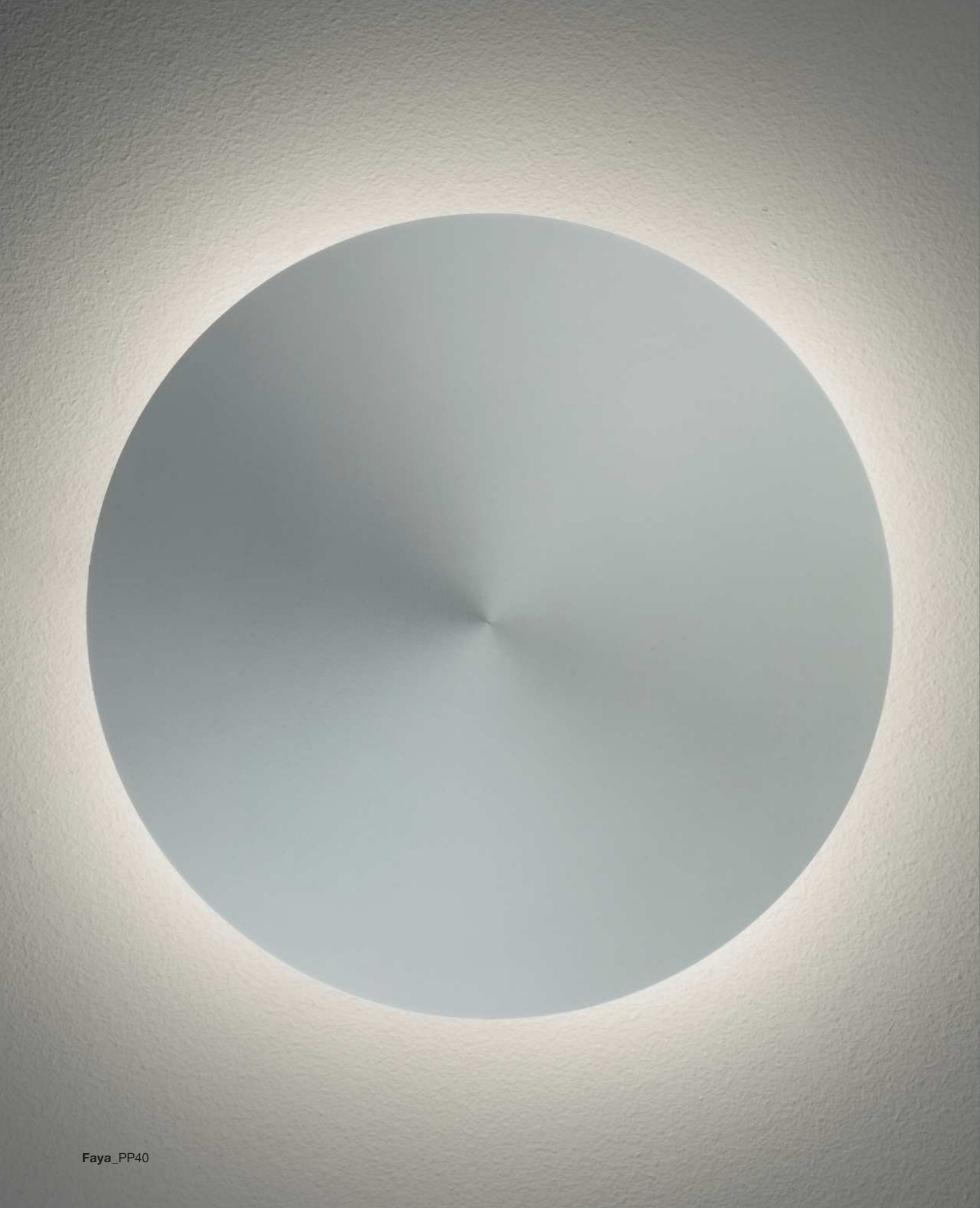

Faya\_PP40



Faya\_PP30





Faya\_PP DUO



Faya\_PP20



VICTORY

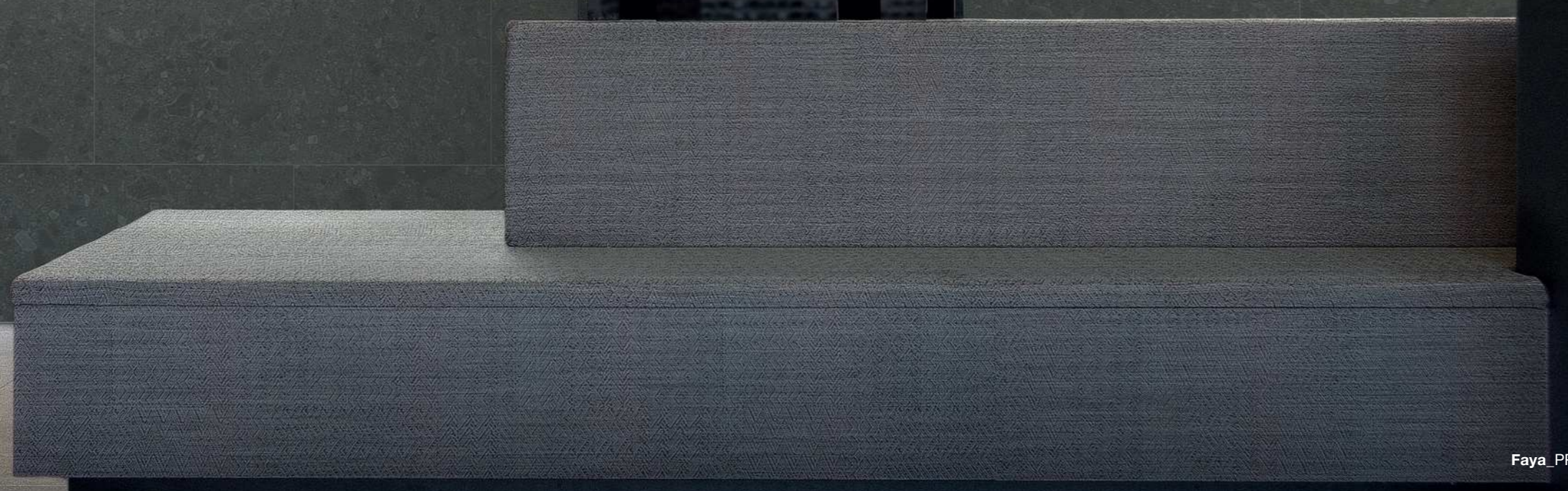
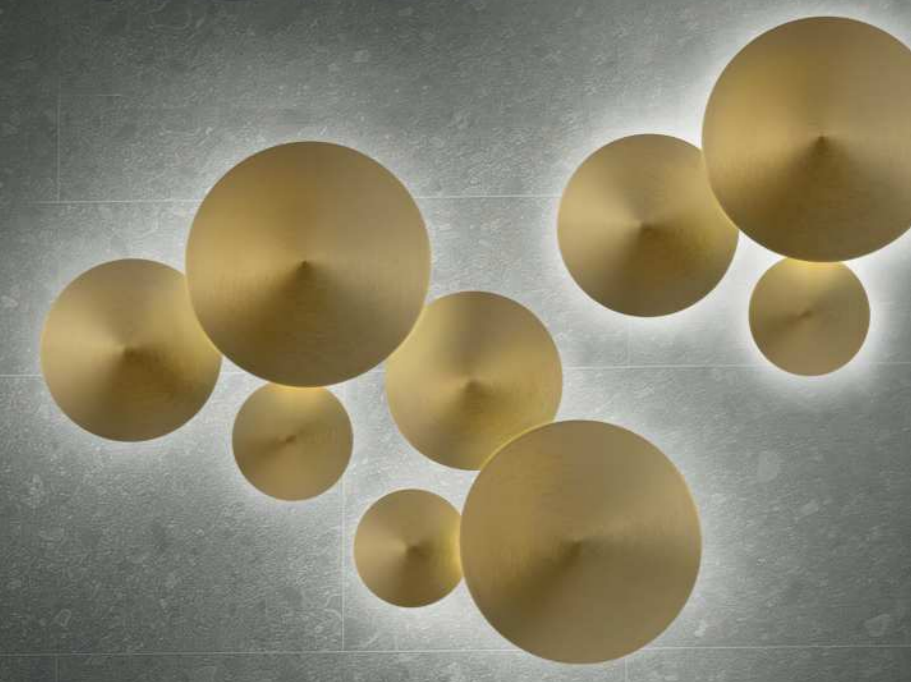
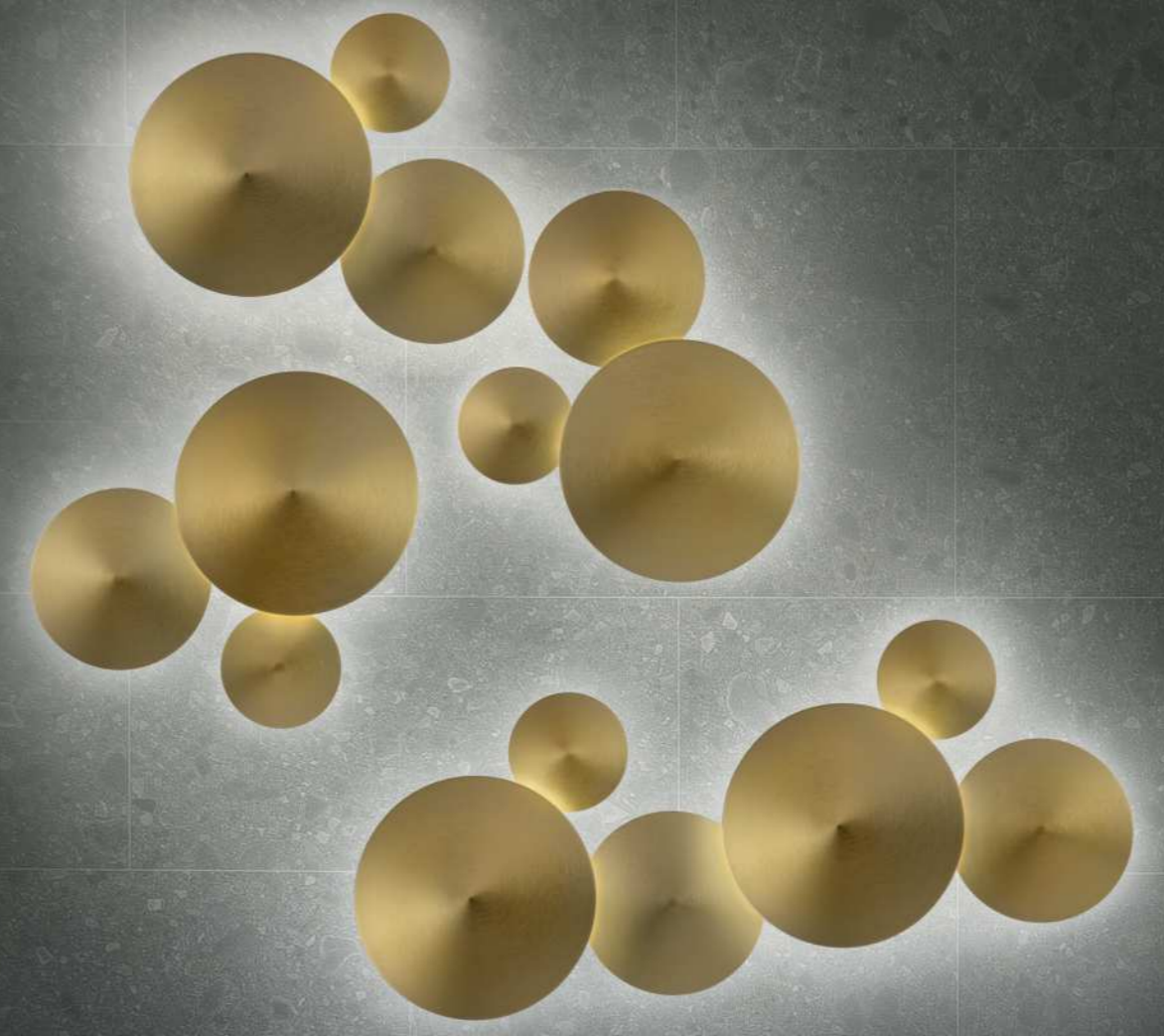



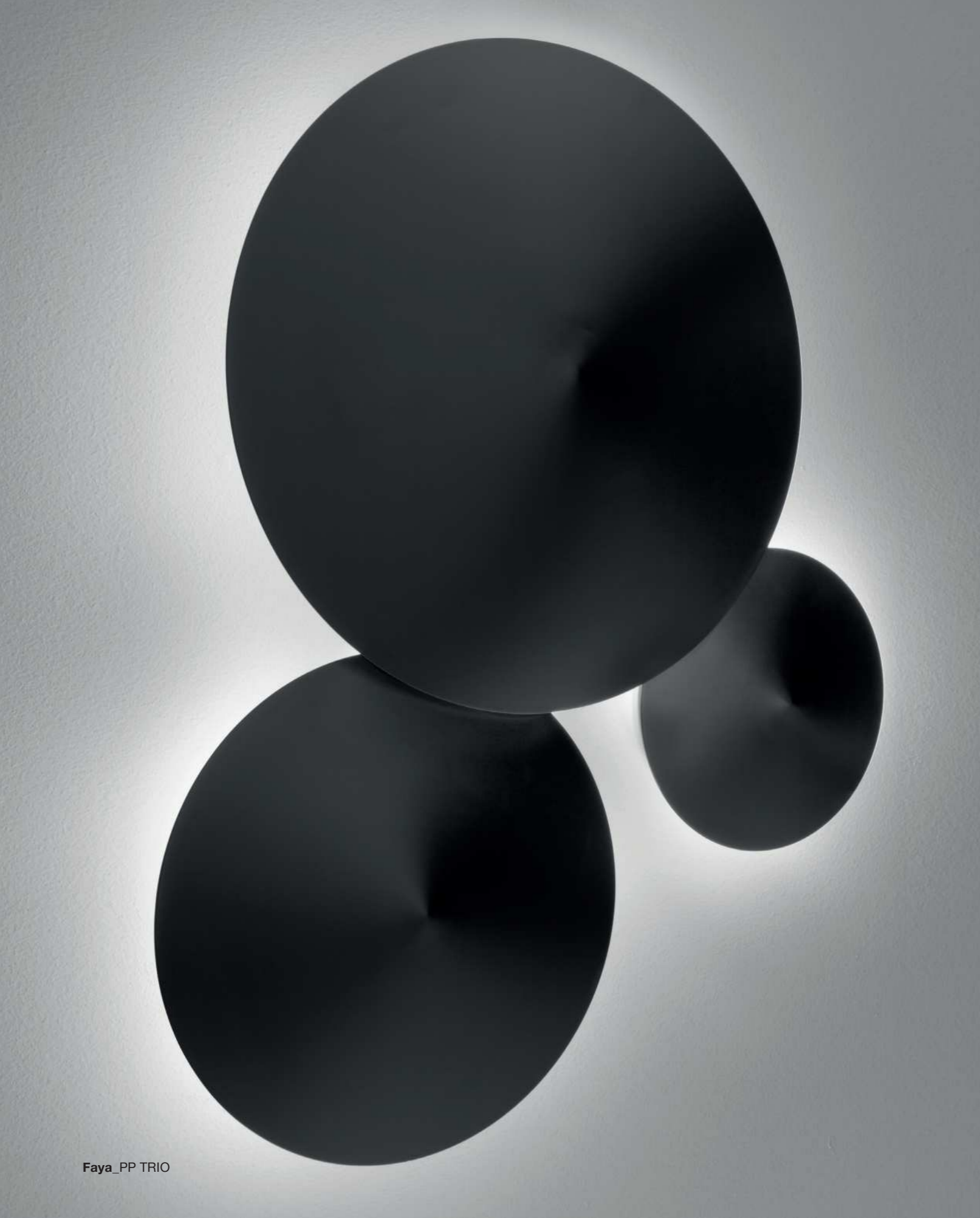

Faya\_PP TRIO

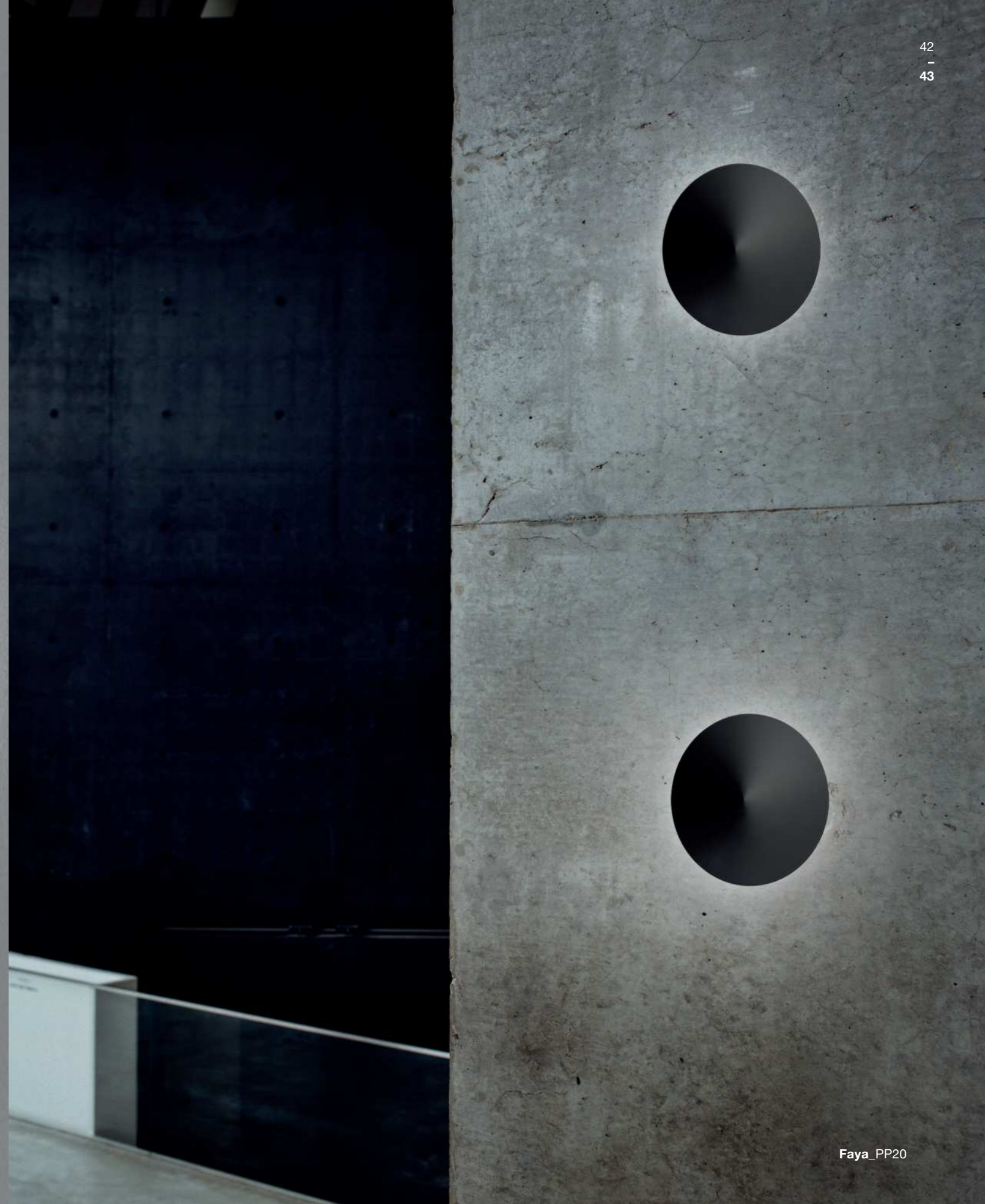

Faya\_PP20



La collezione Faya, disegnata da Studio PANG, è composta da tre lampade da parete di forma conica, realizzate in alluminio tornito disponibili nelle seguenti dimensioni: diametro 200mm, 300mm e 400mm.

Perfetti per essere utilizzati su tutte le pareti, corridoi stretti inclusi, questi tre elementi sono stati studiati affinché possano essere utilizzati in versione singola o in configurazioni di serie a 2 e 3 elementi.

Un progetto che accosta l'impercettibile mutevolezza formale del prodotto a un nuovo concetto di illuminazione che offre la possibilità di generare una piacevole luce indiretta, diffusa e senza abbagliamenti, in svariati contesti applicativi e in totale libertà creativa progettuale.

Non una semplice lampada da parete, ma un sistema di illuminazione altamente versatile capace di trasmettere con delicatezza la propria operatività all'interno dell'ambiente che lo accoglie.

La collection Faya est conçue par Studio PANG et comprend trois lampes murales de forme conique, réalisées en aluminium fraisé disponibles dans les dimensions suivantes : diamètre 200 mm, 300 mm et 400 mm.

Parfaits pour être utilisés sur tous les murs, couloirs étroits compris, ces trois éléments ont été conçus pour qu'ils puissent être utilisés en version simple ou dans les configurations de série « groupées » de 2 et 3 éléments.

Un projet qui associe la flexibilité imperceptible et formelle du produit à un nouveau concept d'éclairage qui offre la possibilité de générer une agréable lumière indirecte, diffuse et non éblouissante, dans d'innombrables situations d'application, et permet également une totale liberté en termes de créativité de conception.

Il ne s'agit pas d'une simple lampe murale mais d'un système d'éclairage hautement versatile capable de transmettre avec délicatesse sa propre opérativité à l'intérieur de l'environnement qui l'accueille.

The Faya collection is designed by Studio PANG and comprises three cone-shaped wall lighting fixtures made of tooled aluminum in the following sizes: diam. 200mm, 300mm and 400mm.

Perfect for any walls – including narrow corridors – these three fixtures have been designed to be used individually or with 2 or 3 elements arranged together.

This project combines superior product flexibility with an innovative lighting concept that produces pleasant indirect light – diffused and glare-free – in countless application situations, and also enables total freedom in terms of design creativity. It's not just a simple wall lighting fixture but a highly versatile system that transmits light that's very kind to the eyes.

La colección Faya, diseñada por Studio PANG, está compuesta por tres lámparas de pared cónicas, fabricadas en aluminio torneado disponibles en los siguientes tamaños: 200 mm de diámetro, 300 mm y 400 mm.

Perfectas para cualquier pared, incluidos los pasillos estrechos, estos tres elementos se han diseñado para usarse individualmente o con 2 o 3 elementos dispuestos juntos.

Un proyecto que combina la mutabilidad formal imperceptible del producto con un nuevo concepto de iluminación que ofrece la posibilidad de generar una luz indirecta agradable, difusa y sin deslumbramiento, en diversos contextos de aplicación y en total libertad creativa de diseño.

Un proyecto que combina la mutabilidad formal imperceptible del producto con un concepto de iluminación innovador que ofrece la posibilidad de generar una luz indirecta agradable, difusa y sin reflejos, en diversos contextos de aplicación y en total libertad creativa de diseño.

No es una simple lámpara de pared, sino un sistema de iluminación altamente versátil y capaz de transmitir delicadamente la luz entorno al ambiente que lo alberga.

Die von Studio PANG entworfene Kollektion Faya besteht aus drei Wandlampen mit einer konischen Form, aus gedrehtem Aluminium und in den folgenden Abmessungen erhältlich: 200 mm, 300 mm und 400 mm. Perfekt zur Anwendung an allen Wänden, einschließlich engen Korridoren; diese drei Elemente wurden entwickelt, um einzeln oder in einer Serienkonfiguration mit 2 oder 3 gemeinsam angebrachten Elementen verwendet zu werden.

Ein Projekt, das die unmerkliche, formelle Veränderlichkeit des Produkts mit einem neuen Beleuchtungskonzept verbindet, das die Möglichkeit bietet, ein angenehmes nicht direktes Licht zu bilden, das verbreitet und nicht blendend ist, in verschiedenen Anwendungskontexten und mit einer absoluten kreativen Projektfreiheit.

Keine einfache Wandlampe, sondern ein sehr vielseitiges Beleuchtungssystem, das sanft seine Funktionalität innerhalb der einhüllenden Umgebung vermittelt.

Коллекция Faya, разработанная Studio PANG, состоит из трех настенных ламп конической формы, созданных из обточенного алюминия, предоставляется следующих размеров : диаметр 200мм, 300мм и 400мм. Прекрасно подходящие для крепления на всех стенах, включая узкие коридоры, эти три элемента были изучены в том числе для использования в единичной версии или в серийной конфигурации , включающей от 2 до 3 элементов, расположенных вместе.

Проект, который максимально приближает неуловимую формальную изменчивость продукта к новой концепции освещения, предлагающей возможность создавать не прямой приятный свет, рассеиваемый и не ослепляющий, в разных концепциях применения и при полной творческой свободе создания проекта.

Непросто настенная лампа, но достаточно универсальная осветительная система, способная деликатно передать собственную оперативность в интерьере размещения.



— 20 —  
7,9"

— 8 —  
3,2"

### FAYA PP 20

3x4,5W 1140 Lm 2700K

Cri>90 Acrich 3 230 Vac 50-60 Hz

3x4,5W 1200 Lm 3000K

Cri>90 Acrich 3 230 Vac 50-60 Hz

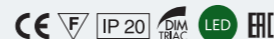

— 30 —  
11,8"

— 10,5 —  
4,1"

### FAYA PP 30

4x4,5W 1520 Lm 2700K

Cri>90 Acrich 3 230 Vac 50-60 Hz

4x4,5W 1600 Lm 3000K

Cri>90 Acrich 3 230 Vac 50-60 Hz

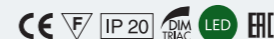

— 40 —  
15,8"

— 13,5 —  
15,8"

### FAYA PP 40

5x4,5W 1900 Lm 2700K

Cri>90 Acrich 3 230 Vac 50-60 Hz

5x4,5W 2000 Lm 3000K

Cri>90 Acrich 3 230 Vac 50-60 Hz

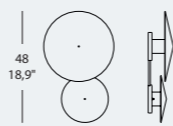
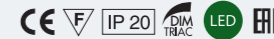

— 30 —  
11,8"

— 10,5 —  
4,1"

### FAYA PP DUO

7x4,5W 2660 Lm 2700K

Cri>90 Acrich 3 230 Vac 50-60 Hz

7x4,5W 2800 Lm 3000K

Cri>90 Acrich 3 230 Vac 50-60 Hz

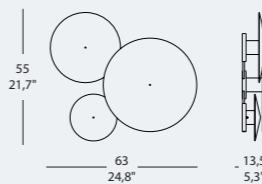
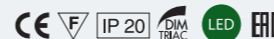

— 63 —  
24,8"

— 13,5 —  
5,3"

### FAYA PP TRIO

12x4,5W 4560 Lm 2700K

Cri>90 Acrich 3 230 Vac 50-60 Hz

12x4,5W 4800 Lm 3000K

Cri>90 Acrich 3 230 Vac 50-60 Hz

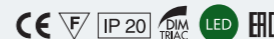

**Struttura:** metallo bianco opaco.

**Frame:** matte white metal.

**Struktur:** Metall, mattweiß.

**Structure:** métal blanc mat.

**Estructura:** metal blanco mate.

**Структура:** белый матовый металл.

**Diffusore:** metallo bianco opaco, nero opaco, oro spazzolato, bronzo spazzolato.

**Diffuser:** matte white metal, matte black, brushed gold, brushed bronze.

**Diffusor:** mattweißes Metall, schwarz matt, Gold gebürstet, Bronze gebürstet.

**Diffuseur:** métal blanc mat, noir mat, or brossé, bronze brossé.

**Difusor:** metal blanco mate, negro mate, oro cepillado, bronce cepillado.

**Рассеиватель:** белый матовый металл, черный матовый металл, брашированное золото, брашированная бронза.

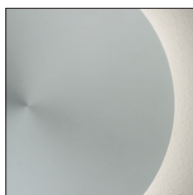

**BI:** Bianco opaco/  
Matte White



**NE:** Nero Opaco/  
Matte Black

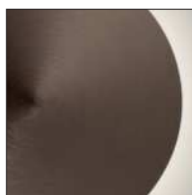

**BR:** Bronzo Spazzolato/  
Brushed Bronze



**OR:** Oro Spazzolato/  
Brushed Gold





# ARCHETYPE

design\_Marco Taietta

Dall'essenza alla linea,  
dall'idea alla luce.

From the essence to the line,  
from the idea to the light.





Archetype\_SO48/SO60



Archetype\_TE A



Archetype\_PL48



Archetype\_PL48/60



## Cos'è il Dim to Warm?

**Dim to Warm è una tecnologia LED che riduce la temperatura del colore di un apparecchio di illuminazione quando è dimmerata, consentendo variazioni graduali nella luce bianca calda (da 1800K a 3000K).**

La tecnologia è stata progettata per replicare la sensazione familiare e naturale della dimmerazione delle lampade ad incandescenza/alogene. La luce, diffusa o d'accento si integra alla perfezione in ambienti residenziali o pubblici quali hotel e ristoranti.

Come il soffice bagliore di una candela accesa, la luce bianca calda crea un senso di intimità e familiarità. I LED Dim to Warm offrono un ambiente confortevole, riproducendo il calore naturale dell'incandescenza dimmerabile, con prestazioni e flessibilità moderne.



## What is Dim to Warm?

**Dim to Warm is a LED technology that reduces the color temperature of a lighting fixture when dimmed, allowing for smooth variations in warm white light (from 1800K to 3000K).**

The technology was designed to replicate the familiar, natural feeling of dimmed incandescent/halogen. This soft or accent lighting is perfect for use in hotels, restaurants, and homes.

Like the soft glow of a lit candle, warm white light creates a sense of intimacy and familiarity. The Dim to Warm LEDs offer comfortable ambience, replicating the natural warmth of incandescence-style dimming, with modern performance and flexibility.

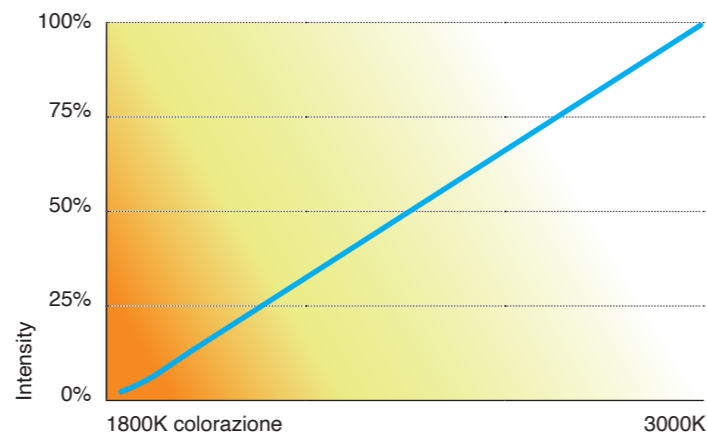

## Come funziona il Dim to Warm?

I **LED Dim to Warm** della collezione Archetype, non richiedono alcun elemento aggiuntivo per la dimmerazione, ad eccezione di un comune dimmer remoto a taglio di fase. Solo la versione da terra è già fornita con dimmer 1/10V.

## How does Dim to Warm work?

The **Dim to Warm LEDs** of Archetype collection do not need any additional unit to dimmer, but an usual remote phase cut dimmer. Just the floor lamp is supplied complete with 1/10 V dimmer.



**1800K**  
intensità / intensity 3%



**2400K**  
intensità / intensity 50%



**3000K**  
intensità / intensity 100%

# ARCHETYPE

## \_technical data

In Archetype sono presenti influenze e rimandi alla Golden Age dell'industrial design italiano legato principalmente agli anni '50 e '60. Il paralume in alluminio è costituito da una geometria atemporale che dialoga con l'elemento-luce inferiore. Elastico l'utilizzo: adatto a spazi domestici, progetti di hotel, uffici e non solo. Nella lampada da terra, alla forte connotazione grafica, si aggiunge un gusto contemporaneo con l'utilizzo della fibra di carbonio per il leggero elemento orizzontale in rapporto con la fisicità del supporto verticale. Un progetto fatto di ricordi che prolunga la memoria dell'osservatore, rendendolo un evergreen. Una lampada che c'era e della quale avevamo ancora bisogno...

Archetype embodies influences and references to the Golden Age of Italian industrial design chiefly linked to the 50s and 60s. The aluminum shade consists of a timeless geometry that communicates with the lower lighting element. Versatility of use: suitable for home interiors, hotel projects, offices and much more. The floor standing version features a strong graphic connotation, where a contemporary taste is added via the use of the carbon fiber for the lightweight arm that harmonizes perfectly with the solidity of the vertical support. This design is linked to memories that extend the observer's recollections, thus making it an evergreen. A lighting fixture that had already been designed and of which we still felt the need for...

Archetype présente des influences et des renvois à la Golden Age de l'industrial design italien essentiellement lié aux années 50 et 60.

L'abat-jour en aluminium est constitué par une géométrie hors du temps qui dialogue avec l'élément-lumière inférieur. L'utilisation est polyvalente: il convient aux espaces domestiques, aux projets d'hôtel, aux bureaux, etc.

Le lampadaire, présente une forte connotation graphique, est complété par un goût contemporain avec l'utilisation de fibre de carbone pour l'élément horizontal léger en rapport avec le physique du support vertical.

Un projet fait de souvenirs qui prolonge la mémoire de l'observateur, en en faisant un evergreen. Une lampe qui existait et de laquelle nous avions encore besoin...

Archetype encarna influencias y referencias a la Edad de Oro del diseño industrial italiano principalmente vinculado a los años 50 y 60.

La pantalla de aluminio consiste en una geometría intemporal que se comunica con el elemento de iluminación inferior. Versatilidad de uso: adecuado para interiores de casas, proyectos de hoteles, oficinas y mucho más.

La lámpara de pie presenta una fuerte connotación gráfica en la que se agrega un sabor contemporáneo mediante el uso de fibra de carbono para el brazo horizontal liviano que se armoniza perfectamente con la solidez del soporte vertical.

Este diseño está vinculado al pasado que amplía la memoria del observador, por lo que es un 'evergreen'. Una lámpara que ya había sido diseñada y que la sentimos aun necesaria...

Bei Archetype liegen Einflüsse und Bezüge auf das Golden Age des italienischen Industrial Designs hauptsächlich der 50er und 60er Jahre vor.

Der Aluminiumlampenschirm besteht einer zeitlosen Geometrie, die mit dem unteren Licht-Element dialogiert. Elastisch ist die Anwendung: Für häusliche Umgebungen, Hotelprojekte, Büros und vieles mehr geeignet.

Der graphischen Eigenschaft der Bodenlampe wird ein kontemporärer Stil durch die Anwendung des Kohlenstoffasers für das leichte waagrechte Element in Verbindung mit dem vertikalen Ständer zugefügt.

Ein aus Erinnerungen bestehendes Projekt, welches das Gedächtnis des Betrachters erweitert und es zu einem Evergreen macht. Eine Lampe, die es gab und die wir noch brauchen...

В коллекции Archetype представлены влияния и веяния Золотого Века итальянского промышленного дизайна, связанного, главным образом, с '50 и '60 г.г.

Алюминиевый абажур воплощен в универсальной геометрии на все времена, которая ведет диалог с нижним световым элементом. Многочисленные возможности применения: подходит для домашних интерьеров, гостиничных проектов, офисных пространств и не только.

В напольной лампе к яркой графической характеристике добавлено влияние современного стиля благодаря использованию углеродистого волокна для легкого горизонтального элемента в пропорции со структурой вертикального суппорта.

Проект, созданный воспоминаниями, который уводит память наблюдателя в прошлое, делая его неувядающим. Лампа, которая была и в которой мы вновь нуждались...

**Struttura:** metallo nelle colorazioni: Bianco, Champagne, Nero, Platino.

**Frame:** metal in the colors: white, black, champagne, platinum.

**Struktur:** Metall in den Farben: Weiß, Schwarz, Champagner, Platinum.

**Structure:** métal dans les teintes: blanc, noir, champagne, platine.

**Estructura:** metal en los colores: blanco, negro, champán, platino.

**Структура:** металл окрашенный в: белый, чёрный, Шампань, Платина.

**Diffusore:** metallo nelle colorazioni: Bianco, Champagne, Nero, Platino.

**Diffuser:** metal in the colors: white, black, champagne, platinum.

**Diffusor:** Metall in den Farben: Weiß, Schwarz, Champagner, Platinum.

**Diffuseur:** métal dans les teintes: blanc, noir, champagne, platine.

**Difusor:** metal en los colores: blanco, negro, champán, platino.

**Рассеиватель:** металл окрашенный в: белый, чёрный, Шампань, Платина.

### DIFFUSORE/DIFFUSERS

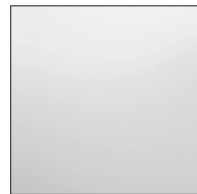

**BI:** Bianco/White

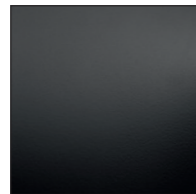

**NE:** Nero/Black



**PL:** Platino/Platinum



**CH:** Champagne

### MONTATURA/FRAME - TE A



**31:** Platino/Platinum

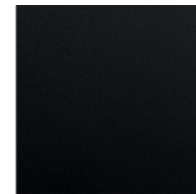

**07:** Nero/Black

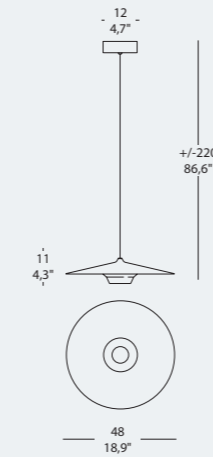

#### ARCHETYPE 50 48

18W Min. 39 Lm - Max 1710 Lm 1800>3000K  
Cri > 95 220-240 Vac 50-60hz

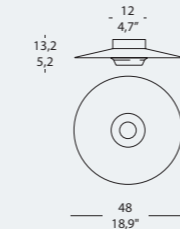

#### ARCHETYPE PL 48

18W Min. 39 Lm - Max 1710 Lm 1800>3000K  
Cri > 95 220-240 Vac 50-60hz

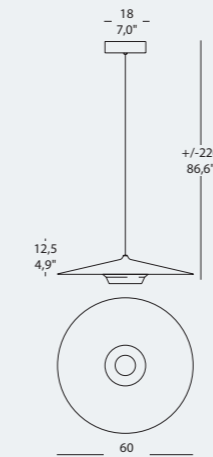

#### ARCHETYPE 50 60

36W Min. 83 Lm - Max 3430 Lm 1800>3000K  
Cri >95 220-240 Vac 50-60hz

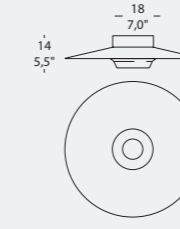

#### ARCHETYPE PL 60

36W Min. 83 Lm - Max 3430 Lm 1800>3000K  
Cri >95 220-240 Vac 50-60hz



### ROSONE/CANOPY - SO 48 - SO 60



**06:** Bianco/White

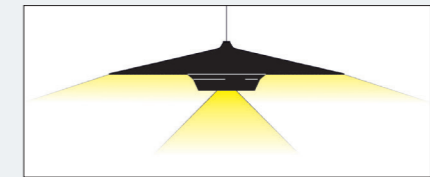

**BIEMISSIONE/DOUBLE EMISSION**

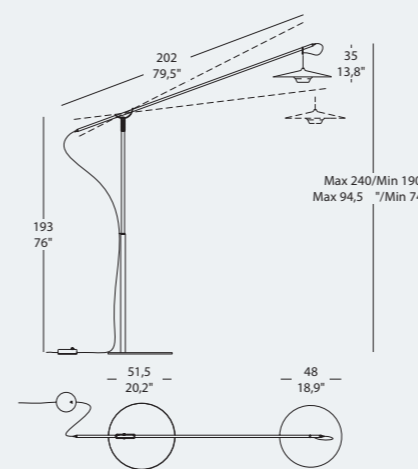

#### ARCHETYPE TE A

18W Min. 39 Lm - Max 1710 Lm 1800>3000K  
Cri > 95 220-240 Vac 50-60hz

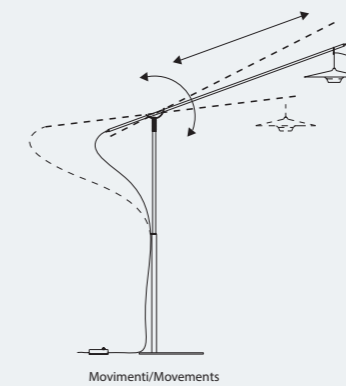

**Fibra di carbonio  
Carbon fiber**





# SANTRAL

design\_Filippo Mambretti

Moderna, morbida, modulare.

Modern, smooth, modular.



Santral\_ esempio di personalizzazione a 24 luci/24 light customized composition example





Santral \_esempio di personalizzazione a 16 luci/ 16 light customized composition example



Santral \_esempio di personalizzazione a 16 luci/16 light customized composition example





Santral\_ esempio di personalizzazione a 24 luci/ 24 light customized composition example



Santral\_ esempio di personalizzazione a 8 luci/ 8 light customized composition example







## \_technical data

Santral rivoluziona l'estetica classica dei lampadari a sospensione. La collezione è altamente personalizzabile nel design grazie ai cavi indipendenti con i quali è possibile creare infinite composizioni sia all'interno dello spazio circoscritto del rosone, sia liberamente all'esterno per mezzo di ancoraggi fissati al soffitto.

Si ottiene così un oggetto d'arredo capace di caratterizzare con formalità e assoluta originalità sia location circoscritte che ambienti spaziosi. Di facile installazione grazie ad un sistema di jack, Santral prevede sorgenti a LED racchiuse in particolari metallucci di forma conica, disponibili anche con diffusore in vetro soffiato satinato che impreziosisce ulteriormente la collezione.

Santral bouleverse l'esthétique classique des lustres à suspension. La collection est hautement personnalisable au niveau du design grâce aux câbles indépendants avec lesquels on peut créer d'infinies compositions à l'intérieur de l'espace circonscrit de la plaque ronde, et librement à l'extérieur au moyen d'ancrages fixés au plafond.

On obtient ainsi un objet de décoration capable de caractériser avec une formalité et une originalité absolue des espaces circonscrits et des pièces spacieuses.

Facile à installer grâce à un système de jacks, Santral prévoit des sources à LED contenues dans des éléments métalliques de forme conique, également fournis avec un diffuseur en verre soufflé satiné qui enrichit ultérieurement la collection.

Santral revolutionizes the classic aesthetics of pendant chandeliers. The collection is highly customizable in design thanks to independent cables with which you can create endless compositions within the ceiling rose of the lamp, but also outside of it, through anchors that are fixed to the ceiling.

The result is a piece of furniture able to give formality and absolute originality to small locations but also to big spaces. Thanks to a system of jacks, Santral is easy to be installed and provides LED sources which are inside of conical metallic elements, also available with a diffuser in blown glass that further enhances the collection.

Santral revoluciona la estética clásica de las arañas.

La colección es perfectamente personalizable en el design gracias a los cables independientes con los cuales es posible crear infinitas composiciones tanto en el interior del espacio circunscrito del rosetón como libremente en el exterior por medio de anclajes fijados al techo.

Se obtiene así un objeto de decoración en condiciones de caracterizar con formalidad y absoluta originalidad tanto lugares circunscritos como ambientes espaciosos.

De fácil instalación gracias a un sistema de jack, Santral prevé fuentes de LED encerradas en detalles metálicos de forma cónica, disponibles incluso con difusor de vidrio soplado satinado que valoriza ulteriormente la colección.

Santral revolutioniert die klassische Ästhetik der Hängelampen.

Die Kollektion ist durch unabhängige Kabel vielseitig im Design personalisierbar. Mit diesen kann man unzählige Kompositionen erstellen, im engen Inneren der Rosette, aber auch bequem aussen durch Deckenbefestigungen. Dadurch entsteht ein Einrichtungsgegenstand, der durch seine Formalität und absolute Originalität in engen Räumen, wie auch geräumigen Umgebungen besticht. Mit einem einfachen Buchsen-Montagesystem ausgestattet, sieht Santral LED-Lichtquellen vor, die in metallische Teile mit konischer Form eingeschlossen sind. Erhältlich auch mit Diffusor aus satiniertem und geblasenem Glas, das die Kollektion nochmals erheblich aufwertet.

Santral производит коренной переворот в классической эстетике подвесных светильников. Коллекция обладает большими возможностями персонализации дизайна, благодаря отдельным проводам, с помощью которых возможно создать бесконечное множество композиций, как внутри пространства, ограниченного потолочной чашей, так и снаружи с помощью потолочных анкеров.

Таким образом, создается предмет обстановки, способный охарактеризовать формально и с абсолютной оригинальностью как ограниченные пространства, так и просторные помещения.

Легко монтируется благодаря системе jack, Santral предусматривает источники света LED, заключенные в металлические элементы конической формы, которые также могут быть предложены с рассеивателем из дутого сатинированного стекла, придающего коллекции дополнительную ценность.

**Struttura:** metallo nero opaco.

**Frame:** matt black metal.

**Struktur:** Metall, mattschwarz.

**Structure:** métal noir mat.

**Estructura:** metal negro opaco.

**Структура:** металл, выполняется в черном матовом цвете.

**Diffusore:** vetro satinato.

**Diffuser:** satin glass.

**Diffusor:** Satiniertes Glas.

**Diffuseur:** verre satiné.

**Difusor:** vidrio satinado.

**Рассеиватель:** Сатинированное стекло.

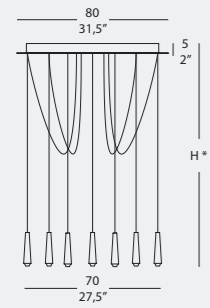

### SANTRAL LA 8 GLASS\_S

**Cavo/cable standard cm 200/78,8"**

8 x 2,9W 3680 Lm 3000K Cri>80 220/240V

8 x 2,9W 3440 Lm 2700K Cri>80 220/240V **LED**

### SANTRAL LA 8 GLASS\_S DIM PD

8 x 2,9W 3680 Lm 3000K Cri>80 220/240V

8 x 2,9W 3440 Lm 2700K Cri>80 220/240V

con driver dimmerabile push/with push dimmable driver 220/240V **LED**

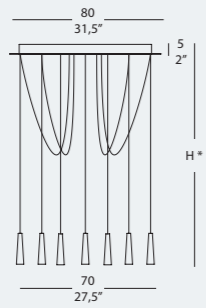

### SANTRAL LA 8\_S

**Cavo/cable standard cm 200/78,8"**

8 x 2,9W 3680 Lm 3000K Cri>80 220/240V

8 x 2,9W 3440 Lm 2700K Cri>80 220/240V **LED**

### SANTRAL LA 8\_S DIM PD

8 x 2,9W 3680 Lm 3000K Cri>80 220/240V

8 x 2,9W 3440 Lm 2700K Cri>80 220/240V

con driver dimmerabile push/with push dimmable driver 220/240V **LED**

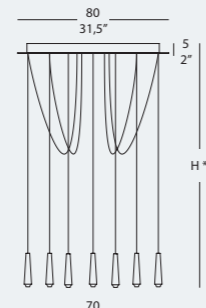

### SANTRAL LA 8 GLASS\_L

**Cavo/cable standard cm 280/110,2"**

8 x 2,9W 3680 Lm 3000K Cri>80 220/240V

8 x 2,9W 3440 Lm 2700K Cri>80 220/240V **LED**

### SANTRAL LA 8 GLASS\_L DIM PD

8 x 2,9W 3680 Lm 3000K Cri>80 220/240V

8 x 2,9W 3440 Lm 2700K Cri>80 220/240V

con driver dimmerabile push/with push dimmable driver 220/240V **LED**

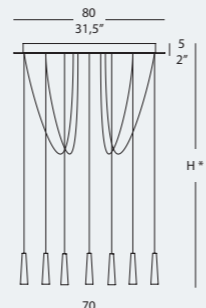

### SANTRAL LA 8\_L

**Cavo/cable standard cm 280/110,2"**

8 x 2,9W 3680 Lm 3000K Cri>80 220/240V

8 x 2,9W 3440 Lm 2700K Cri>80 220/240V **LED**

### SANTRAL LA 8\_L DIM PD

8 x 2,9W 3680 Lm 3000K Cri>80 220/240V

8 x 2,9W 3440 Lm 2700K Cri>80 220/240V

con driver dimmerabile push/with push dimmable driver 220/240V **LED**

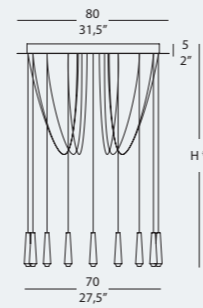

### SANTRAL LA 16 GLASS\_S

**Cavo/cable standard cm 200/78,8"**

16 x 2,9W 7360 Lm 3000K Cri>80 220/240V

16 x 2,9W 6880 Lm 2700K Cri>80 220/240V **LED**

### SANTRAL LA 16 GLASS\_S DIM PD

16 x 2,9W 7360 Lm 3000K Cri>80 220/240V

16 x 2,9W 6880 Lm 2700K Cri>80 220/240V

con driver dimmerabile push/with push dimmable driver 220/240V **LED**

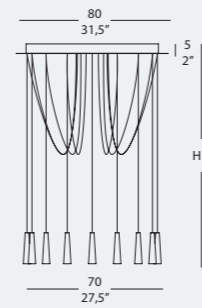

### SANTRAL LA 16\_S DIM PD

**Cavo/cable standard cm 200/78,8"**

16 x 2,9W 7360 Lm 3000K Cri>80 220/240V

16 x 2,9W 6880 Lm 2700K Cri>80 220/240V **LED**

### SANTRAL LA 16\_S DIM PD

16 x 2,9W 7360 Lm 3000K Cri>80 220/240V

16 x 2,9W 6880 Lm 2700K Cri>80 220/240V

con driver dimmerabile push/with push dimmable driver 220/240V **LED**

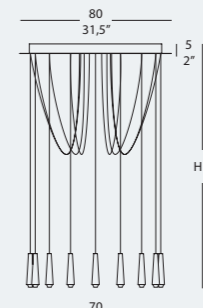

### SANTRAL LA 16 GLASS\_L

**Cavo/cable standard cm 280/110,2"**

16 x 2,9W 7360 Lm 3000K Cri>80 220/240V

16 x 2,9W 6880 Lm 2700K Cri>80 220/240V **LED**

### SANTRAL LA 16 GLASS\_L DIM PD

16 x 2,9W 7360 Lm 3000K Cri>80 220/240V

16 x 2,9W 6880 Lm 2700K Cri>80 220/240V

con driver dimmerabile push/with push dimmable driver 220/240V **LED**

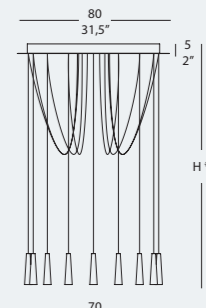

### SANTRAL LA 16\_L

**Cavo/cable standard cm 280/110,2"**

16 x 2,9W 7360 Lm 3000K Cri>80 220/240V

16 x 2,9W 6880 Lm 2700K Cri>80 220/240V **LED**

### SANTRAL LA 16\_L DIM PD

16 x 2,9W 7360 Lm 3000K Cri>80 220/240V

16 x 2,9W 6880 Lm 2700K Cri>80 220/240V

con driver dimmerabile push/with push dimmable driver 220/240V **LED**

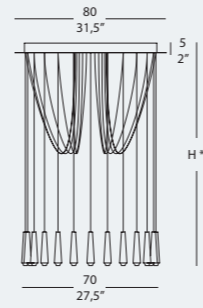

### SANTRAL LA 24 GLASS\_S

**Cavo/cable standard cm 200/78,8"**

24 x 2,9W 11040 Lm 3000K Cri>80 220/240V

24 x 2,9W 10320 Lm 2700K Cri>80 220/240V **LED**

### SANTRAL LA 24 GLASS\_S DIM PD

24 x 2,9W 11040 Lm 3000K Cri>80 220/240V

24 x 2,9W 10320 Lm 2700K Cri>80 220/240V

con driver dimmerabile push/with push dimmable driver 220/240V **LED**

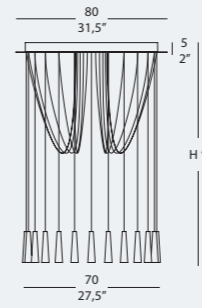

### SANTRAL LA 24\_S

**Cavo/cable standard cm 200/78,8"**

24 x 2,9W 11040 Lm 3000K Cri>80 220/240V

24 x 2,9W 10320 Lm 2700K Cri>80 220/240V **LED**

### SANTRAL LA 24\_S DIM PD

24 x 2,9W 11040 Lm 3000K Cri>80 220/240V

24 x 2,9W 10320 Lm 2700K Cri>80 220/240V

con driver dimmerabile push/with push dimmable driver 220/240V **LED**

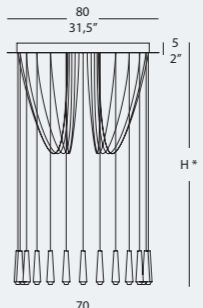

### SANTRAL LA 24 GLASS\_L

**Cavo/cable standard cm 280/110,2"**

24 x 2,9W 11040 Lm 3000K Cri>80 220/240V

24 x 2,9W 10320 Lm 2700K Cri>80 220/240V **LED**

### SANTRAL LA 24 GLASS\_L DIM PD

24 x 2,9W 11040 Lm 3000K Cri>80 220/240V

24 x 2,9W 10320 Lm 2700K Cri>80 220/240V

con driver dimmerabile push/with push dimmable driver 220/240V **LED**

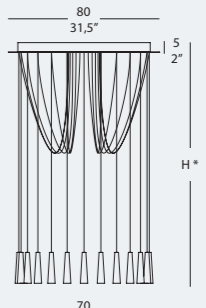

### SANTRAL LA 24\_L

**Cavo/cable standard cm 280/110,2"**

24 x 2,9W 11040 Lm 3000K Cri>80 220/240V

24 x 2,9W 10320 Lm 2700K Cri>80 220/240V **LED**

### SANTRAL LA 24\_L DIM PD

24 x 2,9W 11040 Lm 3000K Cri>80 220/240V

24 x 2,9W 10320 Lm 2700K Cri>80 220/240V

con driver dimmerabile push/with push dimmable driver 220/240V **LED**



H\*  
Altezza variabile/Variable height  
Höhenverstellbar/Hauteur variable  
Altura variable/меняющаяся высота

SU RICHIESTA È POSSIBILE AVERE ANCHE DRIVER DIMMERABILE 1/10V O DALI  
1/10V AND DALI DIMMABLE DRIVER CAN BE SUPPLIED BY REQUEST





# MIKADO

design\_Filippo Mambretti



**1° PREMIO  
WINNER**

Intreccio di segni evocativo  
come un ideogramma.

An evocative weave of signs,  
like an ideogram.



Mikado\_LA 6



Mikado\_S3L





Mikado\_LA 12



Mikado\_S5L GLASS







Mikado\_LA 12 GLASS



Mikado\_IN1 GLASS







## \_technical data

Riletatura in chiave destrutturata dell'estetica classica dei lampadari a sospensione. Mikado è un intreccio di linee e piani che producono un fluttuante movimento nello spazio generando figure geometriche semplici o complesse.

Le varie versioni a sospensione, lineari o circolari, permettono diversi gradi di personalizzazione ed elaborazione della struttura: sobria e minimalista o complessa ed eccentrica grazie alla sovrapposizione di piani ad altezze asimmetriche.

Le sorgenti a LED sono racchiuse in particolari metallici di forma conica, disponibili anche con diffusore in vetro soffiato satinato che impreziosisce ulteriormente la collezione.

A deconstructive reinterpretation of the classical aesthetics of pendant chandeliers. Mikado is a mixture of lines and planes that produce a fluctuating movement in space creating simple or complex geometric figures.

The various linear or circular pendant versions allow different degrees of customization and elaboration of the frame: simple and minimalist or complex and eccentric thanks to the overlapping planes at asymmetric heights. The LED sources are enclosed inside of conical metallic elements, available also with satin blown glass diffuser, further enriching the collection.

Eine unstrukturierte Neuinterpretation der klassischen Ästhetik von Hängelampen. Mikado ist ein Geflecht aus Linien und Ebenen das schwankende Bewegungen im Raum produziert, indem es einfache und komplexe Geometrie-Figuren erzeugt. Die verschiedenen Ausführungen der Abhängungen, linear oder kreisförmig, ermöglichen diverse Möglichkeiten der Personalisierung und Ausarbeitung der Struktur: schlicht und minimalistisch, oder komplex und exzentrisch, dank der Überlappung der Ebenen in asymmetrischen Abständen. Die LED-Lichtquellen sind eingeschlossen in metallische Teile mit konischer Form. Erhältlich auch mit Diffusor aus satiniertem und geblasenen Glas, das die Kollektion nochmals erheblich aufwertet.

Новая интерпретация в деструктивном ключе классической эстетики подвесных светильников.

Mikado – это переплетение линий и плоскостей, которые вызывает колышущее движение в пространстве, создавая простые и сложные геометрические фигуры.

Разнообразные версии подвесного светильника, как с линейным, так и с круговым расположением, позволяют разную степень персонализации и отделки структуры: строгую и минималистичную или, благодаря асимметричному расположению плоскостей по высоте, сложную и эксцентричную. Источники LED заключены в металлические элементы конической формы, которые также могут быть предложены с рассеивателем из дутого сатинированного стекла, придающего коллекции дополнительную ценность.

Relecture sous un jour déstructuré de l'esthétique classique des lustres à suspension. Mikado est un enchevêtrement de lignes et de plans qui produisent un mouvement fluctuant dans l'espace générant des figures géométriques simples ou complexes.

Les différentes versions à suspension, linéaires ou circulaires, permettent différents degrés de personnalisation et d'élaboration de la structure : sobre et minimaliste ou complexe et excentrique grâce à la superposition de plans à des hauteurs asymétriques.

Les sources à LED sont contenues dans des éléments métalliques de forme conique, également fournis avec un diffuseur en verre soufflé satiné qui enrichit ultérieurement la collection.

Relectura en clave descompuesta de la estética clásica de las lucernas suspendidas, Mikado es un enredo de líneas y planos que producen un movimiento oscilante en el espacio generando figuras geométricas simples y complejas.

Las varias versiones a suspensión, lineales o circulares, permiten varios grados de personalización y elaboración de la estructura: sobria y minimalista o compleja y excéntrica gracias a la sobreposición de planos de alturas asimétricas.

Las fuentes de LED están encerradas en detalles metálicos de forma cónica, disponibles incluso con difusor de vidrio soplado satinado que valoriza ulteriormente la colección.

**Struttura:** metallo nero opaco.

**Frame:** matt black metal.

**Struktur:** Metall, mattschwarz.

**Structure:** métal noir mat.

**Estructura:** metal negro opaco.

**Структура:** металл, выполняется в черном матовом цвете.

**Diffusore:** vetro satinato.

**Diffuser:** satin glass.

**Diffusor:** Satiniertes Glas.

**Diffuseur:** verre satiné.

**Difusor:** vidrio satinado.

**Рассеиватель:** Сатинированное стекло.

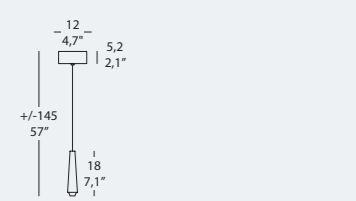

### MIKADO S0 1 GLASS\_S

1 x 2,9W 460 Lm 3000K Cri>80 220/240V

1 x 2,9W 430 Lm 2700K Cri>80 220/240V **LED**

**CE** **F** **IP 20** **ERC**

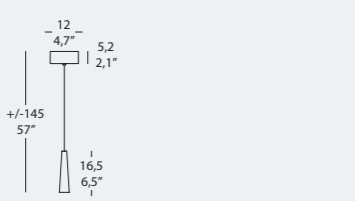

### MIKADO S0 1\_S

1 x 2,9W 460 Lm 3000K Cri>80 220/240V

1 x 2,9W 430 Lm 2700K Cri>80 220/240V **LED**

**CE** **F** **IP 20** **ERC**



### MIKADO IN 1 GLASS\_S

1 x 2,9W 460 Lm 3000K Cri>80 220/240V

1 x 2,9W 430 Lm 2700K Cri>80 220/240V **LED**

**CE** **F** **IP 20** **ERC**

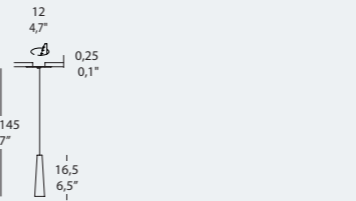

### MIKADO IN 1\_S

1 x 2,9W 460 Lm 3000K Cri>80 220/240V

1 x 2,9W 430 Lm 2700K Cri>80 220/240V **LED**

**CE** **F** **IP 20** **ERC**

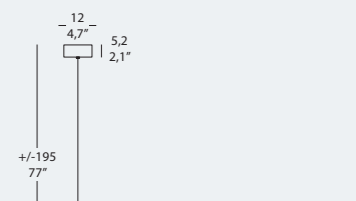

### MIKADO S0 1 GLASS\_L

1 x 2,9W 460 Lm 3000K Cri>80 220/240V

1 x 2,9W 430 Lm 2700K Cri>80 220/240V **LED**

**CE** **F** **IP 20** **ERC**

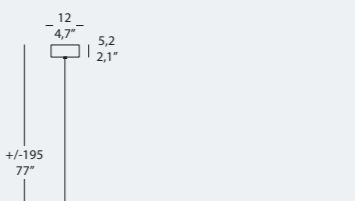

### MIKADO S0 1\_L

1 x 2,9W 460 Lm 3000K Cri>80 220/240V

1 x 2,9W 430 Lm 2700K Cri>80 220/240V **LED**

**CE** **F** **IP 20** **ERC**

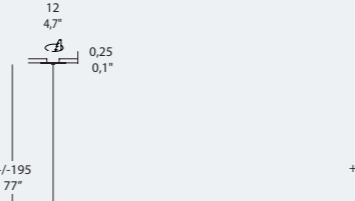

### MIKADO IN 1 GLASS\_L

1 x 2,9W 460 Lm 3000K Cri>80 220/240V

1 x 2,9W 430 Lm 2700K Cri>80 220/240V **LED**

**CE** **F** **IP 20** **ERC**

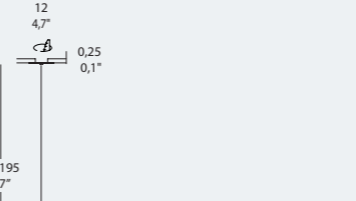

### MIKADO IN 1\_L

1 x 2,9W 460 Lm 3000K Cri>80 220/240V

1 x 2,9W 430 Lm 2700K Cri>80 220/240V **LED**

**CE** **F** **IP 20** **ERC**

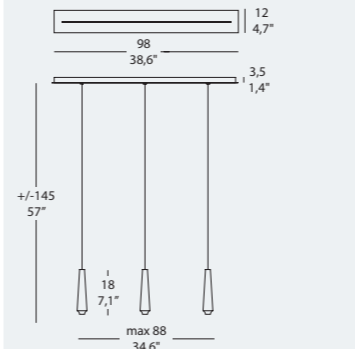

### MIKADO S3L GLASS\_S

3 x 2,9W 1380 Lm 3000K Cri>80 220/240V

3 x 2,9W 1290 Lm 2700K Cri>80 220/240V **LED**

### MIKADO S3L GLASS\_S DIM PD

3 x 2,9W 1380 Lm 3000K Cri>80 220/240V

3 x 2,9W 1290 Lm 2700K Cri>80 220/240V

con driver dimmerabile push/with push dimmable driver 220/240V **LED**

**CE** **F** **IP 20** **ERC**

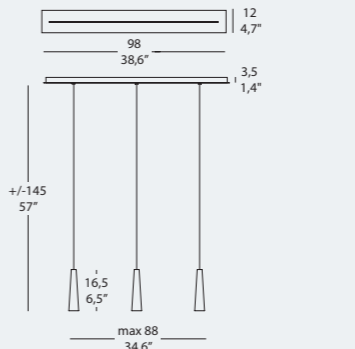

### MIKADO S3L\_S

3 x 2,9W 1380 Lm 3000K Cri>80 220/240V

3 x 2,9W 1290 Lm 2700K Cri>80 220/240V **LED**

### MIKADO S3L\_S DIM PD

3 x 2,9W 1380 Lm 3000K Cri>80 220/240V

3 x 2,9W 1290 Lm 2700K Cri>80 220/240V

con driver dimmerabile push/with push dimmable driver 220/240V **LED**

**CE** **F** **IP 20** **ERC**

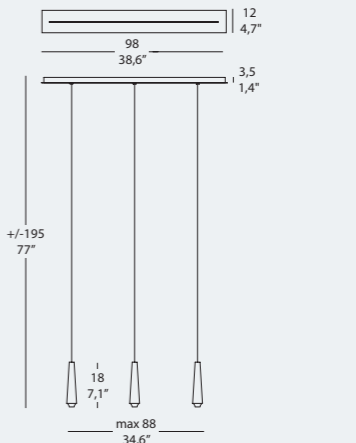

### MIKADO S3L GLASS\_L

3 x 2,9W 1380 Lm 3000K Cri>80 220/240V

3 x 2,9W 1290 Lm 2700K Cri>80 220/240V **LED**

### MIKADO S3L GLASS\_L DIM PD

3 x 2,9W 1380 Lm 3000K Cri>80 220/240V

3 x 2,9W 1290 Lm 2700K Cri>80 220/240V

con driver dimmerabile push/with push dimmable driver 220/240V **LED**

**CE** **F** **IP 20** **ERC**

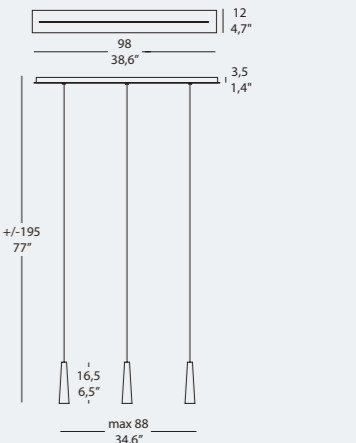

### MIKADO S3L\_L

3 x 2,9W 1380 Lm 3000K Cri>80 220/240V

3 x 2,9W 1290 Lm 2700K Cri>80 220/240V **LED**

### MIKADO S3L\_L DIM PD

3 x 2,9W 1380 Lm 3000K Cri>80 220/240V

3 x 2,9W 1290 Lm 2700K Cri>80 220/240V

con driver dimmerabile push/with push dimmable driver 220/240V **LED**

**CE** **F** **IP 20** **ERC**

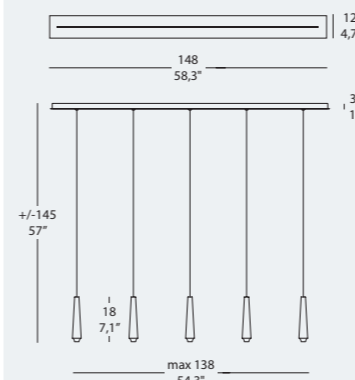

### MIKADO SSL GLASS\_S

5 x 2,9W 2300 Lm 3000K Cri>80 220/240V

5 x 2,9W 2150 Lm 2700K Cri>80 220/240V **LED**

### MIKADO SSL GLASS\_S DIM PD

5 x 2,9W 2300 Lm 3000K Cri>80 220/240V

5 x 2,9W 2150 Lm 2700K Cri>80 220/240V

con driver dimmerabile push/with push dimmable driver 220/240V **LED**

**CE** **F** **IP 20** **ERC**

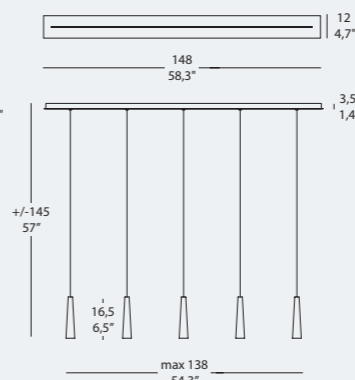

### MIKADO SSL\_S

5 x 2,9W 2300 Lm 3000K Cri>80 220/240V

5 x 2,9W 2150 Lm 2700K Cri>80 220/240V **LED**

### MIKADO SSL\_S DIM PD

5 x 2,9W 2300 Lm 3000K Cri>80 220/240V

5 x 2,9W 2150 Lm 2700K Cri>80 220/240V

con driver dimmerabile push/with push dimmable driver 220/240V **LED**

**CE** **F** **IP 20** **ERC**

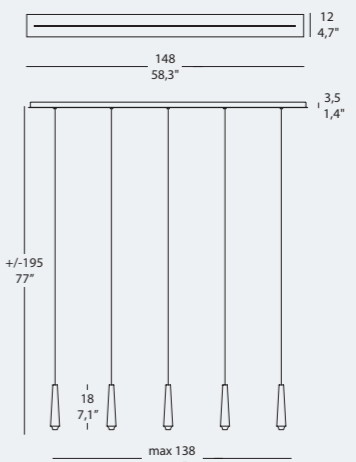

### MIKADO SSL GLASS\_L

5 x 2,9W 2300 Lm 3000K Cri>80 220/240V

5 x 2,9W 2150 Lm 2700K Cri>80 220/240V **LED**

### MIKADO SSL GLASS\_L DIM PD

5 x 2,9W 2300 Lm 3000K Cri>80 220/240V

5 x 2,9W 2150 Lm 2700K Cri>80 220/240V

con driver dimmerabile push/with push dimmable driver 220/240V **LED**

**CE** **F** **IP 20** **ERC**

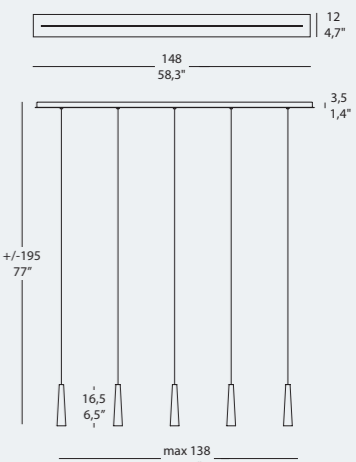

### MIKADO SSL\_L

5 x 2,9W 2300 Lm 3000K Cri>80 220/240V

5 x 2,9W 2150 Lm 2700K Cri>80 220/240V **LED**

### MIKADO SSL\_L DIM PD

5 x 2,9W 2300 Lm 3000K Cri>80 220/240V

5 x 2,9W 2150 Lm 2700K Cri>80 220/240V

con driver dimmerabile push/with push dimmable driver 220/240V **LED**

**CE** **F** **IP 20** **ERC**

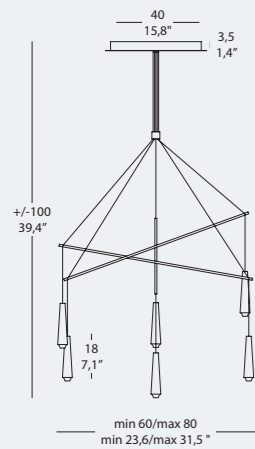

### MIKADO LA 6 GLASS\_S

6 x 2,9W 2760 Lm 3000K Cri>80 220/240V  
6 x 2,9W 2580 Lm 2700K Cri>80 220/240V **LED**

### MIKADO LA 6 GLASS\_S DIM PD

6 x 2,9W 2760 Lm 3000K Cri>80 220/240V  
6 x 2,9W 2580 Lm 2700K Cri>80 220/240V  
con driver dimmerabile push/with push dimmable driver 220/240V **LED**

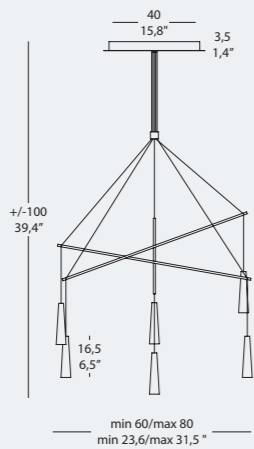

### MIKADO LA 6\_S

6 x 2,9W 2760 Lm 3000K Cri>80 220/240V  
6 x 2,9W 2580 Lm 2700K Cri>80 220/240V **LED**

### MIKADO LA 6\_S DIM PD

6 x 2,9W 2760 Lm 3000K Cri>80 220/240V  
6 x 2,9W 2580 Lm 2700K Cri>80 220/240V  
con driver dimmerabile push/with push dimmable driver 220/240V **LED**

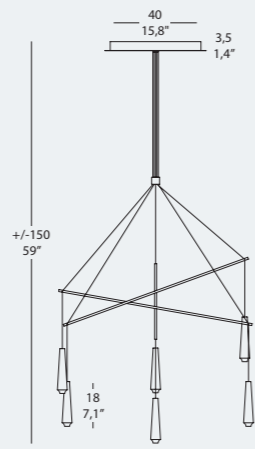
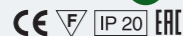

### MIKADO LA 6 GLASS\_L

6 x 2,9W 2760 Lm 3000K Cri>80 220/240V  
6 x 2,9W 2580 Lm 2700K Cri>80 220/240V **LED**

### MIKADO LA 6 GLASS\_L DIM PD

6 x 2,9W 2760 Lm 3000K Cri>80 220/240V  
6 x 2,9W 2580 Lm 2700K Cri>80 220/240V  
con driver dimmerabile push/with push dimmable driver 220/240V **LED**

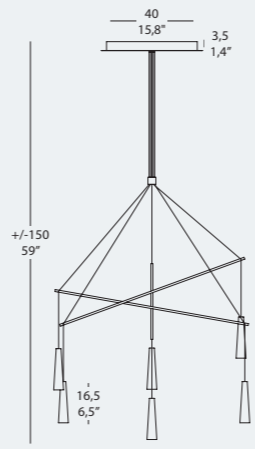

### MIKADO LA 6\_L

6 x 2,9W 2760 Lm 3000K Cri>80 220/240V  
6 x 2,9W 2580 Lm 2700K Cri>80 220/240V **LED**

### MIKADO LA 6\_L DIM PD

6 x 2,9W 2760 Lm 3000K Cri>80 220/240V  
6 x 2,9W 2580 Lm 2700K Cri>80 220/240V  
con driver dimmerabile push/with push dimmable driver 220/240V **LED**

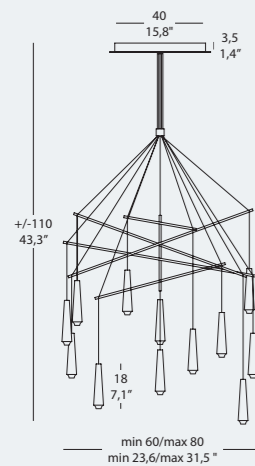

### MIKADO LA 12 GLASS\_S

12 x 2,9W 5520 Lm 3000K Cri>80 220/240V  
12 x 2,9W 5160 Lm 2700K Cri>80 220/240V **LED**

### MIKADO LA 12 GLASS\_S DIM PD

12 x 2,9W 5520 Lm 3000K Cri>80 220/240V  
12 x 2,9W 5160 Lm 2700K Cri>80 220/240V  
con driver dimmerabile push/with push dimmable driver 220/240V **LED**

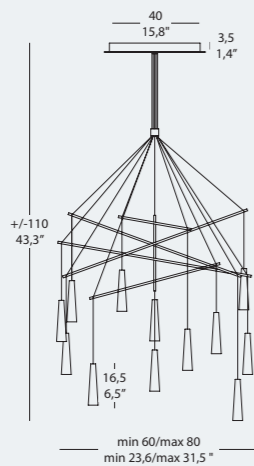

### MIKADO LA 12\_S

12 x 2,9W 5520 Lm 3000K Cri>80 220/240V  
12 x 2,9W 5160 Lm 2700K Cri>80 220/240V **LED**

### MIKADO LA 12\_S DIM PD

12 x 2,9W 5520 Lm 3000K Cri>80 220/240V  
12 x 2,9W 5160 Lm 2700K Cri>80 220/240V  
con driver dimmerabile push/with push dimmable driver 220/240V **LED**

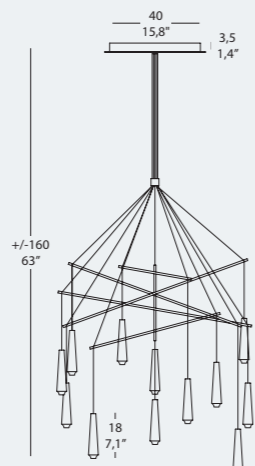

### MIKADO LA 12 GLASS\_L

12 x 2,9W 5520 Lm 3000K Cri>80 220/240V  
12 x 2,9W 5160 Lm 2700K Cri>80 220/240V **LED**

### MIKADO LA 12 GLASS\_L DIM PD

12 x 2,9W 5520 Lm 3000K Cri>80 220/240V  
12 x 2,9W 5160 Lm 2700K Cri>80 220/240V  
con driver dimmerabile push/with push dimmable driver 220/240V **LED**

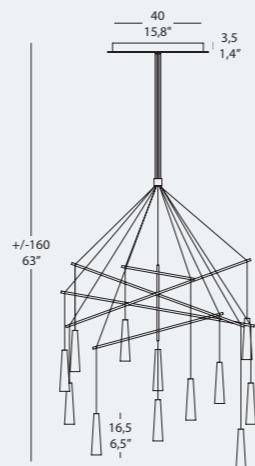

### MIKADO LA 12\_L

12 x 2,9W 5520 Lm 3000K Cri>80 220/240V  
12 x 2,9W 5160 Lm 2700K Cri>80 220/240V **LED**

### MIKADO LA 12\_L DIM PD

12 x 2,9W 5520 Lm 3000K Cri>80 220/240V  
12 x 2,9W 5160 Lm 2700K Cri>80 220/240V  
con driver dimmerabile push/with push dimmable driver 220/240V **LED**

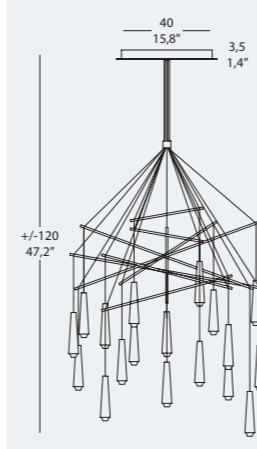

### MIKADO LA 18 GLASS\_S

18 x 2,9W 8280 Lm 3000K Cri>80 220/240V  
18 x 2,9W 7740 Lm 2700K Cri>80 220/240V **LED**

### MIKADO LA 18 GLASS\_S DIM PD

18 x 2,9W 8280 Lm 3000K Cri>80 220/240V  
18 x 2,9W 7740 Lm 2700K Cri>80 220/240V  
con driver dimmerabile push/with push dimmable driver 220/240V **LED**

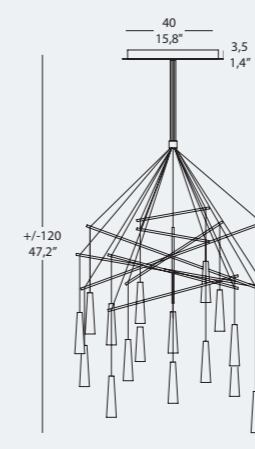

### MIKADO LA 18\_S

18 x 2,9W 8280 Lm 3000K Cri>80 220/240V  
18 x 2,9W 7740 Lm 2700K Cri>80 220/240V **LED**

### MIKADO LA 18\_S DIM PD

18 x 2,9W 8280 Lm 3000K Cri>80 220/240V  
18 x 2,9W 7740 Lm 2700K Cri>80 220/240V  
con driver dimmerabile push/with push dimmable driver 220/240V **LED**

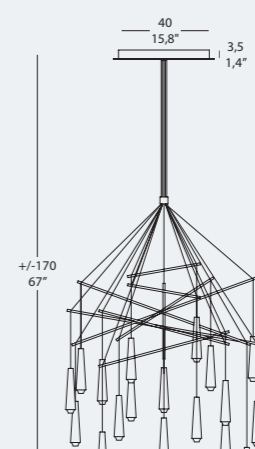

### MIKADO LA 18 GLASS\_L

18 x 2,9W 8280 Lm 3000K Cri>80 220/240V  
18 x 2,9W 7740 Lm 2700K Cri>80 220/240V **LED**

### MIKADO LA 18 GLASS\_L DIM PD

18 x 2,9W 8280 Lm 3000K Cri>80 220/240V  
18 x 2,9W 7740 Lm 2700K Cri>80 220/240V  
con driver dimmerabile push/with push dimmable driver 220/240V **LED**

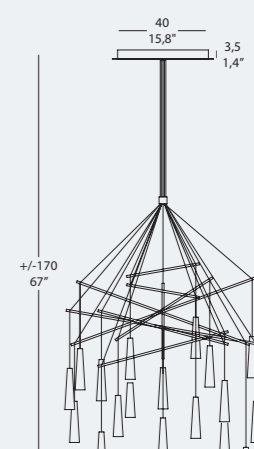

### MIKADO LA 18\_L

18 x 2,9W 8280 Lm 3000K Cri>80 220/240V  
18 x 2,9W 7740 Lm 2700K Cri>80 220/240V **LED**

### MIKADO LA 18\_L DIM PD

18 x 2,9W 8280 Lm 3000K Cri>80 220/240V  
18 x 2,9W 7740 Lm 2700K Cri>80 220/240V  
con driver dimmerabile push/with push dimmable driver 220/240V **LED**



SU RICHIESTA È POSSIBILE AVERE ANCHE DRIVER DIMMERABILE 1/10V  
1/10V DIMMABLE DRIVER CAN BE SUPPLIED BY REQUEST

### BARRA/BAR 50 NERO/BLACK

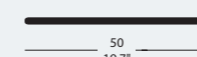

### BARRA/BAR 75 NERO/BLACK



### DIFFUSORE/DIFFUSER

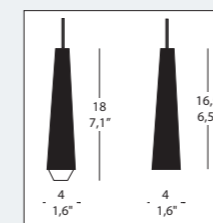



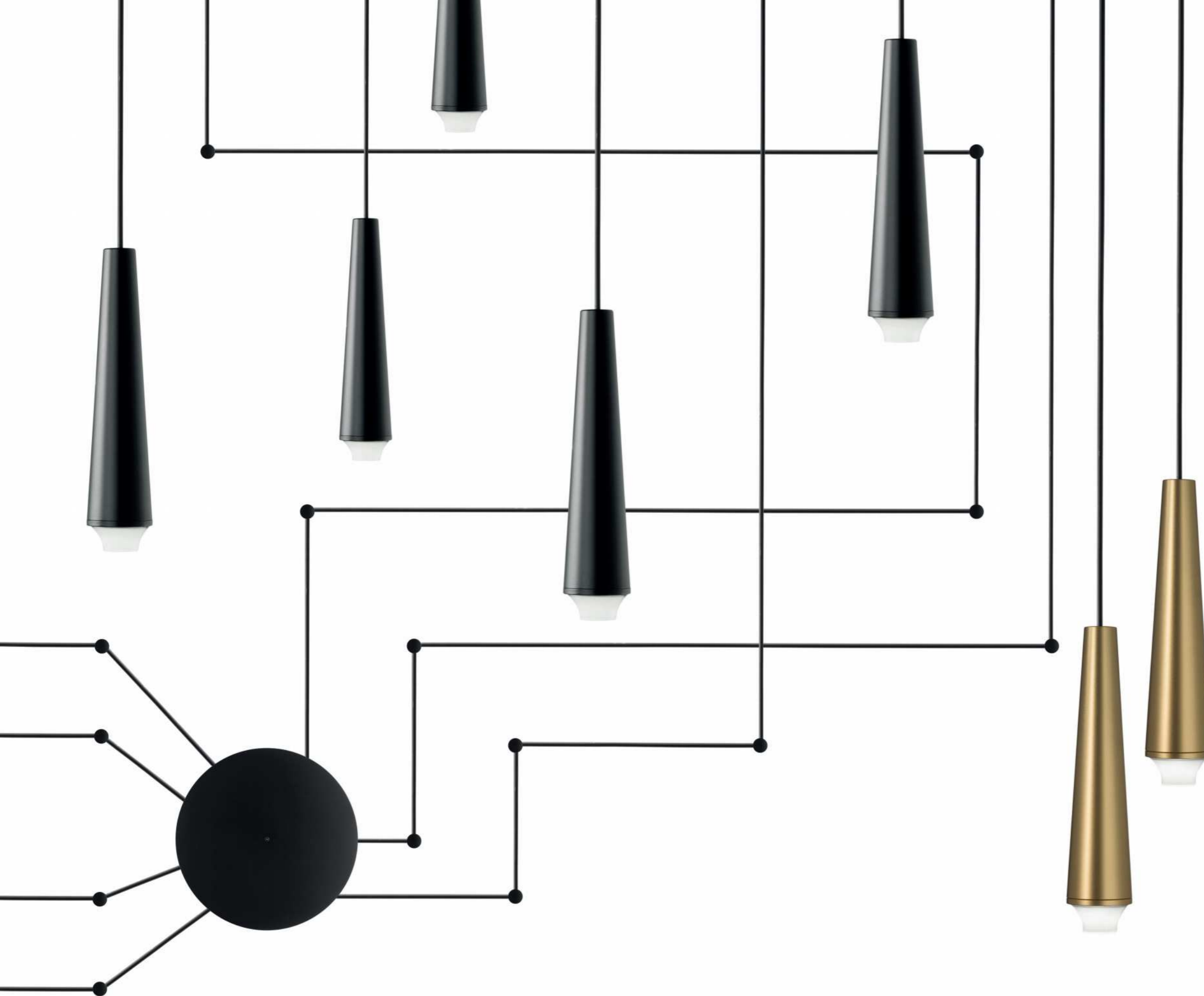

# MIKADO ZERO

design\_Filippo Mambretti

Geometrie di luce.

Lighting geometrics.



Mikado Zero\_ esempio di personalizzazione a 4 luci/4 light customized composition example



Mikado Zero\_ esempio di personalizzazione a 7 luci/7 light customized composition example



# MIKADO ZERO

## \_technical data

illuminazione personalizzabile. Dopo la premiata versione della collezione Mikado, nasce la nuova versione "Mikado Zero". Un nuovo modo di pensare gli spazi e di approcciarsi al progetto, grazie alle infinite configurazioni che possono avere il punto luce sia a soffitto che a parete, creando forme lineari o geometriche di grande effetto scenografico. Disponibile con una serie di rosoni che permettono soluzioni da 2 a 10 elementi in alluminio completi di LED a 2700K e 3000K, con o senza vetro diffusore satinato. L'intera collezione viene fornita in versione dimmerabile.

Customizable lighting. After the award-winning version of the Mikado collection, we have created the new "Mikado Zero" version. A new way of conceiving space and a new design approach thanks to the infinite configurations of ceiling and wall lighting sources that create linear or geometric patterns offering a great scenic effect. Available with a range of ceiling plates that enable solutions featuring 2 to 10 aluminum elements with 2700K and 3000K LEDs, with or without frosted glass. The entire collection is supplied in a dimmable version.

Individuell gestaltbare Beleuchtung. Infolge der ausgezeichneten Version der Kollektion Mikado entsteht die neue Version "Mikado Light". Eine neue Weise, die Räume zu entwerfen und sich dem Projekt zu nähern, dank der unendlichen Konfigurationen, die einen Lichtpunkt an der Decke wie an der Wand haben können und so lineare oder geometrische Formen mit einem effektvollen szenographischen Effekt bilden. Mit verschiedenen Rosetten, die Lösungen mit 2 bis 10 Elementen aus Aluminium ermöglichen, einschließlich LED mit 2700K und 3000K, mit oder ohne satiniertem Glaslichtschirm. Die ganze Kollektion wird in der dimmerbaren Ausführung geliefert.

Éclairage personnalisable. Après la version mainte fois primée de la collection Mikado, voici la nouvelle version "Mikado Zero". Une nouvelle manière de concevoir les espaces et d'aborder le projet, grâce aux infinies configurations possibles de l'éclairage au plafond ou mural, en créant des formes linéaires ou géométriques d'un grand effet scénographique. Elle est dotée d'une série de rosaces pour des solutions de 2 à 10 éléments en aluminium, avec des LED de 2700K et 3000K, avec ou sans diffuseur en verre satiné. L'ensemble de la collection est fourni dans la version dimmable.

Iluminación personalizable. Después de la versión premiada de la colección Mikado, hemos creado la nueva versión "Mikado Zero". Una nueva forma de concebir el espacio y un nuevo enfoque de diseño gracias a las configuraciones infinitas de fuentes de luz de techo y pared que crean patrones lineales o geométricos que ofrecen un gran efecto escénico. Disponible con una serie de florones que permiten una solución de 2 a 10 elementos en todos los componentes de LED a 2700K y 3000K, con o sin vidrio esmerilado. Todas las lámparas de la colección tienen el dimmer incorporado.

Настраиваемое освещение. После высоко оцененной версии коллекции Mikado, создана новая версия "Mikado Zero". Новый способ осмысливания пространства и ознакомления с проектом благодаря многочисленным возможностям конфигураций, которые позволяют иметь источники освещения как на потолке, так и на стене, создавая линейные или геометрические формы впечатляющего сценарического эффекта. Предоставляется с комплекции серий круглых розеток, которые позволяют осуществить решения с элементами из алюминия от 2 до 10 штук, укомплектованные ЛЕД 2700К и 3000К, с или без матированного рассеивающего стекла. Полная коллекция предоставляется в версии регулируемой яркости.

**Struttura:** metallo nero opaco o oro.

**Frame:** matt black metal or gold.

**Struktur:** Metall, mattschwarz oder Gold.

**Structure:** métal noir mat ou or. **Diffuseur:** verre satiné.

**Estructura:** metal negro opaco o oro.

**Структура:** металл, выполняется в цвете: черный матовый или золото. **Рассеиватель:** Сатинированное стекло.

**Diffusore:** vetro satinato.

**Diffuser:** satin glass.

**Diffusor:** Satiniertes Glas.



**07:** Nero opaco/  
Matt Black



**22:** Oro opaco/  
Matt Gold

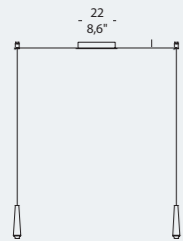

### MIKADO ZERO SO 2 GLASS DIM PD

2 x 2,9W 920 Lm 3000K Cri>80 220/240V  
2 x 2,9W 860 Lm 2700K Cri>80 220/240V  
con driver dimmerabile push  
with push dimmable driver 220/240V

CE IP 20 EAC

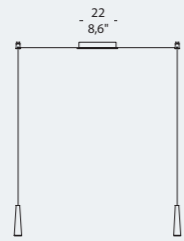

### MIKADO ZERO SO 2 DIM PD

2 x 2,9W 920 Lm 3000K Cri>80 220/240V  
2 x 2,9W 860 Lm 2700K Cri>80 220/240V  
con driver dimmerabile push  
with push dimmable driver 220/240V

CE IP 20 EAC

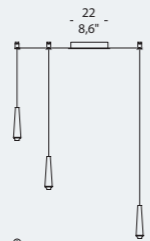

### MIKADO ZERO SO 3 GLASS DIM PD

3 x 2,9W 1380 Lm 3000K Cri>80 220/240V  
3 x 2,9W 1290 Lm 2700K Cri>80 220/240V  
con driver dimmerabile push  
with push dimmable driver 220/240V

CE IP 20 EAC

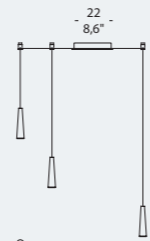

### MIKADO ZERO SO 3 DIM PD

3 x 2,9W 1380 Lm 3000K Cri>80 220/240V  
3 x 2,9W 1290 Lm 2700K Cri>80 220/240V  
con driver dimmerabile push  
with push dimmable driver 220/240V

CE IP 20 EAC

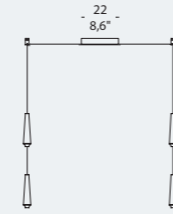

### MIKADO ZERO SO 4 GLASS DIM PD

4 x 2,9W 1840 Lm 3000K Cri>80 220/240V  
4 x 2,9W 1720 Lm 2700K Cri>80 220/240V  
con driver dimmerabile push  
with push dimmable driver 220/240V

CE IP 20 EAC

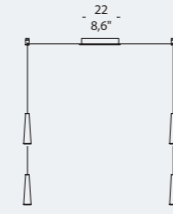

### MIKADO ZERO SO 4 DIM PD

4 x 2,9W 1840 Lm 3000K Cri>80 220/240V  
4 x 2,9W 1720 Lm 2700K Cri>80 220/240V  
con driver dimmerabile push  
with push dimmable driver 220/240V

CE IP 20 EAC

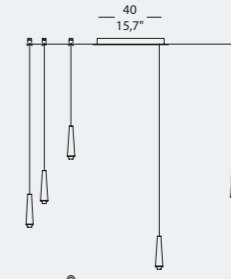

### MIKADO ZERO SO 5 GLASS DIM PD

5 x 2,9W 2300 Lm 3000K Cri>80 220/240V  
5 x 2,9W 2150 Lm 2700K Cri>80 220/240V  
con driver dimmerabile push  
with push dimmable driver 220/240V

CE IP 20 EAC

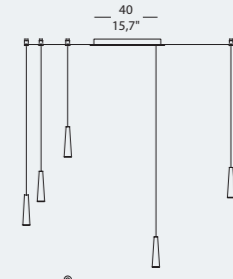

### MIKADO ZERO SO 5 DIM PD

5 x 2,9W 2300 Lm 3000K Cri>80 220/240V  
5 x 2,9W 2150 Lm 2700K Cri>80 220/240V  
con driver dimmerabile push  
with push dimmable driver 220/240V

CE IP 20 EAC

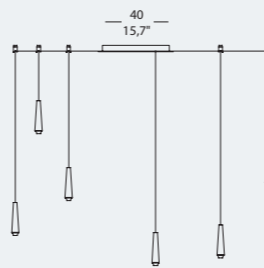

### MIKADO ZERO SO 6 GLASS DIM PD

6 x 2,9W 2760 Lm 3000K Cri>80 220/240V  
6 x 2,9W 2580 Lm 2700K Cri>80 220/240V  
con driver dimmerabile push  
with push dimmable driver 220/240V

CE IP 20 EAC

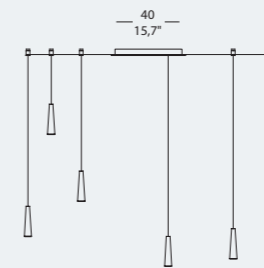

### MIKADO ZERO SO 6 DIM PD

6 x 2,9W 2760 Lm 3000K Cri>80 220/240V  
6 x 2,9W 2580 Lm 2700K Cri>80 220/240V  
con driver dimmerabile push  
with push dimmable driver 220/240V

CE IP 20 EAC

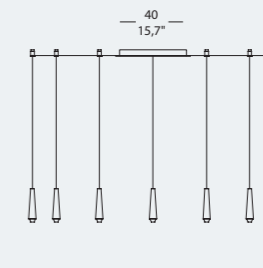

### MIKADO ZERO SO 7 GLASS DIM PD

7 x 2,9W 3220 Lm 3000K Cri>80 220/240V  
7 x 2,9W 3010 Lm 2700K Cri>80 220/240V  
con driver dimmerabile push  
with push dimmable driver 220/240V

CE IP 20 EAC

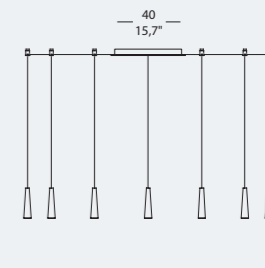

### MIKADO ZERO SO 7 DIM PD

7 x 2,9W 3220 Lm 3000K Cri>80 220/240V  
7 x 2,9W 3010 Lm 2700K Cri>80 220/240V  
con driver dimmerabile push  
with push dimmable driver 220/240V

CE IP 20 EAC

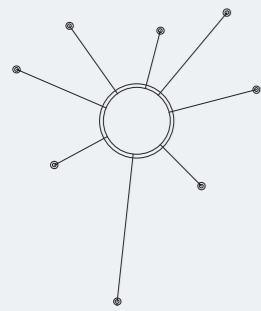
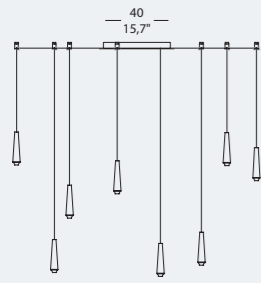

**MIKADO ZERO S0 8 GLASS DIM PD**  
 8 x 2,9W 3680 Lm 3000K Cri>80 220/240V  
 8 x 2,9W 3440 Lm 2700K Cri>80 220/240V  
 con driver dimmerabile push  
 with push dimmable driver 220/240V **LED**  
**CE** **F** **IP 20** **ERC**

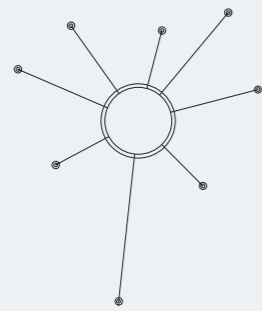
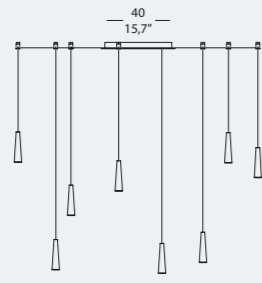

**MIKADO ZERO S0 8 DIM PD**  
 8 x 2,9W 3680 Lm 3000K Cri>80 220/240V  
 8 x 2,9W 3440 Lm 2700K Cri>80 220/240V  
 con driver dimmerabile push  
 with push dimmable driver 220/240V **LED**  
**CE** **F** **IP 20** **ERC**

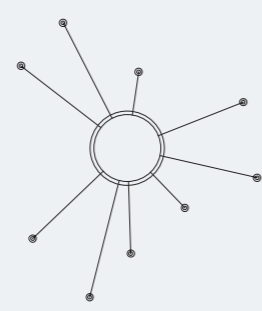
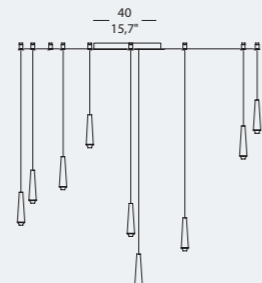

**MIKADO ZERO S0 9 GLASS DIM PD**  
 9 x 2,9W 4140 Lm 3000K Cri>80 220/240V  
 9 x 2,9W 3870 Lm 2700K Cri>80 220/240V  
 con driver dimmerabile push  
 with push dimmable driver 220/240V **LED**  
**CE** **F** **IP 20** **ERC**

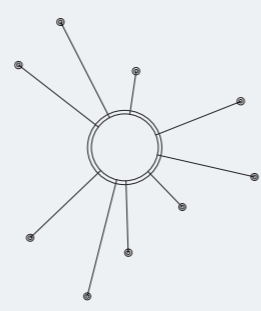
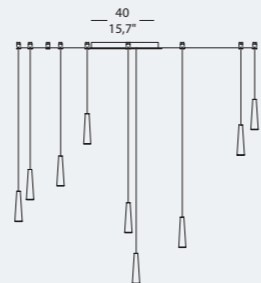

**MIKADO ZERO S0 9 DIM PD**  
 9 x 2,9W 4140 Lm 3000K Cri>80 220/240V  
 9 x 2,9W 3870 Lm 2700K Cri>80 220/240V  
 con driver dimmerabile push  
 with push dimmable driver 220/240V **LED**  
**CE** **F** **IP 20** **ERC**

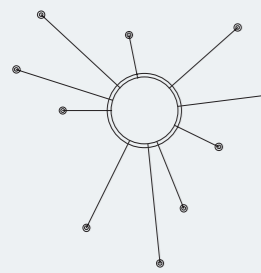
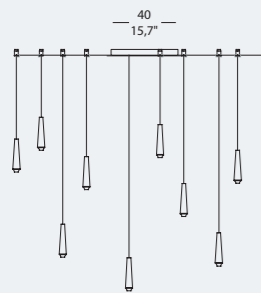

**MIKADO ZERO S0 10 GLASS DIM PD**  
 10 x 2,9W 4600 Lm 3000K Cri>80 220/240V  
 10 x 2,9W 4300 Lm 2700K Cri>80 220/240V  
 con driver dimmerabile push  
 with push dimmable driver 220/240V **LED**  
**CE** **F** **IP 20** **ERC**

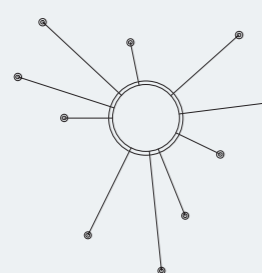
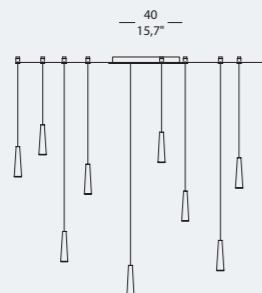

**MIKADO ZERO S0 10 DIM PD**  
 10 x 2,9W 4600 Lm 3000K Cri>80 220/240V  
 10 x 2,9W 4300 Lm 2700K Cri>80 220/240V  
 con driver dimmerabile push  
 with push dimmable driver 220/240V **LED**  
**CE** **F** **IP 20** **ERC**

**DIFFUSORE/DIFFUSER**

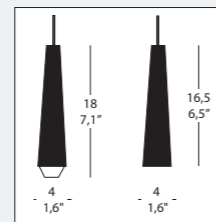

**SU RICHIESTA È POSSIBILE AVERE ANCHE DRIVER DIMMERABILE 1/10V.  
 1/10V DIMMABLE DRIVER CAN BE SUPPLIED BY REQUEST.**

**ESEMPI DI PERSONALIZZAZIONE/CUSTOMIZED COMPOSITION EXAMPLE**

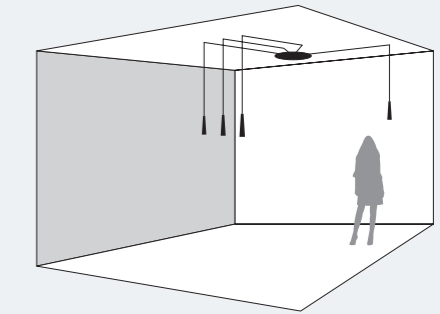
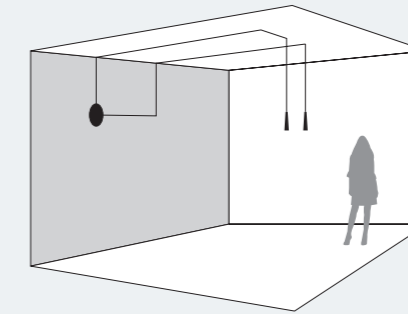
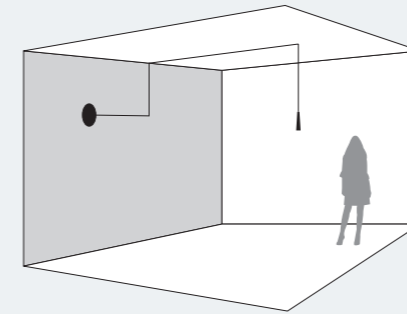

**COMPOSIZIONI STANDARD/STANDARD COMPOSITIONS**

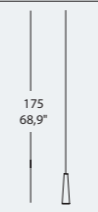
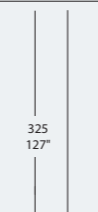
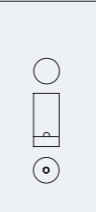
	 Cavo corto Short cable	 Cavo lungo Long cable	 Decentramento Off centre position
	Quantità Quantity	Quantità Quantity	Quantità Quantity
<b>S0 2</b>	2	0	2
<b>S0 3</b>	2	1	3
<b>S0 4</b>	2	2	4
<b>S0 5</b>	3	2	5
<b>S0 6</b>	4	2	6
<b>S0 7</b>	4	3	7
<b>S0 8</b>	5	3	8
<b>S0 9</b>	6	3	9
<b>S0 10</b>	6	4	10





# PANK

design\_Tiziano Maffione

Un taglio decisamente  
particolare.

Definitely a peculiar cut.





Pank\_SO 23



Pank\_SO 30/50





Pank\_SO 30



Pank\_SO 18

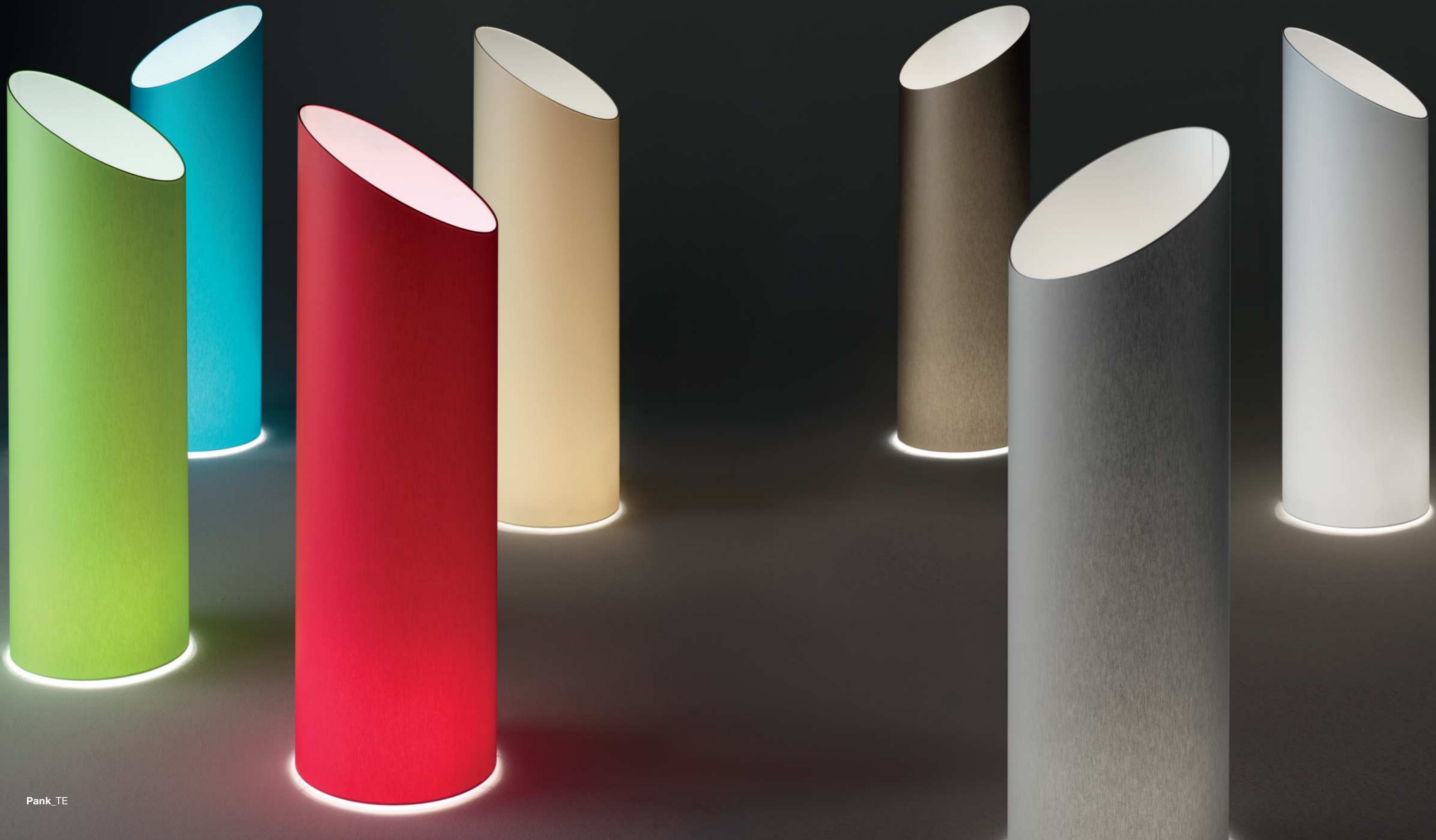





Pank\_TE

Pank\_PL 18 / 23 / 30 / 50



Pank\_TA





Pank\_PL 30



Pank\_PL 90



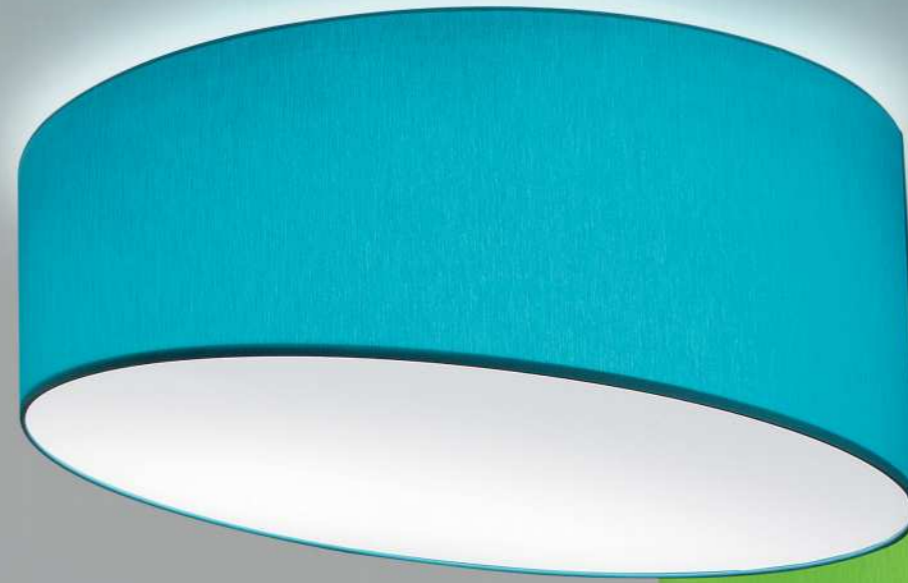



Pank\_PL 120

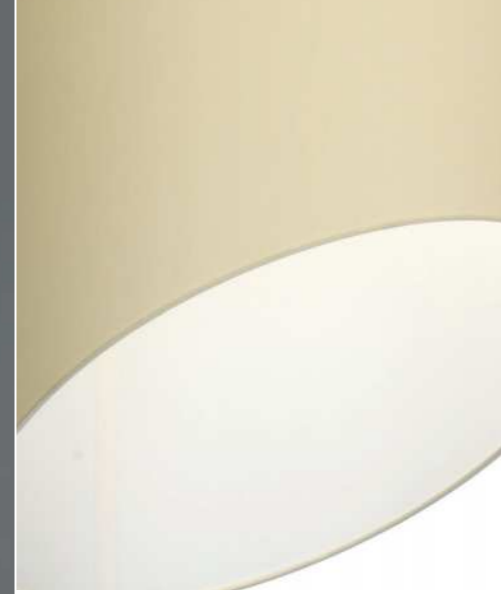

**AV:** Avorio/Ivory



**AZ:** Azzurro/Sky-blue



**BI:** Bianco/White



**GR:** Grigio/Grey



**RE:** Rosso/Red



**TO:** Tortora/Dove-Grey



**VE:** Verde/Green



**NE:** Nero/Black

I COLORI ORIGINALI DEI PARALUMI, POSSONO DIFFERIRE DALLA RIPRODUZIONE SU CARTA, SIA DA ACCESI CHE DA SPENTI.

THE EFFECTIVE COLOURS OF THE LAMPSHADES MAY DIFFER SLIGHTLY FROM THE COLOURS REPRODUCED ON PAPER, WITH THE LIGHT EITHER ON OR OFF.

ES IST MÖGLICH, DASS SICH DIE ORIGINALFARBEN DER LAMPENSCHIRME VON DER ABBILDUNG AUF PAPIER UNTERSCHIEDEN, SOWOHL IM LEUCHTZUSTAND ALS AUCH IM ERLOSCHENEN ZUSTAND.

LES COULEURS ORIGINALES DES ABAT-JOUR (LAMPE ETEINTE OU ALLUMÉE) PEUVENT DIFFERER DE LA REPRODUCTION SUR PAPIER.

LOS COLORES ORIGINALES DE LAS PANTALLAS PUEDEN DIFERIR DE LA REPRODUCCIÓN EN PAPEL, TANTO AL ESTAR ENCENDIDAS COMO APAGADAS.

ОРИГИНАЛЬНЫЕ ЦВЕТА АБАЖУРОВ МОГУТ ОТЛИЧАТЬСЯ ОТ ВОСПРОИЗВЕДЕННЫХ НА БУМАГЕ, КАК ВО ВКЛЮЧЕННОМ, ТАК И В ОТКЛЮЧЕННОМ СОСТОЯНИИ.



# PANK

## \_technical data

Un semplice taglio obliquo su una struttura cilindrica.

Questa è Pank. Un'idea essenziale, ma capace di riassumere e di condensare tutta la creatività e l'ingegno del design dell'illuminazione. Pank è dinamicità. Grazie alla sua particolare linea, la forma della lampada muta a seconda del punto di vista, trasmettendo movimento a tutto l'arredamento. Pank è estro.

Le molteplici dimensioni e combinazioni cromatiche, con i loro contrasti tra interno ed esterno, sono un invito a giocare con i colori e con l'arredamento. Permettono inoltre alla lampada di adattarsi facilmente sia allo stile moderno e giovane che a quello più elegante e classico. Pank è versatilità. La vasta gamma di versioni permette alla collezione di dimostrarsi la soluzione perfetta per diverse esigenze di spazio e arredamento, oltre che di illuminazione. Il fascio luminoso può essere infatti indirizzato in base alla necessità di luce o d'atmosfera. Pank è eccellenza.

La scelta dei materiali, tra cui il tessuto a tramatura evidente, così come la cura di fabbricazione, testimoniano l'attenzione alla qualità e all'esperienza sensoriale, che rappresentano il segno distintivo del brand Morosini.

Une simple coupe oblique sur une structure cylindrique.

C'est la lampe Pank. Une idée essentielle mais capable de résumer et de condenser toute la créativité et le génie du design de l'éclairage. Pank est synonyme de dynamisme. Grâce à sa ligne particulière, la forme de la lampe se transforme en fonction du point de vue, transmettant du mouvement à toute la décoration. Pank est synonyme d'inspiration. De nombreuses dimensions et combinaisons chromatiques, avec leurs contrastes entre l'intérieur et l'extérieur, sont une invitation à jouer avec les couleurs et avec la décoration. Elle permet également à la lampe de s'adapter facilement à un style moderne et jeune et à un style plus élégant et classique. Pank est synonyme de polyvalence.

Grâce à la vaste gamme de versions, la collection est la solution parfaite pour différentes exigences d'espace et de décoration, au-delà de l'éclairage. Le faisceau lumineux peut en effet être orienté en fonction de la lumière ou de l'atmosphère souhaitée.

Pank est synonyme d'excellence. Le choix des matériaux, comme le tissu à tramage évident, tout comme le soin de la fabrication, témoignent de l'attention portée à la qualité et à l'expérience sensorielle, qui représentent le signe distinctif de la marque Morosini.

A simple oblique cut on a cylindrical structure.

This is Pank. An essential idea, able to summarize and concentrate all the creativity and brilliance of lighting design. Pank is dynamism. Thanks to its particular line, the shape of the lamp changes depending on the point of view, spreading movement to all the furniture. Pank is inspiration.

The multiple sizes and color combinations, with their contrasts between inside and outside, are an invite to play with the colors and the furniture. It also allows the lamp to be easily adapted to both the young-modern and the more elegant and classic style.

Pank is versatility. The wide range of versions allows the collection to be the perfect solution for different needs of space and furnishings, as well as for lighting needs. As a matter of fact, the beam of light can be moved according to the light and atmosphere you need.

Pank is excellence. The choice of materials, such as the evident weave of the fabric, as well as the production care, shows the attention to the quality and to the sensory experience, which are the hallmark of Morosini brand.

Un simple corte oblicuo en una estructura cilíndrica.

Esto es Pank. Una idea esencial pero en condiciones de resumir y condensar toda la creatividad y el ingenio del design de la iluminación. Pank es dinamismo. Gracias a su particular línea, la forma de la lámpara cambia según el punto de vista, transmitiendo movimiento a toda la decoración. Pank es estro. Las múltiples dimensiones y combinaciones cromáticas, con sus contrastes entre interior y exterior, son una invitación a jugar con los colores y con la decoración. Permiten además a la lámpara adaptarse fácilmente tanto al estilo moderno y juvenil como la más elegante y clásica. Pank es versatilidad. La vasta gama de versiones permite a la colección demostrarse como la solución perfecta para varias exigencias de espacio y decoración, además que de iluminación. En efecto, el haz luminoso puede dirigirse sobre la base de las necesidades de luz o de atmósfera. Pank es excelencia.

La selección de los materiales entre los cuales está el tejido de trama evidente, así como el cuidado en la fabricación, testimonian la atención a la calidad y a la experiencia sensorial, que representan el signo distintivo del brand Morosini.

Ein einfacher, schräger Schnitt auf einer zylindrischen Struktur. Das ist Pank. Eine essentielle Idee, die die ganze Kreativität und Intelligenz des Beleuchtungsdesigns zusammenfasst und kondensiert. Pank ist Dynamik. Dank ihrer besonderen Form ändert sich die Lampe je nach Betrachtungspunkt und verleiht der ganzen Einrichtung Bewegung. Pank ist Schwung. Die vielfältigen Dimensionen und Farbkombinationen mit ihren Kontrasten innen und außen sind eine Einladung, um mit den Farben und der Einrichtung zu spielen. Sie ermöglichen der Lampe außerdem, sich leicht dem modernen und jungen, aber auch dem eleganteren und klassischen Stil anzupassen. Pank ist Vielseitigkeit. Das große Angebot an Ausführungen ermöglicht der Kollektion, sich als perfekte Lösung für verschiedene Raum-, Einrichtungs- und auch Beleuchtungsanforderungen anzubieten. Das Lichtbündel kann je nach Lichtbedarf oder gewünschter Atmosphäre ausgerichtet werden. Pank ist Spitzenqualität. Die Wahl der Materialien, darunter der Stoff mit dem klaren Muster, wie auch die akurate Herstellung zeugen von der Beachtung der Qualität und der sinnlichen Erfahrung, die das unterscheidende Merkmal des Markenzeichens Morosini sind.

Простое наклонное сечение цилиндрической структуры. Это Pank. Эссенциальная идея, способная сконцентрировать весь творческий потенциал и возможности светового дизайна. Pank – это динамичность. Благодаря своей особой линии, форма лампы, меняющиеся в зависимости от угла зрения, придает движение всему интерьеру. Pank – это вдохновение. Многообразные размеры и сочетания цветов с контрастом между внутренней и внешней сторонами – приглашение играть с цветом и соформлением интерьеров. Позволяют светильникам адаптироваться к любому интерьерному стилю, от самого молодежного и современного до истинно элегантного и классического. Pank – это многогранность. Широкая гамма версий позволяет коллекции превосходно удовлетворить как требования по освещению, так и требований к пространству и интерьеру. Световой лучок может быть направлен в зависимости от потребности в свете или атмосферы. Pank – это совершенство.

Выбор материалов, среди которых ткань среди которых ткань с характерным переплетением, наряду с тщательным исполнением при изготовлении, свидетельствуют о внимании к качеству и о способности к восприятию, являющиеся отличительной чертой бренда Morosini.

Простое наклонное сечение цилиндрической структуры.

Это Pank. Эссенциальная идея, способная сконцентрировать весь творческий потенциал и возможности светового дизайна.

Pank – это динамичность. Благодаря своей особой линии, форма лампы, меняющиеся в зависимости от угла зрения, придает движение всему интерьеру. Pank – это вдохновение. Многообразные размеры и сочетания цветов с контрастом между внутренней и внешней сторонами – приглашение играть с цветом и соформлением интерьеров. Позволяют светильникам адаптироваться к любому интерьерному стилю, от самого молодежного и современного до истинно элегантного и классического. Pank – это многогранность. Широкая гамма версий позволяет коллекции превосходно удовлетворить как требования по освещению, так и требований к пространству и интерьеру. Световой лучок может быть направлен в зависимости от потребности в свете или атмосферы. Pank – это совершенство.

Выбор материалов, среди которых ткань среди которых ткань с характерным переплетением, наряду с тщательным исполнением при изготовлении, свидетельствуют о внимании к качеству и о способности к восприятию, являющиеся отличительной чертой бренда Morosini.

**Struttura:** metallo bianco opaco.

**Frame:** white matt metal.

**Diffusore:** paralumi in tessuto "chINETTE" nella vasta gamma di colori indicata nella scheda tecnica. Ad esclusione del colore Tortora, test filo incandescente 850°.

**Diffuser:** "chINETTE" fabric lampshades in the color range as specified in the data sheet. Glow wire test at 850°, except for dove grey color.

**Struktur:** Metall mattweiß.

**Diffusor:** Lampenschirme aus "Chinette"-Stoff in dem Farbangebot des technischen Datenblatts. Glühdrahtprüfung bei 850°C, außer taubengrau.

**Structure:** métal blanc mat.

**Diffuseur:** abat-jour en tissu "chINETTE" dans la vaste gamme de couleurs indiquée sur la fiche technique. À l'exception de la couleur gris tourterelle, essai au fil incandescent 850°.

**Estructura:** metal blanco opaco.

**Difusor:** pantallas en tejido "chINETTE" en la vasta gama de colores indicada en la ficha técnica. Prueba del hilo incandescente 850° excepto el color Tórtola.

**Структура:** металл, окрашенный в белый матовый цвет.

**Рассеиватель:** абажуры из ткани "chINETTE" представлены в широкой цветовой гамме, указанной в спецификации. Испытание раскаленной проволокой при 850°С (за исключением бледно-коричневого цвета с сероватым оттенком).

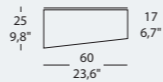

### PANK PL 60 E27

3 x MAX 10W E27 LED

### PANK PL 60 LED - PL 60 LED DIM \*

23,9W 4280 Lm 3000K Cri> 80 220/240V

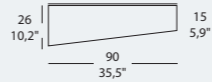

### PANK PL 90 E27

6 x MAX 10W E27 LED

### PANK PL 90 LED - PL 90 LED DIM \*

32,7W 6120 Lm 3000K Cri>80 220/240V

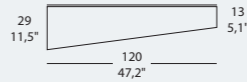

### PANK PL 120 E27

6 x MAX 10W E27 LED

### PANK PL 120 LED - PL 120 LED DIM \*

32,7W 6120 Lm 3000K Cri>80 220/240V



**DIM:** Dimmerabile/Dimmable/Dimmbar Regulable/Диммирование

**\* Con driver dimmerabile push With push dimmable driver**

Su richiesta è possibile avere anche driver dimmerabile DALI DALI dimmable driver can be supplied by request



### PANK PL 18

1 x MAX 13W E27 LED

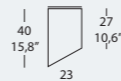

### PANK PL 23

1 x MAX 13W E27 LED



### PANK PL 30

1 x MAX 17,5W E27 LED



### PANK PL 50

4 x MAX 10W E27 LED

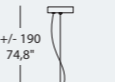

### PANK S0 18

1 x MAX 13W E27 LED



### PANK S0 23

1 x MAX 13W E27 LED

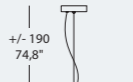

### PANK S0 30

1 x MAX 17,5W E27 LED

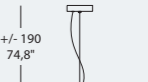

### PANK S0 50

4 x MAX 10W E27 LED



### PANK TE

3 x Max 13W E27 LED DIM



### PANK TA

1 x MAX 13W E27 LED





# FOG

design\_Andrea Lazzari  
Massimo Tonetto

Veste di velo,  
anima di vetro.

An ethereal shade  
and a softly glowing light.





Fog\_TE A



Fog\_SO 70





Fog\_SO 35



Fog\_SO 50







Fog\_PA 30



Fog\_TE





Fog\_PL 50



Fog\_CO

Con Fog, Morosini ha rivoluzionato il concetto di lampade a paralume. L'inserimento all'interno dei diffusori in stoffa Pongé di un elemento in vetro soffiato che traspare come immerso in una nebbia di luce è l'elemento caratterizzante che ha decretato il successo di questa collezione. Una scelta che non offusca, anzi risalta la raffinatezza estetica della collezione Fog e la qualità dei materiali selezionati, sprigionando intorno alla lampada un'atmosfera delicata ed elegante, che arreda con semplicità e gusto soprattutto i grandi ambienti. Le lampade Fog sono infatti disponibili in molteplici versioni e dimensioni, anche su misura. Il tessuto utilizzato per i paralumi ha passato la prova del filo incandescente a 850°C, che lo rende adatto anche a installazioni in ambienti pubblici.

Creating Fog, Morosini has revolutionized the concept of lamps with lampshades. The element in blown glass inside the fabric pongé shades that appears as immersed in a light fog, is the key element that has guaranteed the success of this collection. A choice that does not obscure, indeed shows the aesthetic refinement of the collection Fog and the quality of the selected materials, creating around the lamp a delicate and elegant atmosphere, which furnishes with simplicity and taste especially large spaces. Fog lamps are available in fact in several models and sizes, also customized. The fabric used for the lampshades passed the glow wire test at 850°C, which makes it suitable for installation in public spaces.

Mit Fog hat Morosini das Konzept der Lampen mit Lampenschirm revolutioniert. Das Einführen in die Pongé-Stoffdiffusoren eines geblasenen Glaselements, das wie in einen Lichtnebel getaucht durchscheint, ist das charakterisierende Element, das den Erfolg dieser Kollektion ausgezeichnet hat. Eine Entscheidung, die die ästhetische Eleganz der Kollektion und die Qualität der gewählten Materialien nicht verschleiert, sondern hervorhebt und um die Lampe eine zarte und elegante Atmosphäre bildet, die mit Einfachheit und Geschmack vor allem große Umgebungen einrichtet. Die Lampen Fog sind vielmehr in zahlreichen Versionen und Abmessungen erhältlich, auch nach Kundenwünschen angepasst. Die Stoffe für die Lampenschirme haben die Glühdrahtprüfung bei 850°C bestanden, somit kann die Lampe auch für öffentliche Umgebungen verwendet werden.

Avec Fog, Morosini a révolutionné le concept de lampe à abat-jour. L'insertion à l'intérieur des diffuseurs en tissu d'un élément en verre soufflé qui transparaît comme s'il était immergé dans un brouillard de lumière est l'élément caractérisant qui a décréé le succès de cette collection. Un choix qui n'offusque pas, ou plutôt qui met en valeur le raffinement esthétique de la collection Fog et la qualité des matériaux sélectionnés, dégagant autour de la lampe une atmosphère délicate et élégante, qui décore avec simplicité et goût surtout les grands espaces. Les lampes Fog sont en effet fournies dans de nombreuses versions et dimensions, également sur mesure. Le tissu utilisé pour les abat-jour a subi avec succès l'essai du fil incandescent à 850° qui permet de l'utiliser dans les lieux publics.

Con Fog, Morosini ha revolucionado el concepto de lámparas de pantallas. La inclusión en el interior de los difusores de tela Pongé de un elemento de vidrio soplado que trasparece como inmerso en una niebla de luz es el elemento característico que ha hecho el éxito de esta colección. Una elección que no ofusca sino al contrario, pone de manifiesto el refinamiento estético de la colección Fog y la calidad de los materiales seleccionados, liberando alrededor de la lámpara una atmósfera delicada y elegante, que decora con sencillez y gusto sobre todo grandes ambientes. Las lámparas Fog están en efecto disponibles en múltiples versiones y dimensiones incluso a la medida. El tejido utilizado para las pantallas ha pasado la prueba del hilo incandescente a 850° que lo hace apto incluso para instalaciones en ambientes públicos.

Morosini с коллекцией Fog коренным образом изменяет само понятие лампы и абажура. Размещение внутри рассеивателя из ткани Pongé элемента из дутого стекла, просвечивающегося как-будто погруженный в светящийся туман – ключевое решение, принесшее успех этой коллекции. Выбор, который не только не затмевает, более того, подчеркивает эстетическую утонченность коллекции Fog и качество выбранных материалов, распространяя вокруг лампы элегантную и нежную атмосферу, способную с простотой и вкусом украсить прежде всего большие пространства. Светильники Fog доступны в различных версиях и размерах, также имеется возможность создавать модели по индивидуальным заказам. Ткань, используемая для абажура, прошла испытание раскаленной проволокой при температуре 850°C. Таким образом ее можно использовать для общественных помещений.

**Struttura:** metallo nichel satinato, disponibile nelle varianti bianco opaco e nero opaco per la sola versione da terra ad arco.

**Frame:** satin finish nickel metal, available also in matt white and matt black only for the arc floor version.

**Diffuser:** milkwhite frosted blown glass and Pongé fabric lampshades available in these colors: white, black and moka. Glow wire test at 850°.

**Struktur:** Metall nickelsatiniert, mattweiß und mattschwarz nur für die Boden-Bogenlampe erhältlich.

**Diffuser:** Satiniertes, milchweißes geblasenes Glas und Lampenschirme aus Pongé-Stoff in den Farben: Weiß, Schwarz und Mokka. Glühdrahtprüfung bei 850°C.

**Structure:** métal nickel satiné, fourni dans les variantes blanc mat et noir mat uniquement pour le lampadaire en arc.

**Diffuser:** verre soufflé blanc lait satiné et abat-jour en tissu Pongé dans les coloris blanc, noir et moka. Essai au fil incandescent 850°.

**Estructura:** metal níquel satinado, disponible en las variables blanco opaco y negro opaco solo para versión de pie a arco.

**Difusor:** vidrio soplado blanco leche satinado y pantallas de tela Pongé en los colores: blanco, negro y moka. Prueba del hilo incandescente 850°.

**Структура:** сатинированный никель. Для торшера, в виде арки, может быть выполнена также в матовом белом или матовом черном цветах. **Рассеиватель:** дутое матовое стекло молочного белого цвета; абажуры из ткани Pongé белого, черного и темно-коричневого цвета. Испытание раскаленной проволокой при 850°C.

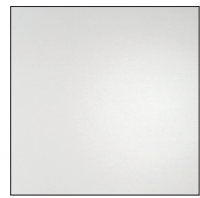

BI: Bianco/White



MK: Moka/Moka



NO: Nero/Black

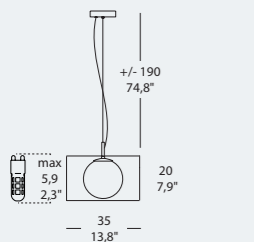

### FOG SO 35

1 x MAX 4,8W G9 LED

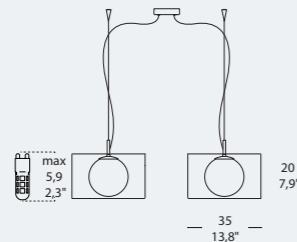

### FOG SO 35/2

2 x MAX 4,8W G9 LED

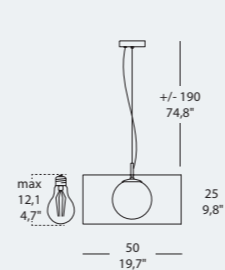

### FOG SO 50

1 x MAX 13W E27 LED

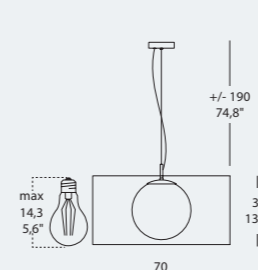

### FOG SO 70

1 x MAX 17,5W E27 LED

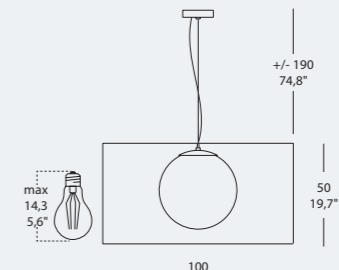

### FOG SO 100

1 x MAX 17,5W E27 LED

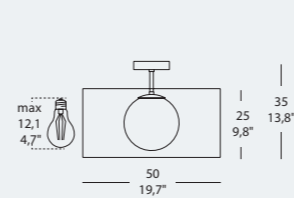

### FOG PL 50

1 x MAX 13W E27 LED

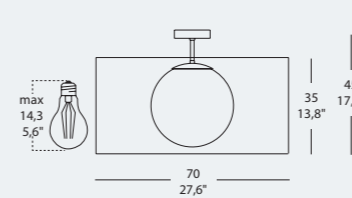

### FOG PL 70

1 x MAX 17,5W E27 LED

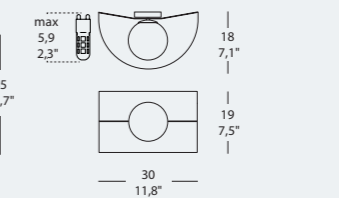

### FOG PA 30

1 x MAX 4,8W G9 LED

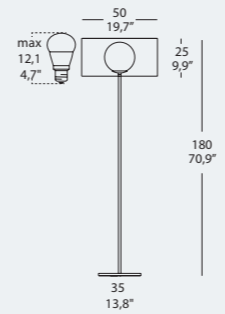

### FOG TE

1 x MAX 13W E27 LED DIM

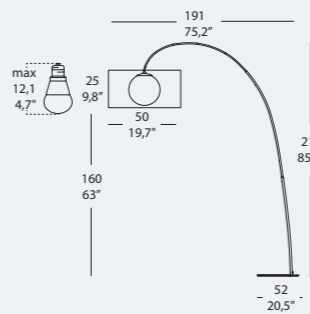

### FOG TE A

1 x MAX 13W E27 LED DIM

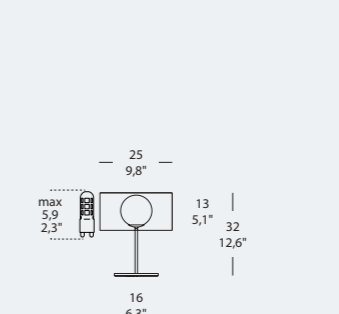

### FOG CO

1 x MAX 4,8W G9 LED







# FOG PLISSÉ

design\_Andrea Lazzari  
Massimo Tonetto

Semplice, discreta, elegante.

Essential, subtle, refined.





Fog Plissé\_TE A



Fog Plissé\_PL 50





Fog Plissé\_PA 30



Fog Plissé\_SO 70





Fog Plissé\_TE



Fog Plissé\_CO



# FOG PLISSÉ

## \_technical data

La collezione Fog Plissé unisce raffinata eleganza e funzionalità. Queste lampade creano una gradevole luce diffusa, grazie al loro paralume in tessuto plissettato e al diffusore interno di forma sferica in vetro soffiato.

Semplice e discreta ma allo stesso tempo elegante, Fog Plissé si adatta ai grandi spazi e a qualsiasi tipo di arredamento domestico e contract, grazie alla possibilità di creare modelli su misura.

La collection Fog Plissé mêle l'élégance raffinée et la fonctionnalité. Ces lampes créent une lumière diffuse agréable, grâce à leur abat-jour en tissu plissé et à un diffuseur interne de forme sphérique en verre soufflé.

Simple et discrète mais en même temps élégante, Fog Plissé s'adapte aux grands espaces et à tout type de décoration résidentielle et collective grâce à la possibilité de créer des modèles sur mesure.

"Fog plissé" collection joins refined elegance with functionality. These lamps create a beautiful diffused light, thanks to their Plisse fabric shade and to an internal blown glass globe diffuser. Simple, moderate but at the same time very elegant, "Fog Plissé" adapts itself to the great outdoors and to all kinds of home furnishings and contracts with the ability to create customized models.

La colección Fog Plissé combina elegancia y funcionalidad. Estas lámparas crean una luz difusa agradable, gracias a su pantalla de tela plisada y a un difusor de forma esférica en vidrio soplado. Simple y discreta pero al mismo tiempo elegante, Fog Plissé se adapta a grandes espacios y cualquier tipo de muebles domésticos y contract gracias a la posibilidad de crear modelos a la medida.

Die Kollektion Fog Plissé vereint eine außergewöhnliche Eleganz und Funktionalität. Diese Lampen bilden einen angenehmen diffusen Lichteffekt, dank des Lampenschirms aus plisziertem Stoff und eines internen kugelförmigen Diffusors aus geblasenem Glas. Einfach und diskret, aber auch gleichzeitig elegant. Fog Plissé passt sich großen Räumen, jeder häuslichen und Contract-Einrichtungsart an, dank der Möglichkeit maßgeschneiderte Modelle zu kreieren.

Коллекция Fog Plissé объединяет утонченную элегантность и функциональность.

Этот светильник создает прятный рассеянный свет, благодаря плиссированному абажуру и внутреннему рассеивателю из дутого стекла в форме шара.

Простая и скромная, но в тоже время элегантная, Fog Plissé, благодаря своей возможности создавать модели по индивидуальным размерам, прекрасно подходит для больших пространств, для любых интерьеров частных и общественных помещений.

**Struttura:** metallo nichel satinato, disponibile nelle varianti bianco opaco e nero opaco per la sola versione da terra ad arco.

**Diffusore:** vetro soffiato bianco latte satinato e paralumi in tessuto Pongé nei colori: avorio, bianco, nero e moka. Ignifugo classe 1.

**Frame:** satin finished nickel metal, available also in matt white and matt black only for the arc floor version.

**Diffuser:** milkwhite frosted blown glass and Pongé fabric lampshades available in these colors: ivory, white, black and moka. Class1 fire-proof.

**Struktur:** Metall nickelsatiniert, mattweiß und mattschwarz nur für die Boden-Bogenlampe erhältlich.

**Diffusor:** Satiniertes, milchweißes geblasenes Glas und Lampenschirme aus Pongé-Stoff in den Farben: Elfenbein, Weiß, Schwarz und Mokka. Feuerfest Klasse 1.

**Structure:** métal nickel satiné, fourni dans les variantes blanc mat et noir mat uniquement pour le lampadaire en arc.

**Diffuseur:** verre soufflé blanc lait satiné et abat-jour en tissu Pongé dans les coloris blanc, noir, ivoire et moka. Ignifuge classe 1.

**Estructura:** metal níquel satinado, disponible en las variables blanco opaco y negro opaco solo para la versión de pie a arco.

**Difusor:** vidrio soplado blanco leche satinado y pantallas en tejido Pongé en los colores: marfil, blanco, negro y moca. Ignifugo clase 1.

**Структура:** сатинированный никель.

Для торшера, в виде арки, может быть выполнена также в матовом белом или матовом черном цветах.

**Рассеиватель:** дутое матовое стекло молочного белого цвета; абажуры из ткани Pongé белого, черного и темно-коричневого цвета и цвета слоновой кости. Огнестойкая ткань класса 1.



BI: Bianco/White



AV: Avorio/Ivory

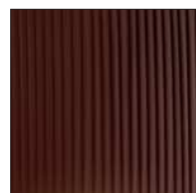

MK: Moka/Moka



NO: Nero/Black

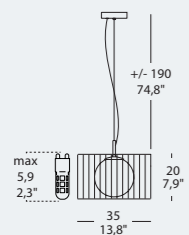

### FOG PLISSÉ SO 35

1 x MAX 4,8W G9 LED

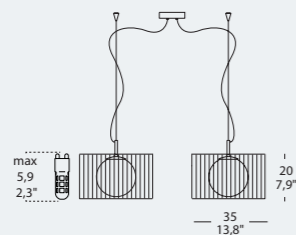

### FOG PLISSÉ SO 35/2

2 x MAX 4,8W G9 LED

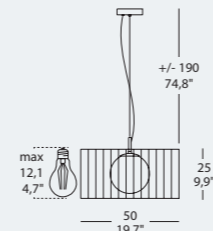

### FOG PLISSÉ SO 50

1 x MAX 13W E27 LED

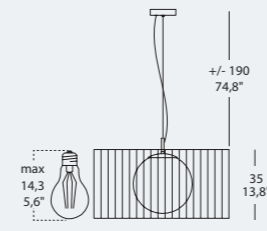
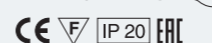

### FOG PLISSÉ SO 70

1 x MAX 17,5W E27 LED

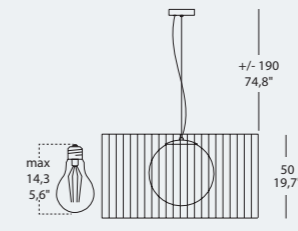

### FOG PLISSÉ SO 100

1 x MAX 17,5W E27 LED

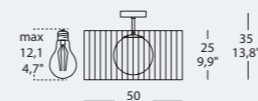

### FOG PLISSÉ PL 50

1 x MAX 13W E27 LED

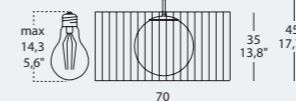

### FOG PLISSÉ PL 70

1 x MAX 17,5W E27 LED

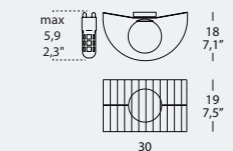

### FOG PLISSÉ PA 30

1 x MAX 4,8W G9 LED

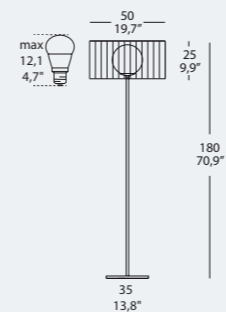

### FOG PLISSÉ TE

1 x MAX 13W E27 LED DIM

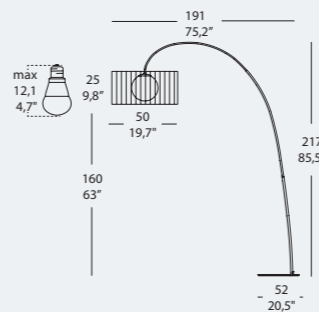
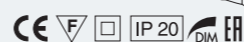

### FOG PLISSÉ TE A

1 x MAX 13W E27 LED DIM

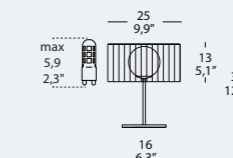
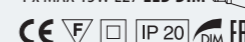

### FOG PLISSÉ CO

1 x MAX 4,8W G9 LED





# RIBBON

design\_Andrea Lazzari

Incontro tra luce e movimento.

The coupling of radiance  
and motion.





Ribbon\_SO 40/2



Ribbon\_TE



Ribbon\_TE A



Ribbon\_CO





Ribbon\_PL 80



Ribbon\_PA 40

# RIBBON

## \_technical data

Ribbon è l'incontro tra la luce e il movimento, tra chiaro e scuro, tra stile moderno e tradizione.

Con Ribbon, Morosini ha voluto riprendere il filo della conoscenza e della sapienza italiana nella lavorazione manuale del tessuto.

Fettucce di stoffa setata, avvolte interamente a mano attorno a una struttura metallica, creano un effetto visivo unico grazie anche all'uso di un diffusore in vetro soffiato che appare e scompare ruotando visivamente attorno al paralume.

Una collezione di lampade formale e sperimentale nello stesso tempo, disponibile in più versioni, per arredare con eleganza e creatività ogni ambiente.

Ribbon is the meeting between light and movement, between light and dark, between modern and traditional style. Through Ribbon, Morosini picked up the thread of knowledge and wisdom in the Italian manual tissue processing. Silky strips of cloth wrapped entirely by hand around a metal structure, create a unique visual effect thanks to the use of a diffuser in blown glass that appears and disappears visually turning around the lampshade. A collection of lamps at the same time formal and experimental, available in several versions, suitable to furnish with elegance and creativity each kind of space.

Ribbon ist das Zusammentreffen zwischen Licht und Bewegung, zwischen Hell und Dunkel, zwischen modernem Stil und Tradition. Mit Ribbon hat Morosini die Erfahrung und das Wissen der manuellen italienischen Stoffverarbeitung wieder aufnehmen wollen. Seidenstoffbänder, die von Hand ganz um eine Metallstruktur gewunden werden, kreieren einen einzigartigen visuellen Effekt auch dank der Anwendung eines Diffusors aus geblasenem Glas, der durch Drehen um den Lampenschirm erscheint und verschwindet. Eine formale und experimentelle Lampenkollektion, die in mehreren Versionen erhältlich ist, um mit Eleganz und Kreativität jede Umgebung einzurichten.

Ribbon représente la rencontre entre la lumière et le mouvement, entre le clair et l'obscur, entre le style moderne et la tradition.

Avec Ribbon, Morosini a voulu reprendre le fil de la connaissance et du savoir italien dans le travail manuel du tissu.

Des bandes d'une étoffe soyeuse, entièrement enveloppés à la main autour d'une structure métallique, créent un effet visuel unique grâce également à l'utilisation d'un diffuseur en verre soufflé qui apparaît et disparaît en pivotant autour de l'abat-jour.

Une collection de lampes à la fois formelle et expérimentale, disponible en plusieurs versions, pour décorer toute pièce avec élégance et créativité.

Ribbon es el encuentro entre la luz y el movimiento, entre claro y oscuro, entre estilo moderno y tradición.

Con Ribbon, Morosini ha querido reanudar el hilo del conocimiento y de la sabiduría italiana en el trabajo manual del tejido.

Tiras de tela de seda, envueltas por el interior a mano alrededor de una estructura metálica, crean un efecto visivo único gracias también al uso de un difusor en vidrio soplado que aparece y desaparece girando alrededor de la pantalla.

Una colección de lámparas formal y experimental al mismo tiempo, disponible en varias versiones, para decorar todo ambiente con elegancia y creatividad.

Ribbon – это встреча света и движения, светлого и темного, современного стиля и традиции.

В своей коллекции Ribbon Morosini решил возобновить итальянские знания и умения в области ручной работы с тканью.

Ленточки из шелковой ткани, вручную обернутые вокруг металлической структуры, создают уникальный визуальный эффект, благодаря рассеивателю, выполненному в виде сферы из дутого стекла, которая кажется пропадающей из вида и вновь появляющейся при вращении вокруг абажура.

Коллекция светильников формальная и в то же время экспериментальная, доступна в различных версиях, для элегантного и креативного оформления любого пространства.

**Struttura:** metallo nichel satinato, disponibile nelle varianti bianco opaco e nero opaco per la sola versione da terra ad arco.

**Frame:** satin finish nickel metal, available also in matt white and matt black only for the arc floor version.

**Struktur:** Metall nickelsatiniert, mattweiß und mattschwarz nur für die Boden-Bogenlampe erhältlich.

**Structure:** métal nickel satinée, fourni dans les variantes blanc mat et noir mat uniquement pour le lampadaire en arc.

**Estructura:** metal níquel satinado, disponible en las variables blanco opaco y negro opaco solo para la versión de pie a arco.

**Структура:** сатинированный никель. Для торшера, в виде арки, может быть выполнена также в матовом белом или матовом черном цветах.

**Diffusor:** milkwhite frosted blown glass and silky ribbon colors: ivory, white, black and moka.

**Diffusor:** verre soufflé blanc lait satiné et abat-jour réalisé avec un ruban soyeux dans les couleurs: Élfenbein, Weiß, Schwarz und Mokka.

**Diffusor:** Satiniertes, milchweißes geblasenes Glas und Lampenschirme aus Seidenbändern in den Farben: Elfenbein, Weiß, Schwarz und Mokka.

**Difusor:** vidrio soplado blanco leche satinado y pantallas de cinta de seda en los colores: marfil, blanco, negro y moca.

**Рассеиватель:** дутое матовое стекло молочного белого цвета; абажуры из ленточек из шелковой ткани могут быть выполнены в цвете слоновой кости, белом, черном или темно-коричневом цветах.



BI: Bianco/White



AV: Avorio/Ivory



MK: Moka/Moka



NO: Nero/Black

**RIBBON SO 40**  
1 x MAX 4,8W G9 LED

**RIBBON SO 40/2**  
2 x MAX 4,8W G9 LED

**RIBBON SO 60**  
1 x MAX 13W E27 LED

**RIBBON SO 80**  
1 x MAX 17,5W E27 LED

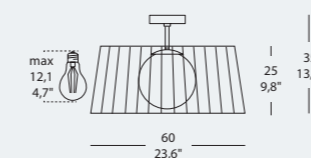

**RIBBON PL 60**  
1 x MAX 13W E27 LED

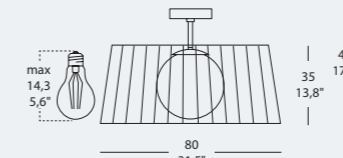

**RIBBON PL 80**  
1 x MAX 17,5W E27 LED

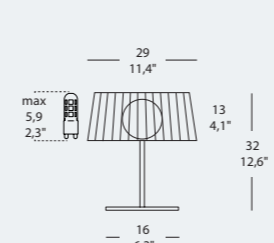

**RIBBON CO**  
1 x MAX 4,8W G9 LED

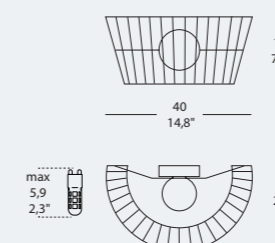

**RIBBON PA 40**  
1 x MAX 4,8W G9 LED

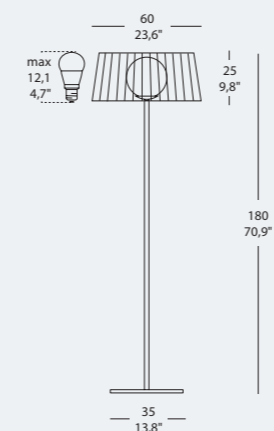

**RIBBON TE**  
1 x MAX 13W E27 LED DIM

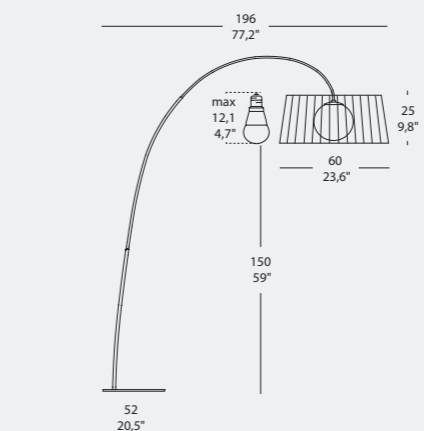

**RIBBON TE A**  
1 x MAX 13W E27 LED DIM





# DIAMOND

design\_Sandro Santantonio



Una gemma di design.

A splendid design gem.



Diamond\_SO 120

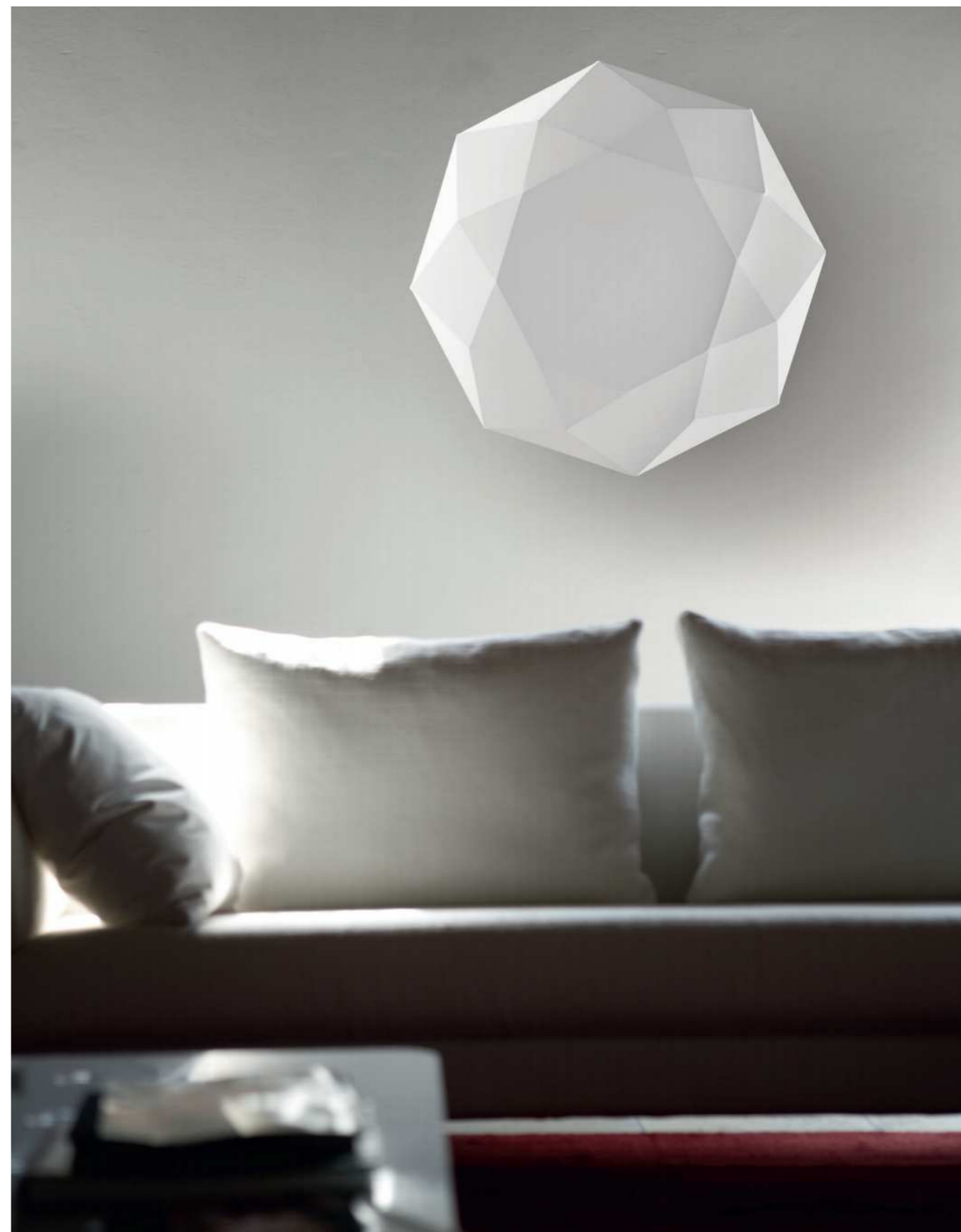

Diamond\_PP 80



# DIAMOND

## \_technical data

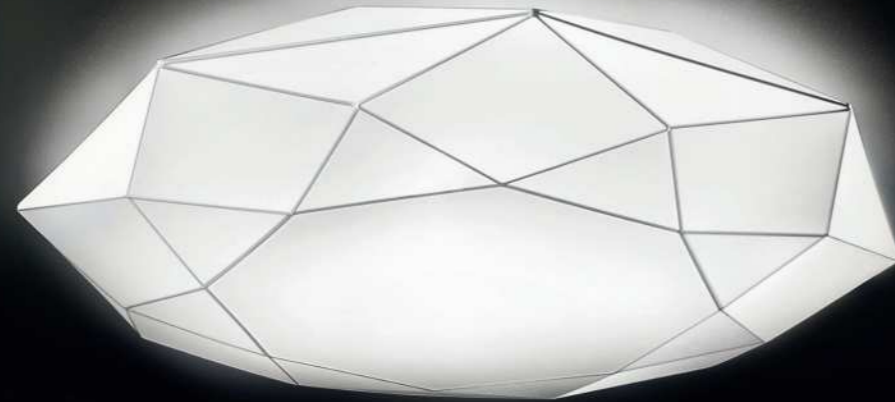

Una lampada dall'eleganza purissima. Una gemma di design incastonata nello spazio. La collezione Diamond comprende molteplici tagli e dimensioni, che rappresentano le mille facce della stessa brillante idea. Come lampada a sospensione, Diamond assume l'aspetto di una nuvola di luce, lasciando trasparire tutta la leggerezza del suo tessuto. Come lampada da parete, infine, Diamond cattura immediatamente lo sguardo per la sua rara originalità. Dedicato all'arredamento moderno, un oggetto di design in grado di brillare di luce propria.

A lamp of pure elegance. A design gem set in space. The Diamond collection includes various cuts and sizes, representing the many faces of the same brilliant idea. As pendant lamp, Diamond seems to be a cloud of light, that reveals all the lightness of the fabric. In conclusion, Diamond, as wall lamp, catches immediately the eye thanks to its rare originality. A design element that shines in its own light, dedicated to modern furniture.

Eine Lampe mit reiner Eleganz. Ein im Raum eingelassener Design-Edelstein. Die Kollektion Diamond schließt zahlreiche Schritte und Dimensionen ein, die die tausenden Facetten derselben brillanten Idee darstellen. Als Hängelampe übernimmt Diamond den Aspekt einer Lichtwolke und lässt die ganze Leichtigkeit ihres Gewebes durchscheinen. Als Wandlampe hingegen zieht Diamond dank ihrer seltenen Originalität sofort den Blick auf sich. Sie ist dem modernen Einrichtungsstil gewidmet, ein Designobjekt das mit eigenem Licht glänzt.

Une lampe d'une élégance purissime. Une étoile de design enchâssée dans l'espace. La collection Diamond présente de nombreuses tailles et dimensions, qui représentent les mille facettes de la même idée brillante. En tant que lampe à suspension, Diamond prend l'aspect d'un nuage de lumière, laissant apparaître toute la légèreté de son tissu. Enfin, en tant qu'applique, l'originalité rare de Diamond capture immédiatement le regard. Dédié à la décoration moderne, cet objet de design est en mesure de briller de ses propres feux.

Una lámpara de elegancia purísima. Una joya de diseño engastada en el espacio. La colección incluye múltiples cortes y dimensiones, que representan las mil caras de la misma idea brillante. Como lámpara colgante, Diamond toma la apariencia de una nube de luz, dejando transparecer toda la ligereza de su tejido. Como lámpara de pared, finalmente, Diamond cautiva inmediatamente la atención por su rara originalidad. Dedicado a la decoración moderna, un objeto de diseño puede brillar por su propia luz.

Светильник абсолютной элегантности. Это жемчужина дизайна, вставленная в оправу пространства. Коллекция Diamond содержит в себе множество граней и размеров, которые представляют тысячу аспектов одной и той же превосходной идеи. Подвесной светильник Diamond принимает форму облака света, позволяя просвечивать всю легкость ткани. Настенный светильник Diamond мгновенно притягивает взгляд благодаря своей редкой оригинальности. Эти элементы декора, предназначенные для установки в современных интерьерах и способные дарить свой блестящий свет.

**Struttura:** metallo bianco opaco.  
**Diffusore:** lycra elasticizzata bianca, sfoderabile e lavabile.

**Frame:** matt white metal.  
**Diffuser:** white stretch removable and washable lycra.

**Struktur:** Metall mattweiß.  
**Diffusor:** Weißes, elastisches Lycra, abzieh-und waschbar.

**Structure:** métal blanc mat.  
**Diffuseur:** lycra élastique blanc, déhoussable et lavable.

**Estructura:** metal blanco opaco.  
**Difusor:** lycra elástica blanca, desenfundable y lavable.

**Структура:** белый блестящий металл.  
**Рассеиватель:** белая эластичная лайкра, которая снимается и стирается.

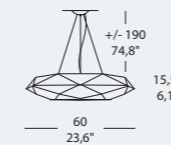

**DIAMOND SO 60**  
2 x Max 10W E27 LED  
CE F IP20 EAC

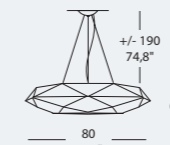

**DIAMOND SO 80**  
3 x Max 17,5W E27 LED  
CE F IP20 EAC

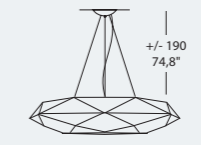

**DIAMOND SO 120**  
3 x Max 17,5W E27 LED  
CE F IP20 EAC

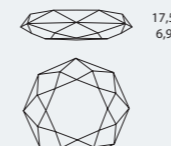

**DIAMOND PP 60**  
2 x Max 10W E27 LED  
CE F IP20 EAC

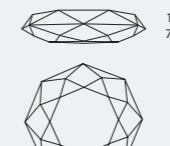

**DIAMOND PP 80**  
3 x Max 17,5W E27 LED  
CE F IP20 EAC

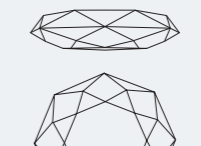

**DIAMOND PP 120**  
3 x Max 17,5W E27 LED  
CE F IP20 EAC

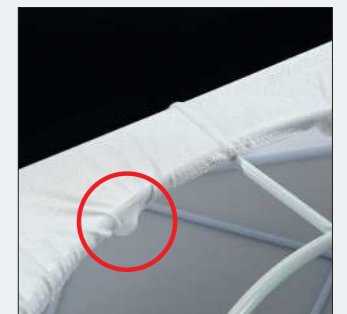





# IN & OUT

design\_ Andrea Lazzari

Delicati volumi contemporanei.

Refined contemporary lines.





# IN & OUT

\_technical data

**Design & Artigianato, Semplicità & Eleganza, Tessuto & Luce:** in una parola, In & Out. L'essenzialità estetica della lampada nasconde in verità una sofisticata ricerca progettuale e una sapienza produttiva ai massimi livelli.

Le parti metalliche centrali sono rimovibili e possono essere montate in due diverse posizioni, in modo da poter cambiare il disegno centrale della lampada.

Il design diventa così unico, esclusivo, arredando con la stessa forza espressiva di un'opera d'arte contemporanea.

**Design et Artisanat, Simplicité et Élégance, Tissu et Lumière :** en un mot, In & Out. Le caractère esthétique essentiel de la lampe cache en vérité une recherche conceptuelle sophistiquée et une capacité de production au plus haut niveau.

Les pièces métalliques centrales sont amovibles et elles peuvent être montées dans deux positions différentes, afin de changer le design central de la lampe. Ainsi le design devient unique, exclusif, décorant avec la même force d'expression qu'une œuvre d'art contemporaine.

**Design & Craftsmanship, Elegance & Simplicity, Fabric & Light:** in a word, In & Out. The aesthetic essentiality of the lamp actually hides a sophisticated design research and a productive knowledge at the highest levels.

The central metal parts are removable and can be assembled in two different positions, in order to change the central drawing of the lamp.

In this way, the design becomes unique and exclusive, furnishing with the same expressive power of a contemporary artwork.

**Design & Artesanía, Simplicidad & Elegancia, Tejido & Luz:** en pocas palabras, In & Out. La esencialidad estética de la lámpara esconde en realidad una sofisticada búsqueda proyectual y una sabiduría productiva a los máximos niveles.

Los componentes metálicos centrales son amovibles y se pueden montar de dos maneras diferentes, ofreciendo la posibilidad de cambiar el diseño central de la lámpara.

El design se vuelve así único, exclusivo, decorando con la misma fuerza expresiva de una obra de arte contemporánea.

**Design & Handwerk, Einfachheit & Eleganz, Stoff & Licht.** In einem Wort: In & Out. Die ästhetische Grundsätzlichkeit dieser Lampe verbirgt in Wirklichkeit eine ausgeklügelte Konstruktion und ein Produktionswissen auf höchster Ebene. Die mittigen Metallteile sind abnehmbar und können zur Variation des zentralen Lampenmusters in zwei verschiedenen Stellungen montiert werden. Das Design wird dadurch einzigartig, exklusiv und richtet mit derselben Ausdruckskraft eines zeitgenössischen Kunstwerks ein.

**Дизайн и Архитектура, Простота и Элегантность, Ткань и Свет:** одним словом, In & Out. За эстетической сущности светильника скрываются, в действительности, современная проектно-исследовательская работа и продуктивные знания на самом высоком уровне. Центральные металлические части снимаются и могут быть установлены в двух различных позициях для изменения дизайна центральной части лампы. Таким образом, дизайн становится уникальным и единственным, способным украсить интерьер с такой же силой экспрессии, как и произведение современного искусства.

**Struttura:** metallo bianco lucido.  
**Diffusore:** lycra elasticizzata bianca, sfoderabile e lavabile.

**Frame:** white polished finish metal.  
**Diffuser:** white stretch removable and washable lycra.

**Struktur:** Metall glänzend Weiß.  
**Diffusor:** Weißes, elastisches Lycra, abzieh-und waschbar.

**Structure:** métal blanc brillant.  
**Diffuseur:** lycra élastique blanc, déhoussable et lavable.

**Estructura:** metal blanco brillante.  
**Difusor:** lycra elástica blanca, desenfundable y lavable.

**Структура:** белый блестящий металл.  
**Рассеиватель:** белая эластичная лайкра, которая снимается и стирается.



Bl: Bianco/White

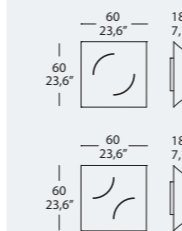

**IN & OUT PP 60 FL**

2 x Max 10W E27 LED

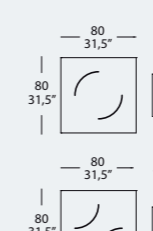

**IN & OUT PP 80 FL**

3 x Max 17,5W E27 LED

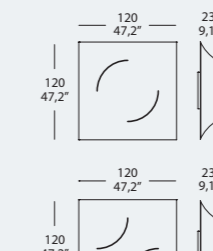

**IN & OUT PL 120 FL**

3 x Max 17,5W E27 LED







EGG  
design\_Morosini

Il piacere di una sorpresa  
di luce.

A pleasant surprise of light.



Egg\_SO 1



Egg\_SO 2



# EGG

## \_technical data

Nella sua semplicità, la lampada Egg sa essere formale e spiazzante nello stesso tempo. Un vero tocco di eleganza anticonformista che quando si illumina si schiude, mostrando tutta la raffinatezza del vetro soffiato satinato. Un design naturale, essenziale, ma assolutamente non convenzionale, dedicato all'arredamento moderno.

Dans sa simplicité, la lampe Egg sait être à la fois formelle et étonnante. Une véritable touche d'élégance anticonformiste qui, lorsqu'elle s'allume, s'entrouvre pour dévoiler tout le raffinement du verre soufflé satiné. Un design naturel, essentiel, mais absolument non conventionnel, dédié à la décoration moderne.

The lamp Egg can be at the same time formal and unexpected, thanks to its simplicity. A real touch of nonconformist elegance which blossoms, showing the extreme refinement of blown glass when the light is on. A natural, essential, but unconventional design, dedicated to modern decor.

En su simplicidad, la lámpara Egg sabe ser formal e inquietante al mismo tiempo. Un verdadero toque de elegancia inconformista que cuando se ilumina se abre mostrando toda la sofisticación del vidrio soplado. Un design natural, esencial, pero absolutamente no convencional, dedicado al mobiliario moderno.

In ihrer Einfachheit weiß die Lampe EGG auch formal und gleichzeitig beeindruckend zu sein. Ein wirklich antikonformistischer Hauch von Eleganz, wenn sie erleuchtet ist und ihre ganze Eleganz des satinierten geblasenen Glases zeigt. Ein natürliches, essentielles Design das absolut nicht konventionell ist und der modernen Einrichtung gewidmet ist.

В своей простоте светильник Egg умеет быть формальным, но в то же время сбивающим с толку. Настоящий штрих анти-конформистской элегантности, которая проявляется во включенном состоянии, демонстрируя утонченность сатирированного дутого стекла. Естественный, но абсолютно необычный дизайн предназначен для современных интерьеров.

**Struttura:** metallo cromato.

**Diffusore:** vetro soffiato bianco latte satinato.

**Frame:** chrome-metal.

**Diffuser:** milkwhite blown glass in satin finish.

**Struktur:** Metall verchromt.

**Diffusor:** Satiniertes, milchweißes geblasenes Glas.

**Structure:** métal chromé.

**Diffuseur:** verre soufflé blanc lait satiné.





**Estructura:** metal cromado.

**Difusor:** vidrio soplado blanco leche satinado.

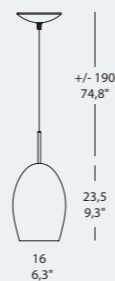



**Структура:** хромированный металл.

**Рассеиватель:** молочно-белое сатирированное дутое стекло.

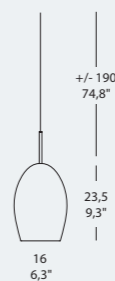







**EGG/S01**  
1 x Max 10W E27 LED   
CE    

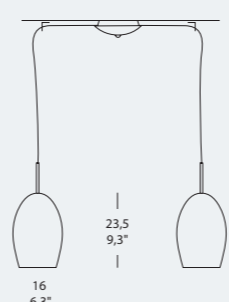





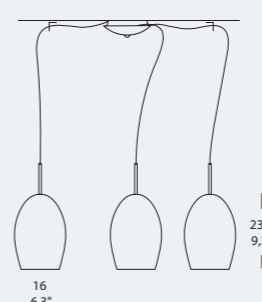

**EGG/SO S/R**  
1 x Max 10W E27 LED   
CE    

Elemento a sospensione senza rosone idoneo per i rosone e i binari della collezione Versatile (pag. 31-32).  
Pendant lamp without canopy suitable for canopies and tracks of the Versatile collection (page 31-32).







**EGG/S02**  
2 x Max 10W E27 LED   
CE    

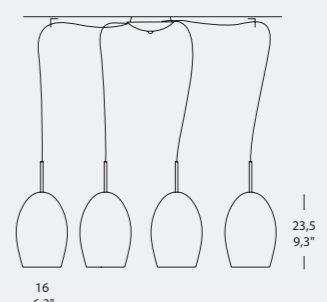

**EGG/S03**  
3 x Max 10W E27 LED   
CE    



**EGG/S04**  
4 x Max 10W E27 LED   
CE    

# SUNRISE ECO

design\_Morosini

Scoprire orizzonti luminosi.

Discovering radiant horizons.





Sunrise eco\_PA 390 LED



Sunrise eco\_PA 50 G9



Sunrise eco\_PA 270 LED



Sunrise eco\_PA 510 LED



# SUNRISE ECO

## \_technical data

Una lampada dal design essenziale, minimale, discreto come il primo sole che sorge all'orizzonte. Frutto di un restyling che ne ha ulteriormente raffinato l'aspetto, mettendo in luce nello stesso tempo tutta la sapienza tecnica di Morosini, oltre che la sua attenzione per l'ambiente.  
Sunrise Eco è infatti disponibile anche a LED.  
Una soluzione brillante, quanto ecocompatibile.

A lamp with an essential, minimalist and moderate design as the first sunrise on the horizon. It is the result of a restyling that has further improved the look of the lamp, highlighting at the same time all the Morosini know how, as well as the attention to the environment.  
Sunrise Eco is also available in LED.  
A solution as brilliant as eco-friendly.

Eine Lampe mit einem essentiellen, minimalen Design, diskret wie der erste Sonnenstrahl am Horizont. Ergebnis eines Restylings das seinen Aspekt noch verfeinert hat und gleichzeitig das ganze technische Wissen und auch das Umweltbewusstsein von Morosini ans Licht gebracht hat.  
Sunrise Eco ist auch in der LED-Ausführung erhältlich.  
Eine brillante und umweltbewusste Lösung.

Une lampe design et essentielle, minimale, discret comme le soleil qui se lève à l'horizon. Fruit d'un restyling qui en a ultérieurement raffiné l'aspect, en dévoilant en même temps tout le savoir technique de Morosini, ainsi que l'attention qu'elle porte à l'environnement.  
Sunrise Eco est en effet également disponible dans la version à LED. Une solution brillante et écologique.

Una lámpara de design esencial, minimal, discreto como el primer sol que surge en el horizonte. Fruto de un restyling que ha refinado ulteriormente el aspecto, poniendo en luz al mismo tiempo toda la sabiduría técnica de Morosini, además que su atención al ambiente.  
Sunrise Eco está en efecto disponible también en versión LED. Una solución brillante y ecocompatible.

Светильник сдержанного дизайна, простого и минималистического, как первые лучи солнца, поднимающегося над горизонтом. Результат модернизации, полностью изменивший его внешний вид, показав, наряду с бережным отношением к внешней среде, все технические знания Morosini.  
Модель Sunrise Eco доступна также в версии LED. Это превосходное, эко-совместимое решение.

**Struttura:** acciaio inox satinato o bianco opaco o nero opaco.  
**Diffusore:** vetro satinato.

**Frame:** satin finish stainless steel or matt white or matt black.  
**Diffuser:** satin glass

**Struktur:** Satiniertes Edelstahl, oder mattweiß, oder mattschwarz.  
**Diffusor:** Satiniertes Glas.

**Structure:** acier inox satiné ou blanc mat ou noir mat.  
**Diffuseur:** verre satiné.

**Estructura:** acero inox satinado o blanco opaco o negro opaco.  
**Difusor:** vidrio satinado.

**Структура:** нержавеющей сталь сатинированная или с белой матовой или черной матовой отделками.  
**Рассеиватель:** Сатинированное стекло.

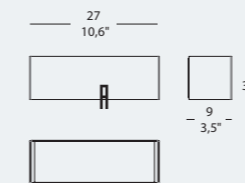

**SUNRISE ECO PA270 LED**  
7,4W 1344Lm 3000K  
Cri>80 220/240Vac 50-60Hz **LED**  
CE F IP 40 ADA ENEC

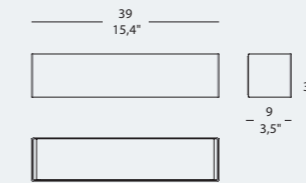

**SUNRISE ECO PA390 LED**  
14,9W 2678Lm 3000K  
Cri>80 220/240Vac 50-60Hz **LED**  
CE F IP 40 ADA ENEC

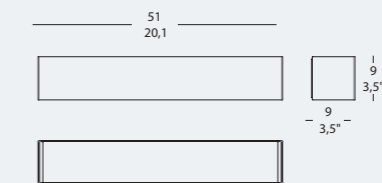

**SUNRISE ECO PA510 LED**  
22,2W 4032Lm 3000K  
Cri>80 220/240Vac 50-60Hz **LED**  
CE F IP 40 ADA ENEC

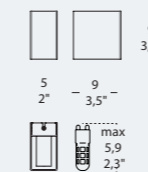

**SUNRISE ECO PA50 G9**  
1 x MAX 4,8W G9 **LED**  
CE F IP 20 ADA ENEC

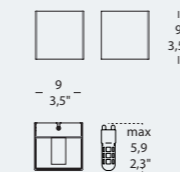

**SUNRISE ECO PA90 G9**  
1 x MAX 4,8W G9 **LED**  
CE F IP 20 ADA ENEC

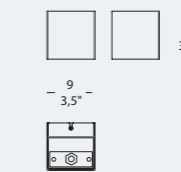

**SUNRISE ECO PA90 LED**  
9,4W 1394Lm 3000K  
Cri>80 220/240Vac 50-60Hz **LED**  
9,4W 1312Lm 2700K  
Cri>80 220/240Vac 50-60Hz **LED**  
CE F IP 20 ADA ENEC





# BIA

design\_ Borri Manuel  
Diagora Design

La riscoperta del  
passato che illumina  
il presente.

The rediscovery of  
the past that enlightens  
the present.





Bia\_CORINTO SMALL, ATENE SMALL, ARGO SMALL + RO1

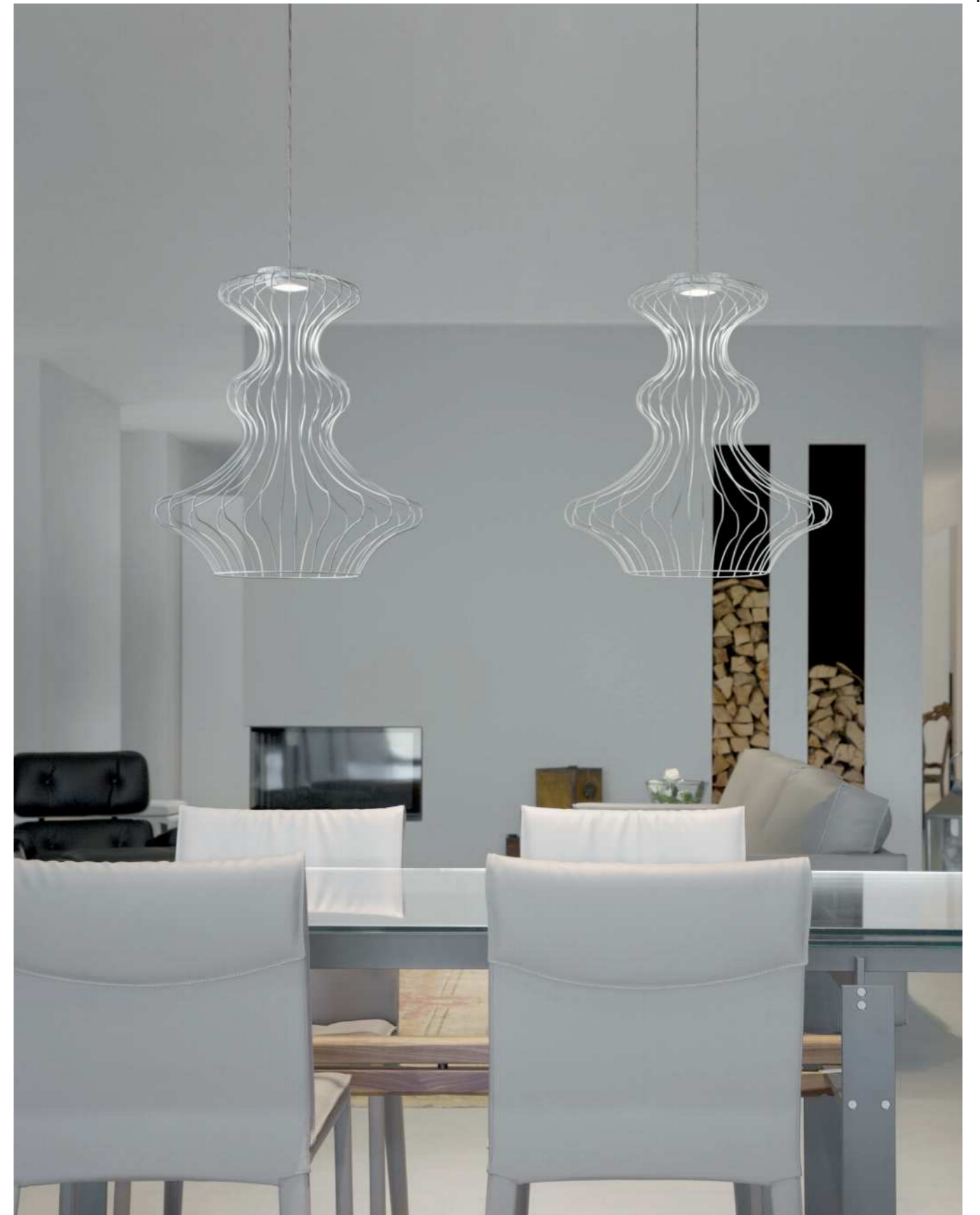

Bia\_ATENE BIG + RO2





Bia\_CORINTO SMALL + RO6

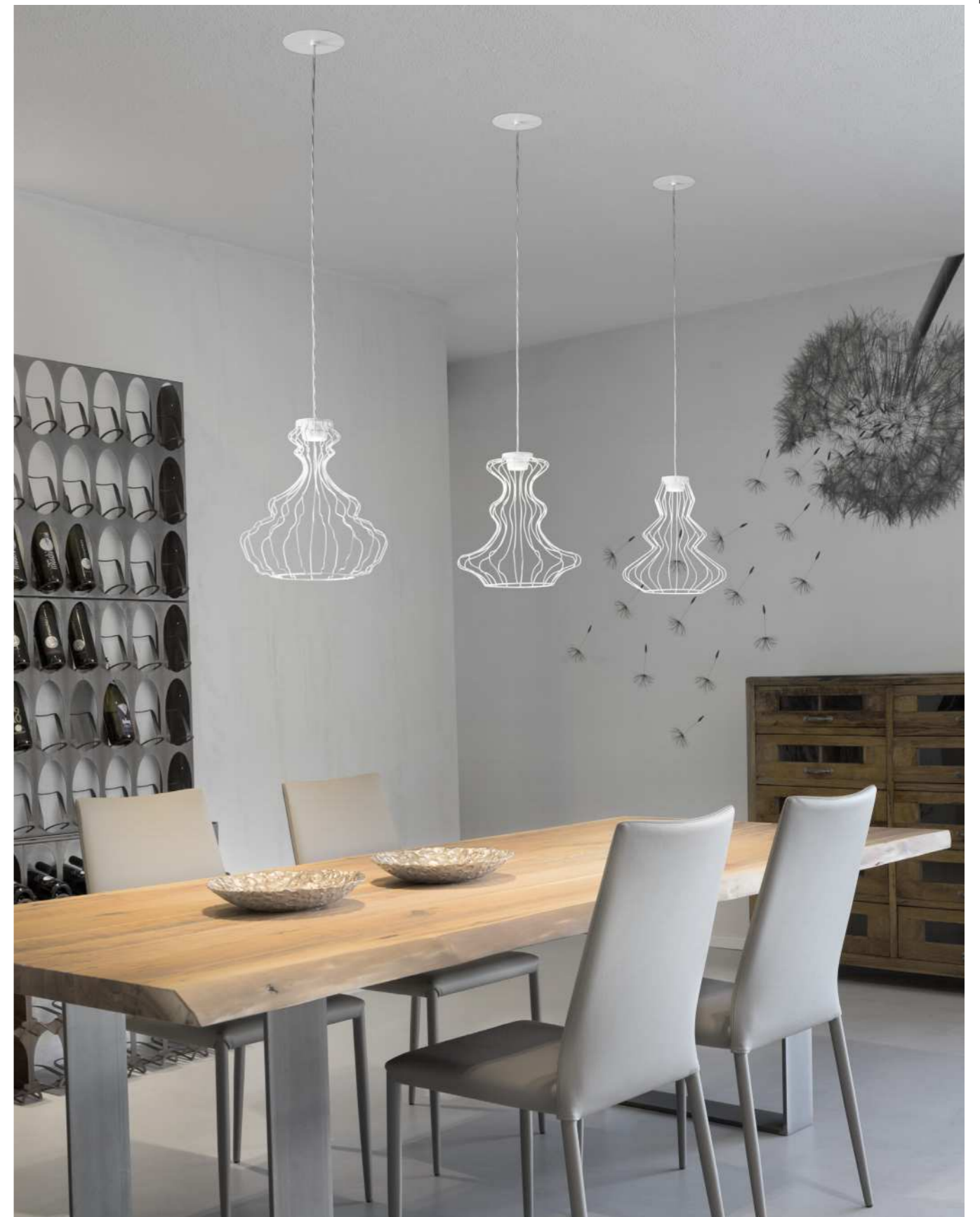

Bia\_CORINTO SMALL, ATENE SMALL, ARGO SMALL + IN1





Bia\_ esempio di composizione con RO12 / example of composition with RO12



Bia conduce ai giorni nostri i fasti dell'immortale cultura ellenica. Concepito come elemento di illuminazione decorativa contemporanea, affonda le sue radici nelle sinuose forme degli antichi vasi greci, icone di una civiltà che dal passato sino ad oggi ha rappresentato un faro per l'umanità. Bia viene realizzata in due misure, tre disegni e quattro differenti finiture. In ogni sua declinazione rispetta le parti che componevano i vasi ellenici, dall'orlo al piede, per offrire un'esperienza sensoriale caratterizzata da un gusto e una raffinatezza senza tempo.

Bia leads the glories of the immortal Hellenic culture to the present day. Conceived as an element of contemporary decorative lighting, it traces its roots back to the sinuous shapes of the ancient Greek vases, symbols of a civilization that has been a lighthouse for humanity from the past to this day. Bia is available in two sizes, three styles and four different finishes. In all versions it complies with the parts from which the Greek vases were made. From the lip to the foot, it offers a sensory experience characterised by timeless taste and refinement.

Bia führt den Ruhm der unsterblichen griechischen Kultur in die heutige Zeit. Als ein Element der zeitgenössischen dekorativen Beleuchtung konzipiert, hat Bia seine Wurzeln in den gewundenen Formen der antiken griechischen Vasen, Symbolen einer Zivilisation, die ein Leuchtturm für die Menschheit von der Vergangenheit bis zur Gegenwart ist. Bia ist in zwei Größen, drei Formen und vier verschiedenen Oberflächen erhältlich. In allen Versionen folgt Bia genau allen Teilen der griechischen Vasen, von dem Rand bis zum Fuß, um ein sinnliches Erlebnis zu bieten, das durch zeitlosen Geschmack und Raffinesse gekennzeichnet ist.

Bia mène à nos jours les fastes de l'immortelle culture hellénique. Conçue comme élément d'éclairage décoratif contemporain, elle plonge ses racines dans les formes sinueuses des anciens vases grecs, icônes d'une civilisation qui a été un phare pour l'humanité du passé à nos jours. Bia se réalise en deux mesures, trois dessins et quatre finitions différentes. Dans chacune des déclinaison, elle respecte les parties qui composent les vases helléniques, de laèvre au fond, pour offrir une expérience sensorielle qui est caractérisée par un goût et un raffinement intemporel.

Bia trae a nuestros días los fastos de la inmortal cultura helénica. Concebida como elemento de iluminación decorativa contemporáneo, hunde sus raíces en las formas sinuosas de las antiguas vasijas griegas, iconos de una civilización que ha representado un faro para la humanidad, del pasado hasta hoy. Bia se realiza en dos medidas, tres diseños y cuatro acabados diferentes. En cada su declinación respeta las partes que formaban las vasijas helénicas, del borde a la basa, para ofrecer una experiencia sensorial caracterizada por un gusto y una exquisitez sin tiempo.

Bia относит нас к бессмертной греческой культуре. Задуманный как элемент современного декоративного освещения, он берёт своё начало от форм древнегреческих ваз, символов цивилизации, которая и по сей день остаётся маяком для человечества. Bia выпускается в двух размерах, трёх стилях и четырёх различных отделках. Во всех версиях он соответствует элементам, из которых изготовлены греческие вазы.

**Struttura:** rosone bianco – altre parti in metallo nelle colorazioni: bianco opaco, nero opaco, oro opaco, rame opaco.

**Frame:** white canopy – other metal parts in the colors: matt white, matt black, matt gold, matt copper.

**Struktur:** Baldachin: weiß – die anderen Metallteile in den Farben: Mattweiß, Mattschwarz, Mattgold, Mattkupfer.

**Structure:** rosette blanche – autres parties métalliques dans les couleurs: blanc mat, noir mat, or mat, cuivre mat.

**Estructura:** florón blanco – otras partes de metal en los colores: blanco mate, negro mate, oro mate, cobre mate.

**Структура:** белый розон, остальные металлические части – матовый чёрный либо матовое золото.

**Diffusore:** Policarbonato satinato

**Diffuser:** Polycarbonate satin finish.

**Diffusor:** Satin Polycarbonat

**Diffusor:** Polycarbonate satiné.

**Difusor:** Policarbonato satinado.

**Рассеиватель:** Матовый поликарбонат

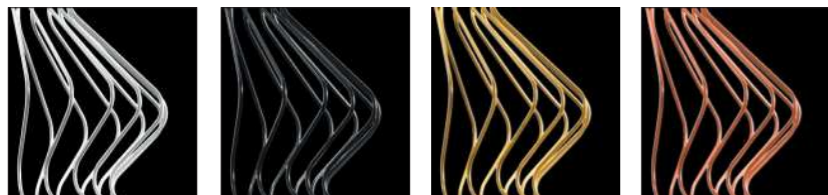

06: Bianco / White

07: Nero / Black

22: Oro / Gold

29: Rame / Copper

### SOSPENSIONI (CAVO STANDARD CM 350 + DECENTRAMENTO)/PENDANT LAMPS (STANDARD CABLE CM 350 + OFF CENTRE POSITION)

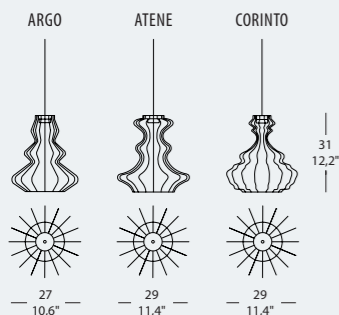

#### BIA SO S/R SMALL

8W 632Lm 2700K Cri>80 230 Vac 50-60hz LED

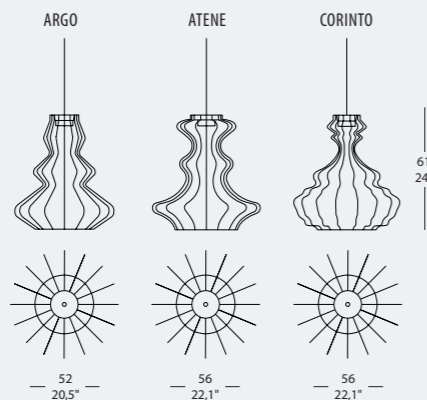

#### BIA SO S/R BIG

12W 1020Lm 2700K Cri>80 230 Vac 50-60hz LED



### ROSONI/CANOPIES

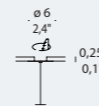

#### BIA IN-1

ROSONE A INCASSO A 1 LUCE  
1-LIGHT RECESSED CANOPY



#### BIA RO-1

ROSONE A 1 LUCE  
1-LIGHT CANOPY

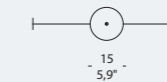
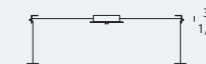

#### BIA RO-2

ROSONE A 2 LUCI  
2-LIGHT CANOPY

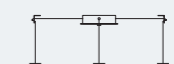

#### BIA RO-3

ROSONE A 3 LUCI  
3-LIGHT CANOPY

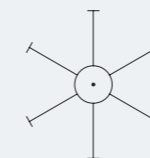

#### BIA RO-6

ROSONE A 6 LUCI  
6-LIGHT CANOPY

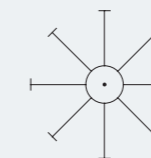
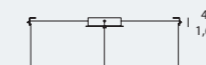

#### BIA RO-8

ROSONE A 8 LUCI  
8-LIGHT CANOPY

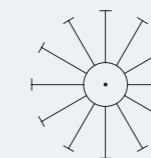
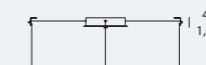

#### BIA RO-12

ROSONE A 12 LUCI  
12-LIGHT CANOPY



### ESEMPI DI COMPOSIZIONE/EXAMPLES OF COMPOSITION

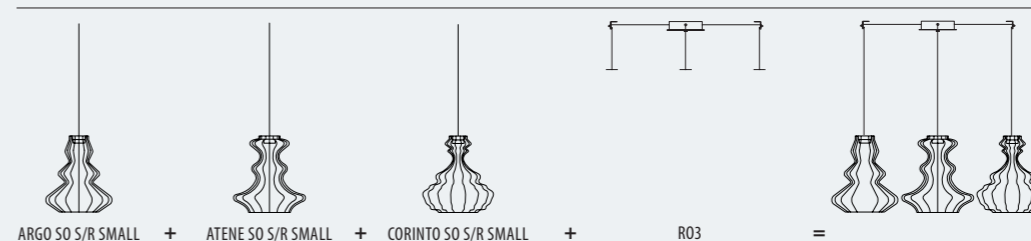
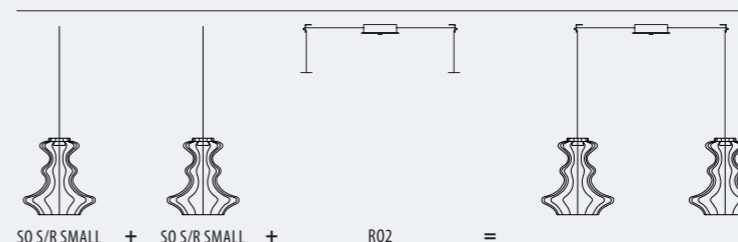





# MEMORIA

design\_Dima Loginoff

Art Deco in chiave  
moderna e chic.

Art Deco on a modern  
and chic take.

























S1-A0 S1-A1 S1-A2 S1-A3 S1-A4 S1-A5 S1-A6



S2-A0 S2-A1 S2-A2 S2-A3 S2-A4 S2-A5 S2-A6



C1-A0 C1-A1 C1-A2 C1-A3 C1-A4 C1-A5 C1-A6



C2-A0 C2-A1 C2-A2 C2-A3 C2-A4 C2-A5 C2-A6

Dettagli/Details

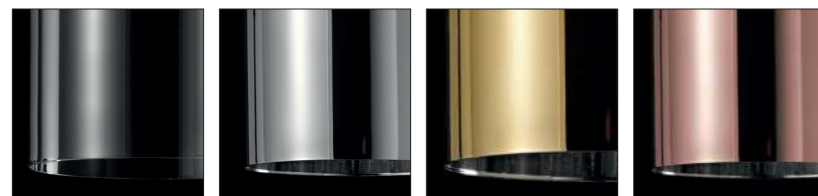

Trasparente/  
Transparent Cromo/  
Chrome Oro/  
Gold Rame/  
Copper

Cavo/Cable

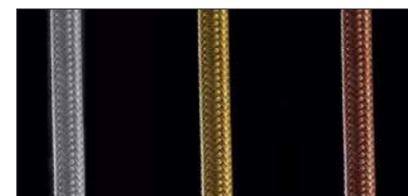

Cromo/  
Chrome Oro/  
Gold Rame/  
Copper

# MEMORIA

## \_technical data

Stile internazionale e ricercatezza italiana, per una collezione di lampade a sospensione che rimanda all'estetica dell'Art Déco, rivisitata in chiave più moderna e chic. Disponibile in versione singola o multipla, sia circolare che lineare, Memoria può acquisire ulteriore esclusività giocando con i volumi dei suoi elementi e le diverse tonalità dei diffusori in vetro: trasparenti o metallizzati in oro, cromo e rame, abbinati a cavi rivestiti in calza metallica dello stesso colore. L'effetto ottenuto con i diffusori metallizzati, definito "trans-mirror", esalta il fascino della lampada generando a luce accesa sofisticate trasparenze. La versione con diffusore trasparente invece, racchiude al suo interno una luminosa sfera in vetro soffiato, testimone della cura del dettaglio tipica del brand. Tutta la collezione utilizza sorgenti a LED.

Style international et raffinement italien, pour une collection de lampes à suspension qui renvoie à l'esthétique de l'Art Déco, revue sous un jour plus moderne et chic. Fournie dans la version simple ou multiple, circulaire et linéaire, Memoria peut devenir plus exclusive en jouant avec les volumes de ces éléments et les différentes tonalités des diffuseurs en verre: transparents ou métallisés en or, chrome et cuivre, associés à des câbles revêtus d'une gaine métallique de la même couleur. L'effet obtenu avec les diffuseurs métallisés, défini "trans-mirror", exalte le charme de la lampe en générant des transparences sophistiquées lorsqu'elle est allumée. En revanche, la version avec un diffuseur transparent, contient une sphère lumineuse en verre soufflé, témoignant du soin du détail typique de la marque. Toute la collection utilise des sources à LED.

With a reference to Art Decò, revisited in a more modern and chic key, this collection of pendant lamps is the representation of International style and Italian preciousness. Available in single and multiple, as well as in circular and linear versions, Memoria can gain additional exclusivity playing with the volumes of its elements and the different shades of glass diffusers: transparent or metalized in gold, chrome and copper, combined with cables of the same color, coated with metal braid. The "trans-mirror" effect, obtained with the metalized diffusers, enhances the charm of the lamp creating sophisticated transparencies when the light is on. The version with the transparent diffuser, instead, contains within it a bright ball in blown glass, a witness of the attention to detail, that is a typical element of the brand. The entire collection uses LED sources.

Estilo internacional y elegancia italiana para una colección de lámparas de suspensión que recuerda la estética del Art Déco revisitada en clave más moderna y chic. Disponible en versión única o múltiple, tanto circular como lineal, Memoria puede adquirir más exclusividad jugando con los volúmenes de sus elementos y los varios tonos de los difusores en vidrio: transparentes o metalizados en oro, cromo y cobre, combinados con cables forrados en trenza metálica del mismo color. El efecto obtenido con los difusores metalizados, definido "trans-mirror", exalta el encanto de la lámpara generando sofisticadas transparencias con la luz encendida. La versión con difusor transparente en cambio, encierra en su interior una luminosa esfera de vidrio soplado, testigo del cuidadoso detalle, típico de la marca. Toda la colección utiliza fuentes de LED.

Internationaler Stil und italienische Raffinesse für eine Lampenkollektion mit Abhängung, die sich an die Ästhetik des Art Deco in moderner und eleganter Form anlehnt. Sie ist erhältlich in einfacher oder mehrfacher Version, sowohl kreisförmig als auch linear. Memoria gewinnt zusätzliche Exklusivität durch das Spiel mit dem Volumen seiner Elemente und den unterschiedlichen Tonalitäten (transparent oder metallisiert in Gold, verchromt und Kupfer) der Glas-Lampenschirme im Einklang mit den umkleideten Kabeln in der gleichen Farbe. Der sogenannte "Spiegel-Effekt" der durch die metallisierten Diffusoren erzielt wird, erhöht den Charme der Lampe die bei eingeschaltetem Licht anspruchsvolle Transparenz erzeugt. Die Ausführung mit transparentem Diffusor hingegen, umschließt im Inneren eine helle Kugel in geblasenem Glas. Der Beweis für die Liebe zum Detail, typisch für unsere Marke. Die ganze Kollektion ist exklusiv mit LED-Lichtquellen ausgestattet.

Интернациональный стиль и итальянская изысканность, для роскошной коллекции подвесных светильников, которая возвращает к эстетике стиля ар-деко, переосмысленной в современном ключе. Предоставлена в виде одиночного светильника или группы светильников, как с линейным, так и с круговым расположением, Memoria может приобрести дополнительную исключительность, играя с объемами своих элементов и разными оттенками своих рассеивателей из стекла: прозрачных или металлизированных, доступных в следующих цветах: золото, хром и медь; с проводами, в металлической оплетке такого же цвета. Эффект, полученный с применением металлизированных рассеивателей, названный "trans-mirror", подчеркивает обаяние светильника, создавая во включенном состоянии изысканную прозрачность. Версия с прозрачным рассеивателем, напротив, заключает внутри себя светящуюся сферу из дутого стекла - свидетеля заботы о деталях, типичной для бренда. Во всей коллекции в качестве источника света используется LED.

**Struttura:** metallo bianco opaco, con particolari in cromo, oro e rame. **Diffusore:** vetro trasparente, cromo, oro e rame, in diverse combinazioni.

**Struktur:** metall mattweiß, Details in Chrom, Gold und Kupfer. **Diffusor:** Glas transparent, Chrom, Gold und Kupfer, verschiedene Kombinationen möglich.

**Estructura:** metal blanco opaco, con detalles de cromo, oro y cobre. **Difusor:** vidrio transparente, cromo oro y cobre, en varias combinaciones.

**Frame:** matt white metal, with details in chrome, gold and copper. **Diffuser:** glass in transparent, chrome, gold and copper, in various combinations.

**Structure:** métal blanc opaque, avec des détails en chrome, or et cuivre. **Diffuseur:** verre transparent, chrome, or et cuivre, dans différentes combinaisons.

**Структура:** белый матовый металл с деталями, выполненными в следующих расцветках: хром, золото и медь. **Рассеиватель:** возможные расцветки: прозрачный, хром, золото и медь, в различных сочетаниях.

SOSPENSIONI (CAVO STANDARD CM 200)/PENDANT LAMPS (STANDARD CABLE CM 200)

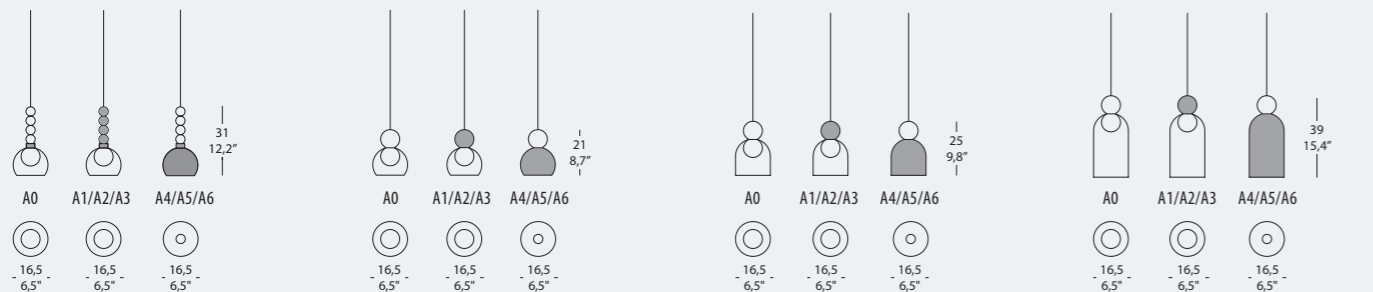

**MEMORIA S1**  
4,4W 640 Lm 3000K Cri>80 500 mA LED  
CE F IP20 EAC

**MEMORIA S2**  
4,4W 640 Lm 3000K Cri>80 500 mA LED  
CE F IP20 EAC

**MEMORIA C1**  
4,4W 640 Lm 3000K Cri>80 500 mA LED  
CE F IP20 EAC

**MEMORIA C2**  
4,4W 640 Lm 3000K Cri>80 500 mA LED  
CE F IP20 EAC

ESEMPI DI COMPOSIZIONE/EXAMPLES OF COMPOSITION

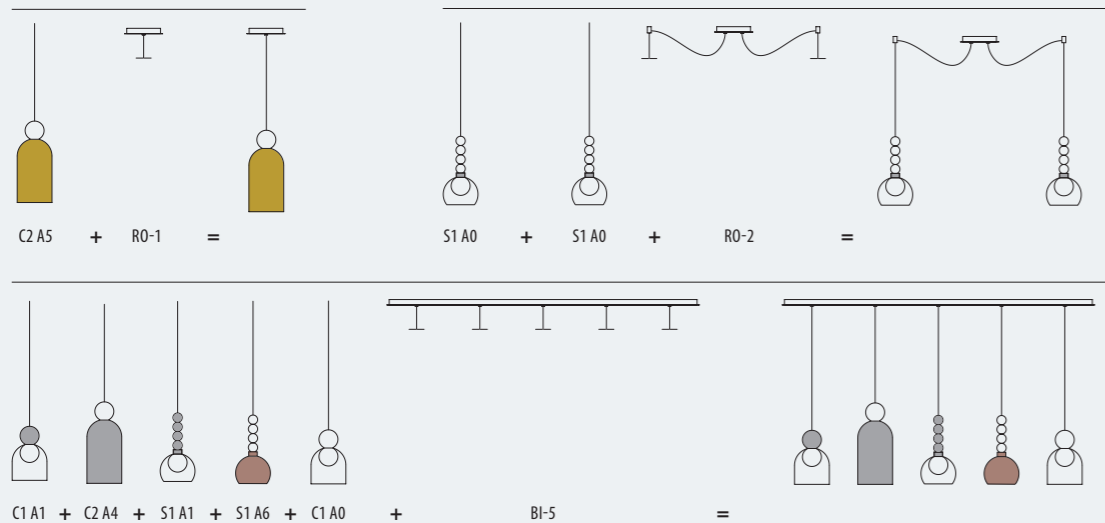

ROSONI/CANOPIES

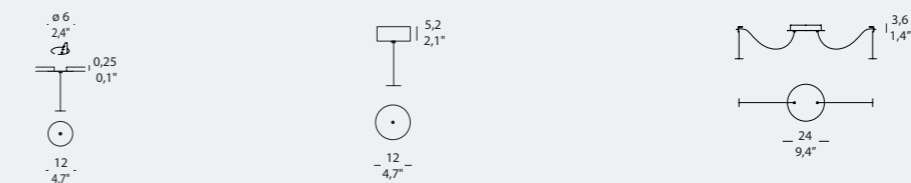

**MEMORIA IN-1**  
ROSONE A INCASSO A 1 LUCE  
CON DRIVER 220/240V  
1-LIGHT RECESSED CANOPY  
WITH DRIVER 220/240V  
CE F IP20 EAC

**MEMORIA RO-1**  
ROSONE A 1 LUCE CON DRIVER 220/240V  
1-LIGHT CANOPY WITH DRIVER 220/240V  
CE F IP20 EAC

**MEMORIA RO2**  
ROSONE A 2 LUCI CON DRIVER 220/240V  
2-LIGHT CANOPY WITH DRIVER 220/240V  
CE F IP20 EAC

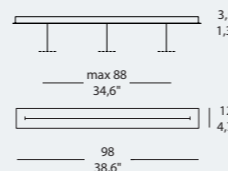

**MEMORIA BI-3**  
BINARIO A 3 LUCI CON DRIVER 220/240V  
3-LIGHT TRACK WITH DRIVER 220/240V

**MEMORIA BI-3 DIM PD**  
BINARIO A 3 LUCI CON DRIVER DIMMERABILE  
PUSH 220/240V  
3-LIGHT TRACK WITH PUSH DIMMABLE DRIVER  
220/240V  
CE F IP20 EAC

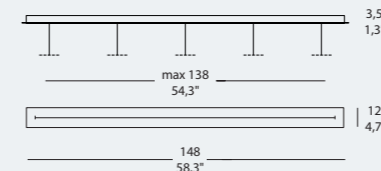

**MEMORIA BI-5**  
BINARIO A 5 LUCI CON DRIVER 220/240V  
5-LIGHT TRACK WITH DRIVER 220/240V

**MEMORIA BI-5 DIM PD**  
BINARIO A 5 LUCI CON DRIVER DIMMERABILE  
PUSH 220/240V  
5-LIGHT TRACK WITH PUSH DIMMABLE DRIVER  
220/240V  
CE F IP20 EAC

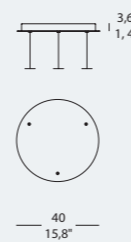

**MEMORIA RO3 C**  
ROSONE A 3 LUCI CON DRIVER 220/240V  
3-LIGHT CANOPY WITH DRIVER 220/240V

**MEMORIA RO3 C DIM PD**  
ROSONE A 3 LUCI CON DRIVER DIMMERABILE  
PUSH 220/240V  
3-LIGHT CANOPY WITH PUSH DIMMABLE  
DRIVER 220/240V  
CE F IP20 EAC

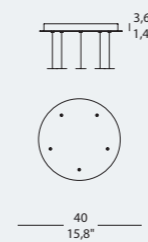

**MEMORIA RO5**  
ROSONE A 5 LUCI CON DRIVER 220/240V  
5-LIGHT CANOPY WITH DRIVER 220/240V

**MEMORIA RO5 DIM PD**  
ROSONE A 5 LUCI CON DRIVER DIMMERABILE  
PUSH 220/240V  
5-LIGHT CANOPY WITH PUSH DIMMABLE  
DRIVER 220/240V  
CE F IP20 EAC

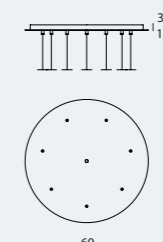

**MEMORIA RO7**  
ROSONE A 7 LUCI CON DRIVER 220/240V  
7-LIGHT CANOPY WITH DRIVER 220/240V

**MEMORIA RO7 DIM PD**  
ROSONE A 7 LUCI CON DRIVER DIMMERABILE  
PUSH 220/240V  
7-LIGHT CANOPY WITH PUSH DIMMABLE  
DRIVER 220/240V  
CE F IP20 EAC

SU RICHIESTA È POSSIBILE AVERE ANCHE DRIVER DIMMERABILE 1/10V  
1/10V DIMMABLE DRIVER CAN BE SUPPLIED BY REQUEST





# GADORA

design Romani Sacconi  
Architetti Associati

Spazio all'eleganza,  
ricercatezza in ogni dettaglio.

Ultimate style and refinement  
in every detail.





Gadora\_TE S1



Gadora\_S2L





Gadora\_TE S5



Gadora\_CO





Gadora\_SO9





Gadora\_S06



Gadora\_S4L



Gadora\_PA1 S



Gadora\_PA 1



## \_technical data

Gadora è un incontro tra eccellenze del Made in Italy.

Abbina la sapienza della lavorazione artistica di Murano al ricercato design di Evi Style. Gadora è un incontro tra più eleganze. Accosta il vetro soffiato "rigadin", mosso e scolpito in nervature parallele, a paralumi d'organza in raffinate colorazioni. Gadora è una collezione di lampade dall'armonia estetica unica, che riempie l'ambiente di esclusività ma nello stesso tempo lascia la possibilità di personalizzare lo spazio in funzione delle proprie esigenze di arredamento e di stile. La particolare caratteristica delle lampade a sospensione, infatti, permette oltre alle modalità riportate a catalogo, l'installazione con altezze differenti e la possibilità di creare delle composizioni con forme irregolari diversificando sempre la configurazione finale. Una soluzione assolutamente elegante.

Gadora is the fusion of Made in Italy excellences. The wisdom of the Murano artistic works and the sophisticated Evi Style design are combined. Gadora is a meeting between different kinds of elegance. It represents the juxtaposition of the wavy blown glass "rigadin", with parallel ribs, and organza lampshades in refined colors. The unique aesthetic harmony of the Gadora collection makes the environment exclusive but at the same time gives the possibility to customize the space, to meet your needs in style and furniture. In addition to the options shown in our catalogue, the distinctive feature of these suspension lamps is that you can customize the pendants at different heights or create compositions of variable shapes, offering thus enhanced flexibility in terms of configuration. A completely elegant solution.

Gadora ist ein Zusammentreffen der Spitzenelemente des Made in Italy. Es verbindet das Wissen der künstlerischen Murano-Bearbeitung mit dem ausgesuchten Design von Evi Style. Gadora ist das Zusammentreffen höherer Eleganz. Es verbindet das geblasene "Rigadin"-Glas, das in parallelen Rippen bewegt und eingemeißelt ist, mit Organza-Lampenschirmen in eleganten Farben. Gadora ist eine Lampenkollektion mit einer einzigartigen ästhetischen Harmonie, das die Umgebung mit Exklusivität füllt, aber gleichzeitig die Möglichkeit lässt, den Raum nach Wunsch und gemäß dem Einrichtungsstil individuell zu gestalten. Die besondere Eigenschaft dieser Hängelampen gestattet die Installation, außer den im Katalog angeführten Möglichkeiten, in verschiedenen Höhen und somit eine phantasiereiche Zusammensetzung mit stets neuen Konfigurationen. Eine absolut elegante Lösung.

Gadora est la rencontre des excellences du Made in Italy.

Elle associe le savoir du travail artistique de Murano au design raffiné d'Evi Style. Gadora est la rencontre de plusieurs élégances. Elle assortit le verre soufflé "rigadin", ondulé et sculpté en nervures parallèles, à des abat-jour en organza aux teintes raffinées. Gadora est une collection de lampes présentant une harmonie esthétique unique, qui remplit la pièce d'exclusivité tout en permettant de personnaliser l'espace en fonction des exigences personnelles de décoration et de style. La caractéristique des lampes à suspension permet, en effet, de réaliser les installations proposées dans le catalogue, mais aussi de les placer à des hauteurs différentes et de créer des compositions aux formes irrégulières diversifiant constamment la configuration finale. Une solution absolument élégante.

Gadora es un encuentro entre las excelencias del encuentro del Made in Italy. Combina la sabiduría del trabajo artístico de Murano con el rebuscado design de Evi Style. Gadora es un encuentro entre varias elegancias. Acerca el vidrio soplado "rigadin", movido y esculpido en nervios paralelos, a pantallas de organza en refinados colores. Gadora es una colección de lámparas de armonía estética única, que llena el ambiente de exclusividad pero al mismo tiempo deja la posibilidad de personalizar el espacio en función de las propias exigencias de decoración y de estilo. La peculiaridad estructural de las lámparas de suspensión permite, además de los modos previstos en el catálogo, la instalación con alturas diferentes creando además composiciones de formas irregulares, diversificando siempre la configuración final. Una solución absolutamente elegante.

Gadora – это встреча исключительностей Made in Italy.

Соединяет знание в области производства художественного муранского стекла и изысканный дизайн Evi Style. Gadora – это встреча элегантностей. Дутое стекло "rigadin", приведенное в движение и вылепленное в виде параллельных рифлений, соединено с абажурами из органзы изысканной цветовой гаммы. Gadora – коллекция светильников, характеризующая неповторимой эстетикой, наполняющая пространство эксклюзивностью, оставляя в то же время возможность для персонификации пространства, в зависимости от личных потребностей и стиля. Характерной деталью подвесных светильников, помимо модульности, указанной в каталоге, является возможность их установки на разной высоте и возможность создания композиций с оригинальными формами, дифференцируя конечную конфигурацию. Представляет собой абсолютно элегантное решение.

**Struttura:** metallo cromato.

**Vetro:** soffiato "rigadin".

**Diffusore:** paralumi in organza ignifuga classe 1 nei colori: avorio, bianco, bordeaux, grigio-cromo, e golden teak.

**Frame:** chromed metal.

**Glass:** blown "rigadin".

**Diffuser:** organza fireproof class 1 lampshades in these colors: ivory, white, burgundy, grey-chrome, and golden teak.

**Struktur:** Metall verchromt.

**Glas:** Geblasenes "Rigadin"-Glas.

**Diffusor:** Lampenschirme aus feuerfestem Organza, Klasse 1, in den Farben: Elfenbein, Weiß, Bordeaux, Grau-Chrom, und Golden Teak.

**Structure:** métal chrome.

**Verre:** soufflé "rigadin".

**Diffuseur:** abat-jour en organza ignifuga de la classe 1 dans les couleurs ivoire, blanc, bordeaux, gris-chrome, et golden teak.

**Estructura:** metal cromado.

**Vidrio:** soplado "rigadin".

**Diffusor:** pantallas en organza ignifugas clase 1 en los colores marfil, blanco, burdeos, gris-cromo, y golden teak.

**Структура:** хромированный металл.

**Стекло:** дутое стекло "rigadin".

**Рассеиватель:** абажуры из огнестойкой органзы класса 1 могут быть выполнены в следующих цветах: цвет слоновой кости, белый, бордовый, серый-хром и золотой тик.



**AV:** Avorio/Ivory



**BI:** Bianco/White



**CR:** Grigio-Cromo/  
Chrome-Grey



**GT:** Golden teak



**BX:** Bordeaux/Burgundy

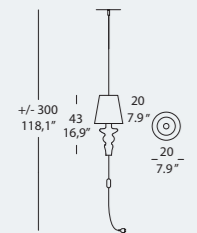

**GADORA TE S1**

1 x MAX 6,5W E14 LED

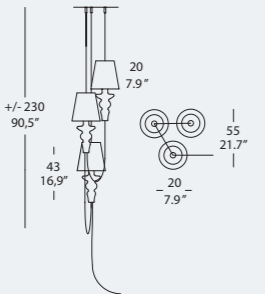

**GADORA TE S3**

3 x MAX 5W E14 LED DIM

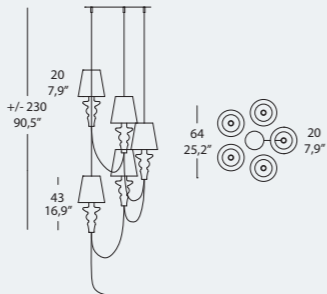

**GADORA TE S5**

5 x MAX 5W E14 LED DIM

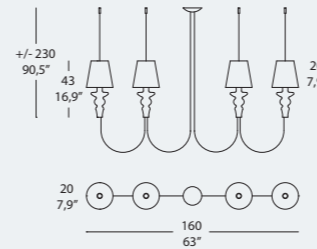

**GADORA S4L**

4 x MAX 6,5W E14 LED

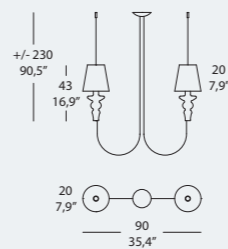

**GADORA S2L**

2 x MAX 6,5W E14 LED

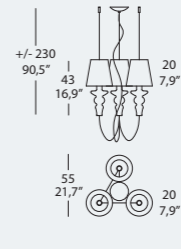

**GADORA SO 3**

3 x MAX 6,5W E14 LED

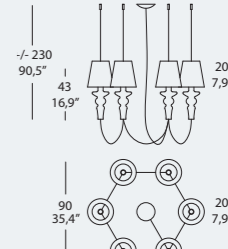
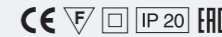

**GADORA SO 6**

6 x MAX 6,5W E14 LED

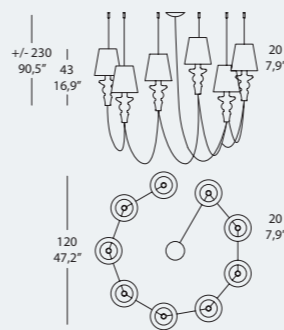

**GADORA SO 9**

9 x MAX 6,5W E14 LED

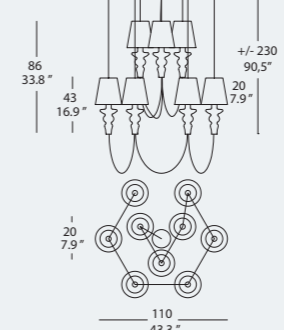

**GADORA SO 6+3**

9 x MAX 6,5W E14 LED

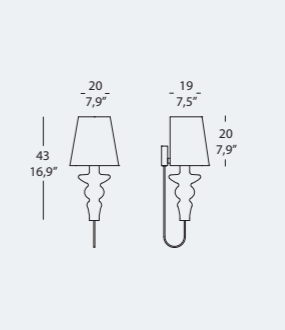

**GADORA PA 1**

1 x MAX 6,5W E14 LED

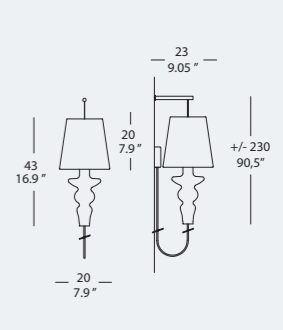

**GADORA PA1 M**

1 x MAX 6,5W E14 LED

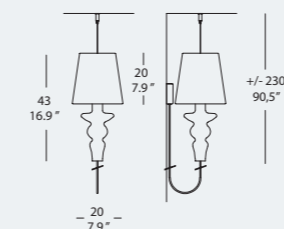

**GADORA PA1 S**

1 x MAX 6,5W E14 LED

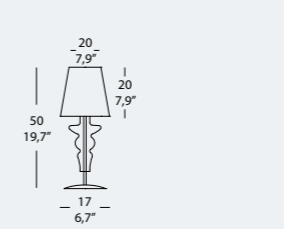

**GADORA CO**

1 x MAX 6,5W E14 LED

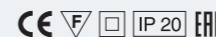



# GADORA CHIC

design\_Romani Sacconi  
Architetti Associati

Evoluzione di un classico  
di successo.

The evolution of a timeless  
classic.









Gadora Chic\_SO 6+3



Gadora Chic\_PA 1





Gadora Chic\_CO



Gadora Chic\_TE S3



Gadora Chic\_PA 1 S



Gadora Chic\_PA 1 M



# GADORA CHIC

Modello Europeo Registrato  
European Registered Design

## \_technical data

L'eleganza del vetro soffiato, la raffinatezza dei paralumi in organza, la preziosità delle finiture in bianco, cromo e oro 24 kt. Ogni dettaglio della collezione di lampade Gadora Chic parla di classe e di stile. Uno stile unico, immediatamente riconoscibile, ma nello stesso tempo personalizzabile in funzione dello spazio e delle scelte d'arredamento. La particolare caratteristica delle lampade a sospensione infatti, permette oltre alle modalità riportate a catalogo, l'installazione con altezze differenti e la possibilità di creare delle composizioni con forme irregolari, diversificando sempre la configurazione finale. Le potenzialità creative sono molteplici. Così come le probabilità di rimanere abbagliati dalla sua bellezza.

L'élégance du verre soufflé, le raffinement des abat-jour en organza, la préciosité des finitions blanc, chrome et or 24 carats. Chaque détail de la collection de lampes Gadora Chic parle de classe et de style. Un style unique, immédiatement reconnaissable, mais en même temps personnalisable en fonction de l'espace et des choix de décoration. La caractéristique des lampes à suspension permet, en effet, de réaliser les installations proposées dans le catalogue, mais aussi de les placer à des hauteurs différentes et de créer des compositions aux formes irrégulières diversifiant constamment la configuration finale. Les potentiels créatifs sont nombreux. Tout comme la probabilité d'être ébloui par sa beauté.

The elegance of blown glass, the refined organza lampshades, the precious finishes in white, chrome and gold 24 kt. Each detail of the Gadora Chic collection is an element of class and style. A unique and immediately recognizable style but at the same time customizable, according to the choices of space and furniture. In addition to the options shown in our catalogue, as a matter of fact, the distinctive feature of these suspension lamps is that you can customize the pendants at different heights or create compositions of variable shapes, thus offering enhanced flexibility in terms of configuration. There are lots of creative possibilities. As well as the chances of getting dazzled by her beauty.

La elegancia del vidrio soplado, la sofisticación de las pantallas en organza, la preciosidad de los acabados en blanco, cromo y oro 24 kt. Cada detalle de la colección de lámparas Gadora Chic habla de clase y de estilo. Un estilo único, inmediatamente reconocible, pero al mismo tiempo personalizable en función del espacio y de las elecciones de decoración. En efecto, las particulares características de las lámparas de suspensión permite además de los modos indicados en el catálogo, la instalación con alturas diferentes y la posibilidad de crear composiciones con formas irregulares, diversificando siempre la configuración final. Las potencialidades creativas son múltiples así como las probabilidades de quedar deslumbrados por su belleza.

Die Eleganz des geblasenen Glases, die Erlesenheit der Organza-Lampenschirme, der Wert der Verarbeitungen in Weiß, Chrom und 24 kt. Gold. Jedes Detail der Lampenkollektion Gadora Chic spricht von Klasse und Stil. Ein einzigartiger Stil, der sofort erkennbar ist, aber gleichzeitig je nach Raum und Einrichtungsstil individuell gestaltbar ist. Die besondere Eigenschaft dieser Hängelampen gestattet die Installation, zusätzlich zu der im Katalog angeführten Option, in verschiedenen Höhen und somit eine phantasiereiche Zusammensetzung mit stets neuen Konfigurationen. Die kreativen Möglichkeiten sind zahlreich. Wie auch die Wahrscheinlichkeit von ihrer Schönheit geblendet zu werden.

Элегантность дутого стекла, утонченность абажуров из органзы, изысканность белой, хромовой и золотой 24К отделок. Каждая деталь коллекции светильников Gadora Chic говорит о классе и стиле. Уникальный стиль, незамедлительно узнаваемый, оставляет в то же время возможность для персонализации пространства, в зависимости от личных потребностей и стиля. Характерной деталью подвесных светильников, помимо модульности, указанной в каталоге, является возможность их установки на разной высоте и возможность создания композиций с оригинальными формами, дифференцируя конечную конфигурацию. Заключает в себе многообразный творческий потенциал наряду с вероятностью потрясти своей красотой.

**Struttura:** metallo cromato o oro 24 kt.

**Frame:** chromed metal or gold 24 kt.

**Struktur:** Metall verchromt oder 24 kt. Gold.

**Structure:** métal chromé ou or 24 carats.

**Estructura:** metal cromado u oro 24 kt.

**Структура:** хромированный металл или золото 24К.

**Vetro:** soffiato nei colori: bianco, metallizzato cromo e metallizzato oro.

**Glass:** blown in the colors: white, metalized chrome and metalized gold.

**Glas:** Geblasen in den Farben Weiß, metallisches Chrom oder metallisiertes Gold.

**Verre:** souffler dans les couleurs: blanc, métallisé chrome et métallisé or.

**Vidrio:** soplado en los colores: blanco, metalizado cromo y metalizado oro.

**Стекло:** дутое стекло выполняется в следующих цветах: белое, металлизированный хром и металлизированное золото.

**Diffusore:** paralumi in organza ignifuga classe 1 nei colori: bianco, grigio-cromo e oro.

**Diffuser:** organza fireproof class 1 lampshades in the colors: white, grey-chrome and gold.

**Diffusor:** Lampenschirme aus feuerfestem Organza, Klasse 1, in den Farben: Weiß, Grau-Chrom und Gold.

**Diffuseur:** abat-jour en organza ignifuge de la classe 1 dans les couleurs blanc, gris-chrome et golden teak.

**Difusor:** pantallas en organza ignifuga clase 1 en los colores: blanco, gris-cromo y oro.

**Рассеиватель:** абажуры из огнестойкой органзы класса 1 могут быть выполнены в следующих цветах: белый, серый хром и золотой.



**BI:** Bianco/White

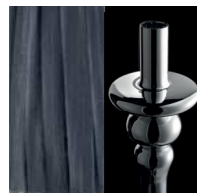

**CR:** Grigio-Cromo/Chrome-Grey



**OR:** Oro/Gold

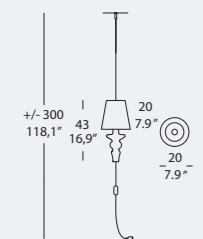

### GADORA CHIC TE S1

1 x MAX 6,5W E14 LED

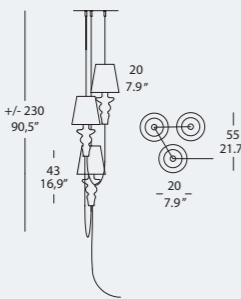

### GADORA CHIC TE S3

3 x MAX 5W E14 LED DIM

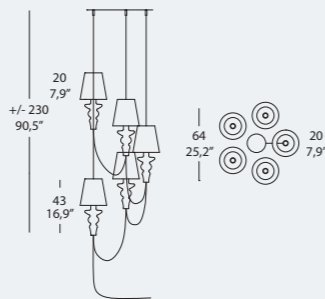

### GADORA CHIC TE S5

5 x MAX 5W E14 LED DIM

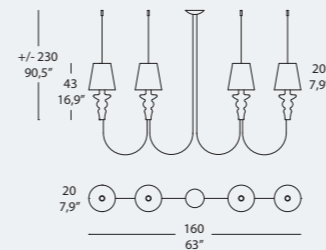

### GADORA CHIC S4L

4 x MAX 6,5W E14 LED

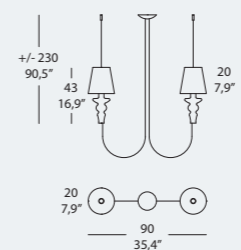

### GADORA CHIC S2L

2 x MAX 6,5W E14 LED

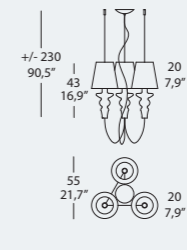

### GADORA CHIC SO 3

3 x MAX 6,5W E14 LED

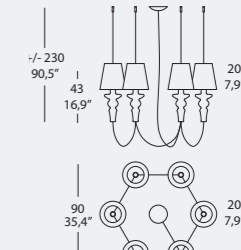

### GADORA CHIC SO 6

6 x MAX 6,5W E14 LED

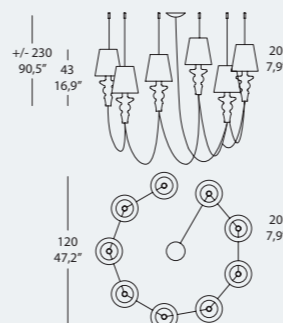

### GADORA CHIC SO 9

9 x MAX 6,5W E14 LED

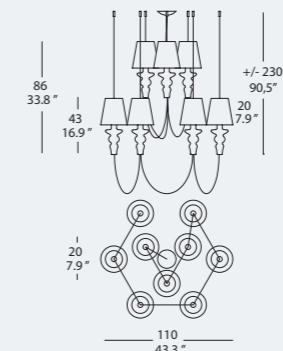
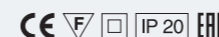

### GADORA CHIC SO 6+3

9 x MAX 6,5W E14 LED

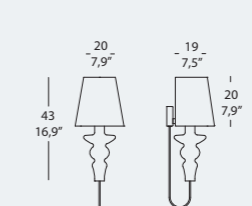
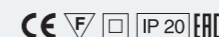

### GADORA CHIC PA 1

1 x MAX 6,5W E14 LED

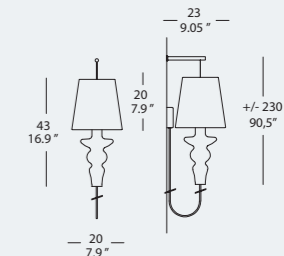
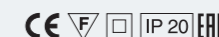

### GADORA CHIC PA 1 M

1 x MAX 6,5W E14 LED

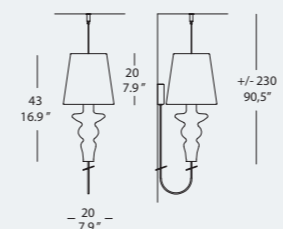

### GADORA CHIC PA 1 S

1 x MAX 6,5W E14 LED

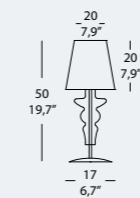

### GADORA CHIC CO

1 x MAX 6,5W E14 LED

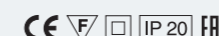





# SAN MARCO

design\_Romani Sacconi  
Architetti Associati

L'anima di Venezia  
che illumina i nostri tempi.

The soul of Venice  
illuminates our time.





San Marco\_SO 7





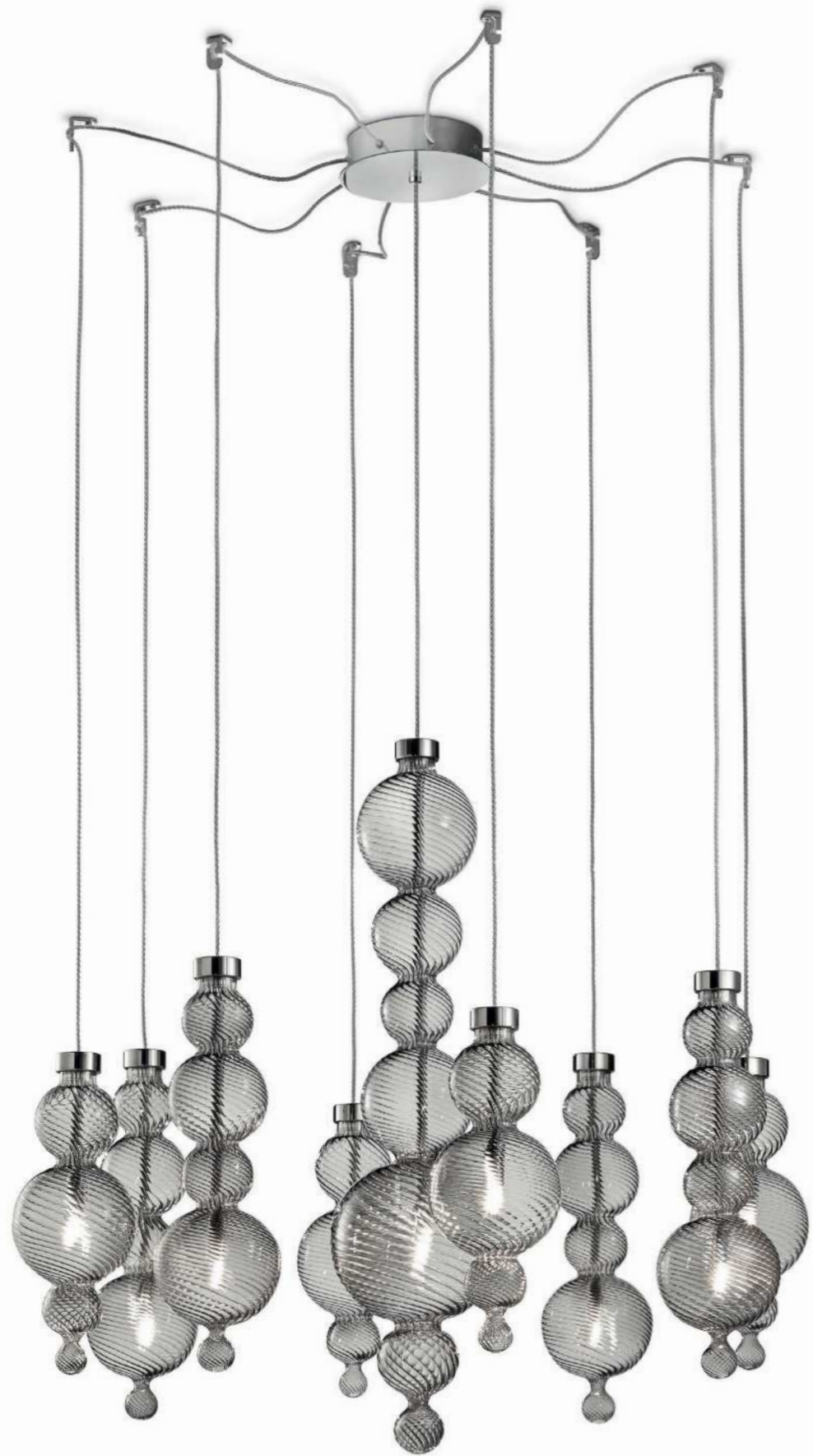

San Marco\_SO 9



San Marco\_SO 9B





San Marco\_PA 1



San Marco\_SO 13B









San Marco\_SO 3



San Marco\_ esempio di composizione / example of composition





San Marco\_S07 versione personalizzata / custom version



# SAN MARCO

## \_technical data

Un omaggio a Venezia, alla sua bellezza e alla sua arte vetraria. La collezione di lampade San Marco è una riedizione del classico chandelier Veneziano, qui destrutturato e solo riecheggiato dall'accostamento di semplici globi vetri di diverso diametro, irrigiditi in successioni modulari con caratteristica goccia pendente. Sono proprio queste concatenazioni lineari a rimandare all'omonima piazza SAN MARCO e alle tondeggianti forme tracciate nello sky-line dalle cupole e dalla facciata della Basilica. La definizione dei 3 modelli base in vetro soffiato "torcion", ciascuno dotato di un proprio punto luce e di una propria sequenza-estensione, permette di allestire infinite composizioni multiple, per un prodotto contemporaneo e di facile personalizzazione.

Un hommage à Venise, à sa beauté et à son art verrier. La collection de lampes San Marco est une réédition du chandelier classique Vénitien, déstructuré ici et évoqué par l'assortiment de simples boules en verre de différents diamètres, raidis en successions modulaires avec le pendentif caractéristique en forme de goutte. Ce sont justement ces enchaînements linéaires qui renvoient à la place SAINT-MARC du même nom et aux formes arrondies tracées dans le sky-line par les coupoles et la façade de la Basilique. La définition des 3 modèles de base en verre soufflé "torcion", muni chacun d'un point lumineux propre et d'une propre séquence-extension, permet d'aménager d'infinies compositions multiples, pour un produit contemporain et facile à personnaliser.

An homage to Venice, to its beauty and the glass-making. The San Marco collection of lamps is a de-structured restyle of the classic Venetian chandelier where simple glass globes of various sizes are matched with a modular arrangement of glass pendants and features of the facade of SAINT MARK'S basilica and the square of the same name. The 3 basic models in "torcion" blown glass - each equipped with own bulb and sequence-extension - are easy to customize with an infinite variety of arrangements that let you create your personal contemporary style.

Un homenaje a Venecia, a su belleza y a su arte del vidrio. La colección de lámparas San Marco es una reelaboración de la clásica araña veneciana, que se ha desestructurado para volver a surgir mediante la combinación de simples bolas de cristal de diferentes diámetros, combinadas en sucesiones de módulos con una característica gota colgante. Son exactamente estas concatenaciones lineales las que evocan la homónima plaza SAN MARCO y las formas redondeadas trazadas en la silueta por las cúpulas y fachadas de la Basilica. La definición de los tres modelos básicos de vidrio soplado "torcion", cada uno dotado con un punto de luz y con su secuencia-extension, permite realizar infinitas composiciones múltiples, para un producto contemporáneo y de fácil personalización.

Ein Tribut an die Stadt Venedig, ihre Schönheit und ihre Glaskunst. Die Lampenkollektion San Marco ist eine Neuauflage des klassischen venezianischen Kerzenständers, frei strukturiert und in Anordnung einfacher Glaskugeln verschiedener Durchmesser, die hängend als Tropfen angebracht sind. Genau diese Verkettungen sind es, die an den gleichnamigen Platz SAN MARCO und an die rundlichen Formen der Kuppeln und der Fassade der Basilika erinnern. Die Definition der 3 Basismodelle aus geblasenem "Torcion"-Glas, jedes mit einer eigenen Lichtquelle und Sequenz ausgestattet, ermöglicht unzählige und vielfältige Zusammensetzungen für ein modernes und leicht personalisierbares Produkt.

Подарок Венеции, ее красоте и ее стеклудвному искусству. Коллекция светильников San Marco - это переиздание классического Венецианского канделябра, здесь децентрированного и вновь созданного сочетанием простых стеклянных шаров различных диаметров, застывших в модульной последовательности с характеристикой падающей капли. Именно эти линейные сцепления напоминают об одноименной площади SAN MARCO и об округлых формах, чертящих в небе силуэты куполов и фасада Базилики. Представлена тремя базовыми модулями из дутого стекла "torcion", каждый из которых оснащен своим источником света и имеет возможность расширения последовательности, что позволяет создавать бесконечное число композиций с использованием современного и легко персонализированного продукта.

**Struttura:** metallo cromato. **Frame:** chromed metal. **Struktur:** Metall verchromt. **Structure:** métal chrome. **Estructura:** metal cromado. **Структура:** хромированный металл.

**Diffusore:** vetro soffiato nei colori: ambra, cristallo trasparente e fumé. **Diffuser:** blown glass in these colors: amber, transparent crystal and smoke grey. **Diffusor:** Geblasenes Glas in den Farben: Bernstein, Kristall transparent und rauchgrau. **Difusor:** vidrio soplado en los colores: ámbar, cristal transparente y ahumado. **Рассеиватель:** дутое стекло выполнено в следующих оттенках: янтарь, прозрачный хрусталь и дымчатый.

<p><b>SAN MARCO SO 13A</b> 13 x MAX 4,8W G9 LED  CE F IP 20 EAC</p>	<p><b>SAN MARCO SO 13B</b> 13 x MAX 4,8W G9 LED  CE F IP 20 EAC</p>	<p><b>SAN MARCO SO 9</b> 9 x MAX 4,8W G9 LED  CE F IP 20 EAC</p>	<p><b>SAN MARCO SO 7</b> 7 x MAX 4,8W G9 LED  CE F IP 20 EAC</p>
---	---	--	--

<p><b>SAN MARCO SO 3</b> 3 x MAX 4,8W G9 LED  CE F IP 20 EAC</p>	<p><b>SAN MARCO SO 9B</b> 9 x MAX 4,8W G9 LED  CE F IP 20 EAC</p>	<p><b>SAN MARCO SO 5B</b> 5 x MAX 4,8W G9 LED  CE F IP 20 EAC</p>	
<p><b>SAN MARCO PA 1</b> 1 x MAX 4,8W G9 LED  CE F IP 20 EAC</p>	<p><b>SAN MARCO SO1G S/R</b> 1 x MAX 4,8W G9 LED  CE F IP 20 EAC</p>	<p><b>SAN MARCO SO1M S/R</b> 1 x MAX 4,8W G9 LED  CE F IP 20 EAC</p>	<p><b>SAN MARCO SO1P S/R</b> 1 x MAX 4,8W G9 LED  CE F IP 20 EAC</p>
<p><b>SAN MARCO CO</b> 1 x MAX 4,8W G9 LED  CE F IP 20 EAC</p>	<p><b>SAN MARCO SO 1G</b> 1 x MAX 4,8W G9 LED  CE F IP 20 EAC</p>	<p><b>SAN MARCO SO 1M</b> 1 x MAX 4,8W G9 LED  CE F IP 20 EAC</p>	<p><b>SAN MARCO SO 1P</b> 1 x MAX 4,8W G9 LED  CE F IP 20 EAC</p>

# LEGENDA



Tutte le lampade sono costruite secondo le norme europee EN 60598-1 e con materiali approvati da vari istituti di sicurezza.  
All the lamps are made according to European standards EN 60598-1 and of materials approved by various safety institutes.



Apparecchio predisposto per il montaggio su superfici infiammabili.  
Fixture ready for mounting on inflammable superfaces.



Apparecchio in classe II - Apparecchio nel quale la protezione contro la scossa elettrica non si basa unicamente sull'isolamento fondamentale, ma anche sulle misure supplementari di sicurezza costituite dal doppio isolamento o dall'isolamento rinforzato. Queste misure non comportano dispositivi per la messa a terra e non dipendono dalle condizioni d'installazione.

Class II appliance - appliance in which protection against electric shock is not only based on basic insulation, but also on additional safety measures, i.e. double insulation or reinforced insulation. These measures do not involve earthing devices and do not depend on the installation conditions.

Grado di protezione - Stabilisce un sistema per la classificazione degli apparecchi elettrici in base al grado di protezione fornito dagli involucri degli stessi.



I simboli utilizzati per indicare questo grado di protezione sono costituiti dalle lettere "IP" seguite da due cifre caratteristiche:







- la prima cifra indica la protezione contro la penetrazione dei corpi solidi e della polvere;
- la seconda cifra indica la protezione contro la penetrazione dei liquidi.

Protection level - This establishes a classification system for electric appliances based on the protection level supplied by their casing.

The symbols used to indicate the level of protection are the two letters, "IP" followed by two figures.

- The first figure indicates the protection against penetration by solid bodies and dust;
- The second figure indicates the protection against penetration by liquids.

## Gradi di protezione IP - Protection degrees (IP)

1ª cifra protezione alla penetrazione di corpi solidi. 1st figure: protection against penetration by solid bodies.		2ª cifra protezione contro la penetrazione d'acqua. 2nd figure: protection against penetration by water.	
0	Non Protetto. No protection.	0	Non Protetto. No protection.
1	Protetto da corpi solidi superiori a 50 mm. Protected against solid matters (over 50 mm.).	1	Protetto contro lo stillicidio. Protected proof fixture. 
2	Protetto da corpi solidi superiori a 12 mm. Protected against solid matters (over 12 mm.).	2	Protetto da cadute d'acqua, inclinazione di 15°. Protected against water falling at 15° angle.
3	Protetto da corpi solidi superiori a 2,5 mm. Protected against solid matters (over 2,5 mm.).	3	Protetto contro la pioggia. Rain proof fixture. 
4	Protetto da corpi solidi superiori a 1 mm. Protected against solid matters (over 1 mm.).	4	Protetto contro gli spruzzi. Splash proof fixture. 
5	Protetto contro la polvere. Dust proof. 	5	Protetto contro getti d'acqua. Water jet proof. 
6	Totalmente protetto contro la polvere. Fully dust. 	6	Protetto contro le ondate. Wave proof.



Articoli con moduli LED: consumo ridotto, lunga durata.  
Articles with LED modules: low consumption, long life.



Articoli con moduli LED Dim to Warm: consumo ridotto, lunga durata.  
Articles with Dim to Warm LED modules: low consumption, long life.



Dimmerabile Triac.  
Triac dimmable.



Dimmerabile.  
Dimmable.



Certificazione di conformità valida per l'unione doganale EurAsEC.  
Certification for Eurasian Customs Union.



Associato/Associate



Morosini  
North America branch



1971 NE 148 ST.  
NORTH MIAMI  
FL 33141  
t. 305.919.0286 f. 305.394.8739

[www.medialightusa.com](http://www.medialightusa.com)  
[info@medialightusa.com](mailto:info@medialightusa.com)



MOROSINI

Marcon - Venezia

t. +39 041 5952772 +39 0415951544

info@morosini.lighting

www.morosini.lighting

