

2017  
—  
2018



PRANDINA













# PRANDINA

Dal 1982 Prandina è un marchio italiano di design dell'illuminazione, con una filosofia creativa risponde a pochi criteri essenziali: semplicità e rigore formale, funzionalità e qualità durevole. Prandina rispecchia questi valori forti, comunicando un'identità definita e riconoscibile, al di fuori di convenzioni stilistiche, mode e tendenze di breve periodo.

Lungo la sua trentennale attività, Prandina ha costantemente esplorato le potenzialità del vetro, ricercando nuove forme per interpretare, in chiave contemporanea, un materiale che per tradizione è quello eletto dalla luce, dall'uomo e dall'ambiente.

Forte di questa esperienza, Prandina persegue idee e forme congeniali alla propria filosofia, anche con tecniche e materiali innovativi, cercando di definire prodotti sobri, versatili e riconoscibili.

Grazie a questa mediazione tra tradizione e innovazione, la collezione Prandina può oggi interpretare adeguatamente gli spazi dell'abitare e del contract (architettuale), con prodotti che possono essere inseriti in progetti già definiti o sulla base di specifiche richieste.

—

*Prandina is an Italian brand who started in the interior lighting design in 1982.*

*Its creative philosophy fulfils several criteria: simplicity and formal precision, functionality and long-lasting quality.*

*Prandina reflects these strong values communicating a defined and recognizable identity, breaking with current styles, fads and short-term trends.*

*Throughout its thirty years of activity, Prandina has always explored the potentialities of glass, looking for new shapes to interpret, in a contemporary way, a material that has traditionally been elected by the light, the man and the environment.*

*According to this experience, Prandina pursues ideas and shapes fitting its philosophy, also with innovative techniques and materials, aiming to define simple, versatile and recognisable products.*

*Thanks to this mediation between tradition and innovation, today Prandina's collection can properly interpret both residential and contract spaces, with products that can be integrated into already defined projects or adapted to satisfy specific requests.*









Collection

—

**ABC**

Sandro Santantonio Design - 2004

---



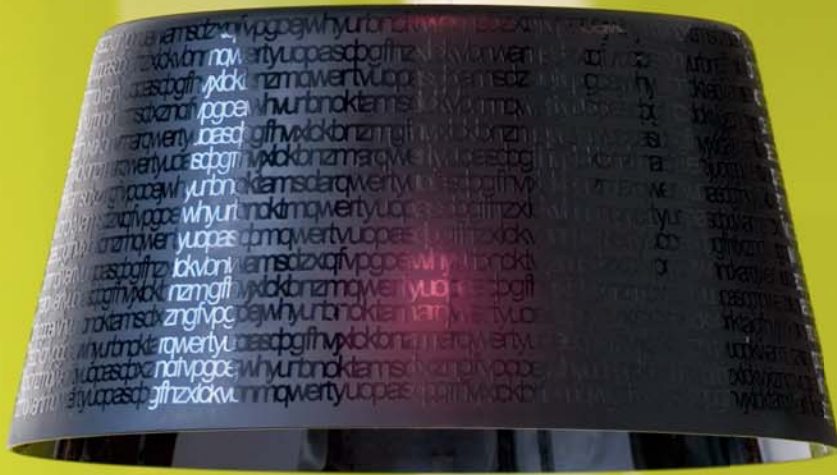

Collection

—

# ARGENTUM

Theodor Neumaier - 2004



Technical page: P.296 - P.297

**ARGENTUM W4**

Collection

—

**BILUNA**

Luc Rameel - 2007





**BILUNA S7** Technical page: P.148 - P.149











Collection

—

# **BLOOM**

Prandina R&D - 2012

---





Technical page: P.150 - P.151

**BLOOM S5**



Collection

—

**CHAN**

Prandina R&D - 2016

---









Collection

—

# CHORUS

Azzolin/Prandina R&D - 2012



Technical page: P.160 - P.161

**CHORUS S5**



Collection

—

**CPL**

Christian Ploderer - 1998



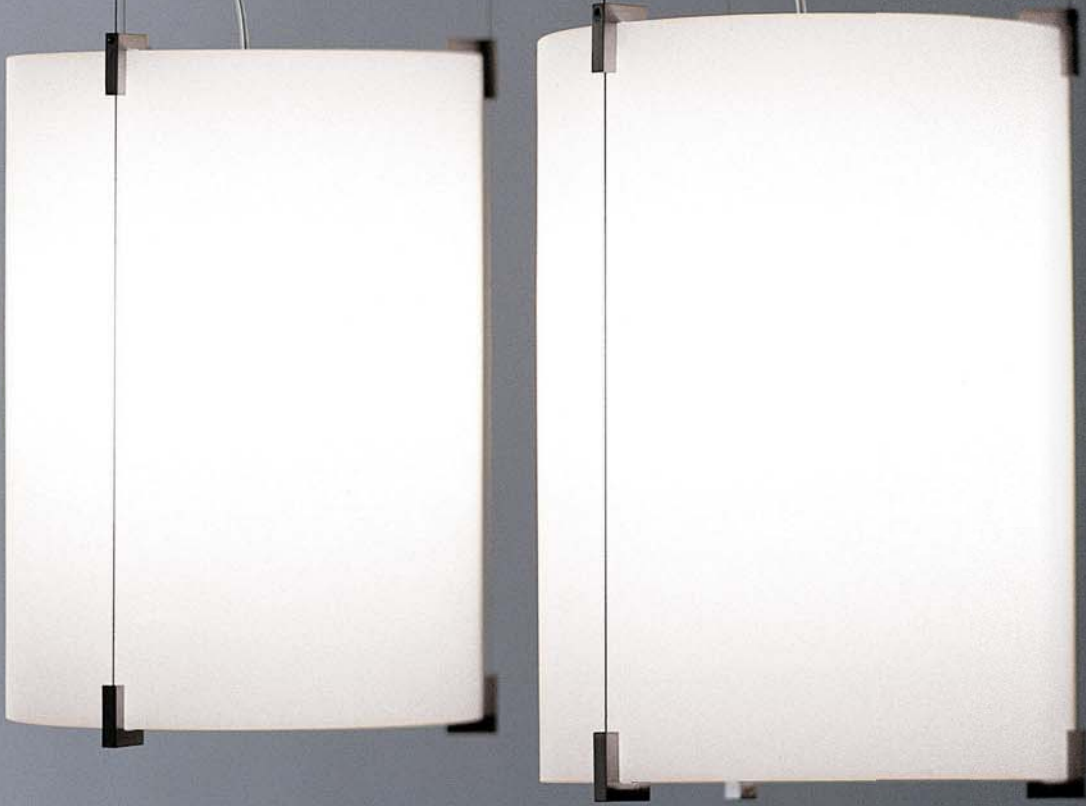

**CPL S7** Technical page: P.164 - P.165







**CPL F7** Technical page: P.270 - P.271



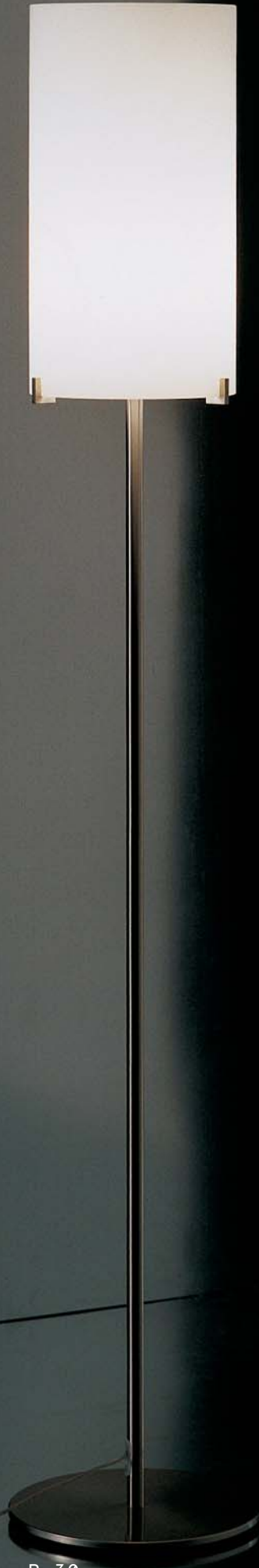



Collection

—

**ELLE**

Jannis Ellenberger - 2013



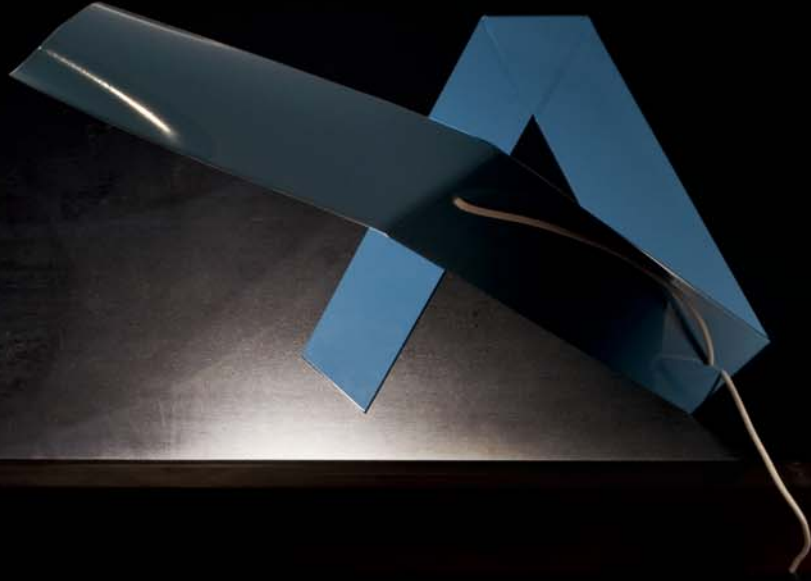

ELLE T1 Technical page: P.242 - P.243









Technical page: P.242 - P.243

**ELLE T1**



Collection



# EFFIMERA

Prandina R&D - 2016

---



Technical page: P.274 - P.275

**EFFIMERA F50**





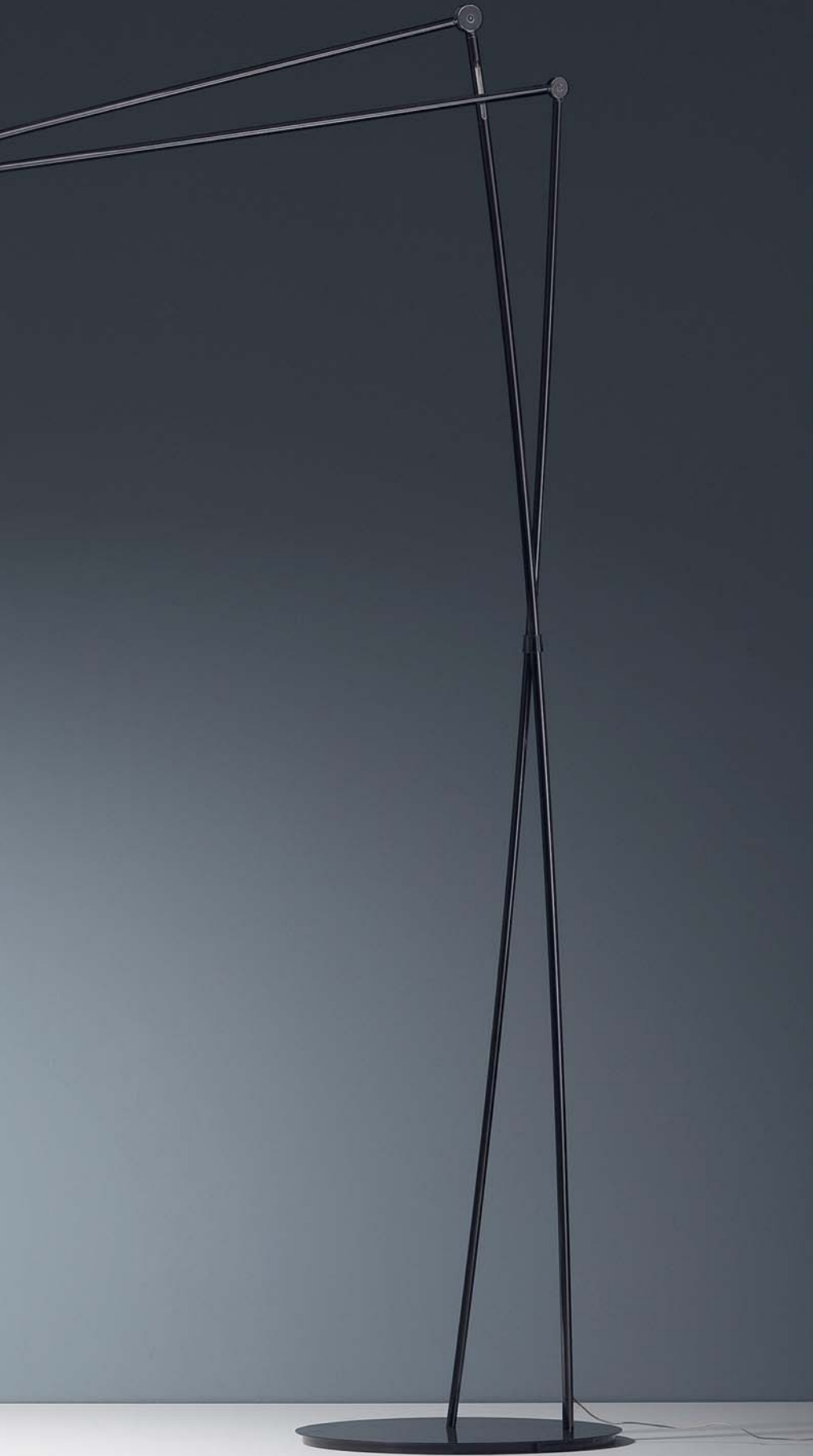

Collection

—

# EQUILIBRE

Luc Rameel - 2007





Technical page: P.278 - P.279

**EQUILIBRE F33**



# EQUILIBRE S33







Collection

—

**EXTRA**

Mengotti / Prandina - 1994



Collection

—

# FINLAND

Mengotti / Prandina - 2003







Collection

—

**GIFT**

DINN! design - 2016



Technical page: P.244 - P.245

**GIFT T1**







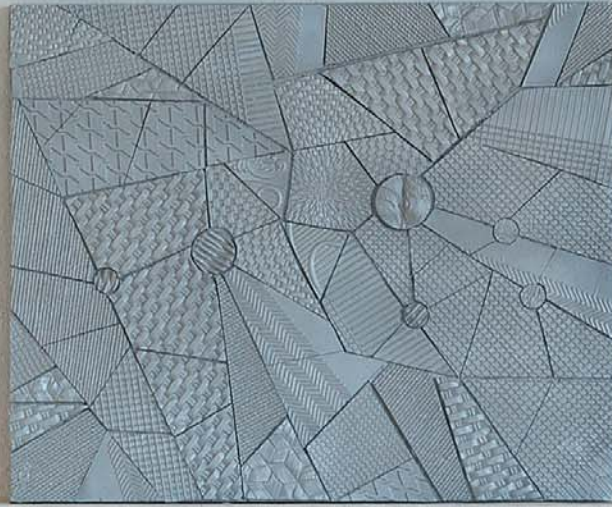

Collection

—

# GINGER

Azzolin / Prandina R&D - 2009





Technical page: P.172 - P.173

**GINGER S50**



# GINGER F50







Collection

—

**GLAM**

Luc Rameel - 2005





Technical page: P.250 - P.251

**GLAM T3**





Collection

—

**GONG**

Prandina R&D - 2012

---





Technical page: P.174 - P.175

# GONG MINI LED 5R







**GONG S3** Technical page: P.178 - P.179











Technical page: P.252 - P.253

**GONG T1.T3**





Collection

—

# GURU

P. Kristian Pettersen - 2009



**GURU S3** Technical page: P.180 - P.181



Collection

—

**LA BELLE**

Filippo Protasoni - 2011





Collection

—

# LANDING

Prandina R&D - 2017

---





## LANDING S3

Technical page: P.186 - P.187

[www.prandina.it](http://www.prandina.it)





Technical page: P.188 - P.189

**LANDING S50**





# LANDING S55





Technical page: P.190 - P.191

**LANDING S70**



**LANDING GLASS S70**





Technical page: P.254 - P.255

**LANDING T3**





Collection



# LED MACHINE

Prandina R&D - 2017

---



Technical page: P.194 - P.195

**LED MACHINE S3**



Technical page: P.196 - P.197

# LED MACHINE S30





Technical page: P.286- P.287

**LED MACHINE F3**





Collection

—

**LEMBO**

P. Kristian Pettersen - 2010



Collection



# LIGHT VOLUMES

Bakerygroup - 2000



Technical page: P.198 - P.199

**LIGHT VOLUMES 34S**





Collection

—

**LIN**

Mengotti / Prandina - 1992

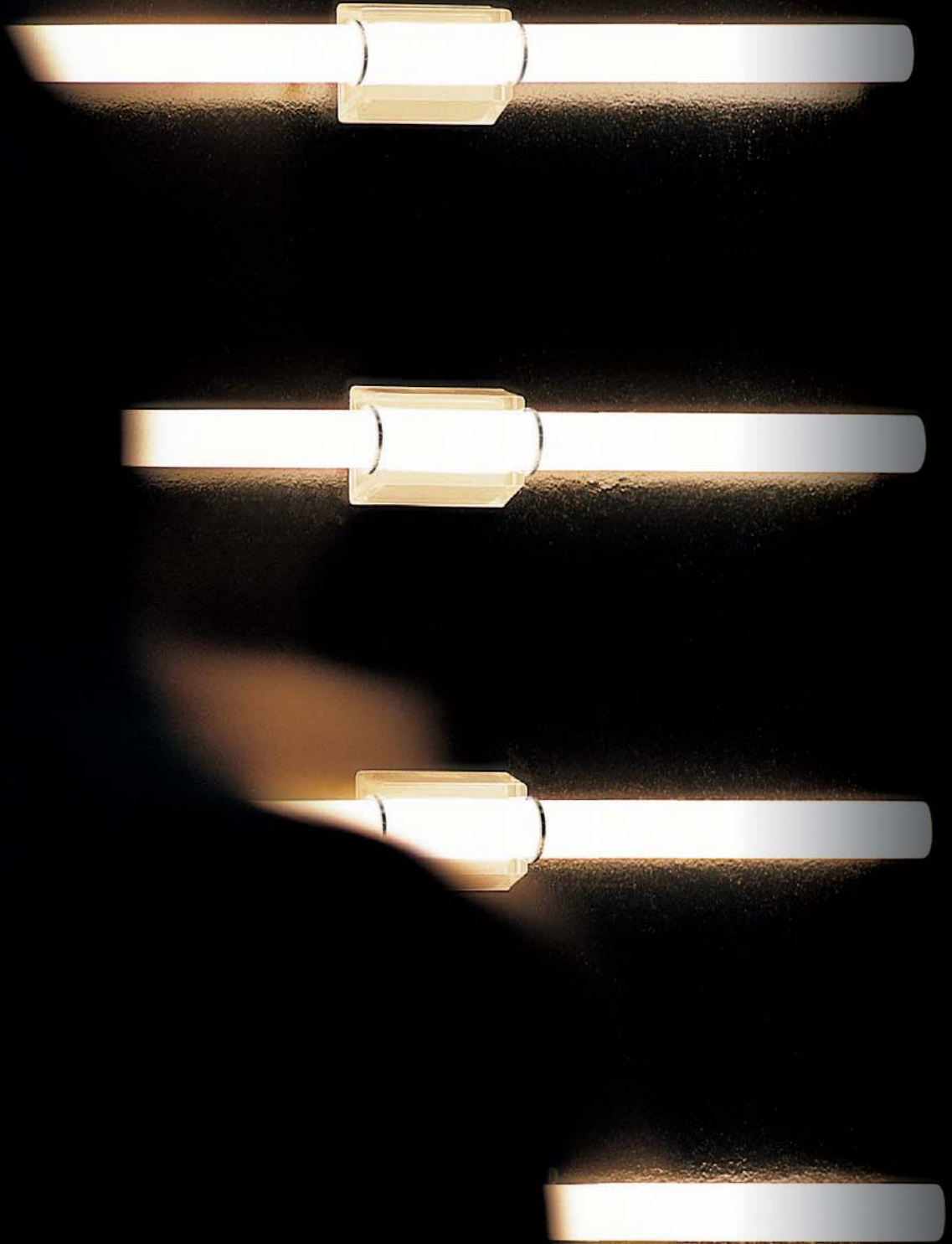

Technical page: P.306 - P.307

**LIN W1**

Collection



# MARLENE

Prandina R&D - 2010

---





**MARLENE S3** Technical page: P.200 - P.201





Collection

—

**MICO**

Prandina R&D - 2015

---



Technical page: P.256 - P.257

**MICO T3**



Collection

—

**MINT**

Azzolin / Prandina R&D - 2011













Collection

—

**MOOD**

Mengotti / Prandina - 2002

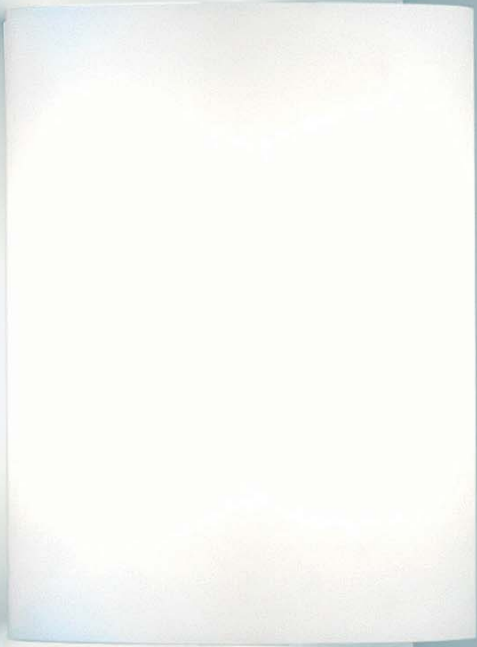



Collection

—

# NOTTE

Mengotti / Prandina - 2004















Collection

—

**OVER**

Mengotti / Prandina - 2003





Technical page: P.210 - P.211

**OVER S5**





Collection

—

# PARAPH

Serge and Robert Cornelissen - 2011







Technical page: P.258 - P.259

**PARAPH T3**





Collection

—

# PLATONE

Filippo Protasoni - 2009







Collection

—

**ROOM**

Hettler / Tüllmann - 2009





Collection



# SANTACHIARA

Prandina R&D - 2016

---



Collection



# SEGESTA

Prandina R&D - 2017

---













Collection

—

**SERA**

Mengotti / Prandina - 2000





Technical page: P.216 - P.217

**SERA SMALL S1**



**SERA T1** Technical page: P.260 - P.261







Technical page: P.292 - P.293

**SERA F1**





Collection

—

**TECA**

Azzolin / Prandina R&D - 2005



Technical page: P.314 - P.315

**TECA W3**









Collection

—

# TEODORA

Prandina R&D - 2015

---



Technical page: P.220 - P.221

**TEODORA S1.S3.S5**









Technical page: P.222 - P.223

**TEODORA GLASS S3**



Collection

—

**TIARA**

Prandina R&D - 2012

---





Technical page: P.224 - P.225

**TIARA S5**



Collection



# VESTALE

Prandina R&D - 2016

---













Technical page: P.226 - P.227

**VESTALE S3**



Collection

—

**ZERO**

Mengotti / Prandina - 1994





Technical page: P.230 - P.231

**ZERO S7**



Collection



# ZERODIECI

Prandina R&D - 2010

---

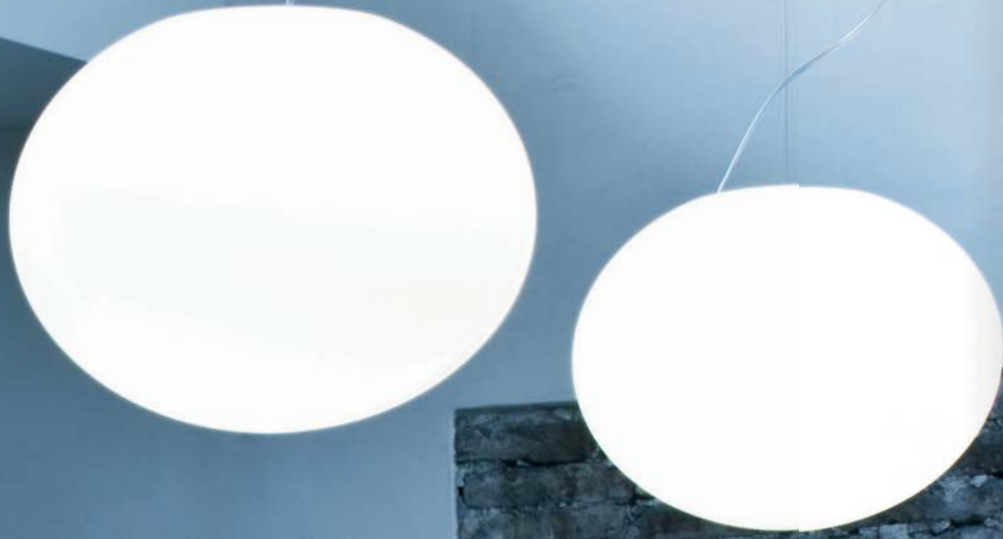

Technical page: P.232 - P.233

**ZERODIECI S5**







# TECHNICAL INDEX

—



**ABC S1.S3.S5** [P.146-P.147](#)  
**BILUNA S5.S7** [P.148-P.149](#)  
**BLOOM S5** [P.150-P.151](#)  
**CHAN 6.9** [P.152-P.157](#)  
**CHORUS MINI S** [P.158-P.159](#)  
**CHORUS S5** [P.160-P.161](#)  
**CPL S1** [P.162-P.163](#)  
**CPL S7** [P.164-P.165](#)  
**EQUILIBRE S3** [P.166-P.167](#)  
**EQUILIBRE S33** [P.168-P.169](#)  
**EXTRA S1.S3** [P.170-P.171](#)  
**GINGER S30.S50** [P.172-P.173](#)  
**GONG MINI S** [P.174-P.175](#)  
**GONG S1** [P.176-P.177](#)  
**GONG S3.S5** [P.178-P.179](#)  
**GURU S3** [P.180-P.181](#)  
**LA BELLE S5** [P.182-P.183](#)  
**LANDING S** [P.184-P.193](#)  
**LED MACHINE S3.S30** [P.194-P.197](#)  
**LIGHT VOLUMES 33S.34S.34S6** [P.198-P.199](#)  
**MARLENE S1.S3.SMALL S1** [P.200-P.201](#)  
**NOTTE S1.S3** [P.202-P.203](#)  
**NOTTE METAL S1.S3** [P.204-P.205](#)  
**NOTTE S5.S7** [P.206-P.207](#)  
**NOTTE METAL S5.S7** [P.208-P.209](#)  
**OVER S3.S5** [P.210-P.211](#)  
**SANTACHIARA S1.S3.S5** [P.212-P.213](#)  
**SEGESTA S3.S5** [P.214-P.215](#)  
**SERA S1.SMALL S1** [P.216-P.217](#)  
**TECA S1.S3.S5.S7** [P.218-P.219](#)  
**TEODORA S1.S3.S5** [P.220-P.221](#)  
**TEODORA GLASS S1.S3** [P.222-P.223](#)  
**TIARA S5** [P.224-P.225](#)  
**VESTALE S3** [P.226-P.227](#)  
**ZERO S1G9** [P.228-P.229](#)  
**ZERO S3.S5.S7** [P.230-P.231](#)  
**ZERODIECI S5.S7** [P.232-P.233](#)



**ABC T1.T3** [P.23 6-P.237](#)  
**CPL T1.T3.SMALL T1** [P.238-P.239](#)  
**CPL T30** [P.240-P.241](#)  
**ELLE T1** [P.242-P.243](#)  
**GIFT T1.T10** [P.244-P.245](#)  
**GINGER T30.T50** [P.246-P.247](#)  
**GLAM SMALL T1.T3** [P.248-P.249](#)  
**GLAM T1.T3** [P.250-P.251](#)  
**GONG T1.T3** [P.252-P.253](#)  
**LANDING T3** [P.254-P.255](#)  
**MICO T1.T3** [P.256-P.257](#)  
**PARAPH T3** [P.258-P.259](#)  
**SERA T1.SMALL T1** [P.260-P.261](#)  
**VESTALE T3** [P.262-P.263](#)



**ABC F3.F5** [P.266-P.267](#)  
**BILUNA F5.F7** [P.268-P.269](#)  
**CPL F1.F7** [P.270-P.271](#)  
**EFFIMERA F5** [P.272-P.273](#)  
**EFFIMERA F50** [P.274-P.275](#)  
**EQUILIBRE F3** [P.276-P.277](#)  
**EQUILIBRE F33** [P.278-P.279](#)  
**EQUILIBRE F33 DOWNLIGHT** [P.280-P.281](#)  
**GIFT F10** [P.282-P.283](#)  
**GINGER F30.F50** [P.284-P.285](#)  
**LED MACHINE F3** [P.286-P.287](#)  
**PARAPH F3** [P.288-P.289](#)  
**ROOM F50.F55** [P.290-P.291](#)  
**SERA F1** [P.292-P.293](#)



**ARGENTUM W3.W4.W7** [P.296-P.297](#)  
**CPL MINI W1.W3.W5** [P.298-P.299](#)  
**LEMBO W1.W3** [P.300-P.301](#)  
**LEMBO WW1.WW3** [P.302-P.303](#)  
**LIGHT VOLUMES 21W.22W.23W** [P.304-P.305](#)  
**LIN W1** [P.306-P.307](#)  
**MINT W3.W4.W5** [P.308-P.309](#)  
**MOOD W3.SMALL W3** [P.310-P.311](#)  
**PLATONE W1.W3** [P.312-P.313](#)  
**TECA W1.W3.W5.W7** [P.314-P.315](#)



**ARGENTUM W3.W4.W7** [P.318-P.319](#)  
**EQUILIBRE C3** [P.320-P.321](#)  
**EQUILIBRE C33** [P.322-P.323](#)  
**FINLAND C1.C3** [P.324-P.325](#)  
**LIGHT VOLUMES ECO 21C.22C.23C** [P.326-P.327](#)  
**MINT W3.W4.W5** [P.328-P.329](#)

## MARKS & SYMBOLS

 conformità europea / European conformity

 indice di protezione / protection level

650° prova filo incandescente / glow wire test

 standards for accesible design

 eElectrical testing laboratories approval

 idoneo per il montaggio su superfici normalmente infiammabili / suitable for mounting on normally inflammable surfaces

 classe 1 / isolamento semplice: è richiesta la messa a terra di protezione class 1 / single insulation: protective grounding is required

 classe 2 / doppio isolamento: non necessita di messa a terra di protezione class 2 / double insulation: protective grounding is not required

 sospensione / suspension

 parete / wall

 tavolo / table

 soffitto / ceiling

 terra / floor

 parete / wall

 tavolo / table

 soffitto / ceiling

 sospensione / suspension

 terra / floor





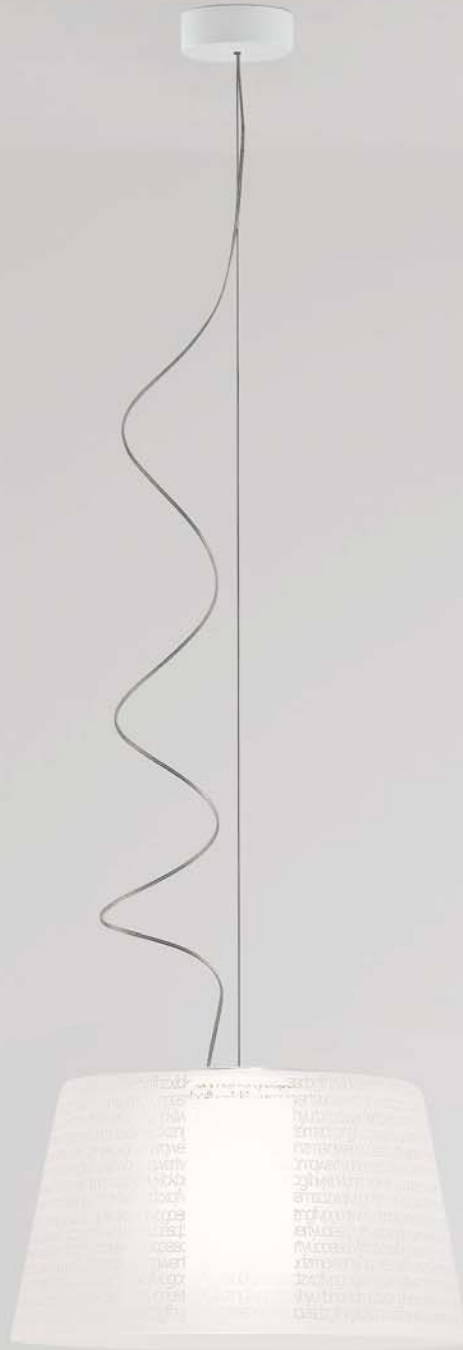

**Structure**

- > *Struttura e rosone a soffitto:*  
verniciato bianco.
- > *Diffusore:*  
cristallo con incisioni in sabbiatura.  
Filtro interno in vetro Pyrex.
- > *Structure and ceiling rose:*  
white painted.
- > *Diffuser:*  
crystal with sandblasted engravings.  
Internal screen in Pyrex glass.
- > *Struktur und Deckenrosette:*  
matt weiß lackiert.
- > *Diffusor:*  
Kristall mit sandgestrahlter Gravur.  
Innenfilter aus Pyrex-Glas.
- > *Structure et rosette:*  
verni blanc opaque.
- > *Diffuseur:*  
cristal avec gravure sablée.  
Filtre intérieure en pyrex.
- > *Estructura y florón de techo:*  
barnizado blanco opaco.
- > *Difusor:*  
cristal con incisiones arenadas.  
Filtro interno en vidrio pyrex.

**Light data**



- S1. / max 1x150W IAA E27
- S1. / max 1x150W HSGST E27
- S3.S5 / max 1x150W IAA E27
- S3.S5 / max 1x150W HSGST E27

**Model S1**

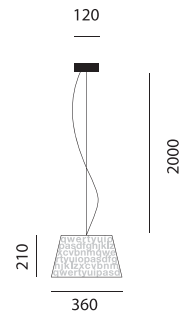

**Model S3**

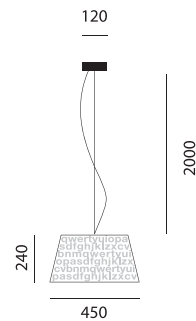

**Model S5**

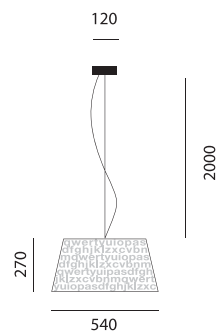

**Colors**

- white
- crystal
- black crystal





## Structure

- > *Rosone a soffitto:*  
verniciato bianco.
- > *Guscio esterno:*  
metallo (S5) o polipropilene rotazionale verniciati.
- > *Diffusore inferiore:*  
metacrilato opalino bianco termoformato.
- > *Reattore:*  
elettronico, dimmerabile a richiesta (S7).
  
- > *Ceiling rose:*  
matt white painted.
- > *Outer diffuser:*  
painted metal (S5) or polypropylene.
- > *Lower diffuser:*  
opal white thermoformed methacrylate.
- > *Ballast:*  
electronic, dimmable on request (S7).
  
- > *Deckenrosette:*  
matt weiß lackiert.
- > *Äußeres Gehäuse:*  
Polypropylen lackiert oder Metall (S5).
- > *Innere Reflektorschale:*  
matt weiß wärmegeformtes Methacrylat.
- > *Vorschaltgerät:*  
elektronisch, dimmbar auf Wunsch (S7).
  
- > *Rosette:*  
verni blanc mat.
- > *Diffuseur extérieur:*  
métal (S5) ou polypropylène verni.
- > *Réflecteur intérieur:*  
methacrylate thermoformé blanc.
- > *Ballast:*  
électronique, réglable sur demande (S7).
  
- > *Florón de techo:*  
barnizado en blanco mate.
- > *Difusor externo:*  
metal (S5) o polipropileno barnizado.
- > *Difusor inferior:*  
metacrilato opalino blanco termoformato.
- > *Reactór:*  
Bobina de reacción con dimmer opcional (S7).

## Light data



 S5 / 3x20W FBA E27

 S7 / 1x55W FSC 2GX13

## Model S5

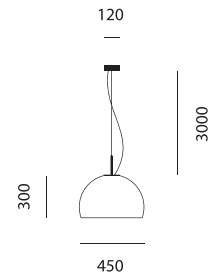

## Model S7

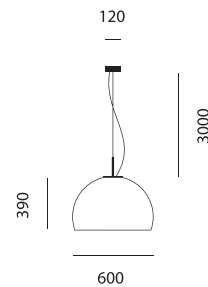

## Colors

-  glossy white
-  matt sand
-  matt or glossy black

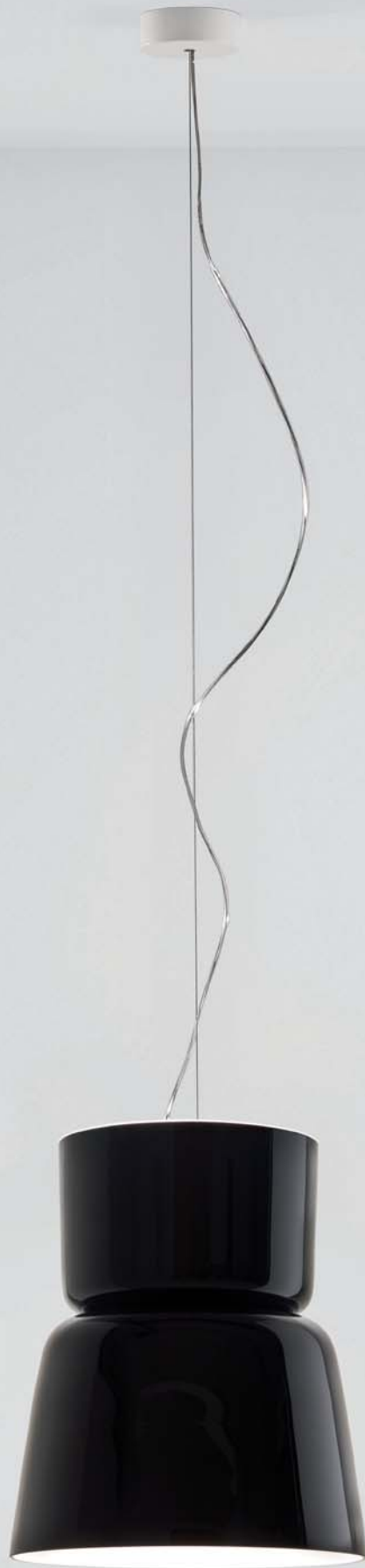



## Structure

> **Struttura e rosone a soffitto:**  
verniciato bianco.

> **Diffusore:**  
vetro soffiato opalino bianco  
o verniciato all'interno.

> **Versione LED:**  
dimmerabile a richiesta.

> **Structure and ceiling rose:**  
matt white painted.

> **Diffuser:**  
blown glass, opal white  
or painted on the inside.

> **LED version:**  
dimmable on request.

> **Struktur und Deckenrosette:**  
weiß matt lackiert.

> **Diffuser:**  
geblasenem Glas opalweiß  
oder innen lackiert.

> **Version LED:**  
dimmbar auf Wunsch.

> **Structure et rosette:**  
verni blanc opaque.

> **Diffuseur:**  
Verre soufflé blanc opalin  
ou peinte intérieurement.

> **Version LED:**  
réglable sur demande.

> **Estructura y florón de techo:**  
barnizado blanco opaco.

> **Difusor:**  
Vidrio soplado blanco mate  
o barnizado internamente.

> **Version LED:**  
regulable a petición.

## Model S5

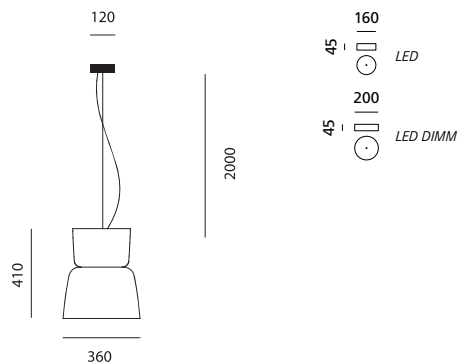

## Colors

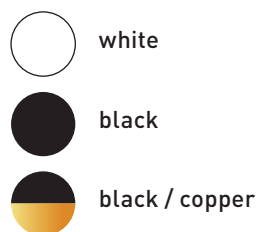

## Light data



☹ + ⚙ S5 / max 1x150W IAA E27 + max 2x60W HSGST G9

☹ + ⚙ S5 / max 1x100W HAGS/UB E27 + max 2x60W HSGST G9

☹ + ⚙ S5 / max 1x100W IRR E27+ max 2x60W HSGST G9

☹ + ⚙ S5 / max 1x23W FBT E27 + max 2x60W HSGST G9

\* LED S5 / LED 19,2W - 3000K (2100lm)

(\*) disponibile in altre versioni / other options available

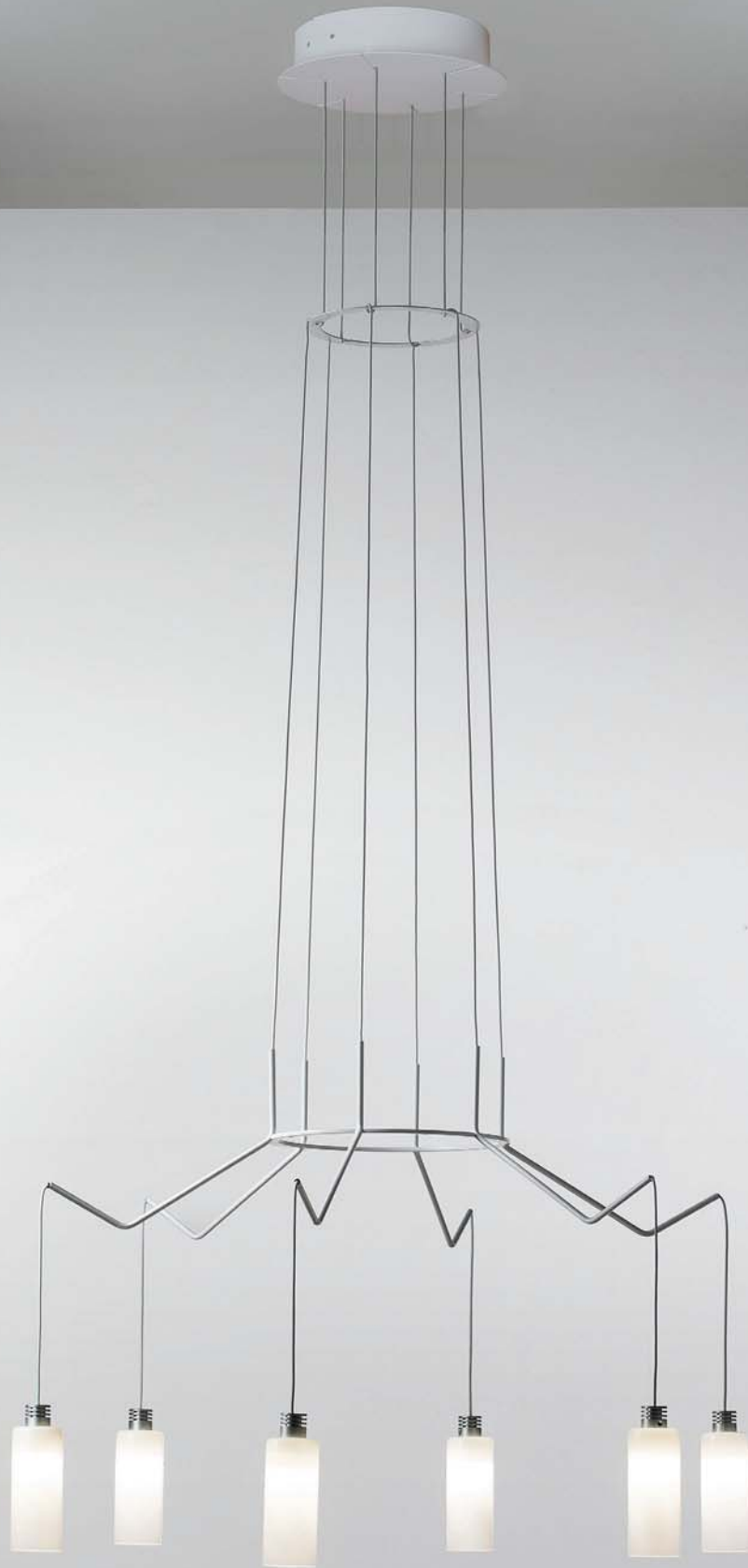

## Structure

- > *Rosone a soffitto:*  
acciaio verniciato bianco.
- > *Struttura:*  
acciaio verniciato bianco o galvanizzato ottone.
- > *Diffusore:*  
vetro Pyrex soffiato e decorato.
- > *Cavi:*  
PVC bianco extra-flessibile.
  
- > *Ceiling rose:*  
white painted steel.
- > *Structure:*  
white painted or brass galvanized steel.
- > *Diffuser:*  
decorated blown Pyrex glass.
- > *Cables:*  
white PVC extra-flexible.
  
- > *Deckenrosette:*  
weiß lackiertes Stahl.
- > *Struktur:*  
Stahl weiß lackiert oder messing-galvanisiert.
- > *Diffusor:*  
mundgeblasenes lackiertes Pyrexglas.
- > *Kabel:*  
aus PVC weiß extra flexible.
  
- > *Rosette:*  
acier verni blanc.
- > *Structure:*  
acier verni blanc ou galvanisé-laiton.
- > *Diffuseur:*  
verre pyrex soufflé et verni.
- > *Câble:*  
en PVC blanc extra flexible.
  
- > *Florón de techo:*  
acero pintado blanco.
- > *Estructura:*  
acero pintado blanco o galvanizado laton.
- > *Difusor:*  
vidrio pirex soplado y pintado.
- > *Cable:*  
en PVC blanco extra flexible.

## Light data

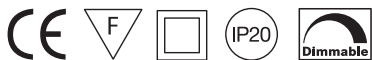

⇒ max 6x20W HSGT G4

⇒ max 6x20W XENON G4

LED 6x4,2W - 2700K (1800lm)

## Model AR6

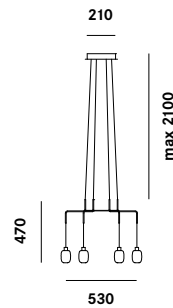

## Model AT6

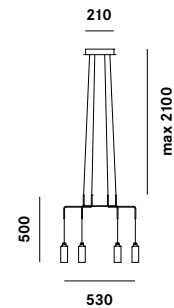

## LED

## Model BR6

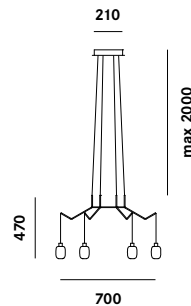

## Model BT6

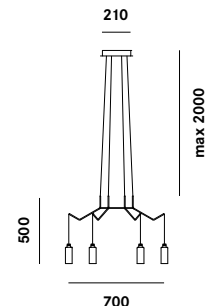

## LED

## Anello (disponibile su richiesta)

> Acciaio verniciato bianco.

Ring (available upon request)

> White painted steel.

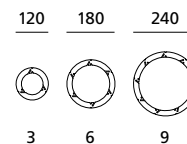

## Colors



white



brass





## Structure

- > **Rosone a soffitto:**  
acciaio verniciato bianco.
- > **Struttura:**  
acciaio verniciato bianco o galvanizzato ottone.
- > **Diffusore:**  
vetro Pyrex soffiato e decorato.
- > **Cavi:**  
PVC bianco extra-flessibile.

- > **Ceiling rose:**  
white painted steel.
- > **Structure:**  
white painted or brass galvanized steel.
- > **Diffuser:**  
decorated blown Pyrex glass.
- > **Cables:**  
white PVC extra-flexible.

- > **Deckenrosette:**  
weiß lackiertes Stahl.
- > **Struktur:**  
Stahl weiß lackiert oder messing-galvanisiert.
- > **Diffusor:**  
mundgeblasenes lackiertes Pyrexglas.
- > **Kabel:**  
aus PVC weiß extra flexible.

- > **Rosette:**  
acier verni blanc.
- > **Structure:**  
acier verni blanc ou galvanisé-laiton.
- > **Diffuseur:**  
verre pyrex soufflé et verni.
- > **Câble:**  
en PVC blanc extra flexible.

- > **Florón de techo:**  
acero pintado blanco.
- > **Estructura:**  
acero pintado blanco o galvanizado laton.
- > **Difusor:**  
vidrio pirex soplado y pintado.
- > **Cable:**  
en PVC blanco extra flexible.

## Light data

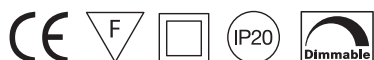

⇒ max 10x20W HSGT G4

⇒ max 10x20W XENON G4

LED 10x4,2W – 2700K (3000lm)

## Model AR6+AR3+R1

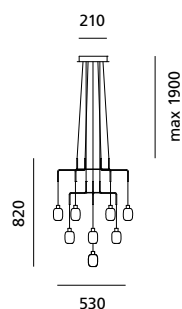

## Model BR6+AR3+R1

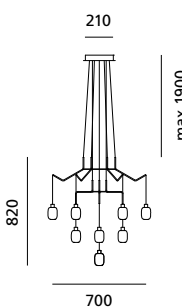

## Model AT6+AT3+T1 LED

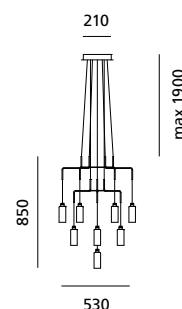

## Model BT6+AT3+T1 LED

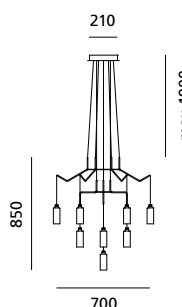

## Anello (disponibile su richiesta)

> Acciaio verniciato bianco.

Ring (available upon request)

> White painted steel.

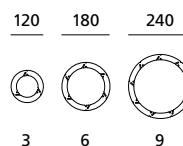

## Colors



white



brass



## Structure

- > **Rosone a soffitto:**  
acciaio verniciato bianco.
- > **Struttura:**  
acciaio verniciato bianco o galvanizzato ottone.
- > **Diffusore:**  
vetro Pyrex soffiato e decorato.
- > **Cavi:**  
PVC bianco extra-flessibile.
  
- > **Ceiling rose:**  
white painted steel.
- > **Structure:**  
white painted or brass galvanized steel.
- > **Diffuser:**  
decorated blown Pyrex glass.
- > **Cables:**  
white PVC extra-flexible.
  
- > **Deckenrosette:**  
weiß lackiertes Stahl.
- > **Struktur:**  
Stahl weiß lackiert oder messing-galvanisiert.
- > **Diffusor:**  
mundgeblasenes lackiertes Pyrexglas.
- > **Kabel:**  
aus PVC weiß extra flexible.
  
- > **Rosette:**  
acier verni blanc.
- > **Structure:**  
acier verni blanc ou galvanisé-laiton.
- > **Diffuseur:**  
verre pyrex soufflé et verni.
- > **Câble:**  
en PVC blanc extra flexible.
  
- > **Florón de techo:**  
acero pintado blanco.
- > **Estructura:**  
acero pintado blanco o galvanizado laton.
- > **Difusor:**  
vidrio pirex soplado y pintado.
- > **Cable:**  
en PVC blanco extra flexible.

## Light data

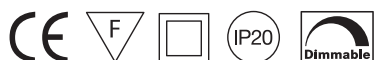

⇒ max 9/13x20W HSGT G4

⇒ max 9/13x20W XENON G4

LED 9/13x4,2W - 2700K (2700/3900lm)

## Model AR9

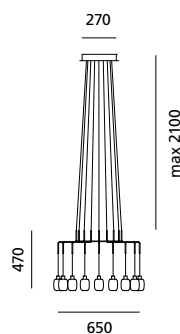

## Model AT9+AT3+T1 LED

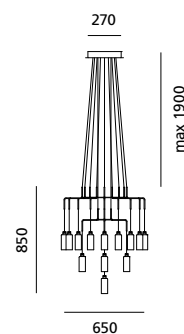

## Model BR9

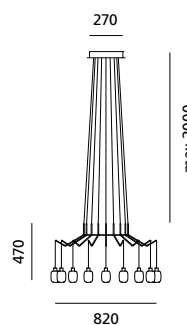

## Model BT9+AT3+T1 LED

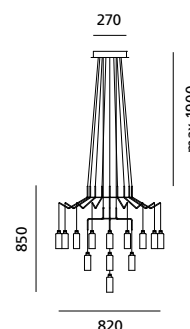

## Anello (disponibile su richiesta)

> Acciaio verniciato bianco.

## Ring (available upon request)

> White painted steel.

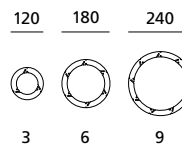

## Colors



white



brass





## Structure

- > **Struttura:**  
alluminio anodizzato.
- > **Box e rosoni:**  
in metallo verniciato bianco opaco.
- > **Diffusore:**  
vetro soffiato opalino bianco.  
Capsula interna in vetro pyrex.

- > **Structure:**  
anodized aluminium.
- > **Ceiling rose:**  
matt white painted metal.
- > **Diffuser:**  
opal white blown glass.  
Internal capsule in pyrex glass.

- > **Struktur:**  
eloxiertem Aluminium.
- > **Deckenrosette:**  
Metall weiß matt lackiert.
- > **Diffusor:**  
mundgeblasenes Glas opalweiß.  
Interne Kapsel aus Pyrexglas.

- > **Structure:**  
aluminium anodisé.
- > **Rosette:**  
métal verni blanc opaque.
- > **Diffuseur:**  
verre soufflé blanc opalin.  
Capsule interne en verre pyrex.

- > **Estructura:**  
aluminio anodizado.
- > **florón de techo:**  
para versiones multiples en metal  
barnizado blanco opaco.
- > **Diffusor:**  
vidrio soplado barnizado blanco mate.  
Capsula interna en cristal pyrex.

## Light data



- ⇒ max 1x20W HSGT G4
- ⇒ max 1x20W XENON G4
- LED 4,2W – 2700K (300lm)

## Colors



## Model S1 mini-canopy / S1 / S1L

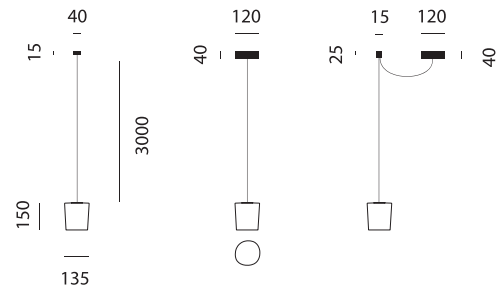

VERSIONI DECENTRATE (da 2 a 5 lampade)

SIDE VERSIONS (2 to 5 suspensions)

## Model 2L / 3L / 4L / 5L

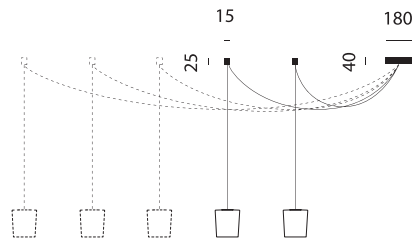

VERSIONI MULTIPLE (con box o rosone)

MULTIPLE VERSIONS (with box or ceiling rose)

## Model 3-9R / 3-9S

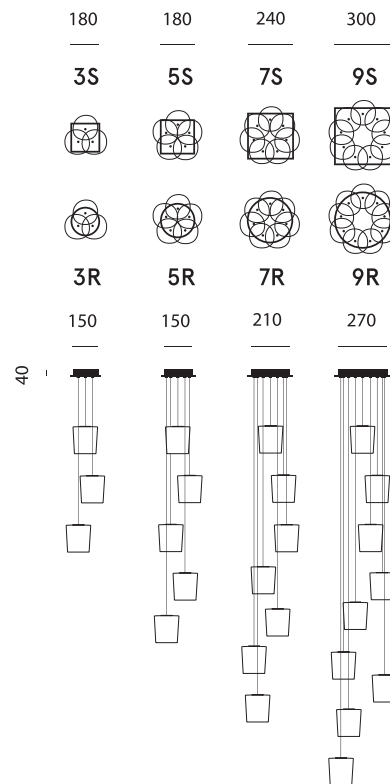



## Structure

---

- > *Rosone a soffitto:*  
verniciato bianco.
- > *Diffusore:*  
vetro soffiato opalino bianco.
- > *Versione LED:*  
dimmerabile a richiesta.
  
- > *Ceiling rosette:*  
matt white painted.
- > *Diffuser:*  
Opal white blown glass diffuser.
- > *LED version:*  
dimmable on request.
  
- > *Deckenrosette:*  
matt weiß lackiert.
- > *Diffusor:*  
geblasenem Glas opalweiß.
- > *Version LED:*  
dimmbar auf Wunsch.
  
- > *Rosette:*  
verni blanc opaque.
- > *Diffuseur:*  
Verre soufflé blanc opalin.
- > *Version LED:*  
réglable sur demande.
  
- > *Florón de techo:*  
barnizado blanco mate.
- > *Difusor:*  
vidrio soplado blanco mate.
- > *Version LED:*  
regulable a petición.

## Light data

---



 max 1x150W IAA E27

 1x23W FBT E27

\* LED 9,6W - 3000K (1034lm)

## Model S5

---

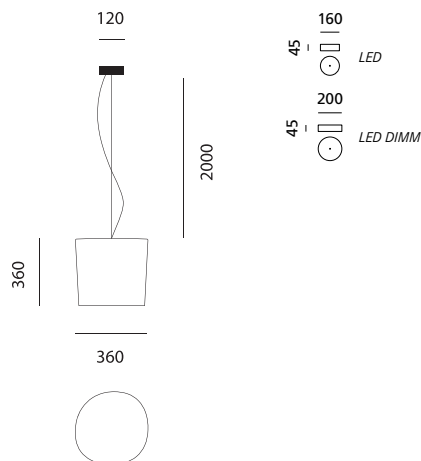

## Colors

---



(\*) disponibile in altre versioni / other options available





## Structure

---

- > *Struttura e rosone a soffitto:*  
metallo cromato o nichelato spazzolato.
- > *Diffusore:*  
vetro soffiato.
- > *Structure and ceiling rose:*  
chrome or brushed nickel metal.
- > *Diffuser:*  
blown glass.
- > *Struktur und Deckenrosette:*  
Metall verchromt oder Nickel gebürstet
- > *Diffusor:*  
geblasenes Glas.
- > *Structure et rosette*  
métal chromé ou nickel brossé.
- > *Diffuseur:*  
verre soufflé.
- > *Estructura y florón de techo:*  
metal cromado o niquel cepillado.
- > *Difusor:*  
cristal soplado.

## Light data

---



- ☛ max 1x150W IAA E27
- ☛ clear glass / max 1x150W IAA E27
- ☛ clear glass / max 1x100W HAGS/UB E27
- ☛ clear glass / max 1x100W IRR E27
- ☛ opal glass / max 1x23W FBG E27

## Model S1

---

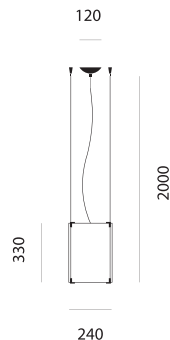

## Colors

---

- white
- TR crystal

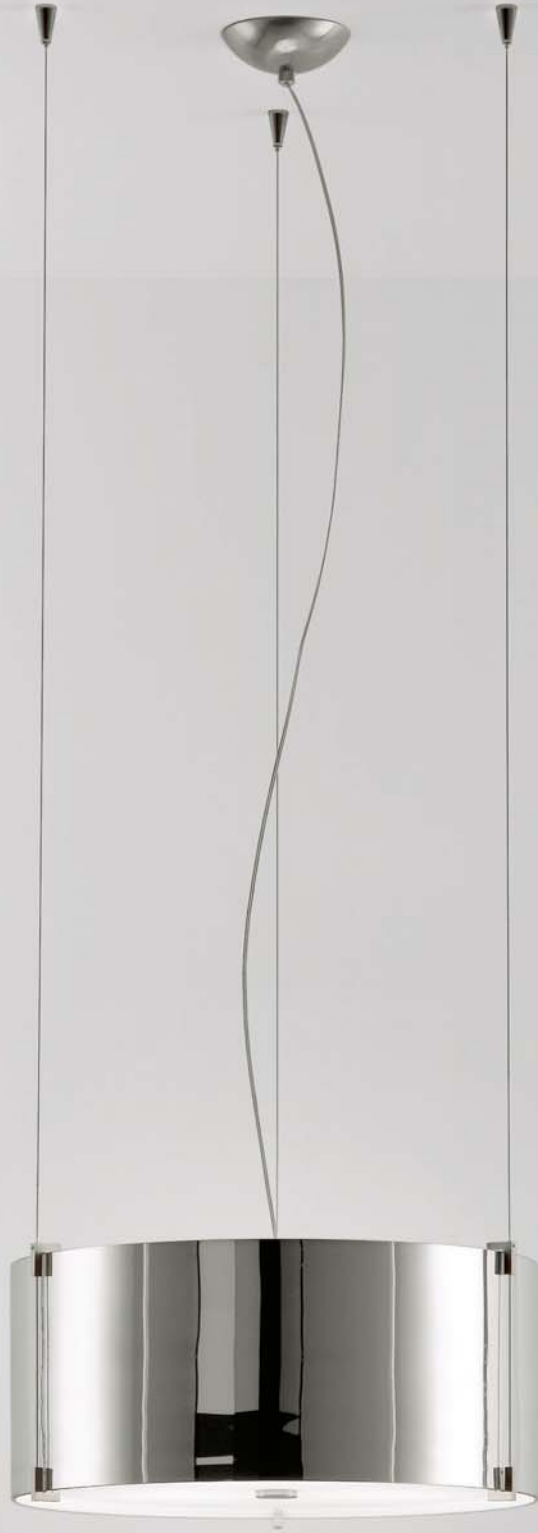



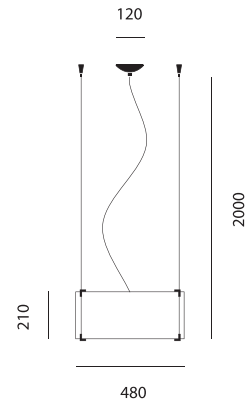

Structure

- > *Struttura e rosone a soffitto:*  
metallo cromato o nichelato spazzolato.
- > *Diffusore:*  
vetro soffiato. Dischi inferiore e superiore in metacrilato opalino bianco.
  
- > *Structure and ceiling rose:*  
chrome or brushed nickel metal.
- > *Diffuser:*  
blown glass. Upper and lower discs in white opal methacrylate
  
- > *Struktur und Deckenrosette:*  
Metall verchromt oder Nickel gebürstet
- > *Diffusor:*  
geblasenes Glas. Schirm aus Methacrylat weiß oben und unten.
  
- > *Structure et rosette*  
métal chromé ou nickel brossé.
- > *Diffuseur:*  
verre soufflé. Disques inférieurs et supérieurs en méthacrylate opalin blanc.
  
- > *Estructura y florón de techo:*  
metal cromado o niquel cepillado.
- > *Difusor:*  
cristal soplado. Discos inferior y superior en metacrilato opalino blanco.

Model S7



Colors

-  white
-  red
-  mirror
-  metallized copper

Light data



 max 3x60W IAA E27





## Structure

- > *Rosone a soffitto:*  
verniciato bianco opaco.
- > *Struttura e diffusore:*  
alluminio verniciato opaco.
- > *Reattore:*  
elettronico, dimmerabile a richiesta (ECO S3).
  
- > *Ceiling rose:*  
matt white painted.
- > *Structure and diffuser:*  
matt painted aluminium.
- > *Ballast:*  
electronic, dimmable on request (ECO S3).
  
- > *Deckenrosette:*  
weiß matt lackiert.
- > *Struktur und Leuchtenkörper:*  
Aluminium matt lackiert
- > *Vorschaltgerät:*  
elektronisch, dimmbar auf Wunsch (ECO S3).
  
- > *Rosette:*  
verni blanc mat.
- > *Structure et diffuseur:*  
aluminium verni opaque.
- > *Ballast:*  
électronique, réglable sur demande (ECO S3).
  
- > *Florón de techo:*  
barnizado blanco opaco.
- > *Estructura y difusor:*  
aluminio barnizado opaco.
- > *Reactór:*  
bobina de reacción con dimmer  
opcional (ECO S3).

## Light data



 eco S3 / 4x36W FSD 2G11 + 1x40W HMGS/UB G9

 halo S3 / 3x150W HDG R7s + 1x40W HMGS/UB G9

## Model S3

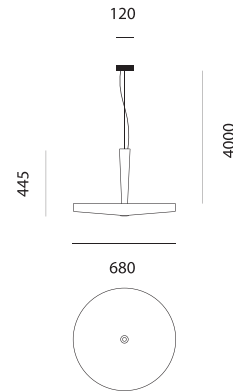

## Colors





## Structure

- > **Struttura e rosone a soffitto:**  
verniciato bianco opaco.
- > **Diffusore:**  
polietilene rotazionale bianco.
- > **Reattore:**  
elettronico, dimmerabile a richiesta.
  
- > **Structure and ceiling rose:**  
matt white painted.
- > **Diffuser:**  
white roto-moulded polyethylene.
- > **Ballast:**  
electronic, dimmable on request.
  
- > **Struktur und Deckenrosette:**  
weiß matt lackiert.
- > **Diffusor:**  
Polyethylen satiniert, hergestellt im Rotations-spritzgussverfahren.
- > **Vorschaltgerät:**  
elektronisch, dimmbar auf Wunsch.
  
- > **Rosette et structure:**  
verni blanc mat.
- > **Diffuseur:**  
polyéthylène roto blanc.
- > **Ballast:**  
électronique, réglable sur demande.
  
- > **Florón de techo y estructura:**  
barnizado blanco opaco.
- > **Difusor:**  
polietileno rotacional blanco.
- > **Reactór:**  
bobina de reacción con dimmer opcional.

## Light data



○ 1x22W FSC 2GX13 + 1x40W FSC 2GX13

## Model S33

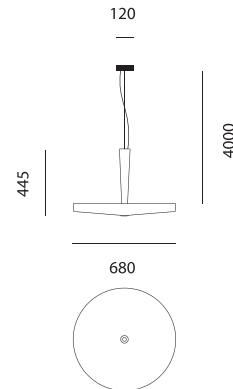

## Colors







## Structure

- > *Rosone a soffitto:*  
verniciato bianco opaco.
- > *Diffusore:*  
vetro curvato con filtro interno  
in vetro pirex bianco.
  
- > *Ceiling rose:*  
matt white painted.
- > *Diffuser:*  
curved glass with internal screen  
in white Pyrex glass.
  
- > *Deckenrosette:*  
weiß matt lackiert.
- > *Diffusor:*  
gebogenes Glas mit Innenfilter  
aus weißem Pyrex-glas.
  
- > *Rosette:*  
verni blanc mat.
- > *Diffuseur:*  
verre courbé avec filtre intérieur  
en pyrex blanc.
  
- > *Florón de techo:*  
barnizado blanco opaco.
- > *Difusor:*  
vidrio alabeado con filtro interno  
en vidrio pyrex blanco.

## Light data



☛ max 1x100W IAA E27

☛ max 1x250W HSGST E27

## Model S1

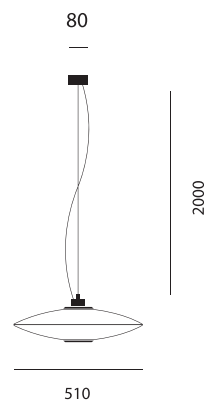

## Model S3



## Colors

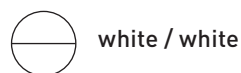

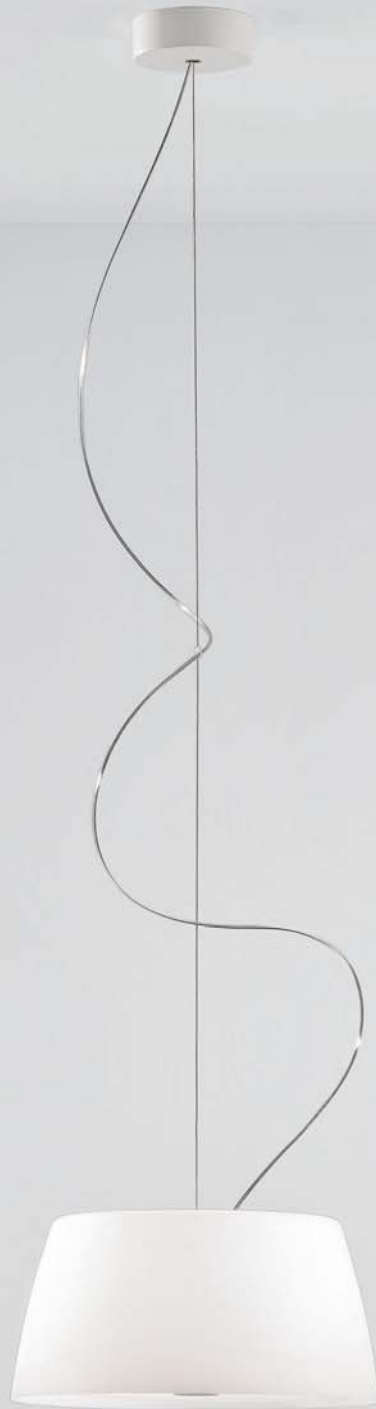

## Structure

---

- > *Struttura e rosone a soffitto:*  
verniciato bianco opaco.
- > *Diffusore:*  
polietilene rotazionale bianco.
- > *Disco inferiore:*  
metacrilato opalino satinato bianco.  
Sistema di bilanciamento manuale.

- > *Structure and ceiling rose:*  
matt white painted.
- > *Diffuser:*  
white roto-moulded polyethylene.
- > *Lower plate:*  
opal white methacrylate.  
Hand-balancing system.

- > *Struktur und Deckenrosette:*  
matt weiß lackiert.
- > *Diffusor:*  
Polyethylen satiniert, hergestellt  
im Rotationsspritzgussverfahren.
- > *Unterer Scheibe:*  
opalweiß Methacrylat.
- > *Structure et rosette:*  
verni blanc mat.
- > *Diffuseur:*  
polyéthylène roto blanc.
- > *Disque inférieur:*  
méthacrylate blanc.  
Système de balancement manuelle.

- > *Estructura y florón de techo:*  
barnizado blanco mate.
- > *Difusor:*  
polietileno rotacional blanco.
- > *Disco inferior:*  
metacrilato opalino satinado.  
Sistema de equilibrio manual.

## Light data

---



☉ S30.S50 / max 2x15W FBA E27

## Model S30

---

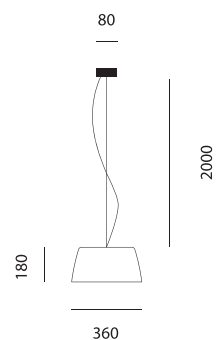

## Model S50

---

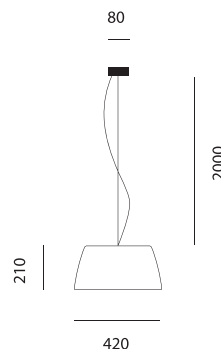

## Colors

---







## Structure

- > **Struttura:**  
alluminio anodizzato.
- > **Box e rosoni:**  
metallo verniciato bianco opaco.
- > **Diffusore:**  
vetro soffiato verniciato esternamente,  
metallizzato esternamente o con foglia oro.
  
- > **Structure:**  
anodized aluminium.
- > **Ceiling rose:**  
matt white painted metal.
- > **Diffuser:**  
blown glass painted on the outside,  
metallized on the outside or with gold leaf.
  
- > **Struktur:**  
eloxiertem Aluminium.
- > **Deckenrosette:**  
Metall weiß matt lackiert.
- > **Diffusor:**  
mundgeblasenes Glas, aussen lackiert,  
aussen metallisiert oder mit Blattgold.
  
- > **Structure:**  
aluminium anodisé.
- > **Rosaces:**  
métal verni blanc opaque.
- > **Diffuseur:**  
verre soufflé, verni à l'extérieur,  
métallisé à l'extérieur ou avec feuille d'or.
  
- > **Estructura:**  
aluminio anodizado.
- > **Florón de techo:**  
para versiones multiples en metal  
barnizado blanco opaco.
- > **Difusor:**  
vidrio soplado, pintado externamente,  
metalizado externamente o con hoja de oro.

## Light data



⇒ max 1x20W HSGT G4

⇒ max 1x20W XENON G4

LED S1 / LED 4,2W - 3000K (300lm)

## Colors



white



copper metallized  
transmirror



silver metallized  
transmirror



gold leaf



black metallized  
transmirror

## Model S1 mini-canopy / S1 / S1L

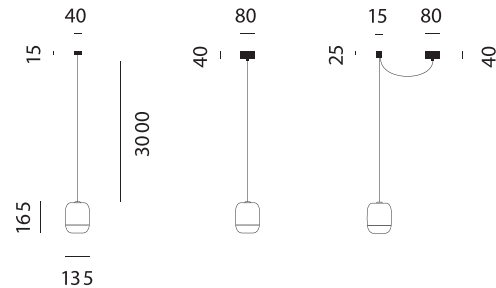

VERSIONI DECENTRATE (da 2 a 5 lampade)

SIDE VERSIONS (2 to 5 suspensions)

## Model 2L / 3L / 4L / 5L

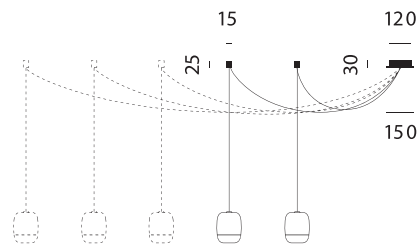

VERSIONI MULTIPLE (con box o rosone)

MULTIPLE VERSIONS (with box or ceiling rose)

## Model 3-9R / 3-9S

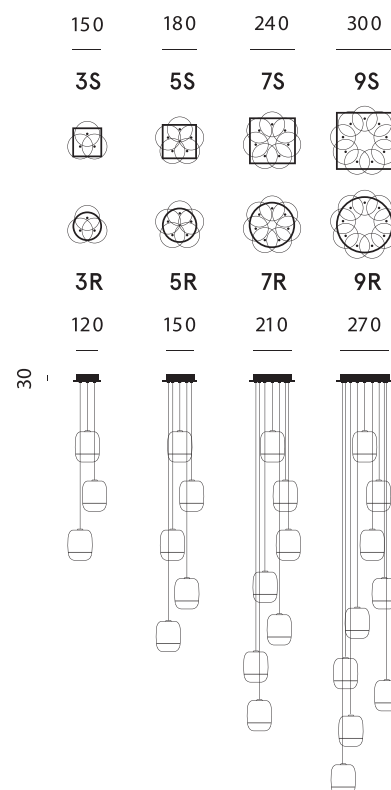



## Structure

- > **Struttura e rosone a soffitto:**  
verniciato bianco opaco.
- > **Diffusore:**  
vetro soffiato verniciato esternamente,  
metallizzato esternamente o con foglia oro.
- > **Versione LED:**  
dimmerabile a richiesta.
  
- > **Structure and ceiling rose:**  
matt white painted.
- > **Diffuser:**  
blown glass painted on the outside,  
metallized on the outside or with gold leaf.
- > **LED version:**  
dimmable on request.
  
- > **Struktur und Deckenrosette:**  
matt weiß lackiert.
- > **Leuchtenkörper:**  
mundgeblasenes Glas, aussen lackiert,  
aussen metallisiert oder mit Blattgold.
- > **Version LED:**  
dimmbar auf Wunsch.
  
- > **Structure et rosette:**  
verni blanc mat.
- > **Diffuseur:**  
verre soufflé, verni à l'extérieur,  
métallisé à l'extérieur ou avec feuille d'or.
- > **Version LED:**  
réglable sur demande.
  
- > **Estructura y florón de techo:**  
barnizado en blanco mate.
- > **Difusor:**  
vidrio soplado, pintado externamente,  
metalizado externamente o con hoja de oro.
- > **Version LED:**  
regulable a petición.

## Light data



⚡ S1 / max 1x60W HSGT G9

\* LED S1 / LED 4,8W – 3000K (720lm)

(\*) disponibile in altre versioni / other options available

## Model S1

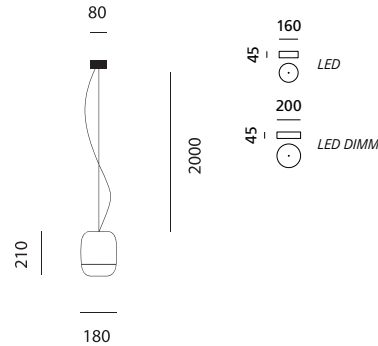

## Model S1 3R

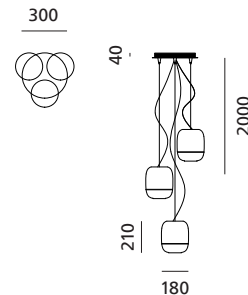

## Model S1 3B

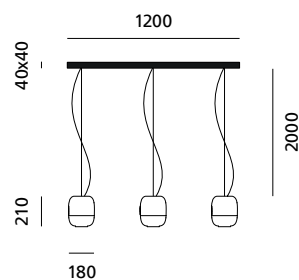

## Colors

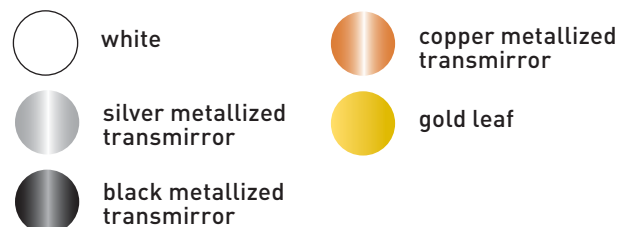

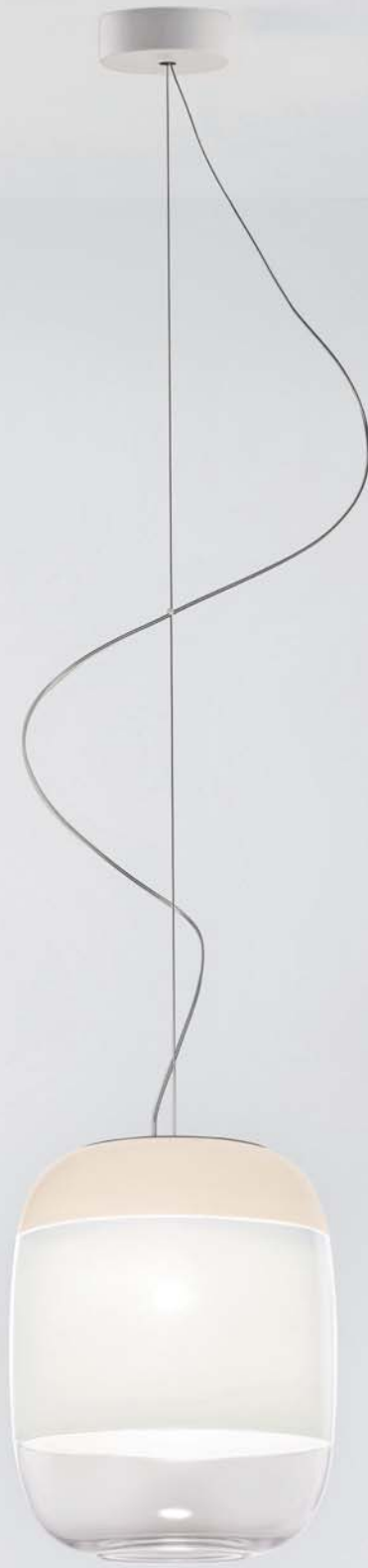



## Structure

- > **Struttura e rosone a soffitto:**  
verniciato bianco opaco.
- > **Diffusore:**  
vetro soffiato verniciato internamente,  
metallizzato esternamente o con foglia oro.
- > **Versione LED:**  
dimmerabile a richiesta.
  
- > **Structure and ceiling rose:**  
matt white painted.
- > **Diffuser:**  
blown glass painted inside,  
metallized on the outside or with gold leaf.
- > **LED version:**  
dimmable on request.
  
- > **Struktur und Deckenrosette:**  
matt weiß lackiert.
- > **Leuchtenkörper:**  
mundgeblasenes Glas, innen lackiert,  
aussen metallisiert oder mit Blattgold.
- > **Version LED:**  
dimmbar auf Wunsch.
  
- > **Structure et rosette:**  
verni blanc mat.
- > **Diffuseur:**  
verre soufflé, verni à l'intérieur,  
métallisé à l'extérieur ou avec feuille d'or.
- > **Version LED:**  
réglable sur demande.
  
- > **Estructura y florón de techo:**  
barnizado en blanco mate.
- > **Difusor:**  
vidrio soplado, pintado internamente,  
metalizado externamente o con hoja de oro.
- > **Version LED:**  
regulable a petición.

## Light data



S3.S5 / max 1x150W IAA E27

S3.S5 / max 1x100W IRR E27

S3.S5 / max 1x23W FBT E27

\* LED S3 / LED 9,6W – 3000K (1034lm)

\* LED S5 / LED 13,2W – 3000K (1417lm)

## Model S3

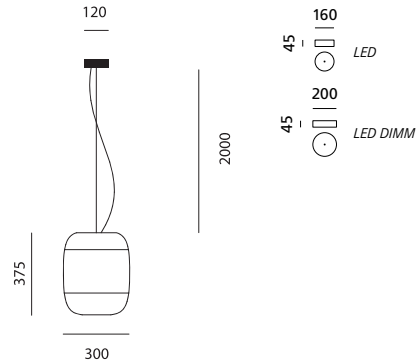

## Model S5

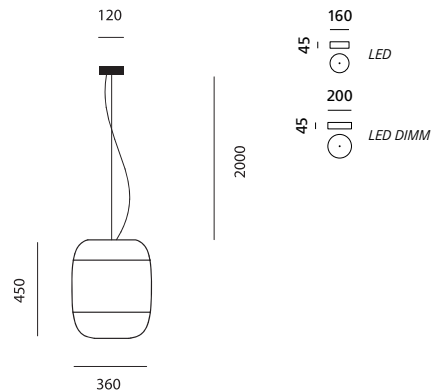

## Colors

- white / white
- black / black
- ivory / white
- metallized silver
- metallized copper
- gold leaf

(\*) disponibile in altre versioni / other options available



## Structure

---

- > *Rosone a soffitto:*  
verniciato bianco opaco.
- > *Corpo:*  
poliuretano stampato, verniciato bianco lucido o opaco.
- > *Guscio diffusore inferiore:*  
metacrilato opalino bianco termoformato.
- > *Reattore:*  
elettronico, dimmerabile a richiesta.  
Sistema di bilanciamento manuale.
  
- > *Ceiling rose:*  
matt white painted.
- > *Body:*  
matt or glossy white moulded polyurethane.
- > *Lower diffuser:*  
opal white thermoformed methacrylate.
- > *Ballast:*  
electronic, dimmable on request.  
Hand-balancing system.
  
- > *Deckenrosette:*  
mattweiß lackiert.
- > *Körper:*  
gespresstes Polyurethan,  
matt weiß oder glänzend lackiert.
- > *Untere Diffusor:*  
Methacrylat opalweiß wärmegeformt.
- > *Vorschaltgerät:*  
elektronisch, dimmbar auf Wunsch.  
Handauswuchtung.
  
- > *Rosette:*  
verni blanc mat.
- > *Corps:*  
polyuréthane moulé peint blanc mat ou brillant.
- > *Diffuseur inférieur:*  
méthacrylate thermoformé blanc opalin.
- > *Ballast:*  
électronique, réglable sur demande.  
Système de balancement manuel.
  
- > *Florón de techo:*  
barnizado blanco mate.
- > *Cuerpo:*  
poliuretano imprimido barnizado blanco brillante o opaco.
- > *Diffusor inferior:*  
PMMA blanco opalino termoformado.
- > *Reactór:*  
bobina de rección con dimmer opcional  
Sistema de equilibrio manual.

## Light data

---

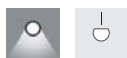

○ 1x55W FSC 2GX13

## Model S3

---

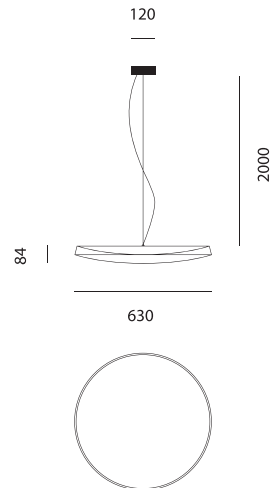

## Colors

---







## Structure

---

- > *Struttura e rosone a soffitto:*  
verniciato bianco opaco.
- > *Diffusore esterno:*  
metacrilato termoformato trasparente.
- > *Diffusore interno:*  
polietilene rotazionale opalino bianco.
- > *Reattore:*  
elettronico, dimmerabile a richiesta.
  
- > *Structure et ceiling rose:*  
matt white painted.
- > *Outer diffuser:*  
transparent thermoformed methacrylate
- > *Inner diffuser:*  
opal white roto-moulded polyethylene.
- > *Ballast:*  
electronic, dimmable on request.
  
- > *Struktur und Deckenrosette:*  
matt weiß lackiert.
- > *Außer Diffusor:*  
Methacrylat transparent wärmegeformt.
- > *Inner Diffusor:*  
Polyethylen satiniert hergestellt  
im Rotations-spritzgussverfahren.
- > *Vorschaltgerät:*  
elektronisch, dimmbar auf Wunsch.
  
- > *Structure et rosette:*  
verni blanc mat.
- > *Diffuseur extérieur:*  
méthacrylate transparent thermoformé.
- > *Diffuseur intérieur:*  
polyéthylène roto blanc.
- > *Ballast:*  
électronique, réglable sur demande.
  
- > *Estructura y florón de techo:*  
barnizado blanco mate.
- > *Difusor externo:*  
metacrilato transparente termoformado.
- > *Difusor interno:*  
polipropileno rotacional opalino blanco.
- > *Reactór:*  
bobina de rección con dimmer opcional.

## Light data

---



○ 1x55W FSC 2GX13

## Model S5

---

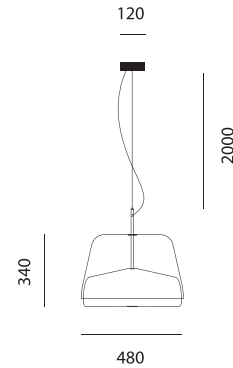

## Colors

---





## Structure

- > *Struttura e rosone a soffitto:*  
verniciato bianco o nero opaco.
- > *Diffusore inferiore:*  
metacrilato opalino bianco.
- > *Structure and ceiling rose:*  
matt white or black painted.
- > *Lower diffuser:*  
opal white methacrylate.
- > *Struktur und Deckenrosette:*  
weiß matt oder schwarz lackiert.
- > *Unterer diffusor:*  
opalweiß Methacrylat.
- > *Structure et rosette:*  
verni blanc ou noir mat.
- > *Diffuseur inférieur:*  
méthacrylate blanc opalin.
- > *Estructura y florón de techo:*  
barnizado blanco o negro mate.
- > *Difusor inferior:*  
metacrilato opalino blanco.

## Light data



\* LED 4,8W – 3000K (720lm)

(\*) disponibile in altre versioni / other options available

## Model S1.S1L

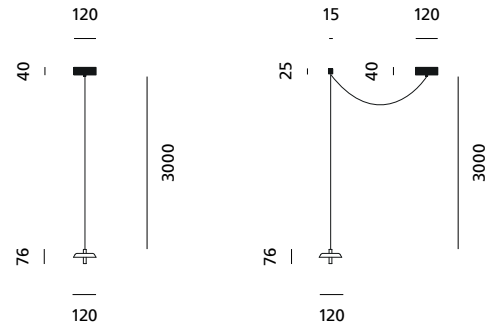

## Model S1 2L

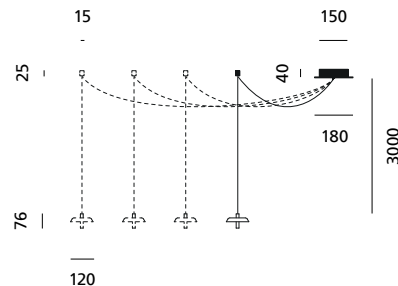

## Model S1 3B

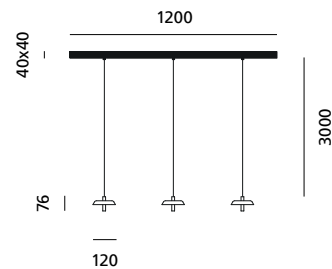

## Colors

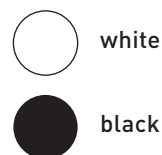

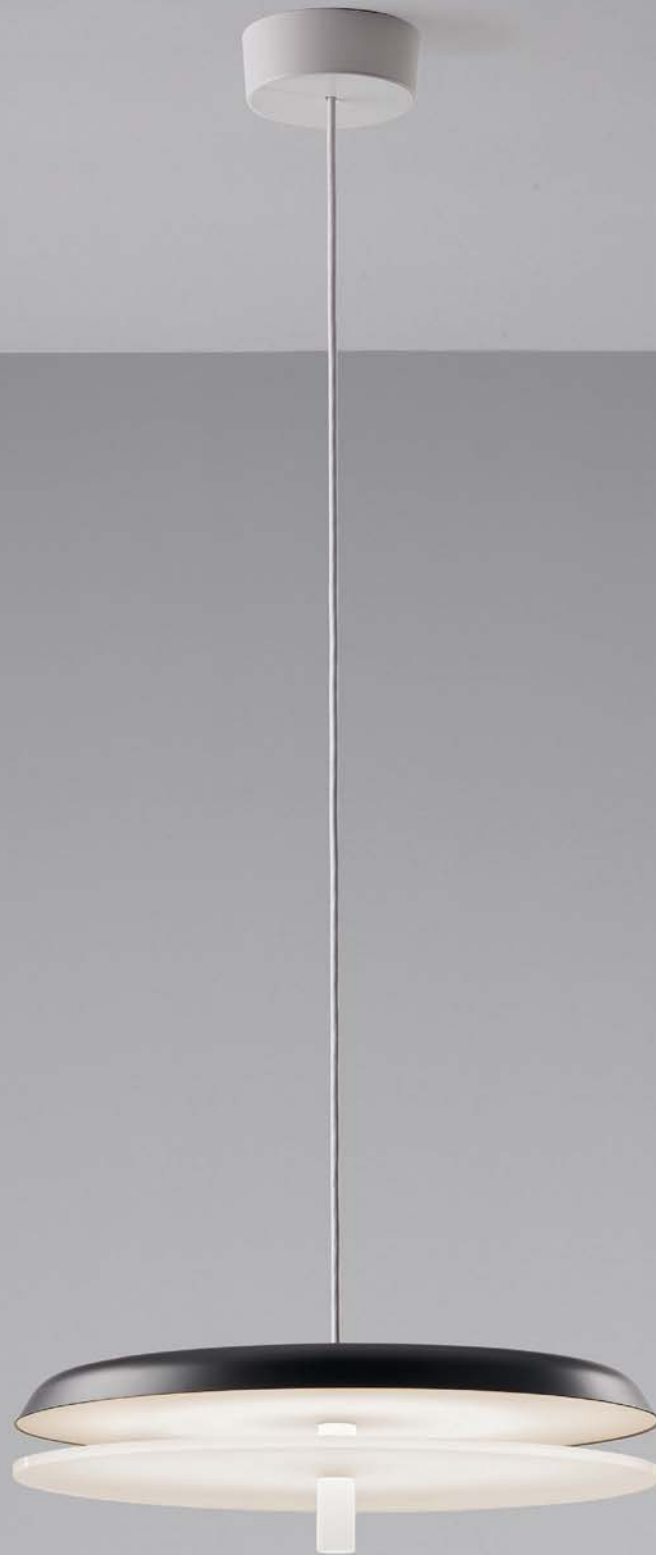



## Structure

- > *Struttura e rosone a soffitto:*  
verniciato bianco o nero opaco.
- > *Diffusore inferiore:*  
metacrilato opalino bianco.
  
- > *Structure and ceiling rose:*  
matt white or black painted.
- > *Lower diffuser:*  
opal white methacrylate.
  
- > *Struktur und Deckenrosette:*  
weiß matt oder schwarz lackiert.
- > *Unterer diffusor:*  
opalweiß Methacrylat.
  
- > *Structure et rosette:*  
verni blanc ou noir mat.
- > *Diffuseur inférieur:*  
méthacrylate blanc opalin.
  
- > *Estructura y florón de techo:*  
barnizado blanco o negro mate.
- > *Difusor inferior:*  
metacrilato opalino blanco.

## Light data



\* S3 / LED 30W - 2700K (2850lm)

\* S5 / LED 55W - 2700K (5150lm)

(\*) disponibile in altre versioni / other options available

## Model S3

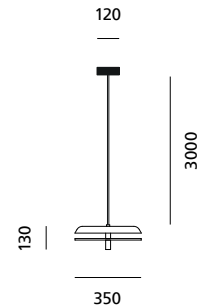

## Model S5

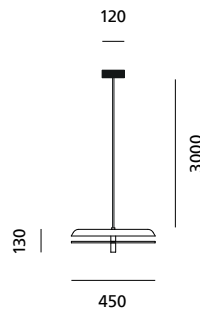

## Colors

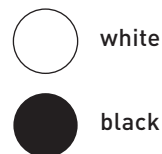

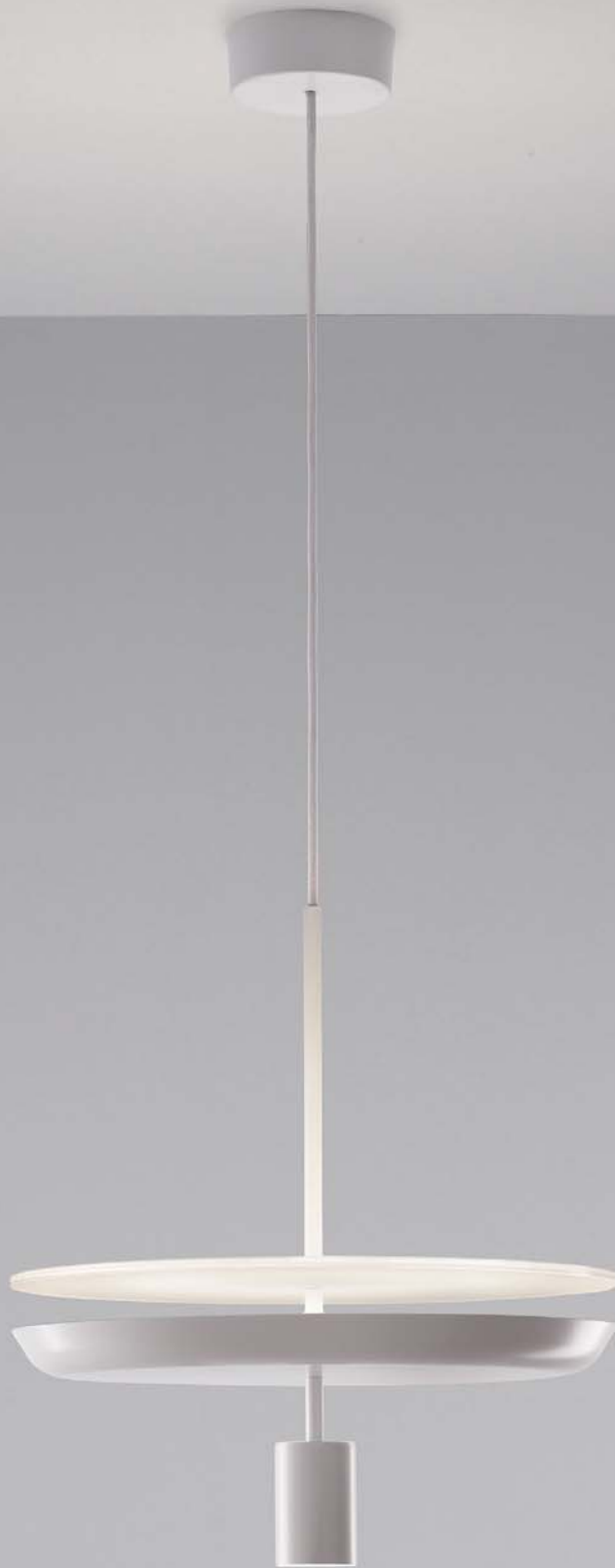

## Structure

- > *Struttura e rosone a soffitto:*  
verniciato bianco o nero opaco.
- > *Diffusore:*  
verniciato bianco/nero opaco  
o galvanizzato cromo/ottone.
- > *Diffusore superiore:*  
metacrilato opalino bianco.
  
- > *Structure and ceiling rose:*  
matt white or black painted.
- > *Diffusore:*  
matt white/black painted  
or chrome/brass galvanized.
- > *Upper diffuser:*  
opal white methacrylate.
  
- > *Struktur und Deckenrosette:*  
weiß matt oder schwarz lackiert.
- > *Diffusor:*  
weiß matt, schwarz lackiert, verchromt  
oder messing-galvanisiert.
- > *Oberer Diffusor:*  
opalweiß Methacrylat.
  
- > *Structure et rosette:*  
verni blanc ou noir mat.
- > *Diffuseur:*  
blanc mat, noir mat, chromé  
ou galvanisé-laiton.
- > *Diffuseur supérieur:*  
méthacrylate blanc opalin.
  
- > *Estructura y florón de techo:*  
barnizado blanco o negro mate.
- > *Difusor:*  
blanco mate, negro mate,  
cromado o galvanizado laton.
- > *Difusor superior:*  
metacrilato opalino blanco.

## Light data



\* S50 / LED 55W - 2700K (5150lm)

\* S55 / LED 55W - 2700K (5150lm)

(\*) disponibile in altre versioni / other options available

## Model S50

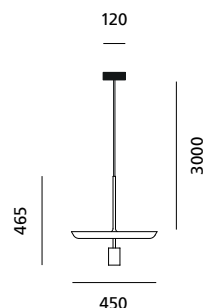

## Model S55

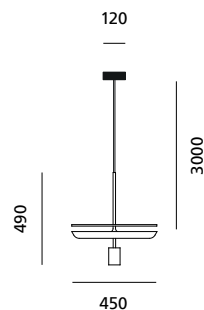

## Colors







## Structure

- > *Struttura e rosone a soffitto:*  
verniciato bianco o nero opaco.
- > *Diffusore:*  
verniciato bianco/nero opaco  
o galvanizzato cromo/ottone.
- > *Diffusore superiore:*  
metacrilato opalino bianco.
  
- > *Structure and ceiling rose:*  
matt white or black painted.
- > *Diffusore:*  
matt white/black painted  
or chrome/brass galvanized.
- > *Upper diffuser:*  
opal white methacrylate.
  
- > *Struktur und Deckenrosette:*  
weiß matt oder schwarz lackiert.
- > *Diffusor:*  
weiß matt, schwarz lackiert, verchromt  
oder messing-galvanisiert.
- > *Oberer Diffusor:*  
opalweiß Methacrylat.
  
- > *Structure et rosette:*  
verni blanc ou noir mat.
- > *Diffuseur:*  
blanc mat, noir mat, chromé  
ou galvanisé-laiton.
- > *Diffuseur supérieur:*  
méthacrylate blanc opalin.
  
- > *Estructura y florón de techo:*  
barnizado blanco o negro mate.
- > *Difusor:*  
blanco mate, negro mate,  
cromado o galvanizado laton
- > *Difusor superior:*  
metacrilato opalino blanco.

## Model S70

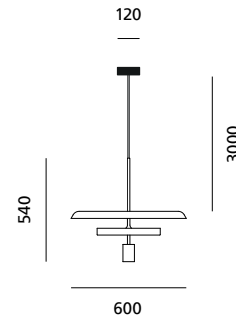

## Colors



## Light data



- \* S50 / LED 55W – 2700K (5150lm)
- + max 6W DRPAR GU10

(\*) disponibile in altre versioni / other options available



## Structure

---

- > *Struttura e rosone a soffitto:*  
verniciato bianco opaco.
- > *Diffusore superiore:*  
vetro sabbiato.
- > *Structure and ceiling rose:*  
matt white painted.
- > *Upper diffuser:*  
sanblasted glass.
- > *Struktur und Deckenrosette:*  
weiß matt lackiert.
- > *Oberer Diffusor:*  
sandgestrahltes Glas.
- > *Structure et rosette:*  
verni blanc mat.
- > *Diffuseur supérieur:*  
verre sablé.
- > *Estructura y florón de techo:*  
barnizado blanco mate.
- > *Difusor superior:*  
vidrio arenado.

## Light data

---



- \* S50 / LED 55W - 2700K (5150lm)
- + max 6W DRPAR GU10

(\*) disponibile in altre versioni / other options available

## Model S70

---

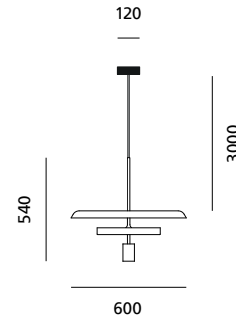

## Colors

---







## Structure

---

- > *Struttura e rosone a soffitto:*  
verniciato bianco o nero opaco.
- > *Diffusore inferiore:*  
metacrilato opalino bianco.
- > *Structure and ceiling rose:*  
matt white or black painted.
- > *Lower diffuser:*  
opal white methacrylate.
- > *Struktur und Deckenrosette:*  
weiß matt oder schwarz lackiert.
- > *Unterer diffusor:*  
opalweiß Methacrylat.
- > *Structure et rosette:*  
verni blanc ou noir mat.
- > *Diffuseur inférieur:*  
méthacrylate blanc opalin.
- > *Estructura y florón de techo:*  
barnizado blanco o negro mate.
- > *Difusor inferior:*  
metacrilato opalino blanco.

## Light data

---



\* LED 30W + 25W - 2700K (5150lm)

(\*) disponibile in altre versioni / other options available

## Model S3

---

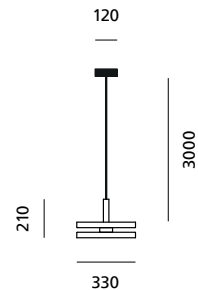

## Colors

---

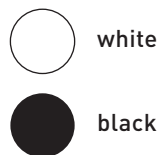



## Structure

- > *Struttura e rosone a soffitto:*  
verniciato bianco o nero opaco  
con regolazione dell'altezza.
- > *Diffusore inferiore:*  
metacrilato opalino bianco.
- > *Versione LED:*  
dimmerabile a richiesta.

- > *Structure and ceiling rose:*  
matt white or black painted  
with height regulation.
- > *Lower diffuser:*  
opal white methacrylate.
- > *LED version:*  
dimmable on request.

- > *Struktur und Deckenrosette:*  
weiß matt oder schwarz lackiert  
höhenverstellbar.
- > *Unterer diffusor:*  
opalweiß Methacrylat.
- > *Version LED:*  
dimmbar auf Wunsch.

- > *Structure et rosette:*  
verni blanc ou noir mat  
règlable en hauteur.
- > *Diffuseur inférieur:*  
méthacrylate blanc.
- > *Version LED:*  
réglable sur demande.

- > *Estructura y florón de techo:*  
barnizado blanco o negro mate  
ajustable en altura.
- > *Difusor inferior:*  
metacrilato opalino blanco.
- > *Version LED:*  
regulable a petición.

## Light data



\* LED 30W + 25W – 2700K (5150lm)

(\*) disponibile in altre versioni / other options available

## Model S3

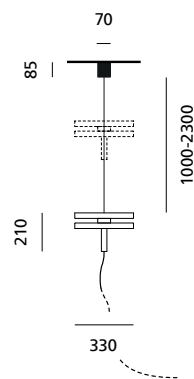

## Colors

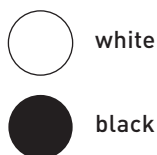





### Structure

- > **Rosone a soffitto:**  
verniciato bianco opaco.
- > **Struttura:**  
lastra in polipropilene opalino.
- > **Diffusore:**  
involucro sfoderabile e lavabile in microfibra poliestere bianco.
- > **Reattore:**  
elettronico, dimmerabile a richiesta (ECO 33S).  
Versione LED, dimmerabile a richiesta.
- > **Ceiling rose:**  
matt white painted.
- > **Structure:**  
opal polypropylene slab
- > **Diffuser:**  
white polyester micro-fibre fabric, removable and washable.
- > **Ballast:**  
electronic, dimmable on request (ECO 33S).  
LED version, dimmable on request.
- > **Deckenrosette:**  
matt weiß lackiert.
- > **Struktur:**  
weiß gebogen Polypropylenplatte.
- > **Diffusor:**  
Polyester Mikrofasergerewebe weiß, abnehmbar und waschbar.
- > **Vorschaltgerät:**  
elektronisch, dimmbar auf Wunsch (ECO 33S).  
Version LED, dimmbar auf Wunsch.
- > **Rosette:**  
verni blanc mat.
- > **Structure:**  
armature en polypropylène opale.
- > **Diffuseur:**  
hausse déhoussable et lavable in microfibre polyester blanc.
- > **Ballast:**  
électronique, réglable sur demande (ECO 33S).  
Version LED, réglable sur demande.
- > **Florón de techo:**  
barnizado blanco mate.
- > **Estructura:**  
lastra en polipropileno opalino.
- > **Difusor:**  
envoltorio extraíble y lavable en microfibra poléster blanco.
- > **Reactór:**  
Bobina de rección con dimmer opcional (ECO 33S).  
Version LED, regulable a petición.

### Light data



33S / 1x55W FSDH 2G11

34S / 1x55/80W FSDH 2G11

34S6 / 2x55W FSDH 2G11

LED 33S / 31,5W – 3000K (4320lm)

LED 34S / 31,5W – 3000K (4320lm)

LED 34S6 / 57,9W – 3000K (7920lm)

### Model 33S

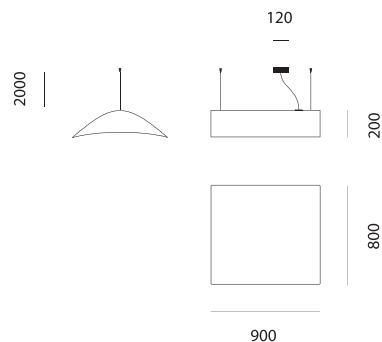

### Model 34S

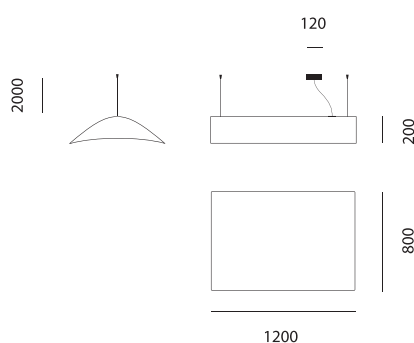

### Model 34S6

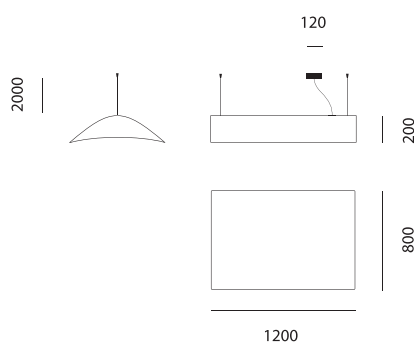

### Colors



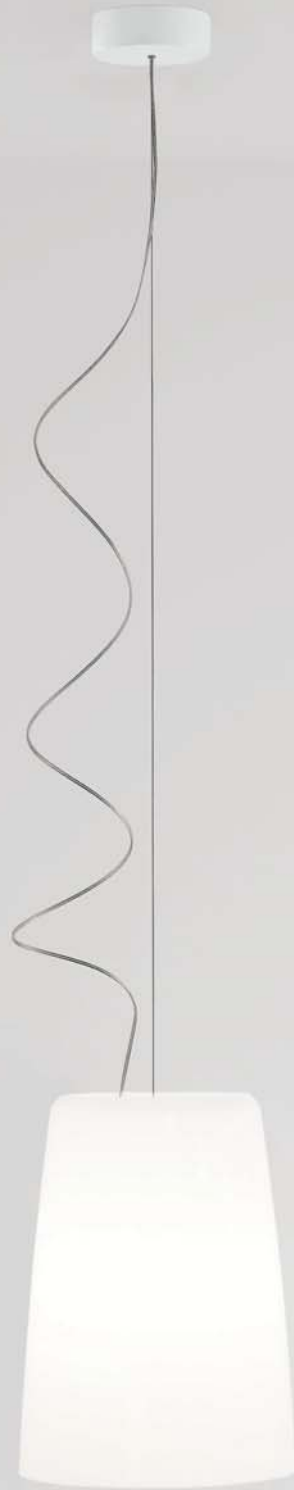

## Structure

- > **Rosone a soffitto:**  
verniciato bianco opaco.
- > **Diffusore:**  
vetro soffiato bianco satinato.
- > **Versione LED:**  
dimmerabile a richiesta.
  
- > **Ceiling rose:**  
matt white painted.
- > **Diffuser:**  
opal white blown glass diffuser.
- > **LED version:**  
dimmable on request.
  
- > **Deckenrosette:**  
weiß matt lackiert.
- > **Diffusor:**  
geblasenes Glas satiniert.
- > **Version LED:**  
dimmbar auf Wunsch.
  
- > **Rosette:**  
verni blanc mat.
- > **Diffuseur:**  
verre soufflé blanc opalin.
- > **Version LED:**  
réglable sur demande.
  
- > **Florón de techo:**  
barnizado blanco mate.
- > **Difusor:**  
vidrio soplado blanco satinado.
- > **Version LED:**  
regulable a petición.

## Light data



Small S1 / max 1x20W FBA E27

S1 / max 1x20W FBA E27

S3 / max 1x20W FBA E27

\* LED SMALL S1 / LED 4,8W – 3000K (720lm)

\* LED S1 / LED 4,8W – 3000K (720lm)

\* LED S3 / LED 9,6W – 3000K (1034lm)

(\*) disponibile in altre versioni / other options available

## Model SMALL S1

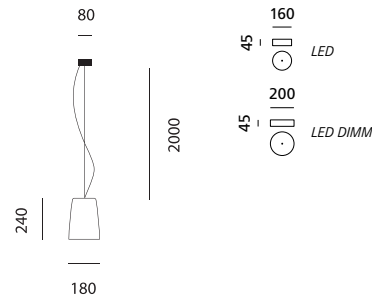

## Model S1

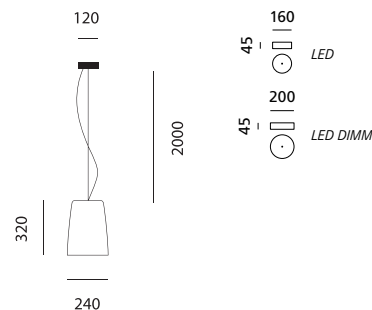

## Model S3

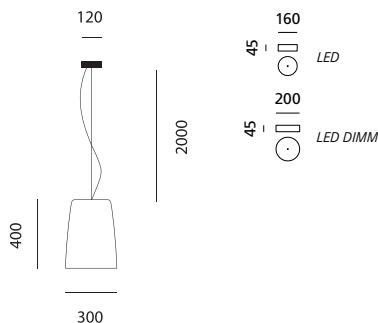

## Colors



white





## Structure

- > *Rosone a soffitto:*  
verniciato bianco opaco.
- > *Diffusore:*  
vetro soffiato.  
Sistema di bilanciamento manuale (S1).
- > *Versione LED:*  
dimmerabile a richiesta.
  
- > *Ceiling rose:*  
matt white painted.
- > *Diffuser:*  
blown glass. Hand-balancing system (S1).
- > *LED version:*  
dimmable on request.
  
- > *Deckenrosette:*  
weiß matt lackiert.
- > *Diffusor:*  
geblasenes Glas. Handauswuchtung (S1).
- > *Version LED:*  
dimmbar auf Wunsch.
  
- > *Rosette:*  
verni blanc mat.
- > *Diffuseur:*  
verre soufflé.  
Système de balancement manuel (S1).
- > *Version LED:*  
réglable sur demande.
  
- > *Florón de techo:*  
barnizado blanco mate.
- > *Difusor:*  
cristal soplado. Sistema de equilibrio manual (S1).
- > *Version LED:*  
regulable a petición.

## Light data



- S1 / max 1x75W HSGST G9
- S3 / max 1x150W IAA E27
- S3 / max 1x150W HSGST E27
- S3 / max 1x100W HAGS/UB E27
- S3 / max 1x100W IRR E27
- S3 / 1x23W FBT E27
- \* LED S1 / LED 4,8W – 3000K (720lm)
- \* LED S3 / LED 9,6W – 3000K (1034lm)

(\*) disponibile in altre versioni / other options available

## Model S1

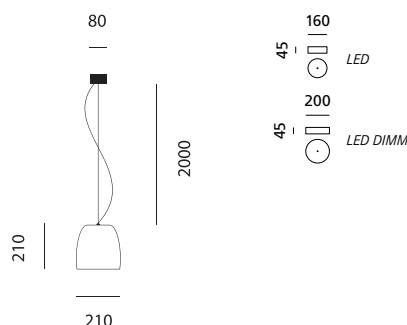

## Model S3

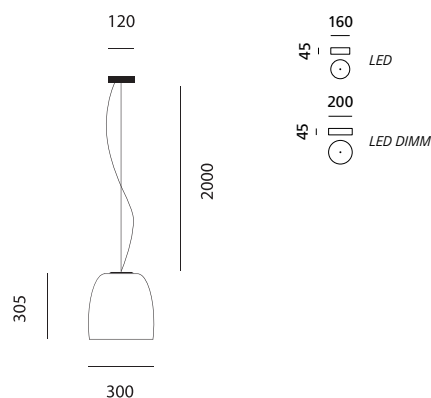

## Colors

- white
- mirror / white
- black / white
- black / gold
- copper / white
- gold leaf



## Structure

- > **Rosone a soffitto:**  
verniciato bianco opaco.
- > **Diffusore:**  
metallo verniciato.  
Sistema di bilanciamento manuale (S1).
- > **Versione LED:**  
dimmerabile a richiesta.
  
- > **Ceiling rose:**  
matt white painted.
- > **Diffuser:**  
painted metal. Hand-balancing system (S1).
- > **LED version:**  
dimnable on request.
  
- > **Deckenrosette:**  
weiß matt lackiert.
- > **Diffusor:**  
lackiertem Metall. Handauswuchtung (S1).
- > **Version LED:**  
dimmbar auf Wunsch.
  
- > **Rosette:**  
verni blanc mat.
- > **Diffuseur:**  
métal verni.  
Système de balancement manuel (S1).
- > **Version LED:**  
réglable sur demande.
  
- > **Florón de techo:**  
barnizado blanco mate.
- > **Difusor:**  
metal pintado. Sistema de equilibrio manual (S1).
- > **Version LED:**  
regulable a petición.

## Light data



- S1 / max 1x75W HSGST G9
- S3 / max 1x150W IAA E27
- S3 / max 1x150W HSGST E27
- S3 / max 1x100W HAGS/UB E27
- S3 / max 1x100W IRR E27
- S3 / 1x23W FBT E27
- \* LED S1 / LED 4,8W – 3000K (720lm)
- \* LED S3 / LED 9,6W – 3000K (1034lm)

(\*) disponibile in altre versioni / other options available

## Model S1

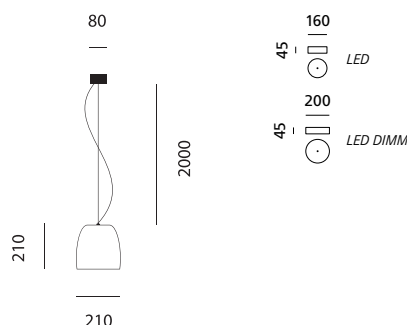

## Model S3

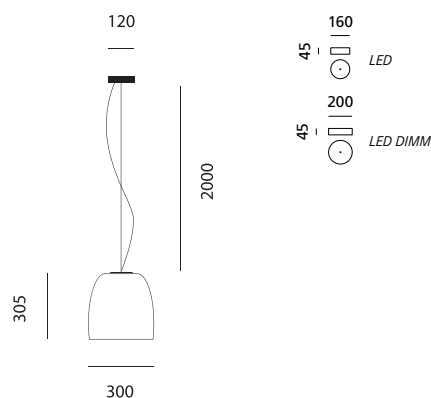

## Colors

- white / white
- white / orange
- white / gold
- black / white
- black / gold





## Structure

- > *Rosone a soffitto:*  
verniciato bianco opaco.
- > *Diffusore:*  
vetro soffiato.
- > *Versione LED:*  
dimmerabile a richiesta.
  
- > *Ceiling rose:*  
white painted.
- > *Diffuser:*  
blown glass.
- > *LED version:*  
dimmable on request.
  
- > *Deckenrosette:*  
weiß lackiert.
- > *Diffusor:*  
geblasenes Glas.
- > *Version LED:*  
dimmbar auf Wunsch.
  
- > *Rosette:*  
verni blanc mat.
- > *Diffuseur:*  
verre soufflé.
- > *Version LED:*  
réglable sur demande.
  
- > *Florón de techo:*  
barnizado blanco mate.
- > *Difusor:*  
cristal soplado.
- > *Version LED:*  
regulable a petición.

## Light data



- S5.S7 / max 1x150W IAA E27
- S5.S7 / max 1x150W HSGST E27
- S5.S7 / max 1x100W HAGS/UB E27
- S5.S7 / max 1x100W IRR E27
- S5.S7 / 1x23W FBT E27
- \* LED S5 / LED 9,6W – 3000K (1034lm)
- \* LED S7 / LED 13,2W – 3000K (1417lm)

(\*) disponibile in altre versioni / other options available

## Model S5

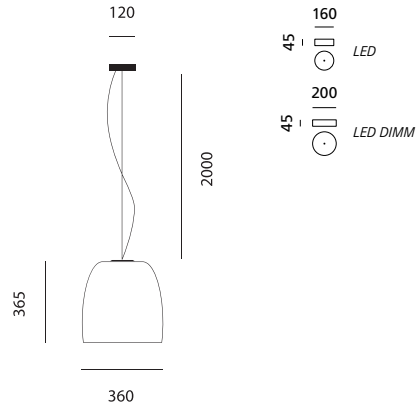

## Model S7

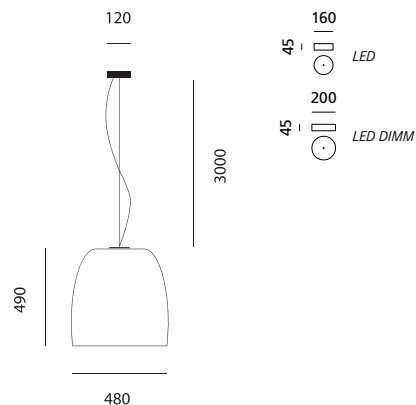

## Colors

- white
- mirror / white
- black / white
- black / gold
- copper / white
- gold leaf



## Structure

- > *Rosone a soffitto:*  
verniciato bianco opaco.
- > *Diffusore:*  
metallo verniciato.
- > *Versione LED:*  
dimmerabile a richiesta.

- > *Ceiling rose:*  
white painted.
- > *Diffuser:*  
painted metal.
- > *LED version:*  
dimnable on request.

- > *Deckenrosette:*  
weiß lackiert.
- > *Diffusor:*  
lackiertem Metall.
- > *Version LED:*  
dimmbar auf Wunsch.

- > *Rosette:*  
verni blanc mat.
- > *Diffuseur:*  
métal verni.
- > *Version LED:*  
réglable sur demande.

- > *Florón de techo:*  
barnizado blanco mate.
- > *Difusor:*  
metal pintado.
- > *Version LED:*  
regulable a petición.

## Light data



- S5.S7 / max 1x150W IAA E27
- S5.S7 / max 1x150W HSGST E27
- S5.S7 / max 1x100W HAGS/UB E27
- S5.S7 / max 1x100W IRR E27
- S5.S7 / 1x23W FBT E27

- \* LED S5 / LED 9,6W – 3000K (1034lm)
- \* LED S7 / LED 13,2W – 3000K (1417lm)

(\*) disponibile in altre versioni / other options available

## Model S5

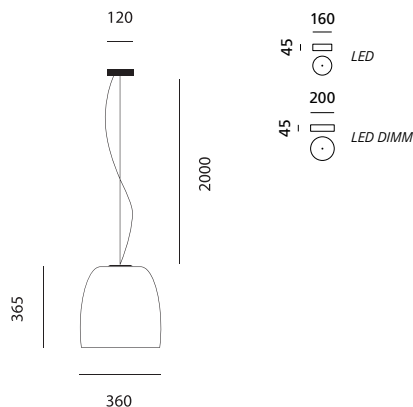

## Model S7

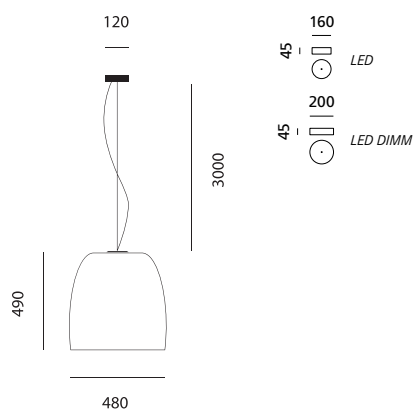

## Colors

- white / white
- white / orange
- white / gold
- black / white
- black / gold

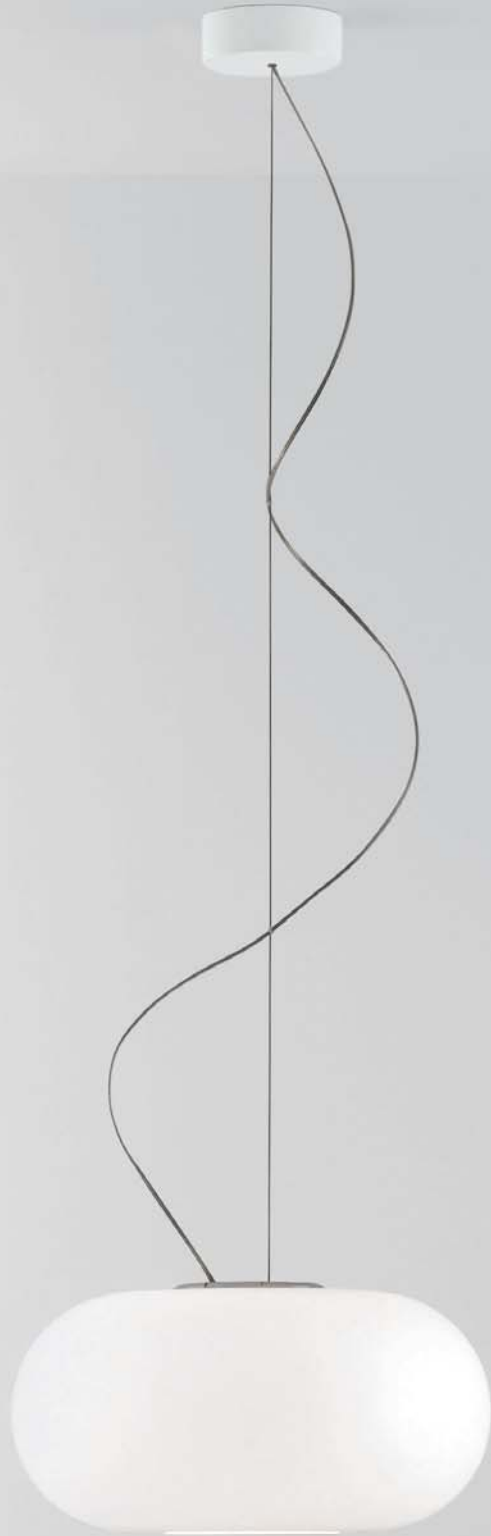



# OVER S3.S5 Mengotti / Prandina - 2003

## Structure

- > **Rosone a soffitto:**  
verniciato bianco opaco.
- > **Diffusore:**  
vetro soffiato opalino satinato bianco.
- > **Versione LED:**  
dimmerabile a richiesta.
  
- > **Ceiling rose:**  
matt white painted.
- > **Diffuser:**  
satin white opal blown glass.
- > **LED version:**  
dimmable on request.
  
- > **Deckenrosette:**  
weiß lackiert.
- > **Diffusor:**  
geblasenes Glas opalweiß.
- > **Version LED:**  
dimmbar auf Wunsch.
  
- > **Rosette:**  
verni blanc mat.
- > **Diffuseur:**  
verre opalin soufflé satiné blanc.
- > **Version LED:**  
réglable sur demande.
  
- > **Florón de techo:**  
barnizado blanco mate.
- > **Difusor:**  
cristal soplado opalino satinado blanco.
- > **Version LED:**  
regulable a petición.

## Light data



max 1x100W IAA E27

max 1x150W HSGST E27

\* LED S3 / LED 9,6W – 3000K (1034lm)

\* LED S5 / LED 9,6W – 3000K (1034lm)

(\*) disponibile in altre versioni / other options available

## Model S3

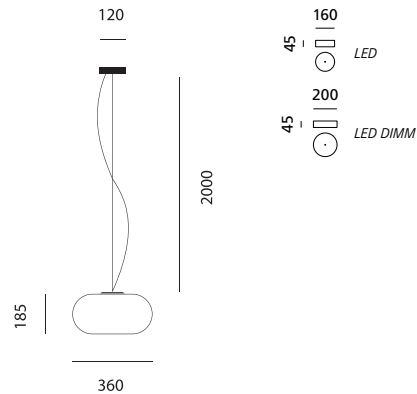

## Model S5

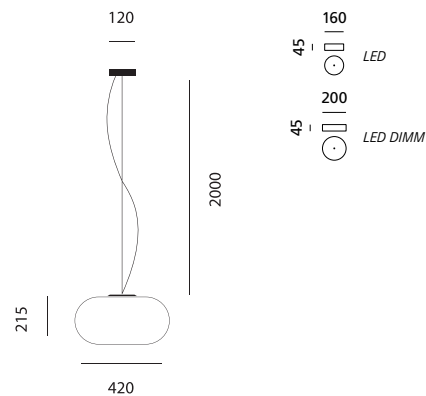

## Colors



white



## Structure

- > *Rosone a soffitto:*  
verniciato bianco opaco.
- > *Diffusore:*  
vetro soffiato opalino bianco.
  
- > *Ceiling rose:*  
matt white painted.
- > *Diffuser:*  
opal white blown glass.
  
- > *Deckenrosette:*  
weiß lackiert.
- > *Diffusor:*  
geblasenes Glas opalweiß.
  
- > *Rosette:*  
verni blanc mat.
- > *Diffuseur:*  
verre opalin soufflé blanc.
  
- > *Florón de techo:*  
barnizado blanco mate.
- > *Difusor:*  
cristal soplado opalino blanco.

## Light data



max 1x150W IAA E27

max 1x100W IRR E27

1x23W FBT E27

\* LED S1 / LED 4,8W – 3000K (720lm)

\* LED S3 / LED 9,6W – 3000K (1034lm)

\* LED S5 / LED 13,2W – 3000K (1417lm)

(\*) disponibile in altre versioni / other options available

## Colors



## Model S1

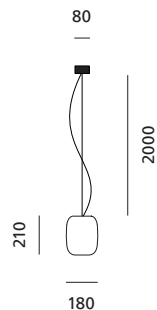

## Model S1 3R

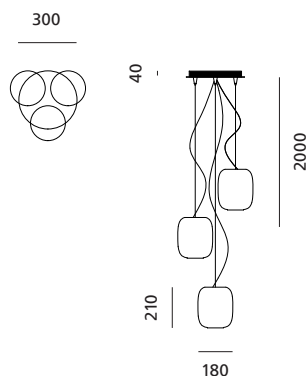

## Model S3

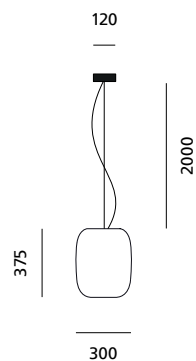

## Model S5

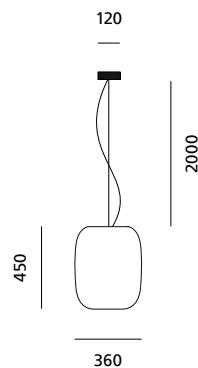





## Structure

- > *Rosone a soffitto:*  
verniciato bianco opaco.
- > *Corpo:*  
galvanizzato ottone o rame.
- > *Diffusore:*  
vetro soffiato opalino bianco  
o verniciato nero lucido.
  
- > *Ceiling rose:*  
matt white painted.
- > *Body:*  
copper or brass galvanized.
- > *Diffuser:*  
opal white or glossy black blown glass.
  
- > *Deckenrosette:*  
weiß lackiert.
- > *Körper:*  
Kupfer oder Messing galvanisiert.
- > *Diffusor:*  
mundgeblasenes Glas, opalweiß  
oder schwarz glänzend.
  
- > *Rosette:*  
verni blanc mat.
- > *Corps:*  
galvanisé-laiton ou galvanisé-cuivre.
- > *Diffuseur:*  
verre blanc opalin ou verni noir brillant.
  
- > *Florón de techo:*  
barnizado blanco mate.
- > *Cuerpo:*  
galvanizado laton o galvanizado cobre.
- > *Difusor:*  
cristal blanco opal o barnizado  
negro brillante.

## Light data



 max 1x100W IAA E27

 max 1x20W FBA E27

## Model S3

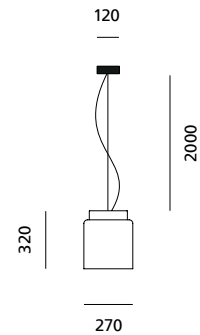

## Model S5

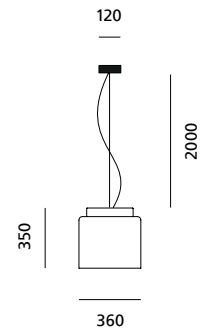

## Colors



brass / white



copper / black



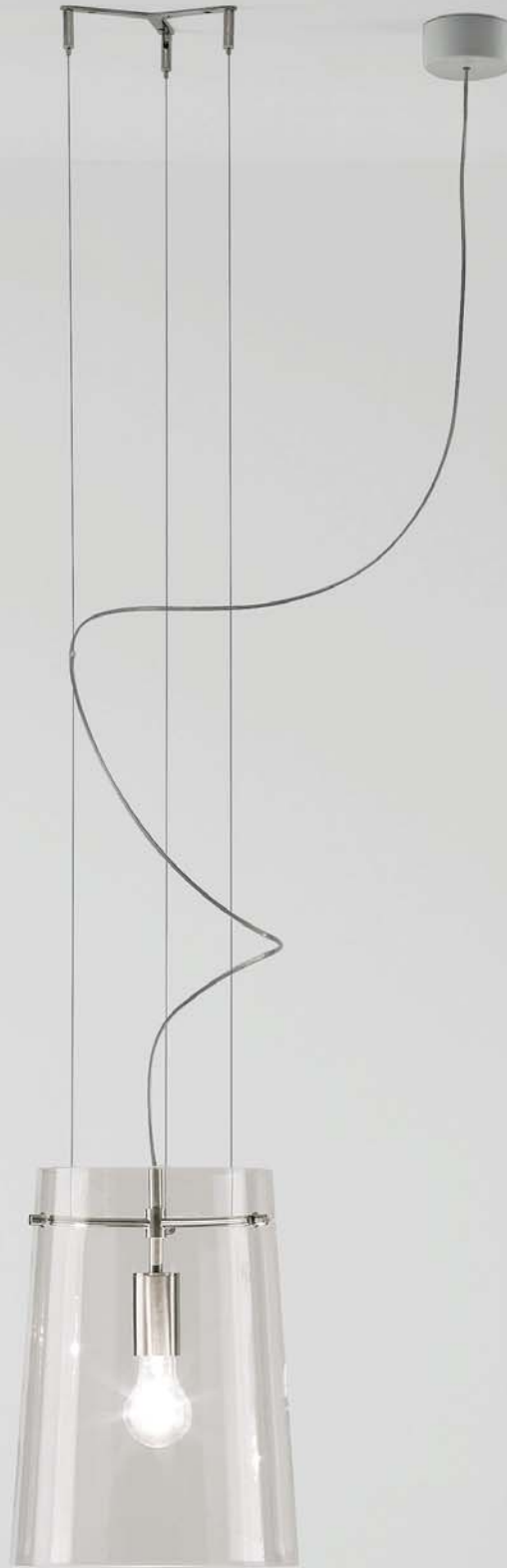

## Structure

---

- > *Rosone a soffitto:*  
verniciato bianco opaco.
- > *Diffusore:*  
vetro soffiato.
  
- > *Ceiling rose:*  
white painted.
- > *Diffuser:*  
blown glass.
  
- > *Deckenrosette:*  
weiß lackiert.
- > *Diffusor:*  
geblasenes Glas.
  
- > *Rosette:*  
verni blanc mat.
- > *Diffuseur:*  
verre soufflé.
  
- > *Florón de techo:*  
barnizado blanco mate.
- > *Difusor:*  
cristal soplado.

## Light data

---



- clear glass / max 1x150W IAA E27
- clear glass / max 1x150W IAA E27
- clear glass / max 1x100W HAGS/UB E27
- clear glass / max 1x150W IRR E27
- opal glass / max 1x150W IAA E27
- opal glass / max 1x23W FBG E27

## Colors

---

- crystal
- white
- mirror

## Model Small S1

---

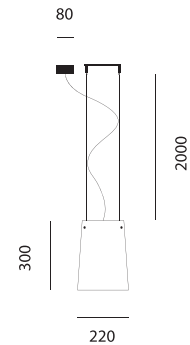

## Model S1

---

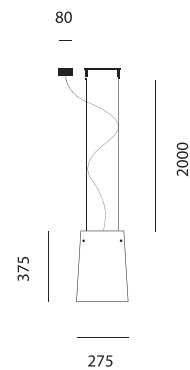

## Model S3

---

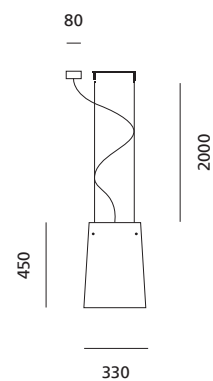



## Structure

- > **Rosone a soffitto:**  
verniciato bianco opaco.
- > **Corpo:**  
alluminio verniciato.
- > **Reattore:**  
elettronico, dimmerabile a richiesta.  
Versione LED, dimmerabile a richiesta.
- > **Ceiling rose:**  
matt white painted.
- > **Body:**  
painted aluminium.
- > **Ballast:**  
electronic, dimmable on request.  
LED version, dimmable on request.
- > **Deckenrosette:**  
matt weiß lackiert.
- > **Diffusor:**  
lackiertes Aluminium.
- > **Vorschaltgerät:**  
elektronisch, dimmbar auf Wunsch.  
Version LED, dimmbar auf Wunsch.
- > **Rosette:**  
verni blanc mat.
- > **Corps:**  
aluminium verni.
- > **Ballast:**  
électronique, réglable sur demande.  
Version LED, réglable sur demande.
- > **Florón de techo:**  
barnizado en blanco mate.
- > **Cuerpo:**  
aluminio barnizado.
- > **Reactór:**  
bobina de reacción con dimmer opcional.  
Version LED, regulable a petición.

## Light data



- ⇐ S1 / 1x24W FDH G5
- ⇐ S3 / 1x39W FDH G5
- ⇐ S5 / 1x54W FDH G5
- ⇐ S7 / 1x80W FDH G5

- \* LED S1 / LED 19,3W – 3000K (2800lm)
- \* LED S3 / LED 28,9W – 3000K (4200lm)
- \* LED S5 / LED 38,6W – 3000K (5600lm)
- \* LED S7 / LED 48,2W – 3000K (7000lm)

(\*) disponibile in altre versioni / other options available

## Model S1

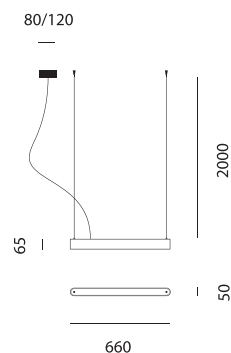

## Model S3

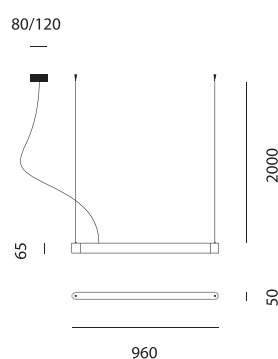

## Model S5

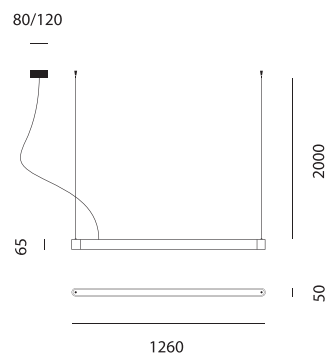

## Model S7

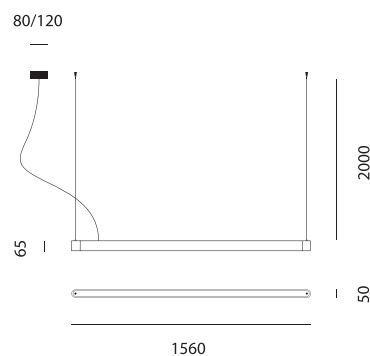

## Colors

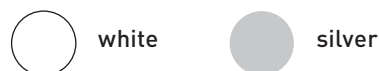





## Structure

- > **Struttura e diffusore:**  
metallo verniciato con elemento superiore in vetro stampato sabbiato.
- > **Cavo:**  
autoportante con rivestimento in tessuto rosso o nero.
- > **Structure and diffuser:**  
painted metal with upper element in sandblasted glass.
- > **Cable:**  
self-supporting, with covering in red or black fabric.
- > **Struktur und Deckenrosette:**  
lackiertes Metall mit oberer Kuppel aus Glas bedruckt sandgestrahlt.
- > **Kabel:**  
selbsttragendes Kabel mit Bezug aus Gewebe rot oder schwarz.
- > **Structure et rosette:**  
métal verni avec dôme en verre imprimé sablé.
- > **Câble:**  
autoportant avec revêtement en tissu rouge ou noir.
- > **Estructura y florón de techo:**  
metal barnizado con el elemento superior en vidrio arenado.
- > **Cable:**  
autoportante con cubre en tela roja o negra.

## Light data



☞ max 1x100W IAA E27

☞ max 1x20W FBA E27

## Model S1

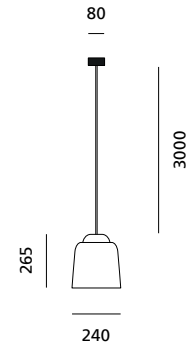

## Model S3

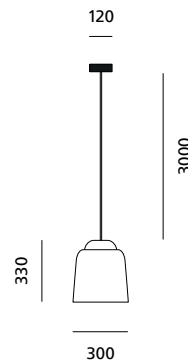

## Model S5

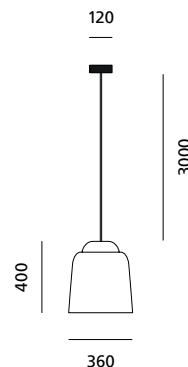

## Colors

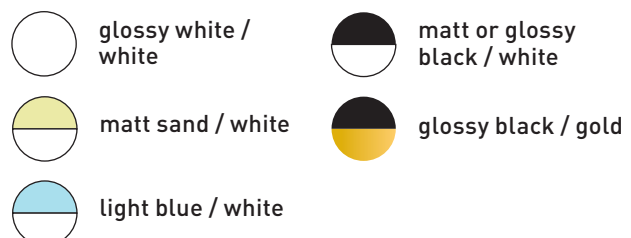



## Structure

- > **Corpo:**  
metallo verniciato nero lucido,  
azzurro o sabbia opaco.
- > **Diffusore:**  
vetro soffiato opalino bianco.
- > **Body:**  
painted glossy black, matt sand  
or light blue metal.
- > **Diffuser:**  
opal white blown glass.
- > **Körper:**  
Metall schwarz glänzend- oder sand matt-  
oder hellblau lackiert.
- > **Diffusor:**  
geblasenes Glas opalweiß.
- > **Corp:**  
métal verni noir brillant,  
sable mat ou bleu clair.
- > **Diffuseur:**  
verre opalin soufflé blanc.
- > **Cuerpo:**  
metal pintado negro brillante,  
beige-arena mate o azul mate.
- > **Difusor:**  
cristal soplado opalino blanco.

## Light data

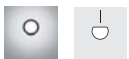

max 1x100W IAA E27

max 1x20W FBA E27

## Model S1

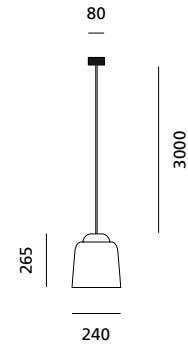

## Model S3

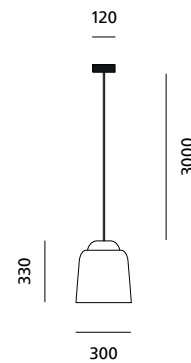

## Colors

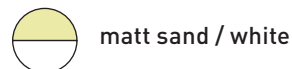
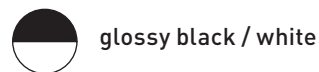

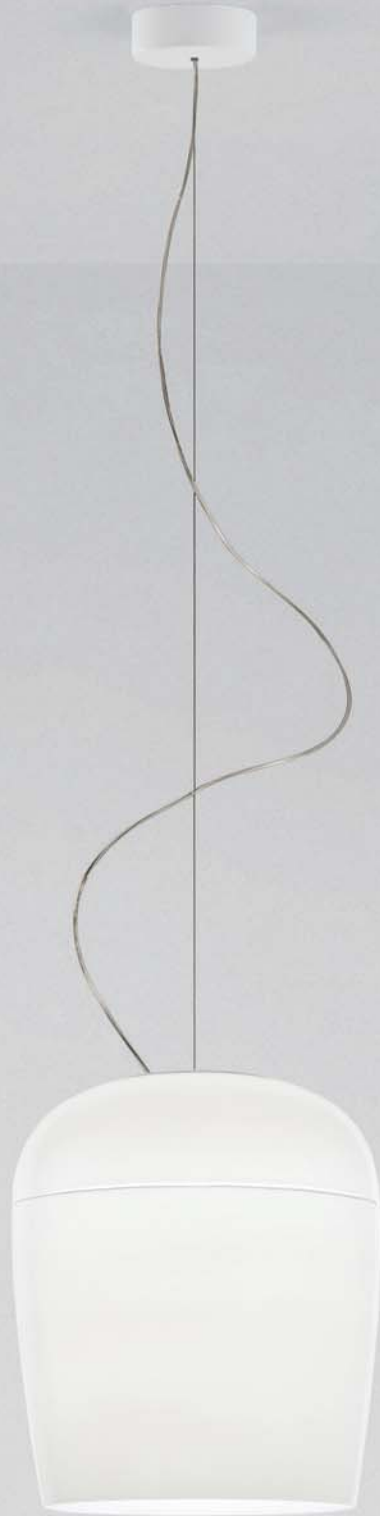

## Structure

- > **Struttura e rosone a soffitto:**  
verniciato bianco opaco.
- > **Diffusore:**  
vetro soffiato verniciato all'interno.
- > **Versione LED:**  
dimmerabile a richiesta.

- > **Structure and ceiling rose:**  
matt white painted.
- > **Diffuser:**  
blown glass painted on the inside.
- > **LED version:**  
dimmable on request.

- > **Struktur und Deckenrosette:**  
matt weiß lackiert.
- > **Diffusor:**  
geblasenes Glas innen lackiert.
- > **Version LED:**  
dimmbar auf Wunsch.

- > **Structure et rosette:**  
verni blanc mat.
- > **Diffuseur:**  
verre soufflé peinte intérieurement.
- > **Version LED:**  
réglable sur demande.

- > **Estructura y florón de techo:**  
barnizado blanco mate.
- > **Difusor:**  
vidrio soplado barnizado internamente.
- > **Version LED:**  
regulable a petición.

## Light data



S3.S5 / max 1x150W IAA E27

S3.S5 / max 1x100W HAGS/UB E27

S3.S5 / max 1x100W IRR E27

S3.S5 / max 1x23W FBT E27

\* LED S3.S5 / LED 9,6W – 3000K (1034lm)

(\*) disponibile in altre versioni / other options available

## Model S3

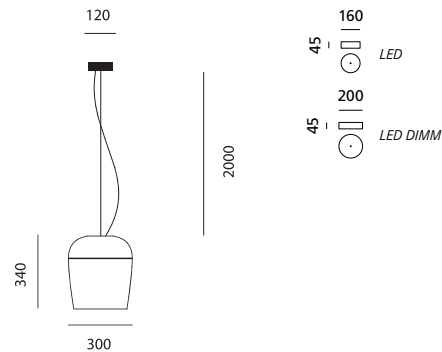

## Model S5

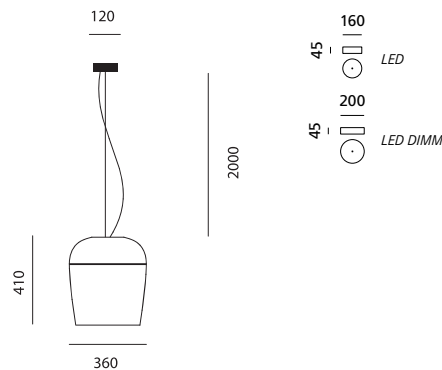

## Colors

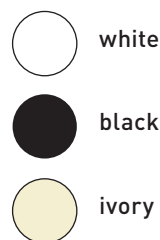



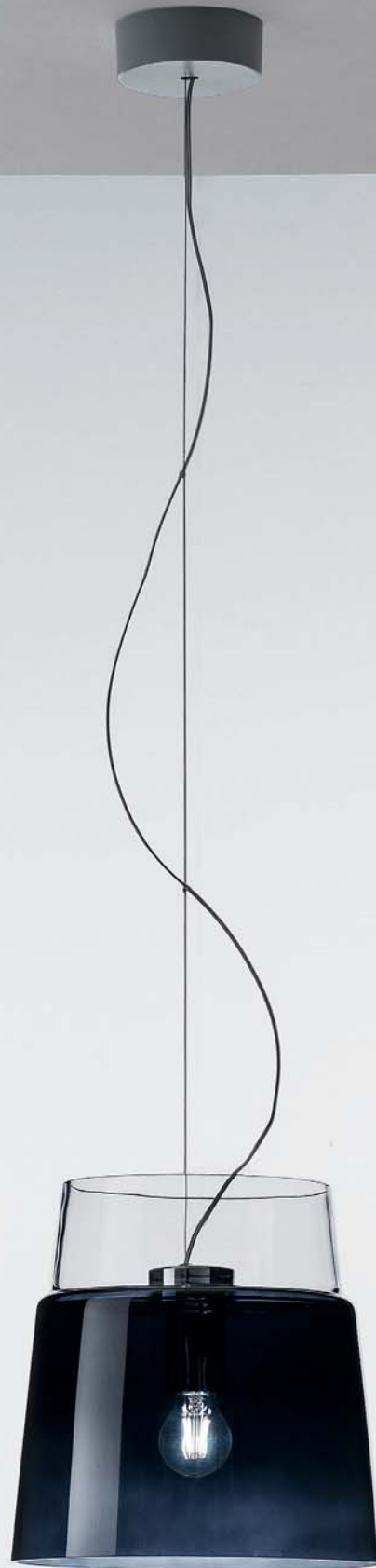

## Structure

---

- > **Struttura:**  
acciaio cromato.
- > **Diffusore:**  
vetro soffiato con decorazione bianca o fumé grigio sulla parte inferiore.
- > **Structure:**  
chromed steel.
- > **Diffuser:**  
blown glass with white or smoked grey decoration on the lower part.
- > **Struktur:**  
Stahl verchromt.
- > **Diffusor:**  
mundgeblasenes Glas mit unterem Teil weiß- oder rauchgrau lackiert.
- > **Structure:**  
acier chromé.
- > **Diffuseur:**  
verre soufflé avec partie inférieure vernie blanc ou gris fumé.
- > **Estructura:**  
acero cromado.
- > **Difusor:**  
vidrio soplado con parte inferior pintada blanca o gris ahumado.

## Light data

---



☞ max 1x60W IAA E27

☞ max 1x10W DRAA/C E27 (LED)

## Model S3

---

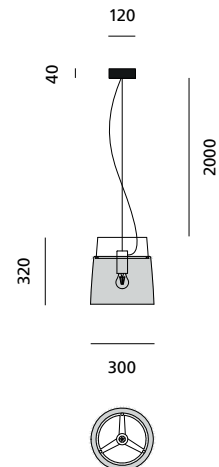

## Colors

---



crystal / white



crystal / smoked grey



## Structure

---

- > *Rosone a soffitto:*  
verniciato bianco opaco.
- > *Diffusore:*  
vetro soffiato opalino satinato bianco.
  
- > *Ceiling rosette:*  
matt white painted.
- > *Diffuser:*  
satin white opal blown glass.
  
- > *Deckenrosette:*  
matt weiß lackiert.
- > *Diffusor:*  
geblasenes Glas opalweiß.
  
- > *Rosette:*  
verni blanc mat.
- > *Diffuseur:*  
verre opalin soufflé satiné blanc.
  
- > *Florón de techo:*  
barnizado blanco mate.
- > *Difusor:*  
cristal soplado opalino satinado blanco.

## Light data

---



 S1G9 / max 1x75W HSGST G9

## Model S1G9

---

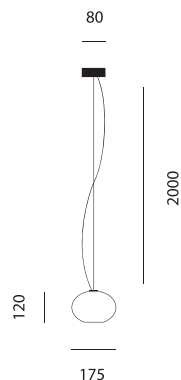

## Colors

---



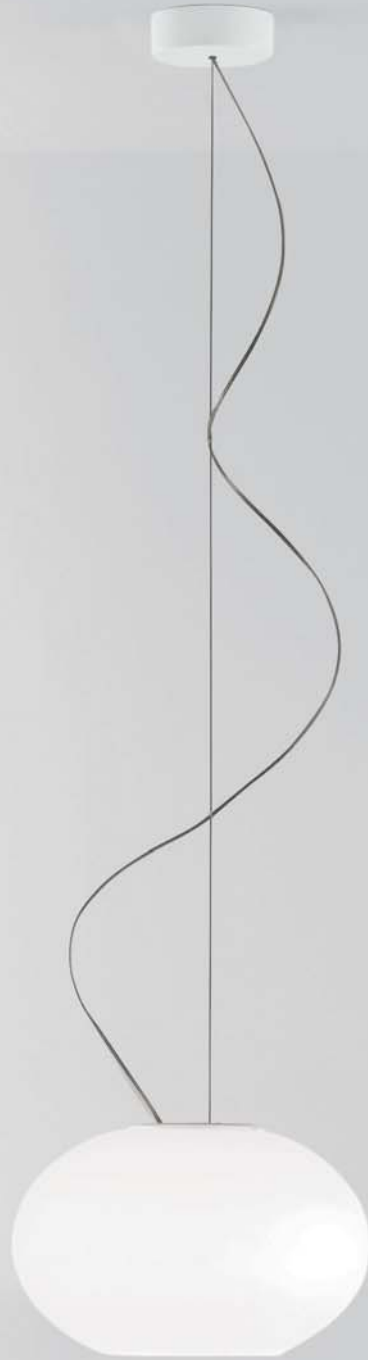



# ZERO S3.S5.S7 Mengotti / Prandina - 1994

## Structure

- > *Rosone a soffitto:*  
verniciato bianco opaco.
- > *Diffusore:*  
vetro soffiato opalino satinato bianco.
- > *Versione LED:*  
dimmerabile a richiesta.

- > *Ceiling rosette:*  
matt white painted.
- > *Diffuser:*  
satin white opal blown glass.
- > *LED version:*  
dimmable on request.

- > *Deckenrosette:*  
matt weiß lackiert.
- > *Diffusor:*  
geblasenes Glas opalweiß.
- > *Version LED:*  
dimmbar auf Wunsch.

- > *Rosette:*  
verni blanc mat.
- > *Diffuseur:*  
verre opalin soufflé satiné blanc.
- > *Version LED:*  
réglable sur demande.
- > *Florón de techo:*  
barnizado blanco mate.
- > *Difusor:*  
cristal soplado opalino satinado blanco.
- > *Version LED:*  
regulable a petición.

## Light data

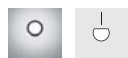

max 1x150W IAA E27

max 1x150W HSGST E27

1x23W FBT E27

\* LED S3 / LED 9,6W – 3000K (1034lm)

\* LED S5 / LED 9,6W – 3000K (1034lm)

\* LED S7 / LED 9,6W – 3000K (1034lm)

(\*) disponibile in altre versioni /  
other options available

## Model S3

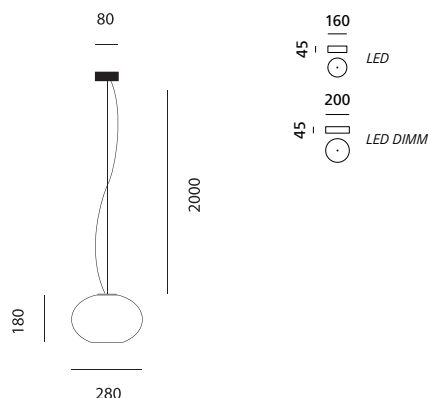

## Model S5

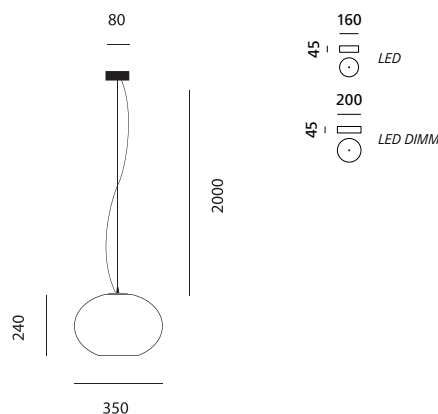

## Model S7

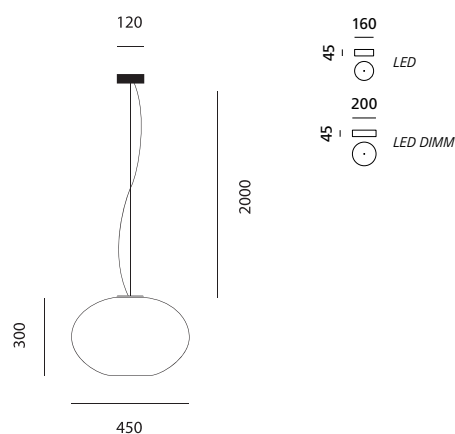

## Colors





## Structure

- > **Rosone a soffitto:**  
verniciato bianco opaco.
- > **Diffusore:**  
vetro soffiato bianco satinato.
- > **Versione LED:**  
dimmerabile a richiesta.
  
- > **Ceiling rose:**  
matt white painted.
- > **Diffuser:**  
opal white blown glass diffuser.
- > **LED version:**  
dimnable on request.
  
- > **Deckenrosette:**  
matt weiß lackiert.
- > **Diffusor:**  
geblasenes Glas satiniert.
- > **Version LED:**  
dimmbar auf Wunsch.
  
- > **Rosette:**  
verni blanc mat.
- > **Diffuseur:**  
verre soufflé blanc opalin.
- > **Version LED:**  
réglable sur demande.
  
- > **Florón de techo:**  
barnizado blanco mate.
- > **Difusor:**  
vidrio soplado blanco satinado.
- > **Version LED:**  
regulable a petición.

## Light data



☞ S5 / 1x23W FBT E27

☞ S7 / 1x30W FBT E27

\* LED S5 / LED 9,6W – 3000K (1034lm)

\* LED S7 / LED 9,6W – 3000K (1034lm)

(\*) disponibile in altre versioni / other options available

## Model S5

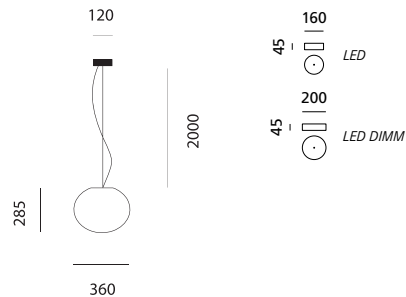

## Model S7

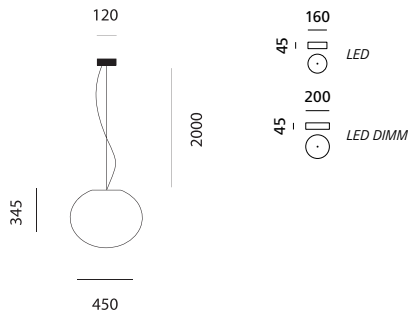

## Colors











# ABC T1.T3 Sandro Santantonio Design - 2007

## Structure

- > **Struttura:**  
metallo cromato o verniciato bianco opaco.
- > **Diffusore:**  
cristallo con incisioni in sabbiatura.  
Filtro interno in vetro pyrex su richiesta.
- > **Reattore:**  
regolabile con dimmer incluso.

- > **Structure:**  
chrome or matt white painted metal.
- > **Diffuser:**  
crystal with sandblasted engravings.  
Internal screen in Pyrex glass (on request).
- > **Ballast:**  
dimmer included.

- > **Struktur:**  
verchromt oder matt weiß lackiert
- > **Diffusor:**  
Kristall mit sandgestrahlter Gravur.  
Innenfilter aus opalweißem Pyrex-Glas  
(auf Wunsch).
- > **Vorschaltgerät:**  
regelbar, dimmer inbegriffen.

- > **Structure:**  
métal chromé ou verni blanc opaque.
- > **Diffuseur:**  
cristal avec gravure sablée.  
Filtre intérieur en pyrex blanc (à la demande).
- > **Ballast:**  
réglable avec variateur compris.

- > **Estructura:**  
metal cromado o barnizado blanco opaco.
- > **Difusor:**  
cristal con incisiones arenadas.  
Filtro interno en vidrio pyrex opcional.
- > **Reactór:**  
regulable con dimmer incluido.

## Light data



- T1 / max 1x100W IAA E27
- T1 / max 1x100W HSGST E27
- T3 / max 1x150W IAA E27
- T3 / max 1x150W HSGST E27
- T1 mm 1950
- T3 mm 2470

## Model T1



## Model T3

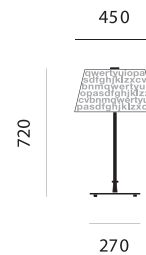

## Colors

- white
- crystal
- black crystal



## Structure

- > **Struttura:**  
metallo cromato o nichelato spazzolato.
- > **Diffusore:**  
vetro soffiato.
- > **Structure:**  
chrome or brushed nickel metal.
- > **Diffuser:**  
blown glass.
- > **Struktur:**  
Metall verchromt oder nickel gebürstet.
- > **Diffusor:**  
geblasenes glas.
- > **Structure:**  
métal chromé ou nickel brossé.
- > **Diffuseur:**  
verre soufflé.
- > **Estructura:**  
metal cromado o niquel cepillado.
- > **Difusor:**  
cristal soplado.

## Light data



- T1.T3 / max 1x150W IAG E27
- T1.T3 clear glass / max 1x150W IAA E27
- T1.T3 clear glass / max 1x150W IRR E27
- T1.T3 opal glass / max 1x150W IAA E27
- T1.T3 opal glass / max 1x23W FBG E27
- small T1 / max 1x100W IAG E27
- small T1 / max 1x100W IAA E27
- small T1 / max 1x23W FBG E27

— □ mm 1950

## Model small T1

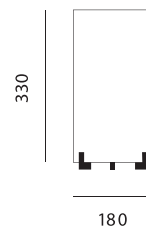

## Colors small T1



white

## Model T1

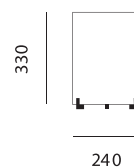

## Model T3

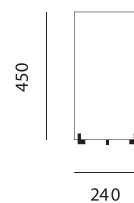

## Colors T1.T3



white



crystal





## Structure

---

- > **Struttura:**  
metallo cromato o nichelato spazzolato.
- > **Diffusore:**  
vetro soffiato. Disco superiore in vetro opalino satinato bianco.
- > **Reattore:**  
regolabile con dimmer incluso.

- > **Structure:**  
chrome or brushed nickel metal.
- > **Diffuser:**  
blown glass. Satin white opal upper plate glass diffuser.
- > **Ballast:**  
dimmer included.

- > **Struktur:**  
Metall verchromt oder Nickel gebürstet.
- > **Diffusor:**  
geblasenes Glas. Oberer Glasschirm weiß Satiniert.
- > **Vorschaltgerät:**  
regelbar, dimmer inbegriffen.

- > **Structure:**  
métal chromé ou nickel brossé.
- > **Diffuseur:**  
verre soufflé. Disque supérieur en verre opalin satiné blanc.
- > **Ballast:**  
réglable avec variateur compris.

- > **Estructura:**  
metal cromado o niquel cepillado.
- > **Difusor:**  
cristal soplado. Disco superior en cristal opalino satinado blanco.
- > **Reactór:**  
regulable con dimmer incluido.

## Light data

---



 max 1x100W IAA E27

 max 1x150W HSGST E27

 mm 2070

## Model T30

---

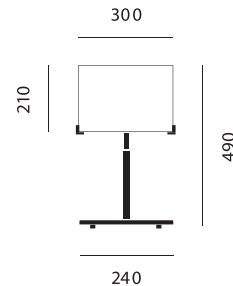

## Colors

---





## Structure

---

- > **Struttura:**  
metallo piegato verniciato nei colori opachi bianco, nero, giallo e azzurro.
- > **Reattore:**  
interruttore on/off e convertitore a spina.
- > **Structure:**  
folded metal painted in white, black, yellow and blue.
- > **Ballast:**  
plug converter and on/off switch.
- > **Struktur:**  
schwarz, weiß, gelb und blau lackiertem gefaltet Metall.
- > **Vorschaltgerät:**  
schalter Transformator und on/off Kabel Schalter.
- > **Structure:**  
métal courbé, verni noir, blanc, jaune et bleu.
- > **Ballast:**  
fiche Transformateur et on/off câble interrupteur.
- > **Estructura:**  
metal doblado barnizado negro, blanco, amarillo y azul.
- > **Reactór:**  
enchufe con transformador y interruptor on/off en el cable.

## Model T1

---

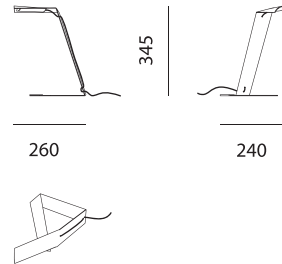

## Colors

---

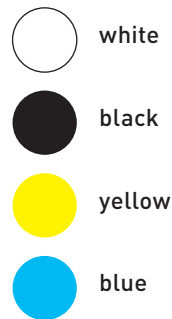

## Light data

---



LED 1x2,5W - 3100K (205lm)

mm 1950



Structure

- > *Struttura:*  
acciaio verniciato bianco.
- > *Diffusore:*  
polietilene rotazionale bianco opalino.
- > *Schermo:*  
acciaio verniciato bianco.
  
- > *Structure:*  
white painted steel.
- > *Diffuser:*  
opal white roto-moulded polyethylene.
- > *Shade:*  
white painted steel.
  
- > *Struktur:*  
weiß lackiertes Stahl.
- > *Diffusor:*  
Polyethylen hergestellt  
im Rotationsspritzgussverfahren.
- > *Schirm:*  
weiß lackiertes Stahl.
  
- > *Structure:*  
acier verni blanc.
- > *Diffuseur:*  
polyéthylène roto blanc opalin.
- > *Écran:*  
acier blanc brillant.
  
- > *Estructura:*  
acero barnizado blanco.
- > *Difusor:*  
polietileno rotacional opalino blanco.
- > *Pantalla:*  
acero blanco brillante.

Light data



☞ max 1x15W FBA E27

— mm 2000

Model T1

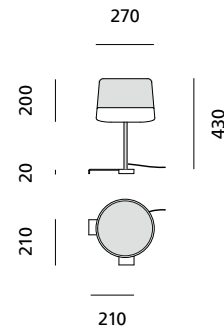

Model T10

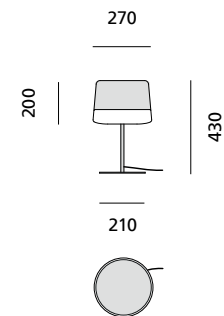

Colors







# GINGER T30.T50 Azzolin / Prandina R&D - 2009

## Structure

---

- > **Struttura:**  
metallo verniciato bianco opaco.
- > **Diffusore:**  
polietilene rotazionale bianco.
- > **Disco inferiore:**  
metacrilato opalino bianco.

- > **Structure:**  
matt white painted metal.
- > **Diffuser:**  
white roto-moulded polyethylene.
- > **Lower plate:**  
opal white methacrylate.

- > **Struktur:**  
Metall matt weiß lackiert
- > **Diffusor:**  
Polyethylen hergestellt  
im Rotations-spritzgussverfahren.
- > **Unterer Scheibe:**  
opalweiß Methacrylat.

- > **Structure:**  
métal verni blanc mat.
- > **Diffuseur:**  
polyéthylène roto blanc opalin.
- > **Disque inférieur:**  
méthacrylate blanc.

- > **Estructura:**  
metal barnizado en blanco mate.
- > **Difusor:**  
polietileno rotacional opalino blanco.
- > **Disco inferior:**  
metacrilato opalino blanco.

## Light data

---



 max 2x15W FBA E27

 T30 mm 1870

 T50 mm 2500

## Model T30

---

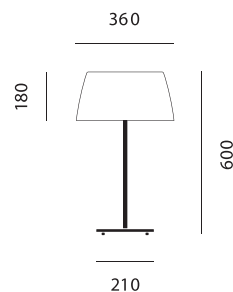

## Model T50

---

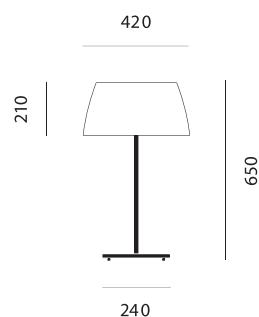

## Colors

---



white



## Structure

> **Diffusore:**  
vetro soffiato.

> **Base:**  
cristallo trasparente. Montatura portalampada in metallo cromato opaco con filtro in pyrex.

> **Diffuser:**  
blown glass.

> **Base:**  
crystal glass. Chrome metal lamp holder with Pyrex filter.

> **Diffusor:**  
mundgeblasenes Glas.

> **Basis:**  
geblasenes Kristall Glas. Lampenfassung aus verchromtem Metall mit Pyrex-Glas.

> **Diffuseur:**  
verre soufflé.

> **Base:**  
verre soufflé cristal transparent. Monture porte lampe en métal chromé avec filtre pyrex.

> **Difusor:**  
cristal soplado.

> **Base:**  
cristal transparente. Portalámpara en metal cromado opaco con filtro en pyrex.

## Light data



⇒ T1 / max 1x40W HSGST G9

⇒ T3 / max 1x60W HSGST G9

┌──────────┐ □ T1 mm 1840

┌──────────┐ □ T3 mm 1785

## Model T1

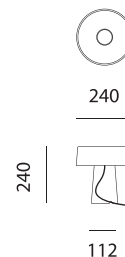

## Model T3

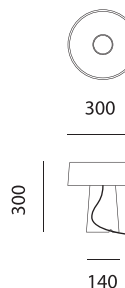

## Colors



white / crystal



red / crystal





## Structure

- > **Diffusore:**  
vetro soffiato.
- > **Base:**  
cristallo trasparente.
- > **Struttura:**  
metallo verniciato bianco. Cavo di alimentazione con dimmer incorporato rivestito in poliester di colore rosso.
  
- > **Diffuser:**  
blown glass.
- > **Base:**  
transparent crystal.
- > **Structure:**  
matt-white painted metal. Red polyester-covered feeding wire with built-in dimmer.
  
- > **Diffuser:**  
mundgeblasenes Glas.
- > **Basis:**  
kristallklar.
- > **Struktur:**  
Lampenfassung aus weiß lackiertem Metall. Speisekabel mit eingebautem Dimmer mit rotem Polyester verkleidet.
  
- > **Diffuseur:**  
verre soufflé.
- > **Base:**  
cristal transparent.
- > **Structure:**  
métal peint blanc. Câble d'alimentation avec variateur incorporé revêtu en polyester rouge.
  
- > **Difusor:**  
cristal soplado.
- > **Base:**  
cristal transparente.
- > **Estructura:**  
metal barnizado blanco. Cable de alimentación con dimmer incluido con revestimiento en poliéster de color rojo.

## Light data



⇒ T1 / max 3x40W HSGST G9

⇒ T3 / max 3x60W HSGST G9

┌──────────┐ □ T1 mm 2200

┌──────────┐ □ T3 mm 2100



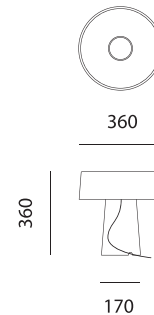

## Model T1

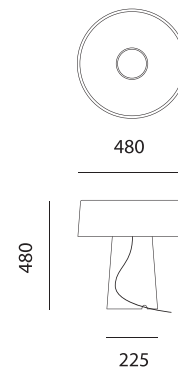

## Model T3



## Colors

-  white / crystal
-  red / crystal
-  black / crystal
-  mirror / crystal



## Structure

- > **Struttura:**  
corpo lampada in metallo bianco o nero.
- > **Diffusore:**  
vetro soffiato trasparente decorato.
- > **Structure:**  
white or black metal lamp structure.
- > **Diffuser:**  
blown transparent decorated glass.
- > **Struktur:**  
Metall weiß oder schwarz.
- > **Diffusor:**  
mundgeblasenes durchscheinendes Glas, lackiert.
- > **Structure:**  
métal verni blanc ou noir.
- > **Diffuseur:**  
verre soufflé transparent, verni.
- > **Estructura:**  
metal blanco o negro.
- > **Difusor:**  
vidrio soplado transparente, pintado.

## Light data



- ⚡ T1 / max 1x40W HSGST G9
- 💡 T3 / max 1x60W IAA E27
- 💡 T3 / max 1x20W FBA E27

- ┌───┐ T1 / mm 2100
- ┌───┐ T3 / mm 2000

## Model T1

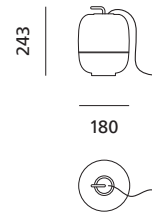

## Colors T1

-  white
-  silver metallized transmirror
-  copper metallized transmirror
-  gold leaf

## Model T3

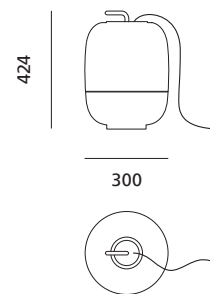

## Colors T3

-  white
-  metallized silver
-  metallized copper
-  gold leaf



## Structure

- > **Struttura:**  
verniciata bianco o nero opaco.
- > **Diffusore inferiore:**  
metacrilato opalino.
- > **Reattore:**  
regolabile con dimmer incluso.

- > **Structure:**  
matt white or black painted.
- > **Lower diffuser:**  
opal methacrylate.
- > **Ballast:**  
dimmer included.

- > **Struktur:**  
weiß matt oder schwarz lackiert.
- > **Unterer Diffusor:**  
Methacrylat opal.
- > **Vorschaltgerät:**  
regelbar, dimmer inbegriffen.

- > **Structure:**  
verni blanc mat ou noir mat.
- > **Diffuseur inferieur:**  
méthacrylate opal.
- > **Ballast:**  
réglable avec variateur compris.

- > **Estructura:**  
pintada blanco mate o negro mate.
- > **Difusor inferior:**  
metacrilato opalino.
- > **Reactór:**  
regulable con dimmer incluido.

## Light data



\* LED 1x25W - 2700K (2300lm)

(\*) disponibile in altre versioni / other options available

— □ mm 2100

## Model T3

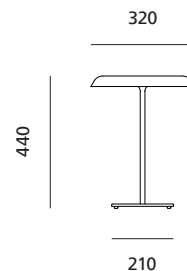

## Colors

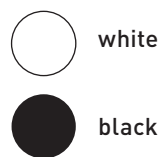





## Structure

---

- > **Struttura:**  
corpo lampada in metallo bianco.
- > **Diffusore:**  
vetro soffiato opalino bianco satinato.

- > **Structure:**  
white metal lamp structure.
- > **Diffuser:**  
satin white opal blown glass.

- > **Struktur:**  
Metall weiß.
- > **Diffusor:**  
mundgeblasenes Glas opalweiß.

- > **Structure:**  
métal blanc.
- > **Diffuseur:**  
verre soufflé blanc opalin.

- > **Estructura:**  
metal blanco.
- > **Difusor:**  
vidrio soplado blanco opal.

## Light data

---



max 1x60W IAA E27

mm 2000

## Model T1

---

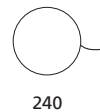

240



220

190

## Model T3

---

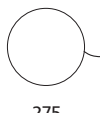

275



257

216

## Colors

---





## Structure

---

> **Struttura:**  
alluminio curvato, verniciato nero opaco.  
Testa LED orientabile in alluminio anodizzato  
e ottica in PMMA. Braccio con rotazione a 360°.

> **Versione LED:**  
dimmerabile a richiesta.

> **Structure:**  
bent aluminium painted in matt black.  
LED tilting head with PMMA optic lens,  
in anodized aluminium. 360° revolving structure.

> **LED version:**  
dimnable on request.

> **Struktur:**  
verbogen Aluminium matt schwarz lackiert  
Verstellbarer LED-Kopf aus eloxiertes  
Aluminium und Optik aus Methacrylat.  
Lampenkörper um 360° schwenkbar.

> **Version LED:**  
dimmbar auf Wunsch.

> **Structure:**  
aluminium courbé, verni noir mat. Tête LED  
orientable en aluminium anodisé et optique  
en methacrylate. Diffuseur orientable à 360°.

> **Version LED:**  
réglable sur demande.

> **Estructura:**  
aluminio curvado barnizado negro mate.  
Cabeza LED orientable en aluminio anodizado  
y lente en metacrilato. Cuerpo de la lámpara  
con rotación de 360°.

> **Version LED:**  
regulable a petición.

## Model T3

---

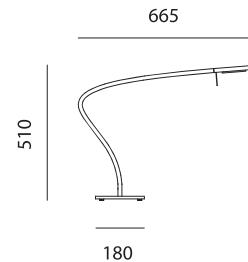

## Colors

---



## Light data

---

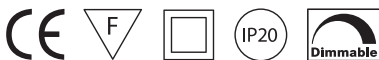

LED 1x6W - 3000K (340lm)

— mm 1900





## Structure

---

- > **Struttura:**  
metallo cromato o nichelato spazzolato.
- > **Diffusore:**  
vetro soffiato.
- > **Reattore:**  
regolabile con dimmer incluso.
  
- > **Structure:**  
chrome or brushed nickel metal.
- > **Diffuser:**  
blown glass.
- > **Ballast:**  
dimmer included.

- > **Struktur:**  
Metall verchromt oder Nickel gebürstet.
- > **Diffuser:**  
geblasenes Glas.
- > **Vorschaltgerät:**  
regelbar, dimmer inbegriffen.
  
- > **Structure:**  
métal chromé ou nickel brossé.
- > **Diffuseur:**  
verre soufflé.
- > **Ballast:**  
réglable avec variateur compris.

- > **Estructura:**  
metal cromado o niquel cepillado.
- > **Difusor:**  
cristal soplado.
- > **Reactór:**  
regulable con dimmer incluido.

## Light data

---



 max 1x150W HSGST E27

 max 1x150W IAA E27

 Small T1 / mm 2040

 T1 / mm 1960

## Model Small T1

---

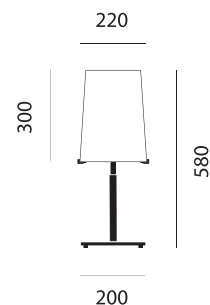

## Model T1

---

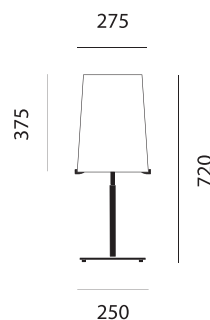

## Colors

---



white



mirror



## Structure

- > **Struttura:**  
acciaio cromato.
- > **Diffusore:**  
vetro soffiato con decorazione bianca o fumé grigio sulla parte superiore.
- > **Cavo:**  
rivestito in poliestere di colore grigio chiaro.

- > **Structure:**  
chromed steel.
- > **Diffuser:**  
blown glass with white or smoked grey decoration on the upper part.
- > **Cable:**  
light grey polyester-covered feeding wire.

- > **Struktur:**  
Stahl verchromt.
- > **Diffusor:**  
mundgeblasenes Glas mit oberem Teil weiß- oder rauchgrau lackiert.
- > **Kabel:**  
mit Bezug aus Polyester hellgrau.

- > **Structure:**  
acier chromé.
- > **Diffuseur:**  
verre soufflé avec partie supérieure vernie blanc ou gris fumé.
- > **Câble:**  
avec revêtement en polyester gris clair.

- > **Estructura:**  
acero cromado.
- > **Difusor:**  
vidrio soplado con parte superior pintada blanca o gris ahumado.
- > **Cable:**  
revestido de poliéster gris claro.

## Light data



max 1x60W IAA E27

mm 2500

## Model T3

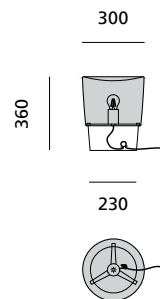

## Colors

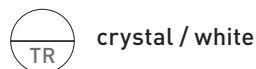







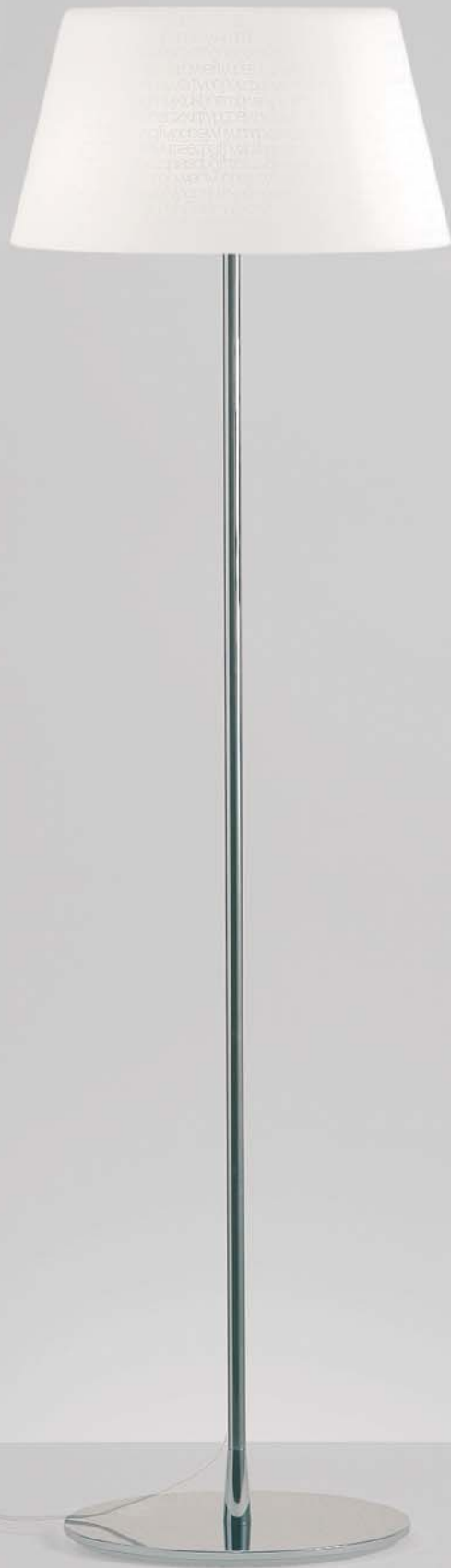

## Structure

- > **Struttura:**  
metallo cromato o verniciato bianco opaco.
- > **Diffusore:**  
cristallo con incisioni in sabbiatura.  
Filtro interno in vetro pyrex su richiesta.
- > **Reattore:**  
regolabile con dimmer incluso.
- > **Structure:**  
chrome or matt white painted metal.
- > **Diffuser:**  
crystal with sandblasted engravings.  
Internal screen in Pyrex glass (on request).
- > **Ballast:**  
dimmer included.

- > **Struktur:**  
Metall verchromt oder matt weiß lackiert.
- > **Diffusor:**  
Kristall mit sandgestrahlter Gravur.  
Innenfilter aus Pyrex-Glas (auf Wunsch).
- > **Vorschaltgerät:**  
regelbar, dimmer inbegriffen.
- > **Structure:**  
métal chromé ou verni blanc opaque.
- > **Diffuseur:**  
cristal avec gravure sablée.  
Filtre intérieur en pyrex blanc (à la demande).
- > **Ballast:**  
réglable avec variateur compris.

- > **Estructura:**  
metal cromado o barnizado blanco opaco.
- > **Difusor:**  
cristal con incisiones arenadas.  
Filtro interno en vidrio pyrex opcional.
- > **Reactór:**  
regulable con dimmer incluido.

## Light data



⚡ F3.F5 / max 1x150W IAA E27

⚡ F3.F5 / max 1x250W HSGST E27

— □ F3 mm 2870

— □ F5 mm 2710

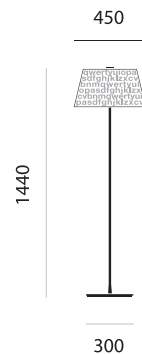

## Model F3

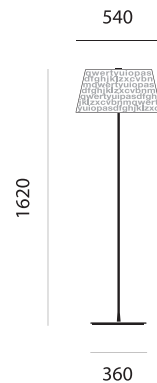

## Model F5



## Colors

-  white
-  crystal
-  black crystal



## Structure

- > **Guscio esterno:**  
metallo (F5) o polipropilene rotazionale verniciati.
- > **Diffusore inferiore:**  
metacrilato opalino bianco termoformato.
- > **Reattore:**  
elettronico, dimmerabile a richiesta (ECO F7).  
Anello di appoggio in metacrilato trasparente.  
Dimmer a pulsante o interruttore incorporato sul cavo.
  
- > **Outer diffuser:**  
painted metal (F5) or polypropylene.
- > **Lower diffuser:**  
opal white thermoformed methacrylate.
- > **Ballast:**  
electronic, dimmable on request (ECO F7).  
Transparent methacrylate support ring.  
Switch or foot control dimmer on power cord.
  
- > **Äußeres Gehäuse:**  
Polypropylen oder Metall lackiert (F5).
- > **Innere Reflektorschale:**  
wärmegeformtes Methacrylat matt weiß .
- > **Vorschaltgerät:**  
elektronisch, dimmbar auf Wunsch (ECO F7).  
Auflagering aus transparentem Methacrylat  
Schalter oder Schnur-Zwischen-Dimmer.
  
- > **Diffuseur extérieur:**  
métal (F5) ou polypropylène verni.
- > **Réflecteur intérieur:**  
méthacrylate thermoformé blanc.
- > **Ballast:**  
électronique, réglable sur demande (ECO F7).  
Anneau d'appui en méthacrylate transparent.  
Interrupteur ou variateur sur câble.
  
- > **Difusor externo:**  
metal (F5) o polipropileno rotacional barnizados.
- > **Difusor inferior:**  
metacrilato opalino blanco termoformato.
- > **Reactór:**  
bobina de reacción con dimmer opcional (ECO F7). Anillo de apoyo en metacrilato transparente.  
Cable con interruptor o dimmer.

## Model F5

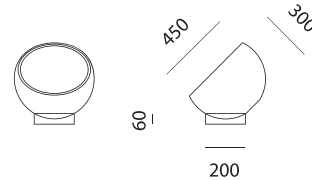



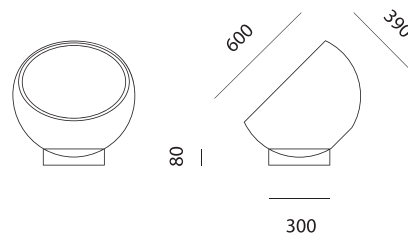

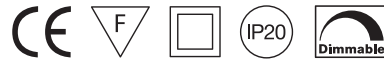

## Model F7



## Light data



-  F5 / 3x20W FBA E27
-  F5 / 3x40W IAA E27
-  F5 / 3x42W HSGSA E27
-  eco F7 / 1x55W FSC 2GX13
-  F5 / mm 2700
-  F7 / mm 2500

## Colors

-  glossy white
-  matt sand
-  matt or glossy black

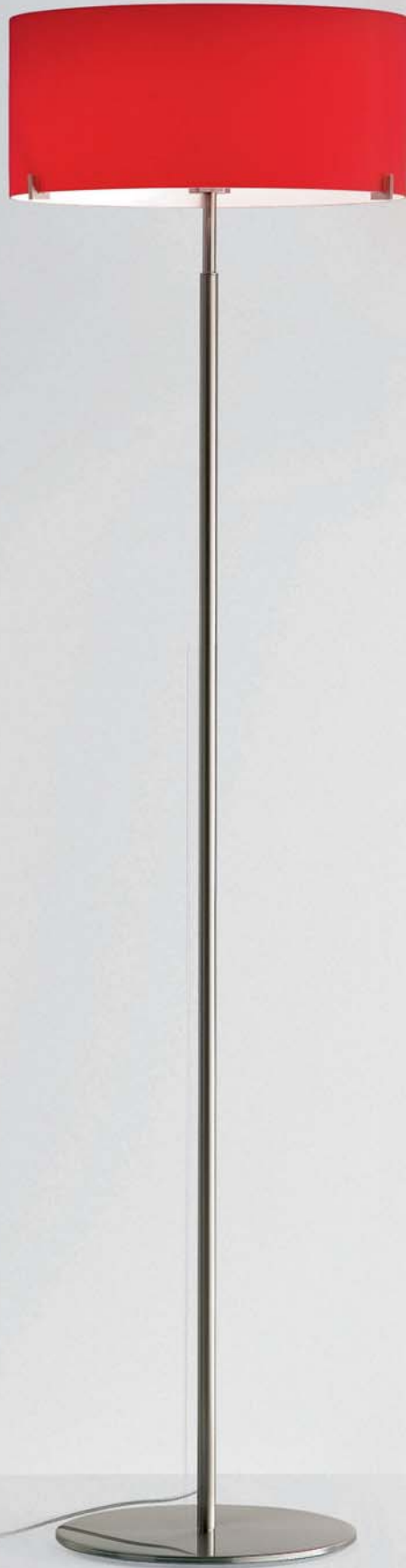



**Structure**

- > **Struttura:**  
metallo cromato o nichelato spazzolato.
- > **Diffusore:**  
vetro soffiato.
- > **Reattore:**  
regolabile con dimmer incluso.

- > **Structure:**  
chrome or brushed nickel metal.
- > **Diffuser:**  
blown glass.
- > **Ballast:**  
dimmer included.

- > **Struktur:**  
Metall verchromt oder Nickel gebürstet.
- > **Diffusor:**  
geblasenes Glas.
- > **Vorschaltgerät:**  
regelbar, dimmer inbegriffen.

- > **Structure:**  
métal chromé ou nickel brossé.
- > **Diffuseur:**  
verre soufflé.
- > **Ballast:**  
réglable avec variateur compris.

- > **Estructura:**  
metal cromado o niquel cepillado.
- > **Difusor:**  
cristal soplado.
- > **Reactór:**  
regulable con dimmer incluido.

**Light data**



- F1 / max 1x150W IAG E27
- F1 clear glass / max 1x150W IAA E27
- F1 opal glass / max 1x150W IAA E27
- F1 opal glass / max 1x250W HSGST E27
- F7 / 3x60W IAA E27
- F1 / mm 2690
- F7 / mm 2410

**Model F1**

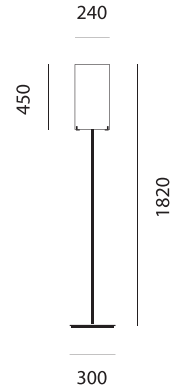

**Colors F1**

- white
- crystal

**Model F7**

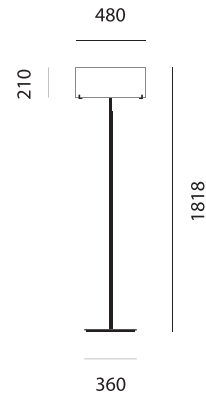

**Colors F7**

- white
- mirror
- red
- copper



## Structure

- > **Struttura:**  
alluminio e acciaio verniciati.
- > **Diffusore:**  
metacrilato bianco opalino. Regolabile in altezza. Paralume in tessuto bianco o nero disponibile su richiesta.
- > **Reattore:**  
regolabile con dimmer incluso.
  
- > **Structure:**  
painted aluminium and steel.
- > **Diffuser:**  
opal white methacrylate. Height adjustable. White or black fabric lampshade available upon request.
- > **Ballast:**  
dimmer included.
  
- > **Struktur:**  
Aluminium lackiert und Stahl.
- > **Diffusor:**  
opalweiß Methacrylat. Höhenverstellbar. Leuchtstoffschirm weiß oder schwarz, auf Wunsch.
- > **Vorschaltgerät:**  
regelbar, dimmer inbegriffen.
  
- > **Structure:**  
acier et aluminium verni blanc.
- > **Diffuseur:**  
méthacrylate blanc opalin. Règlable en hauteur. Diffuseur en tissu blanc ou noir, sur demande.
- > **Ballast:**  
réglable avec variateur compris.
  
- > **Estructura:**  
acero y aluminio pintado.
- > **Difusor:**  
metacrilato opalino blanco. Ajustable en altura. Difusor en tejido blanco o negro, a petición.
- > **Reactór:**  
regulable con dimmer incluido.

## Light data



\* LED 15W - 2700K (2400lm)

mm 2800

(\*) disponibile in altre versioni / other options available

## Model F5

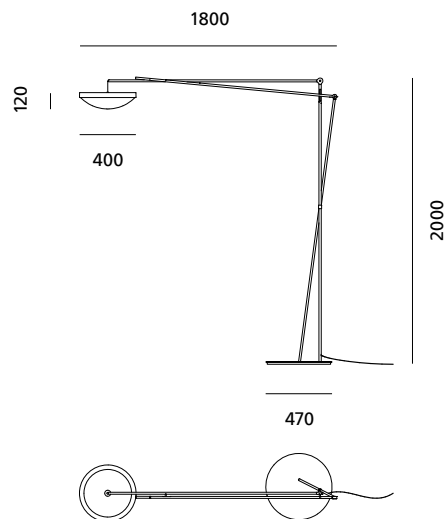

## Lampshade

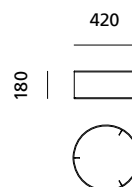

## Colors



**EFFIMERA F50**



## Structure

- > **Struttura:**  
alluminio e acciaio verniciati.
- > **Diffusore:**  
metacrilato bianco opalino.  
Regolabile in altezza.
- > **Paralume:**  
tessuto bianco o nero.
- > **Reattore:**  
regolabile con dimmer incluso.
  
- > **Structure:**  
painted aluminium and steel.
- > **Diffuser:**  
opal white methacrylate. Height adjustable.
- > **Lampshade:**  
white or black fabric.
- > **Ballast:**  
dimmer included.
  
- > **Struktur:**  
Aluminium lackiert und Stahl.
- > **Diffusor:**  
opalweiß Methacrylat. Höhenverstellbar.
- > **Leuchtstoffschirm:**  
weiß oder schwarz.
- > **Vorschaltgerät:**  
regelbar, dimmer inbegriffen.
  
- > **Structure:**  
acier et aluminium verni blanc.
- > **Diffuseur:**  
méthacrylate blanc opalin. Règlable en hauteur.
- > **Diffuseur en tissu:**  
blanc ou noir.
- > **Ballast:**  
réglable avec variateur compris.
  
- > **Estructura:**  
acero y aluminio pintado.
- > **Difusor:**  
metacrilato opalino blanco. Ajustable en altura.
- > **Difusor en tejido:**  
blanco o negro.
- > **Reactór:**  
regulable con dimmer incluido.

## Light data



max 2x20W FBA E27

mm 2800

## Model F50

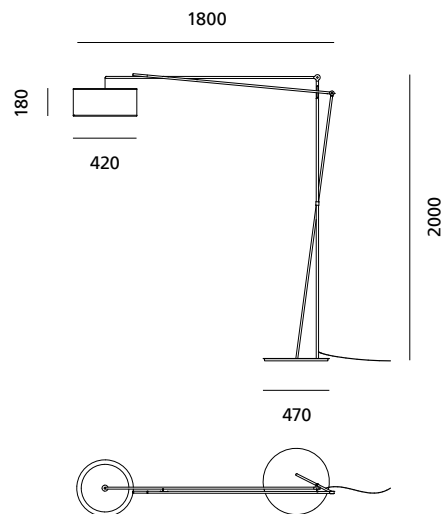

## Colors

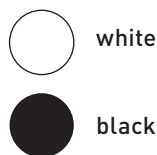







## Structure

- > **Struttura e diffusore:**  
alluminio e polipropilene verniciati opachi.
- > **Reattore:**  
elettronico, dimmerabile a richiesta (ECO F3).  
Dimmer incorporato sul cavo (HALO F3).
- > **Structure and diffuser:**  
matt painted polypropylene and aluminium.
- > **Ballast:**  
electronic, dimmable on request (ECO F3).  
Dimmer on power cord (HALO F3).
- > **Struktur und Leuchtenkörper:**  
Aluminium und Polypropylen  
lackiert Oberfläche.
- > **Vorschaltgerät:**  
elektronisch, dimmbar auf Wunsch (ECO F3).  
Schnur-Zwischen-Dimmer (HALO F3).
- > **Structure et diffuseur:**  
aluminium et polypropylène peints mat.
- > **Ballast:**  
électronique, réglable sur demande (ECO F3).  
Interrupteur sur câble (HALO F3).
- > **Estructura y difusor:**  
aluminio y polipropileno barnizados en mate.
- > **Reactór:**  
electrónico, dimmerable opcional (ECO F3).  
Interruptor incorporado en el cable (HALO F3).

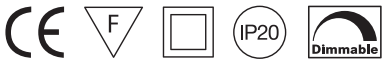
## Light data



 F3 / max 1x500W HDG R7s

 eco F3 / 4x36W FSD 2G11

 mm 2380

## Model F3

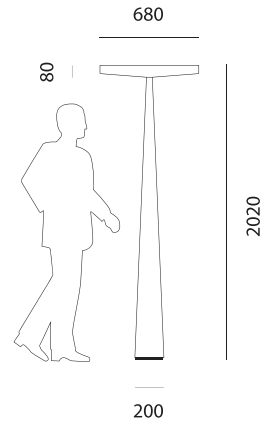

## Colors

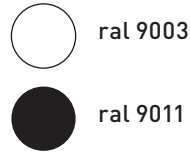



## Structure

- > **Struttura e diffusore:**  
polietilene rotazionale bianco.
- > **Reattore:**  
elettronico. F33 OUTDOOR con base di stabilizzazione su richiesta in metallo verniciato e indice di protezione IP55. F33 INDOOR con interruttore incorporato sul cavo.
- > **Structure and diffuser:**  
white roto-moulded polyethylene.
- > **Ballast:**  
electronic. F33 OUTDOOR with stability and ground fixing base in painted metal on request. IP55 protection. F33 INDOOR with switch on power cord.
- > **Struktur und Leuchtenkörper:**  
Polyethylen satiniert hergestellt im Rotationspritzgussverfahren.
- > **Vorschaltgerät:**  
elektronisch. F33 OUTDOOR auf Wunsch Befestigungsplatte aus lackiertem Metall. Schutzklasse IP55. F33 INDOOR mit Schnur-Zwischen-Schalter.
- > **Structure et diffuseur:**  
polyéthylène roto blanc.
- > **Ballast:**  
électronique. F33 OUTDOOR avec base de stabilisation en métal peint optionnelle. Protection IP55. F33 INDOOR avec Interrupteur sur câble.
- > **Estructura y difusor:**  
polietileno rotacional blanco.
- > **Reactór:**  
Bobina de reacción. F33 OUTDOOR con base de estabilización en metal barnizado opcional. Protección IP55. F33 INDOOR cable con interruptor.

## Light data



○ 1x22W + 1x40W FSC 2GX13

— □ mm 2380

## Model F33

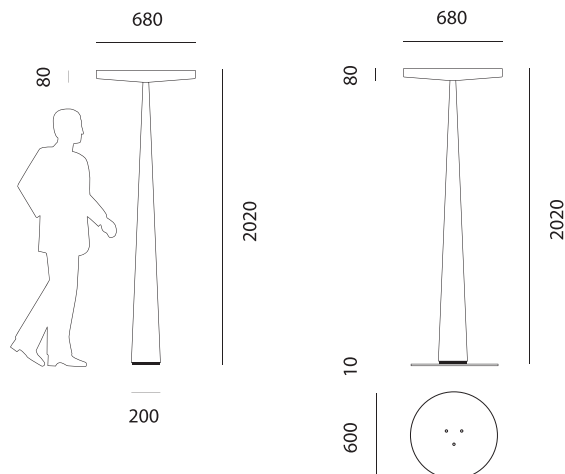

## Colors



**EQUILIBRE F33 DOWNLIGHT**





## Structure

- > **Struttura:**  
polietilene rotazionale verniciato.
- > **Diffusore:**  
lato inferiore diffondente luce verso il basso.
- > **Reattore:**  
elettronico, dimmerabile su richiesta.

- > **Structure:**  
roto-moulded painted polyethylene.
- > **Diffusore:**  
polyethylene material, downward lighting.
- > **Ballast:**  
electronic, dimmable on request.

- > **Struktur:**  
aus Polyäthylen,  
im Rotations-spritzgußverfahren hergestellt.

- > **Diffusor:**  
aus Polyäthylen, Licht nach unten.
- > **Vorschaltgerät:**  
elektronisch, dimmbar auf Wunsch.

- > **Structure:**  
polyéthylène rotomoulé.
- > **Diffuseur:**  
polyéthylène, lumière vers le bas.
- > **Ballast:**  
électronique, réglable sur demande.

- > **Estructura:**  
polietileno rotacional.
- > **Difusor:**  
polietileno, luz hacia abajo.
- > **Reactór:**  
electrónico, dimmerable opcional.

## Light data

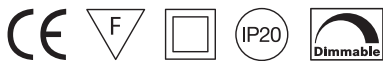

○ 1x22W + 1x40W FSC 2GX13

— □ mm 2380

## Model F33

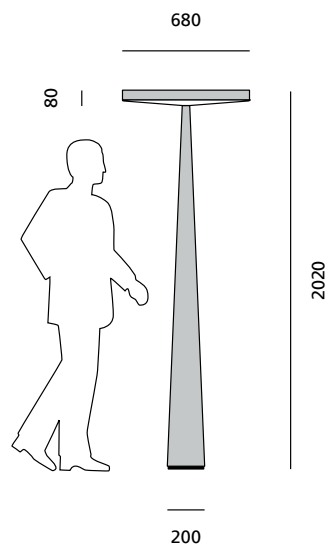

## Colors





Structure

- > *Struttura:*  
acciaio verniciato bianco.
- > *Diffusore:*  
polietilene rotazionale bianco opalino.
- > *Schermo:*  
acciaio verniciato bianco.
  
- > *Structure:*  
white painted steel.
- > *Diffuser:*  
opal white roto-moulded polyethylene.
- > *Shade:*  
white painted steel.
  
- > *Struktur:*  
weiß lackiertes Stahl.
- > *Diffusor:*  
Polyethylen hergestellt  
im Rotations-spritzgussverfahren.
- > *Schirm:*  
weiß lackiertes Stahl.
  
- > *Structure:*  
acier verni blanc.
- > *Diffuseur:*  
polyéthylène roto blanc opalin.
- > *Écran:*  
acier blanc brillant.
  
- > *Estructura:*  
acero barnizado blanco.
- > *Difusor:*  
polietileno rotacional opalino blanco.
- > *Pantalla:*  
acero blanco brillante.

Model F10

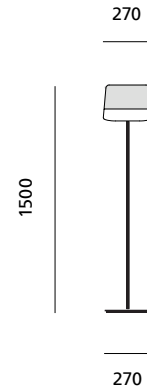

Colors



Light data



☉ max 1x15W FBA E27

— □ mm 2000



## Structure

- > **Struttura:**  
metallo verniciato bianco opaco.
- > **Diffusore:**  
polietilene rotazionale bianco.
- > **Disco inferiore:**  
metacrilato opalino bianco.
  
- > **Structure:**  
matt white painted metal.
- > **Diffuser:**  
white roto-moulded polyethylene.
- > **Lower plate:**  
opal white methacrylate.
  
- > **Struktur:**  
Metall matt weiß lackiert
- > **Leuchtenkörper:**  
Polyethylen hergestellt  
im Rotations-spritzgussverfahren.
- > **Unterer Scheibe:**  
opalweiß Methacrylat.
  
- > **Structure:**  
métal verni blanc mat.
- > **Diffuseur:**  
polyéthylène roto blanc opalin.
- > **Disque inférieur:**  
méthacrylate blanc.
  
- > **Estructura:**  
metal barnizado blanco mate.
- > **Difusor:**  
polietileno rotacional opalino blanco.
- > **Disco inferior:**  
metacrilato opalino blanco.

## Light data



☐ F30.F50 / max 2x15W FBA E27

☐ F30 mm 2610

☐ F50 mm 2480

## Model F30

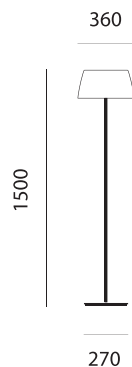

## Model F50

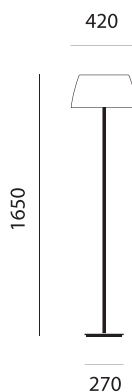

## Colors







## Structure

- > **Struttura:**  
verniciata bianco o nero opaco.
- > **Diffusori:**  
metacrilato opalino bianco.
- > **Reattore:**  
regolabile con dimmer incluso.
  
- > **Structure:**  
matt white or black painted.
- > **Diffusers:**  
opal white methacrylate.
- > **Ballast:**  
dimmer included.
  
- > **Struktur:**  
matt weiß oder schwarz lackiert.
- > **Diffusor:**  
opalweiß Methacrylat.
- > **Vorschaltgerät:**  
regelbar, dimmer inbegriffen.
  
- > **Structure:**  
verni blanc ou noir mat.
- > **Diffuseurs:**  
méthacrylate blanc opalin.
- > **Ballast:**  
réglable avec variateur compris.
  
- > **Estructura:**  
barnizado blanco o negro mate.
- > **Difusores:**  
metacrilato opalino blanco.
- > **Reactór:**  
regulable con dimmer incluido.

## Light data



\* LED 30W+25W - 2700K (5150lm)

mm 2600

## Model F3

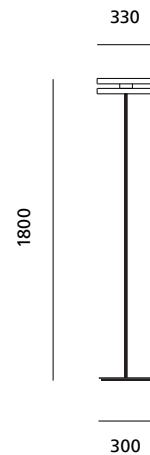

## Colors

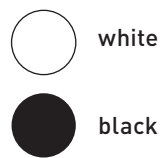

(\*) disponibile in altre versioni / other options available



Structure

---

- > **Struttura:**  
alluminio curvato, verniciato nero opaco.  
Testa LED orientabile in alluminio anodizzato  
e ottica in metacrilato. Braccio con rotazione a 360°.
- > **Versione LED:**  
dimmerabile a richiesta.
  
- > **Structure:**  
bent aluminium painted in matt black.  
LED tilting head with methacrylate optic lens,  
in anodized aluminium. 360° revolving structure.
- > **LED version:**  
dimmable on request.
  
- > **Struktur:**  
schwarz matt lackiertem verbogen Aluminium.  
Verstellbarer LED-Kopf aus eloxiertem  
Aluminium und Optik aus Methacrylat.  
Lampenkörper um 360° schwenkbar.
- > **Version LED:**  
dimmbar auf Wunsch.
  
- > **Structure:**  
aluminium courbé, verni noir mat. Tête LED  
orientable en aluminium anodisé et optique  
en méthacrylate. Diffuseur orientable à 360°.
- > **Version LED:**  
réglable sur demande.
  
- > **Estructura:**  
aluminio curvado barnizado en negro mate.  
Cabeza LED orientable en aluminio anodizado  
y lente en metacrilato. Cuerpo de lampara  
con rotación de 360°.
- > **Version LED:**  
regulable a petición.

Model F3

---

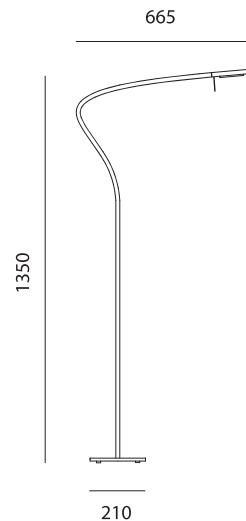

Colors

---



Light data

---

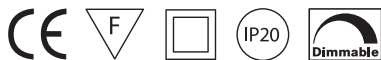

LED 1x6W - 3000K (340lm)

— mm 2300





# ROOM F50.F55 Hettler / Tüllmann - 2007

## Structure

---

- > **Struttura:**  
metallo verniciato bianco opaco.
- > **Diffusore:**  
polietilene rotazionale bianco.
- > **Reattore:**  
elettronico, dimmerabile a richiesta.  
Dimmer a pulsante o interruttore incorporato sul cavo (F50). Indice di protezione IP44 (F55).

- > **Structure:**  
matt white painted metal.
- > **Diffuser:**  
white roto-moulded polyethylene.
- > **Ballast:**  
electronic, dimmable on request.  
Switch or foot control dimmer on power cord (F50). IP44 protection (F55).

- > **Struktur:**  
Metall matt weiß lackiert.
- > **Diffusor:**  
Polyethylen hergestellt im Rotations-spritzgussverfahren.
- > **Vorschaltgerät:**  
elektronisch, dimmbar auf Wunsch.  
Schalter oder Schnur-Zwischen-Dimmer (F50). Schutzklasse IP44 (F55).

- > **Structure:**  
métal verni blanc mat.
- > **Diffuseur:**  
polyéthylène roto blanc opalin.
- > **Ballast:**  
électronique, réglable sur demande.  
Interrupteur ou variateur sur câble (F50). Protection IP44 (F55).

- > **Estructura:**  
metal barnizado blanco opaco.
- > **Difusor:**  
polietileno rotacional blanco.
- > **Reactór:**  
Bobina de reacción con dimmer opcional.  
Cable con interruptor o dimmer (F50). Protección IP44 (F55).

## Model F50.F55

---

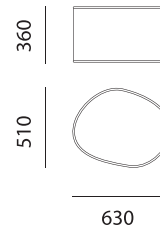

## Colors

---



## Light data

---



1x23W FBT E27

1x32W FSMH GX24q-3

1x42W FSMH GX24q-4

mm 2800



## Structure

---

- > **Struttura:**  
metallo cromato o nichelato spazzolato.
- > **Diffusore:**  
vetro soffiato.
- > **Reattore:**  
regolabile con dimmer incluso.
  
- > **Structure:**  
chrome or brushed nickel metal.
- > **Diffuser:**  
blown glass.
- > **Ballast:**  
dimmer included.

- > **Struktur:**  
Metall verchromt oder Nickel gebürstet.
- > **Diffusor:**  
geblasenes Glas.
- > **Vorschaltgerät:**  
regelbar, dimmer inbegriffen.

- > **Structure:**  
métal chromé ou nickel brossé.
- > **Diffuseur:**  
verre soufflé.
- > **Ballast:**  
réglable avec variateur compris.

- > **Estructura:**  
metal cromado o niquel cepillado.
- > **Difusor:**  
cristal soplado.
- > **Reactór:**  
regulable con dimmer incluido.

## Light data

---



☞ max 1x250W HSGST E27

☞ max 1x150W IAA E27

┌───┐ mm 3050

## Model F1

---

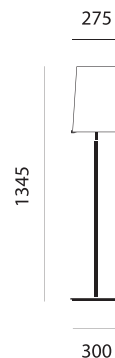

## Colors

---



white



mirror









## Structure

- > **Supporto:**  
metallo verniciato bianco opaco.
- > **Diffusore:**  
cristallo trasparente sabbiato internamente con schermo frontale in vetro.
- > **Reattore:**  
elettronico, dimmerabile a richiesta (W7).
  
- > **Support:**  
matt white painted metal.
- > **Diffuser:**  
transparent and inside sandblasted crystal with glass front screen.
- > **Ballast:**  
electronic, dimmable on request (W7).
  
- > **Halterung:**  
Metall matt weißem lackiert
- > **Diffusor:**  
transparentem Glas innen sandgestrahlt. Vorderseitiger Schirm aus Glas.
- > **Vorschaltgerät:**  
elektronisch, dimmbar auf Wunsch (W7).
  
- > **Support:**  
métal peint blanc mat.
- > **Diffuseur:**  
encadrement en cristal transparent sablé à l'intérieur avec écran frontal en verre.
- > **Ballast:**  
électronique, réglable sur demande (W7).
  
- > **Apoyo:**  
metal barnizado blanco opaco.
- > **Difusor:**  
cristal transparente arenado internamente con pantalla frontal en cristal.
- > **Reactór:**  
bobina de reacción con dimmer opcional (W7).

## Light data



W3 / 1x26W FSQ G24q-3

W4 / 2x26W FSQ G24q-3

W7 / 1x36W FSD 2G11

## Model W3

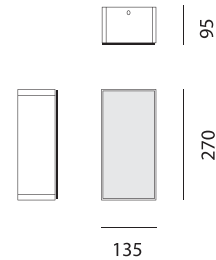

## Model W4

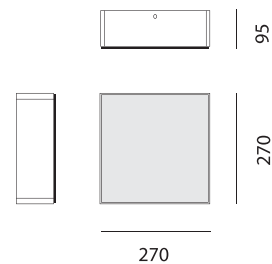

## Model W7

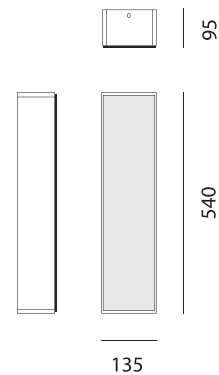

## Colors

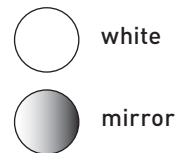



## Structure

> **Struttura:**  
alluminio cromato o verniciato bianco opaco.

> **Diffusore:**  
vetro soffiato opalino satinato o lucido.  
Protezione IP44 in pyrex satinato.

> **Structure:**  
chrome or matt white painted aluminium.

> **Diffuser:**  
satin opal white or bright white blown glass.  
IP44 protection.

> **Befestigung:**  
Aluminium verchromt oder matt weiß lackiert.

> **Diffusor:**  
mundgeblasenes Glas, opal oder weiß  
glänzend. Schutzklasse IP44.

> **Structure:**  
aluminium chromé ou verni blanc mat.

> **Diffuseur:**  
verre soufflé opalin blanc satiné ou brillant.  
Protection IP44.

> **Estructura:**  
aluminio cromado o pintado blanco mate.

> **Difusor:**  
cristal soplado opalino blanco satinado  
o brillante. Protección IP44.

## Light data

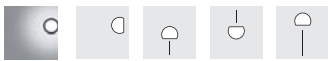

⚡ W1.W3 / max 1x60W HSGST G9

⚡ W5 / max 1x75W HSGST G9

## Model W1

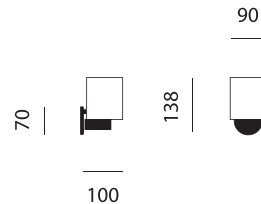

## Model W3

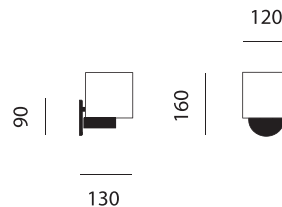

## Model W5

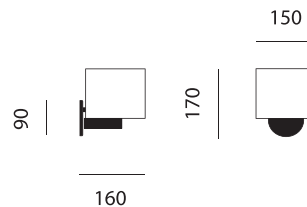

## Colors





## Structure

---

- > **Corpo:**  
termoplastico a iniezione, verniciato in bianco opaco o lucido, con riflettore interno in alluminio.
- > **Reattore:**  
elettronico.
- > **Body:**  
matt or gloss white painted moulded thermoplastic and aluminium reflector.
- > **Ballast:**  
electronic.
- > **Körper:**  
wärmegeformte Schale matt oder glänzendweiß lackiert, Reflektor aus Aluminium.
- > **Vorschaltgerät:**  
elektronisch.
- > **Corps:**  
thermoformé peint blanc mat ou brillant, avec diffuseur en aluminium.
- > **Ballast:**  
électronique.
- > **Cuerpo:**  
termoplastico de inyección barnizado blanco opaco o brillante con reflector interno en aluminio.
- > **Reactór:**  
bobina de reacción.

## Light data

---



 W1 / 1x24W FSS 2G10

 halo W1 / max 1x120W HDG R7s

 W3 / 2x36W FSD 2G11

LED W1 / LED 15,3W – 3000K (1800lm)

LED W3 / LED 30,6W – 3000K (3600lm)

## Model W1

---



## Model W3

---

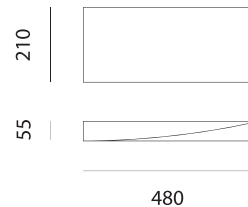

## Colors

---



matt or glossy white





## Structure

- > **Corpo:**  
termoplastico a iniezione, verniciato in bianco opaco o lucido, con riflettore interno in alluminio.
- > **Reattore:**  
elettronico.
- > **Body:**  
matt or gloss white painted moulded thermoplastic and aluminium reflector.
- > **Ballast:**  
electronic.
- > **Körper:**  
wärmegeformte Schale matt oder glänzendweiß lackiert, Reflektor aus Aluminium.
- > **Vorschaltgerät:**  
elektronisch.
- > **Corps:**  
thermoformé peint blanc mat ou brillant, avec diffuseur en aluminium.
- > **Ballast:**  
électronique.
- > **Cuerpo:**  
termoplastico de inyección barnizado blanco opaco o brillante con reflector interno en aluminio.
- > **Reactór:**  
bobina de reacción.

## Light data



 WW1 / 1x26W FSQ G24q-3

 WW3 / 1x36W FSD 2G11

LED WW1 / LED 14,4W – 3000K (1060lm)

## Model WW1

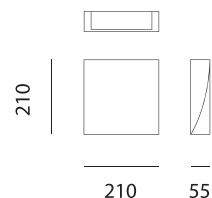

## Model WW3

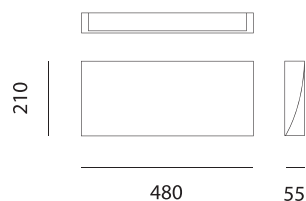

## Colors



matt or glossy white

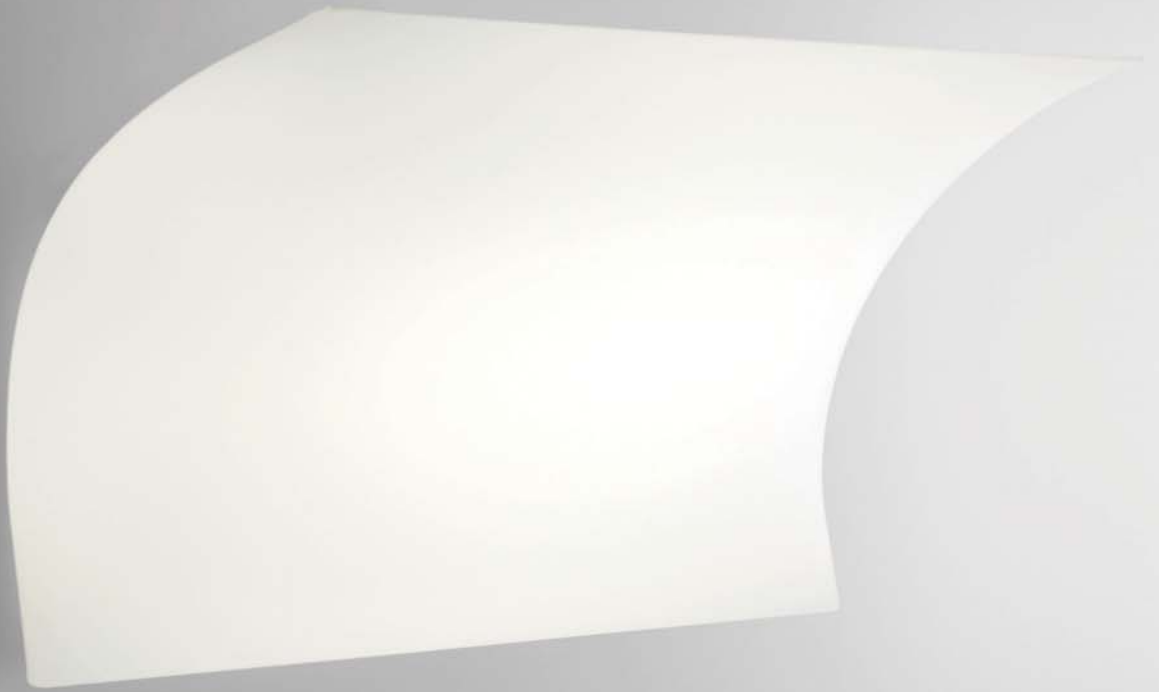

### Structure

- > **Supporto a muro:**  
metallo verniciato bianco opaco.
- > **Struttura:**  
lastra in polipropilene opalino.
- > **Diffusore:**  
involucro sfoderabile e lavabile in microfibra poliestere bianco.
- > **Reattore:**  
elettronico, dimmerabile a richiesta.  
Versione LED, dimmerabile a richiesta.
- > **Wall support:**  
matt white painted metal.
- > **Structure:**  
opal polypropylene slab.
- > **Diffuser:**  
white polyester micro-fibre fabric,  
removable and washable.
- > **Ballast:**  
electronic, dimmable on request.  
LED version, dimmable on request.
- > **Halterung:**  
Metall matt weiß lackiert.
- > **Struktur:**  
gebogene Polypropylenplatte weiß.
- > **Diffusor:**  
Mikrofasergewebe weiß, abnehmbar und waschbar.
- > **Vorschaltgerät:**  
elektronisch, dimmbar auf Wunsch.  
Version LED, dimmbar auf Wunsch.
- > **Support:**  
métal verni blanc mat.
- > **Structure:**  
armature en polypropylène opale.
- > **Diffuseur:**  
hausse déhoussable et lavable in microfibre polyester blanc.
- > **Ballast:**  
électronique, réglable sur demande.  
Version LED, réglable sur demande.
- > **Apoyo:**  
metal barnizado blanco mate.
- > **Estructura:**  
lastra en polipropileno opalino.
- > **Difusor:**  
envoltorio extraíble y lavable en microfibra poliester blanco.
- > **Reactór:**  
bobina de reacción con dimmer opcional.  
Version LED, regulable a petición.

### Light data



 21W / 1x26W FSQ G24q-3

 22W / 1x36W FSD 2G11

 23W / 1x55W FSDH 2G11

LED 21W / 16,8W - 3000K (1810lm)

LED 22W / 15,6W - 3000K (2160lm)

LED 23W / 31,5W - 3000K (4320lm)

### Model 21W

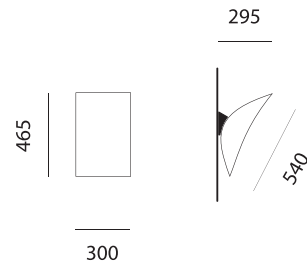

### Model 22W

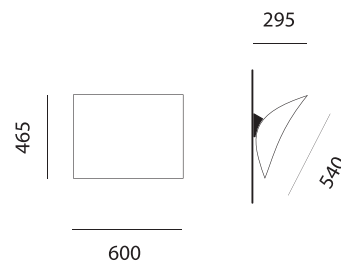

### Model 23W

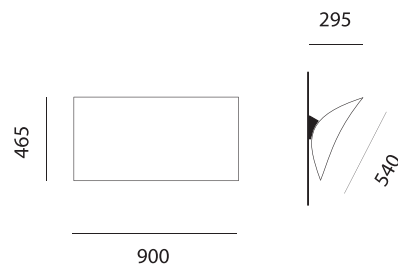

### Colors





# LIN W1 Mengotti / Prandina - 1992

## Structure

---

- > **Supporto:**  
cristallo pressato. Anelli ferma lampada  
metallici in dotazione.
- > **Support:**  
pressed crystal. Bulb fixing-rings included.
- > **Halterung:**  
gepresster Kristall.  
Leuchtmittelhalterungen inbegriffen.
- > **Support:**  
cristal pressé. Bagues fixe-ampoule  
comprises.
- > **Apoyo:**  
cristal prensado. Anillos sujeta  
Linestra incluidos.

## Model W1

---

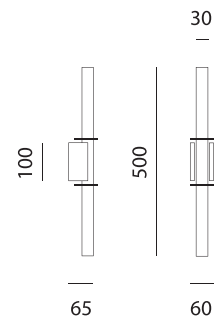

## Colors

---



## Light data

---



1x11W EIT/D S14d

LED / 1x6W DRL-DE S14d





## Structure

- > **Struttura:**  
metallo verniciato bianco.
- > **Diffusore interno:**  
polietilene rotazionale bianco opalino.
- > **Diffusore esterno:**  
vetro soffiato opalino satinato bianco.
- > **Reattore:**  
elettronico, dimmerabile a richiesta (W5).

- > **Structure:**  
matt white painted metal.
- > **Inner diffuser:**  
white roto-moulded polyethylene.
- > **Outer diffuser:**  
satin white opal blown glass.
- > **Ballast:**  
electronic, dimmable on request (W5).

- > **Struktur:**  
Metall, weiß matt lackiert.
- > **Innerer Diffusor:**  
Polyethylen satiniert hergestellt im Rotations-spritzgussverfahren.
- > **Außer Diffusor:**  
geblasenes Glas opalweiß.
- > **Vorschaltgerät:**  
elektronisch, dimmbar auf Wunsch (W5).

- > **Structure:**  
métal verni blanc opaque.
- > **Diffuseur intérieur:**  
polyéthylène roto blanc.
- > **Diffuseur extérieur:**  
verre opalin soufflé satiné blanc.
- > **Ballast:**  
électronique, réglable sur demande (W5).

- > **Estructura:**  
metal barnizado blanco opaco.
- > **Difusor interno:**  
polietileno rotacional blanco opalino.
- > **Difusor externo:**  
cristal soplado opalino satinado blanco.
- > **Reactór:**  
bobina de reacción con dimmer opcional (W5).

## Model W3

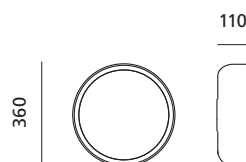

## Model W4.W5

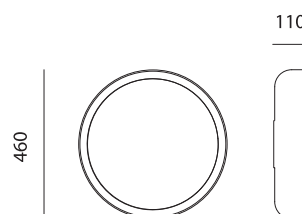

## Light data



○ W4 / 1x40W FSC 2GX13 (3400lm)

○ W5 / 1x55W FSC 2GX13 (4200lm)

\* LED W3 / LED 25W - 2700K (2300lm)

\* LED W4 / LED 30W - 2700K (2850lm)

\* LED W5 / LED 55W - 2700K (5150lm)

## Colors



(\*) disponibile in altre versioni / other options available





## Structure

- > **Supporto a muro:**  
metallo verniciato bianco opaco.
- > **Diffusore:**  
vetro soffiato opalino satinato bianco  
con filtri inferiore e superiore in vetro bianco.
- > **Reattore:**  
elettronico (ECO W3).
  
- > **Wall support:**  
matt white painted metal.
- > **Diffuser:**  
satin white opal blown glass with white  
upper and lower glass filters.
- > **Ballast:**  
electronic (ECO W3).
  
- > **Halterung:**  
Metall matt weiß lackiert.
- > **Diffusor:**  
geblasenes Glas opalweiß.  
Oberer und unterer Glasfilter weiß satiniert.
- > **Vorschaltgerät:**  
elektronisch (ECO W3).
  
- > **Support:**  
métal verni blanc opaque.
- > **Diffuseur:**  
verre opalin soufflé satiné blanc avec filtre  
supérieur et inférieur en verre blanc.
- > **Ballast:**  
électronique (ECO W3).
  
- > **Apoyo:**  
metal barnizado blanco opaco.
- > **Difusor:**  
cristal soplado opalino satinado blanco con fil-  
tros superiores e interiores en cristal blanco.
- > **Reactór:**  
bobina de reacción (ECO W3).

## Light data



 W3 / max 2x60W IAA E27

 W3 / 2x23W FBT E27

 ECO W3 / 1x26W FSQ G24q-3

## Model Small W3

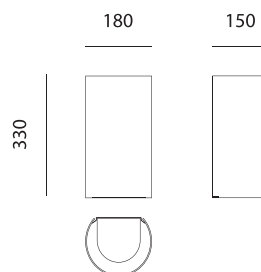

## Model W3

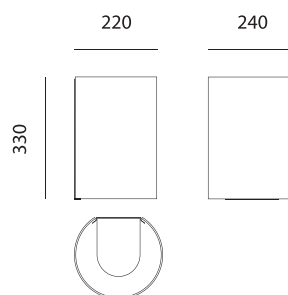

## Colors





# PLATONE W1.W3 Filippo Protasoni - 2009

## Structure

---

- > **Supporto a muro:**  
metallo.
- > **Corpo:**  
termoplastico verniciato bianco opaco,  
con riflettore interno in alluminio.
- > **Reattore:**  
elettronico.
  
- > **Wall support:**  
metal.
- > **Body:**  
matt white painted thermoplastic  
with an aluminium reflector.
- > **Ballast:**  
electronic.
  
- > **Halterung:**  
Metall.
- > **Leuchtenkörper:**  
wärmegeformte Schale matt weiß lackiert,  
Reflektor aus Aluminium
- > **Vorschaltgerät:**  
elektronisch.
  
- > **Support:**  
métal.
- > **Corps:**  
thermoformé peint blanc mat,  
avec diffuseur en aluminium.
- > **Ballast:**  
électronique.
  
- > **Apoyo:**  
metal.
- > **Cuerpo:**  
termoplástico barnizado blanco mate  
con reflector interno en aluminio.
- > **Reactór:**  
bobina de reacción.

## Light data

---



 W1 / max 1x60W HSGST G9

 eco W3 / 1x36W FSS 2G10

\* LED W1 / LED 4,2W – 3000K (720lm)

\* LED W3 / LED 15,3W – 3000K (1800lm)

(\*) disponibile in altre versioni / other options available

## Model W1

---

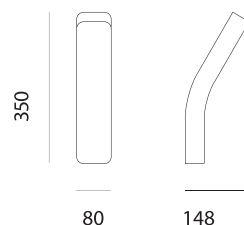

## Model W3

---

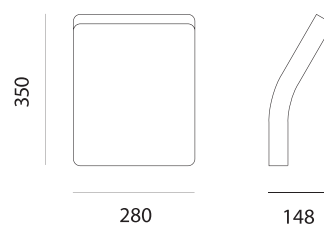

## Colors

---



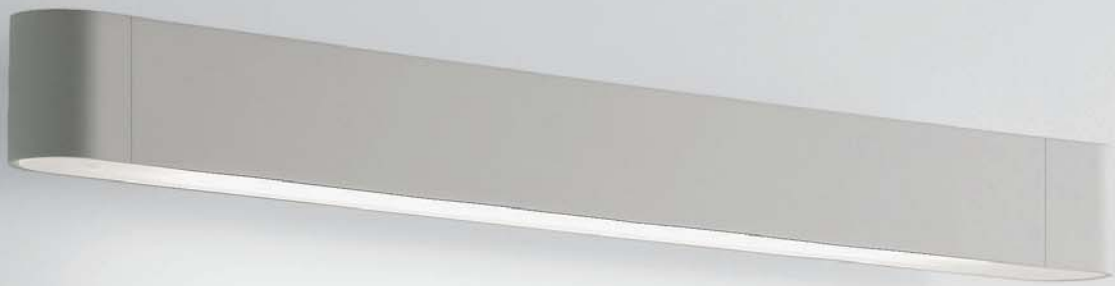



## Structure

- > **Corpo:**  
alluminio verniciato.
- > **Reattore:**  
elettronico, dimmerabile a richiesta.  
Versione LED, dimmerabile a richiesta.
- > **Body:**  
painted aluminium.
- > **Ballast:**  
electronic, dimmable on request.  
LED version, dimmable on request.
- > **Lampenkörper:**  
lackiertes Aluminium.
- > **Vorschaltgerät:**  
elektronisch, dimmbar auf Wunsch.  
Version LED, dimmbar auf Wunsch.
- > **Corps:**  
aluminium verni.
- > **Ballast:**  
électronique, réglable sur demande.  
Version LED, réglable sur demande.
- > **Cuerpo:**  
aluminio barnizado.
- > **Reactór:**  
bobina de reacción con dimmer opcional.  
Version LED, regulable a petición.

## Light data



- W1 / 1x24W FDH G5
- W3 / 1x39W FDH G5
- W5 / 1x54W FDH G5
- W7 / 1x80W FDH G5

- \* LED W1 / 23,6W – 3000K (2800lm)
- \* LED W3 / 35,4W – 3000K (4200lm)
- \* LED W5 / 47,2W – 3000K (5600lm)
- \* LED W7 / 59W – 3000K (7000lm)

(\*) disponibile in altre versioni / other options available

## Model W1

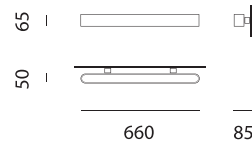

## Model W3

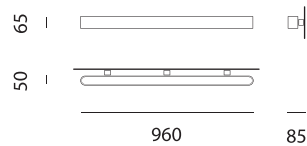

## Model W5

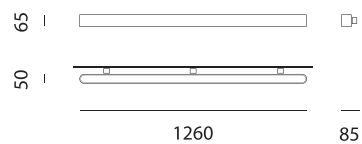

## Model W7

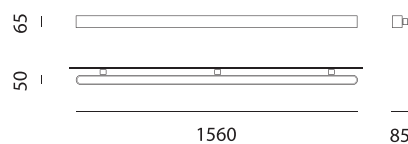

## Colors









## Structure

- > **Supporto:**  
metallo verniciato bianco opaco.
- > **Diffusore:**  
cristallo trasparente sabbiato internamente con schermo frontale in vetro.
- > **Reattore:**  
elettronico, dimmerabile a richiesta (W7).
  
- > **Support:**  
matt white painted metal.
- > **Diffuser:**  
transparent and inside sandblasted crystal with glass front screen.
- > **Ballast:**  
electronic, dimmable on request (W7).
  
- > **Halterung:**  
Metall matt weißem lackiert
- > **Diffusor:**  
transparentem Glas innen sandgestrahlt. Vorderseitiger Schirm aus Glas.
- > **Vorschaltgerät:**  
elektronisch, dimmbar auf Wunsch (W7).
  
- > **Support:**  
métal peint blanc mat.
- > **Diffuseur:**  
encadrement en cristal transparent sablé à l'intérieur avec écran frontal en verre.
- > **Ballast:**  
électronique, réglable sur demande (W7).
  
- > **Apoyo:**  
metal barnizado blanco opaco.
- > **Difusor:**  
cristal transparente arenado internamente con pantalla frontal en cristal.
- > **Reactór:**  
bobina de reacción con dimmer opcional (W7).

## Light data



W3 / 1x26W FSQ G24q-3

W4 / 2x26W FSQ G24q-3

W7 / 1x36W FSD 2G11

## Model W3

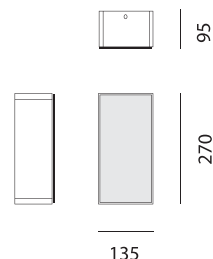

## Model W4

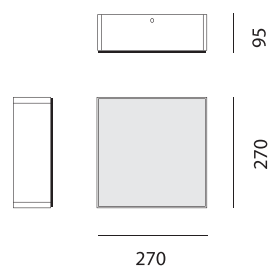

## Model W7

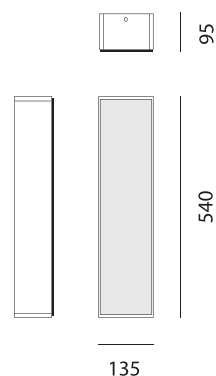

## Colors

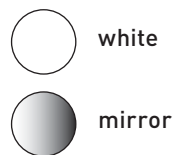





## Structure

- > **Struttura e diffusore:**  
alluminio verniciato opaco.
- > **Reattore:**  
elettronico, dimmerabile a richiesta (ECO C3).
- > **Structure and diffuser:**  
matt painted aluminium.
- > **Ballast:**  
electronic, dimmable on request (ECO C3).
- > **Struktur und Leuchtenkörper:**  
Aluminium matt lackiert.
- > **Vorschaltgerät:**  
elektronisch, dimmbar auf Wunsch (ECO C3).
- > **Structure et diffuseur:**  
aluminium verni opaque.
- > **Ballast:**  
électronique, réglable sur demande (ECO C3).
- > **Estructura y difusor:**  
aluminio barnizado opaco.
- > **Reactór:**  
bobina de reacción,  
con dimmer opcional (ECO C3).

## Light data



  Halo C3 / 3x150W HDG R7s + 1x40W HMGS/UB G9

  Eco C3 / 4x36W FSD 2G11 + 1x40W HMGS/UB G9

## Model C3

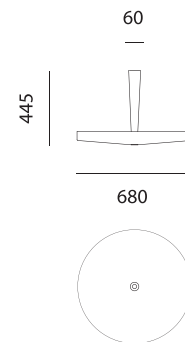

## Colors



white



silver



## Structure

- > **Struttura:**  
metallo verniciato bianco opaco.
- > **Diffusore:**  
polietilene rotazionale bianco.
- > **Reattore:**  
elettronico, dimmerabile a richiesta.

- > **Structure:**  
matt white painted metal.
- > **Diffuser:**  
white roto-moulded polyethylene.
- > **Ballast:**  
electronic, dimmable on request.

- > **Struktur:**  
matt weiß lackiert Metall.
- > **Diffusor:**  
Polyethylen satiniert hergestellt  
im Rotations-spritzgussverfahren.
- > **Vorschaltgerät:**  
elektronisch, dimmbar auf Wunsch.

- > **Structure:**  
métal verni blanc mat.
- > **Diffuser:**  
polyéthylène roto blanc.
- > **Ballast:**  
électronique, réglable sur demande.

- > **Estructura:**  
metal barnizado blanco opaco
- > **Difusor:**  
polietileno rotacional blanco.
- > **Reactór:**  
bobina de reacción, con dimmer opcional.

## Light data



○ 1x22W FSC 2GX13 + 1x40W FSC 2GX13

## Model C33

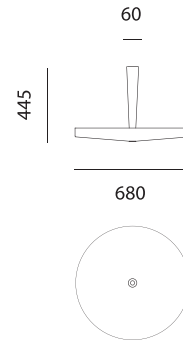

## Colors





## Structure

---

> **Struttura:**  
 metallo cromato oppure vetro soffiato bianco.

> **Diffusore:**  
 vetro soffiato.

> **Structure:**  
 chrome metal or satin white blown glass.

> **Diffuser:**  
 blown glass.

> **Struktur:**  
 Metall verchromt oder geblasenes  
 Glas weiß satiniert.

> **Diffusor:**  
 geblasenes Glas.

> **Structure:**  
 métal chromé ou verre soufflé satiné blanc.

> **Diffuseur:**  
 verre soufflé.

> **Estructura:**  
 metal cromado o cristal soplado  
 satinado blanco.

> **Difusor:**  
 cristal soplado.

## Light data

---



☞ max 1x100W IAA E27

☞ max 1x100W IAM E27

☞ 1x23W FBT E27

## Model C1

---

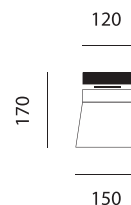

## Model C1G

---



## Model C3

---

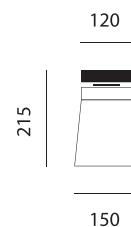

## Model C3G

---

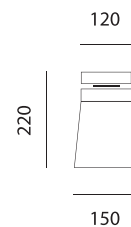

## Colors

---







## Structure

- > **Supporto a muro:**  
metallo verniciato bianco opaco.
- > **Struttura:**  
lastra in polipropilene opalino.
- > **Diffusore:**  
involucro sfoderabile e lavabile in microfibra poliestere bianco.
- > **Reattore:**  
elettronico, dimmerabile a richiesta.  
Versione LED, dimmerabile a richiesta.
  
- > **Wall support:**  
matt white painted metal.
- > **Structure:**  
opal polypropylene slab.
- > **Diffuser:**  
white polyester micro-fibre fabric,  
removable and washable.
- > **Ballast:**  
electronic, dimmable on request.  
LED version, dimmable on request.
  
- > **Halterung:**  
Metall matt weiß lackiert.
- > **Struktur:**  
gebogene Polypropylenplatte weiß.
- > **Diffusor:**  
Mikrofasergewebe weiß, abnehmbar und waschbar.
- > **Vorschaltgerät:**  
elektronisch, dimmbar auf Wunsch.  
Version LED, dimmbar auf Wunsch.
  
- > **Support:**  
métal verni blanc mat.
- > **Structure:**  
armature en polypropylène opale.
- > **Diffuseur:**  
hausse déhoussable et lavable in microfibre polyester blanc.
- > **Ballast:**  
électronique, réglable sur demande.  
Version LED, réglable sur demande.
  
- > **Apoyo:**  
metal barnizado blanco mate.
- > **Estructura:**  
lastra en polipropileno opalino.
- > **Diffusor:**  
envoltorio extraíble y lavable en microfibra poliéster blanco.
- > **Reactór:**  
bobina de reacción con dimmer opcional.  
Version LED, regulable a petición.

## Light data



 21W / 1x26W FSQ G24q-3

 22W / 1x36W FSD 2G11

 23W / 1x55W FSDH 2G11

LED 21W / 16,8W - 3000K (1810lm)

LED 22W / 15,6W - 3000K (2160lm)

LED 23W / 31,5W - 3000K (4320lm)

## Model 21C

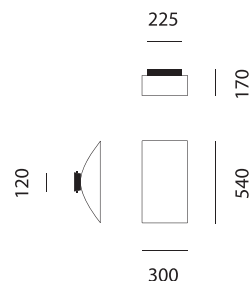

## Model 22C

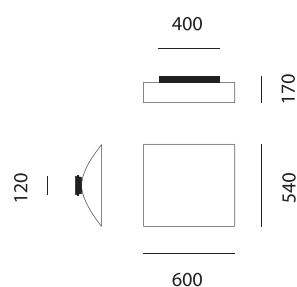

## Model 23C

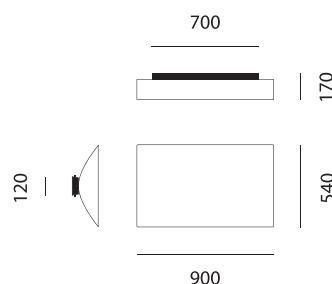

## Colors



white



## Structure

---

- > **Struttura:**  
metallo verniciato bianco.
- > **Diffusore interno:**  
polietilene rotazionale bianco opalino.
- > **Diffusore esterno:**  
vetro soffiato opalino satinato bianco.
- > **Reattore:**  
elettronico, dimmerabile a richiesta (W5).

- > **Structure:**  
matt white painted metal.
- > **Inner diffuser:**  
white roto-moulded polyethylene.
- > **Outer diffuser:**  
satin white opal blown glass.
- > **Ballast:**  
electronic, dimmable on request (W5).

- > **Struktur:**  
Metall, weiß matt lackiert.
- > **Innerer Diffusor:**  
Polyethylen satiniert hergestellt im Rotations-spritzgussverfahren.
- > **Außer Diffusor:**  
geblasenes Glas opalweiß.
- > **Vorschaltgerät:**  
elektronisch, dimmbar auf Wunsch (W5).

- > **Structure:**  
métal verni blanc opaque.
- > **Diffuseur intérieur:**  
polyéthylène roto blanc.
- > **Diffuseur extérieur:**  
verre opalin soufflé satiné blanc.
- > **Ballast:**  
électronique, réglable sur demande (W5).

- > **Estructura:**  
metal barnizado blanco opaco.
- > **Difusor interno:**  
polietileno rotacional blanco opalino.
- > **Difusor externo:**  
cristal soplado opalino satinado blanco.
- > **Reactór:**  
bobina de reacción con dimmer opcional (W5).

## Model W3

---

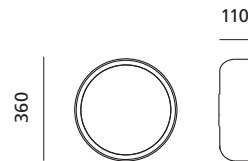

## Model W4.W5

---

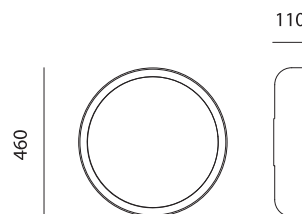

## Light data

---



○ W4 / 1x40W FSC 2GX13 (3400lm)

○ W5 / 1x55W FSC 2GX13 (4200lm)

\* LED W3 / LED 25W - 2700K (2300lm)

\* LED W4 / LED 30W - 2700K (2850lm)

\* LED W5 / LED 55W - 2700K (5150lm)

## Colors

---



(\*) disponibile in altre versioni / other options available















## CREDITS

---

Art direction

*Marco Viola Studio*

Layout

*Andrea Battello - Marco Viola Studio*

Photography

*Alessandro Paderni - Studio Eye*

*Gianluca Badocco*

*Alberto Parise*

Printed By

*Chinchio Industria Grafica srl*

## CONTACTS

---

Prandina Srl  
Via Rambolina, 29  
36061 Bassano del Grappa (VI) Italy  
Tel +39.0424.566338  
www.prandina.it

*prezzo al pubblico 27,00 euro*



