

SATTTLER

LIVING
COLLECTION

LIVING COLLECTION

Ausgewählte Leuchten für Ihren ganz persönlichen Lieblingsplatz.

Selected lights for your personal favorite place.







Wir möchten Sie mit der SATTLER „LIVING COLLECTION“ begeistern und Ihnen für Ihr Zuhause-Gefühl zu jeder Tages- und Nachtzeit das richtige Licht bieten. Daher haben wir ein Portfolio aus hochwertigen LED-Designleuchten für Ihr Wohnerlebnis zusammengestellt, die in der modernen Innenraumgestaltung wohlthuende Akzente setzen und sich gleichzeitig unaufdringlich und zeitlos schön in Ihre Räumlichkeiten integrieren lassen. Ob Pendelleuchte, Spot, Steh- oder Tischleuchte, alle überzeugen durch formschöne Details, wertige Materialien und edle Oberflächenveredelungen. Einzelne oder kreativ kombiniert, die SATTLER „LIVING COLLECTION“ bietet für jeden Wohnbereich die für Sie passende Leuchte.

We want to inspire you with the SATTLER „LIVING COLLECTION“ and offer you the right light for your feeling of home at any time of the day or night. That is why we have put together a portfolio of high-quality LED design luminaires for your living experience, which set pleasant accents in modern interior design and at the same time can be integrated into your rooms unobtrusively with timeless elegance. Whether pendant luminaire, spot, floor or table luminaire, they all convince with beautiful details, high-quality materials and noble surface finishings. With unique luminaires or creative combinations the SATTLER „LIVING COLLECTION“ offers the right illumination for every living area.



W
E
L
I
V
I
N
G
C
O
L
L
E
C
T
I
O
N



EVOLUTION SPOT - PALADIO OPAL - PALITO MIKADO - INSOSPESO FLOOR

Über 60 Jahre Ideen, Innovationen und Werte
Over 60 years of ideas, innovations and values

COMPANY

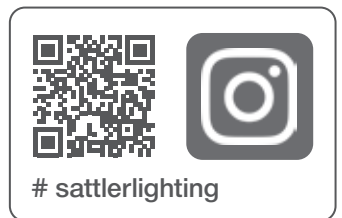

Seit der Unternehmensgründung in den 50er Jahren haben wir uns zu einem international tätigen Produktionsunternehmen mit rund 70 Mitarbeitern entwickelt. SATTLER - über drei Generationen hinweg, vom Elektroinstallationsbetrieb, der Lichtplanung und Montage, hin zu einem führenden Leuchtenhersteller, wurde viel bewegt. Heute blicken wir auf mehr als 30 Jahre Erfahrung in der Beleuchtungsbranche zurück und bieten dem Markt ein innovatives Portfolio an Designleuchten für den privaten und gewerblichen Kunden. Neben dem regulären Portfolio an Katalogleuchten ermöglicht die eigene Produktion das Anfertigen von projektbezogenen Sonderlösungen jeder Größenordnung.

Since the company was founded in the 1950s, we have developed into an internationally active production company with around 70 employees. SATTLER - over three generations, from an electrical installation company, lighting design and installation, to a leading luminaire manufacturer, a lot has been moved. Today, we can look back on more than 30 years of experience in the lighting industry and offer the market an innovative range of designer luminaires for private and commercial customers. In addition to the regular portfolio of catalogue luminaires, our own production enables us to manufacture project-specific special solutions of any size.

SATTTLER

Fertigung und Verwaltung in Göppingen
Production and administration in Göppingen

Um die gewünschten hohen Qualitätsstandards zu erreichen, steckt in SATTLER Leuchten viel Handarbeit, zugleich sind unsere Prozesse jedoch auf effiziente Fertigung ausgelegt. Spezielle Produktionsbereiche für unterschiedliche Leuchtentypen und eine hohe In-House Fertigungstiefe garantieren eine kontinuierlich hohe Detailqualität unserer Leuchten. Wir setzen auf erfahrene Fachkräfte mit praktischem Hintergrund sowie regionale Zulieferer mit Spezialwissen im jeweiligen Arbeitsschritt.

In order to achieve the desired high quality standards, SATTLER luminaires involve a lot of manual work but at the same time our processes are designed for efficient production. Special production areas for different types of luminaires and a high in-house production depth guarantee a continuously high quality in details of our luminaires. We rely on experienced specialists with practical backgrounds as well as on regional suppliers with specialised knowledge in the respective work step.



PRODUCTION

MADE IN GERMANY

**GLOBAL DENKEN – LOKAL HANDELN
THINK GLOBAL, ACT LOCAL**

100% Deutschland 

- | | |
|---------------------|----------------------|
| + Entwicklung | + Development |
| + Produktdesign | + Product design |
| + LED-Bestückung | + LED assembly |
| + Metallbearbeitung | + Metalworking |
| + Beschichtung | + Coating |
| + Montage & Prüfung | + Assembly & Testing |



Deutsche Qualität

Wir haben unsere Leuchtenproduktion regional ausgerichtet und arbeiten seit Jahren nur mit ausgewählten Industrie- und Handwerkspartnern zusammen, die sich wie wir qualitativen Produkten und innovativen Fertigungstechniken verschrieben haben. **100% -Prüfung** - Jede Leuchte wird zudem vor Auslieferung funktionell und optisch geprüft.

„Grüne Produktion“

- Wir legen Wert auf kurze Wege von Zulieferern.
- 70% unseres Strombedarfs gewinnen wir aus eigener Photovoltaikanlage, den Rest kaufen wir aus erneuerbaren Energiequellen zu.
- Geheizt wird über Wärmetauscher und Gebäudekernaktivierung für ein effizientes Wärmemanagement.
- Unser Fuhrpark ist mit umweltfreundlicher Hybrid-Technologie ausgerüstet.
- Wir reduzieren Verpackungs- und Verbrauchsmaterialien und achten bei der Wahl auf Recyclefähigkeit bzw. umweltgerechte Entsorgung.
- Unsere Produkte werden von uns nach dem Prinzip der Wiederverwendbarkeit in der Kreislaufwirtschaft entwickelt. Derzeit arbeiten wir auch an entsprechender Zertifizierung.



German quality

Our luminaire production is regionally oriented and we have been working for years only with selected suppliers and partners who, like us, are committed to qualitative products and innovative manufacturing techniques. **100% testing** - Each luminaire is also functionally and visually tested before delivery.

„Green Production“

- We attach importance to short distances from suppliers. 70% of our electricity is generated by our own photovoltaic system, the rest is purchased as green electricity.
- Heating is provided by heat exchangers and building core activation for efficient heat management.
- Our vehicle fleet is equipped with environmentally friendly hybrid technology.
- We reduce packaging and consumables and pay attention to reusability or eco-friendly waste disposal.
- We develop our products based on the principle of reusability in the circular economy. Currently we are working on the respective certification.



Blick in unsere Produktion
Look into our production



Ulrich Sattler | Michael Schmidt



DESIGN

Unser Designteam setzt sich um den kreativen Kopf Ulrich Sattler aus eigenen und externen Designern zusammen. In diesem wechselseitigen Prozess können neue Ideen auf kurzen Wegen in aussagefähige Prototypen umgesetzt werden. Die rasche Umsetzung mittels neuester Fertigungsverfahren, vom Konzept zum Produkt, hat es uns kontinuierlich ermöglicht, den Markt mit Neuentwicklungen und Innovationen auf hohem Qualitätsniveau zu überraschen. Bestätigung für gutes Design und Funktionalität finden unsere Leuchten durch zahlreiche in den letzten Jahren gewonnene Design- und Innovationspreise, wie den iF-Design Award, den RedDot Design Award und den Focus Open Award.

Our design team is made up of our own and external designers around the creative head Ulrich Sattler. In this reciprocal process, new ideas can be transformed into meaningful prototypes in the shortest possible time. The rapid implementation of the latest manufacturing processes, from concept to product, has enabled us to continuously surprise the market with new developments and innovations at a high level of quality. Our luminaires have received numerous design and innovation awards in recent years, such as the iF Design Award, the RedDot Design Award and the Focus Open Award, which confirm their good design and functionality.

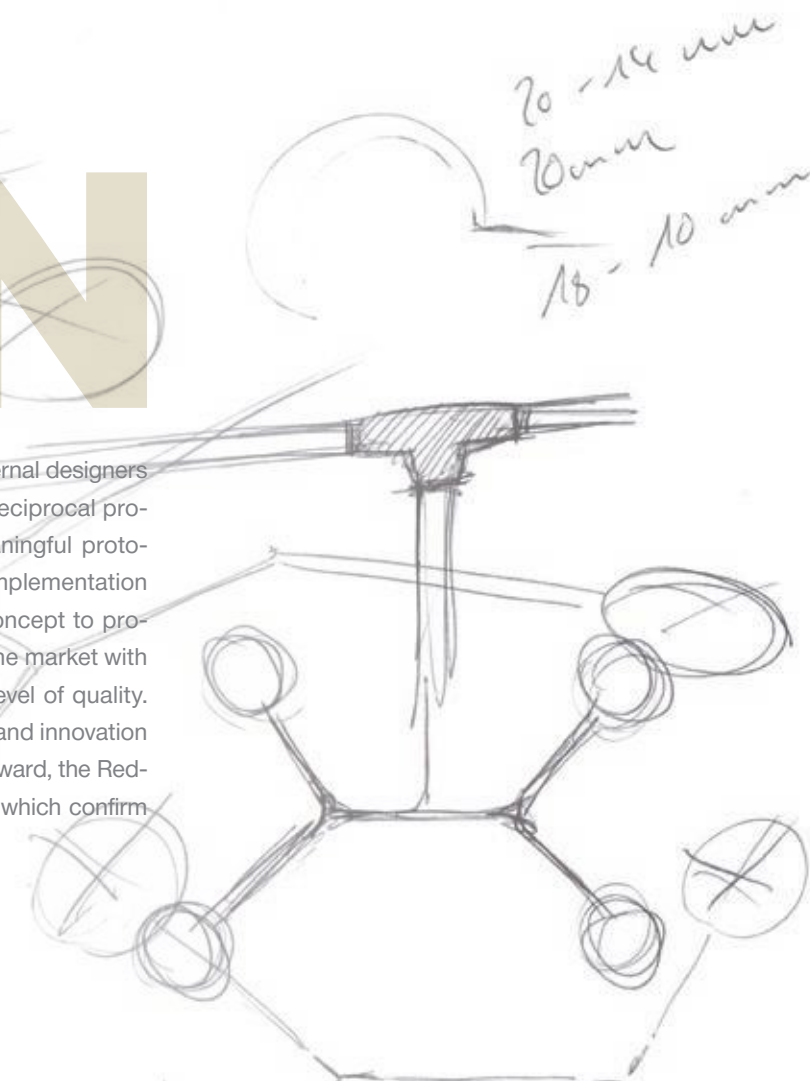



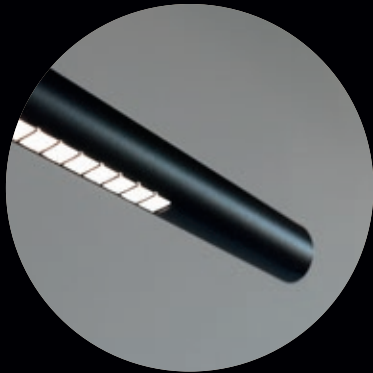

feel it

Da der Charakter einer Leuchte stark durch die verwendeten Werkstoffe beeinflusst wird, weisen wir deren Auswahl einen hohen Stellenwert zu und verwenden nur qualitativ hochwertige Rohmaterialien. Zudem setzen wir auf ausgesuchte Veredelungsprozesse, welche unseren Leuchten das gewisse Etwas verleihen.

Since the character of a luminaire is strongly influenced by the materials used, we attach great importance to their selection and only use high-quality materials. In addition, we rely on selected finishing processes that give our luminaires that certain something.

& LOOK

MATERIAL



12 Aluminium, pulverbeschichtet, Feinstruktur, Weiß (RAL 9003)
Aluminium, powder-coated, fine textured, white (RAL 9003)

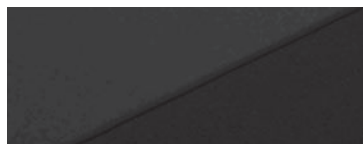

10 Aluminium, pulverbeschichtet, Feinstruktur, Schwarz
Aluminium, powder-coated, fine textured, black

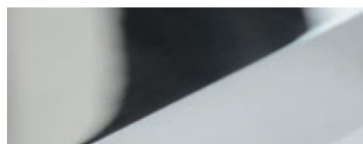

22 Aluminium, handpoliert
Aluminium, hand polished



65 Aluminium, gebürstet und eloxiert, Champagner-Gold
Aluminium, anodised, brushed, champagne gold



66 Aluminium, gebürstet und eloxiert, Bronze
Aluminium, anodised, brushed, bronze

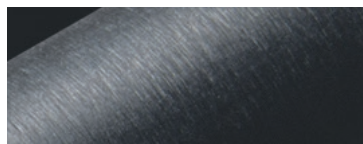

62 Aluminium, gebürstet und eloxiert, Schwarz
Aluminium, anodised, brushed, black



60 Aluminium, gebürstet und eloxiert, Silber
Aluminium, anodised, brushed, silver

TECHNOLOGY

Als Hersteller qualitativ hochwertiger Leuchten legen wir besonderes Augenmerk auf die in unseren Leuchten verwendeten elektrotechnischen Bauteile. Um unseren Kunden höchste Qualität in Einklang mit dem größtmöglichen Nutzen zu bieten, arbeitet unser Designteam Hand in Hand mit unseren Technikern. Denn erst die richtige Lichtfarbe und -qualität sowie die passende Dimmung vollenden das tägliche individuelle Lichterlebnis.

As a manufacturer of high-quality luminaires, we pay special attention to the electrotechnical components used in our luminaires. In order to offer our customers the highest quality in combination with the greatest possible benefit, our design team works hand in hand with our technicians. Because only the right light colour and quality together with the appropriate dimming complete the daily individual experience of light.

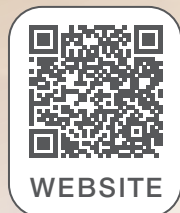

Die Vorteile von LED

- Leuchten mit LED-Technik verbrauchen deutlich weniger Energie als herkömmliche Leuchtmittel.
- Die Lebensdauer einer LED beträgt über 50.000 Stunden.
- Leuchten mit LED-Technik haben eine geringere Wärmeentwicklung.
- Die Baugröße der LEDs ermöglicht ein filigranes Leuchtendesign.
- Luminaires with LED technology consume significantly less energy than conventional light sources.
- The service life of an LED is over 50,000 hours.
- Luminaires with LED technology generate less heat.
- The size of the LEDs enables a filigree luminaire design.



Die Farbe des Lichts

Die Farbtemperatur, angegeben in Kelvin (K), bestimmt die Lichtfarbe einer LED-Leuchte.

2700 K Extra Warmweiß - warmes, gemütliches Licht.

3000 K Warmweiß - wohnliches Licht, jedoch etwas neutraler.

The colour temperature, specified in Kelvin (K), determines the light colour of an LED luminaire.

2700 K Extra warm white - warm, cosy light.

3000 K Warm white - homely light, but somewhat more neutral.



Die richtige Helligkeit

Lumen (lm) ist die standardisierte Einheit für den sogenannten Lichtstrom und lässt Rückschlüsse auf die Helligkeit einer Leuchte zu. Der Lichtstrom gibt an, wie viel Licht eine Lichtquelle abstrahlt.

Lumen (lm) is the standardised unit for the so-called luminous flux and allows conclusions to be drawn about the brightness of a luminaire. The luminous flux indicates how much light a light source emits.



Smart home - Smart light

Touch-DIM

Touch-Dim / Push-Dim - Durch kurzes Drücken eines integrierten Schalters (Push-Dim) oder des gesamten Leuchtengehäuses (Touch-Dim) wird das Licht an-/ausgeschaltet, durch ein längeres Berühren wird die Leuchte gedimmt.

Touch-Dim / Push-Dim - Briefly pressing an integrated switch (Push-Dim) or the entire luminaire housing (Touch-Dim) switches the light on/off; a longer touch dims the luminaire.

Gesten-DIM

Gesten-Dimmung - Bei der Gesten-Dimmung genügen einfache Handbewegungen vor dem Sensor, um das Licht zu steuern.

Gesture dimming - With gesture dimming, simple hand movements in front of the sensor are sufficient to control the light.

TRIAC

TRIAC - Der gebräuchlichste Dimmer in Privat-Gebäuden ist der Phasen AN/ABSchnitt-Dimmer TRIAC.

TRIAC - The most common dimmer in private buildings is the phase-cut dimmer TRIAC.

CASAMBI

CASAMBI - Lichtsteuerung erlaubt eine stufenlose Regulierung der Helligkeit via Bluetooth durch die App oder einen drahtlosen Casambi-Schalter. Überall einsetzbar, unabhängig von den technischen Gegebenheiten ist auch die Ansteuerung mehrerer Leuchten als Gruppe möglich.

CASAMBI - light control allows stepless regulation of brightness via Bluetooth through the app or a wireless Casambi switch. It can be used anywhere, regardless of the technical conditions also control of several luminaires as a group is possible.

DALI

DALI kann Leuchten oder Leuchtengruppen und sogar die Beleuchtung der ganzen Wohnung steuern, dabei können komplette Lichtszenen programmiert werden. Voraussetzung ist eine bauseitig vorhandene Gebäudesystemsteuerung.

DALI can control luminaires as well as luminaire groups, even the lighting of the entire flat, and complete lighting scenes can be programmed. The prerequisite is an existing building system control.

Bei Verwendung von DALI oder CASAMBI sind verschiedene Lichtszenen individuell programmier- und realisierbar, um verschiedene Atmosphären im Raum zu schaffen.

Using DALI or CASAMBI, different lighting scenes can be individually programmed and realised to create different atmospheres in the room.



Leuchtensteuerung über CASAMBI
Lighting control via CASAMBI

WELCOME AT HOME

DESIGN YOUR LIFE



FINO FLOOR S.50



PUSH DIM



Hochwertige Leuchten von SATTLER - eine lebenslange Freundschaft. Zeitlos und besonders. Gerade Linien, ruhige Formen, warmes Licht in der passenden Intensität. Gestalten Sie Ihre Wohlfühloase.

High-quality luminaires from SATTLER - a life-long friendship. Timeless and special. Straight lines, calm shapes, warm light with the right intensity. Design your oasis of well-being.

TABLE & FLOOR



Ob als Tisch- oder Stehleuchte, unsere mehrfach für ihr Design und Funktionalität ausgezeichneten Leuchten der **AVVENI-Serie** begeistern durch die einzigartige kugelgelagerte Verstellbarkeit des Leuchtenkopfes. In Kombination mit einer stufenlosen „PUSH-DIMMUNG“ garantieren die Leuchten ein Höchstmaß an Flexibilität.



AVVENI FLOOR 3 s.51



Whether as table or floor luminaire, our luminaires of the AVVENI series, which have won several awards for their design and functionality, inspire with the unique adjustability of the light head based on a magnetic ball joint. In combination with stepless „PUSH DIMMING“ the luminaires guarantee maximum flexibility.



Focus Open 2018
Gold



GERMAN
DESIGN
AWARD
WINNER
2017



product
design award
2017

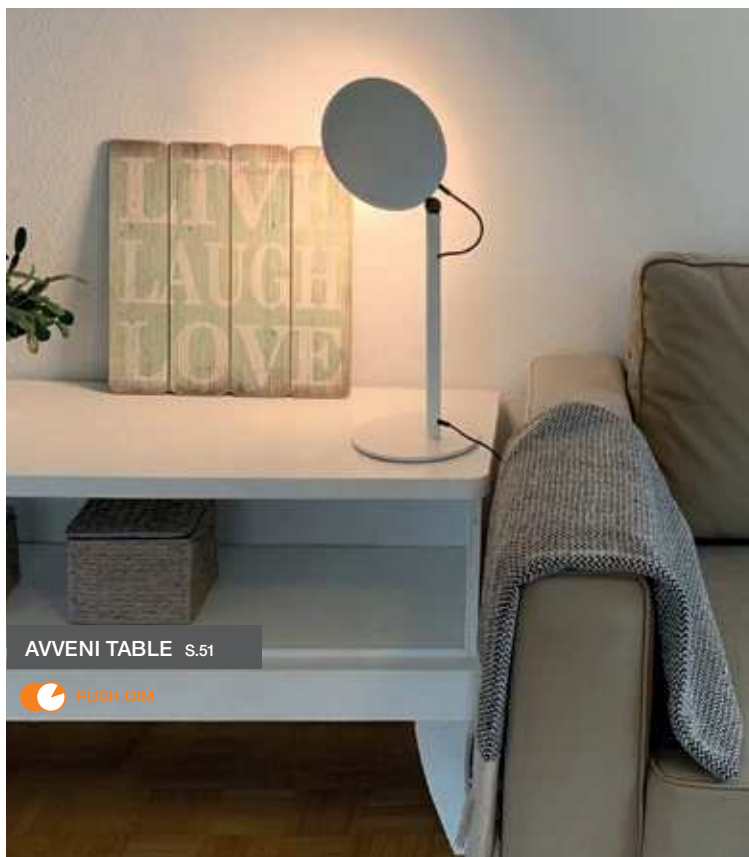

AVVENI TABLE s.51

 PUSH DIM

AVVENI FLOOR s.50

 PUSH DIM

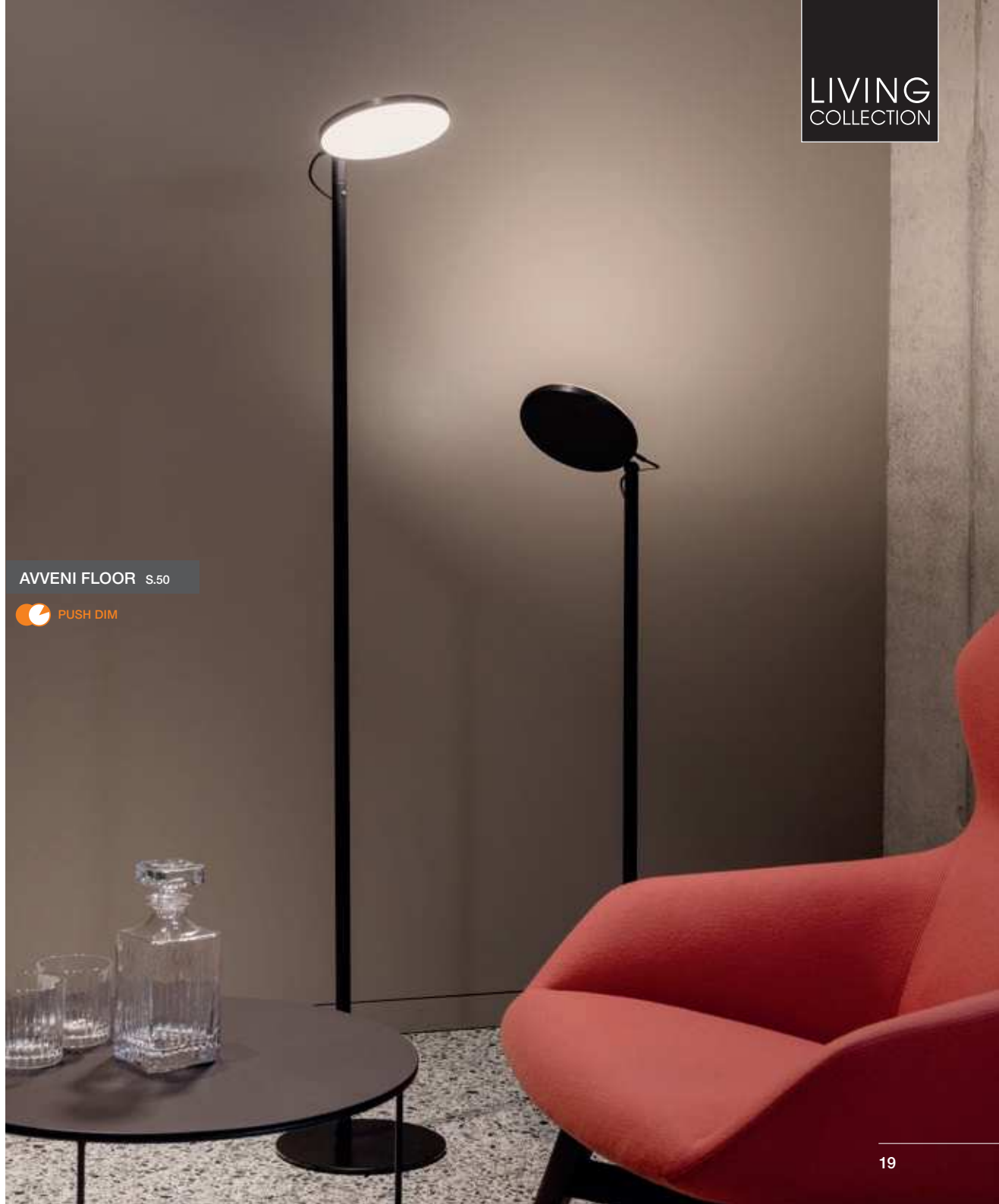

TABLE & FLOOR

Ausgefallene Designlösungen und wertige Materialien in Kombination mit modernster LED-Technik zeichnen SATTLER Leuchten aus. Licht - flexibel, elegant, individuell und besonders, wie unsere Kunden und zudem funktional. Ob massiv mit gegossenem Betonsockel oder grazil, edel mit handpolierter Oberfläche, unsere Leuchten in minimalistischer Optik sind ein Blickfang, der sich in Ihr Zuhause harmonisch einfügt.



*Gemütliche Stunden
an Ihrem Lieblingsplatz*

*Cosy hours in
your favourite place*

Unusual design solutions and high-quality materials in combination with state-of-the-art LED technology are the hallmarks of SATTLER luminaires. Light - not only functional but individual and special, like our customers. Whether solid with a cast concrete base or graceful, noble with a hand-polished surface, our luminaires with a minimalist look are eye-catchers that blend harmoniously into your home.



INSOSPESO FLOOR s.52

 TOUCH DIM

PENDELLEUCHTEN

PENDANT LUMINAIRES

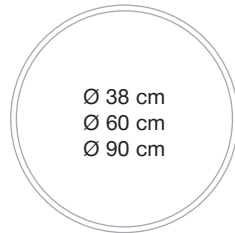

Essen in entspannter Atmosphäre, die richtige Beleuchtung setzt Ihren Tisch und Ihre Deko perfekt in Szene und schafft einen einladenden Rahmen für die gemütliche Runde in der Familie oder mit Freunden. Filigrane Pendelleuchten unserer **SLIM-Serie** in verschiedenen Größen, rund oder als Ellipse sind hierzu die elegante Wahl.

Mit einem nur 2 cm hohen Leuchtenprofil in edler Optik und der nahezu unsichtbaren Abhängung scheint die dimmbare Ringleuchte über dem Tisch zu schweben und sorgt für eine homogene Beleuchtung.



SLIM Ø 90cm s.52



Dining in a relaxed atmosphere, the right lighting sets the scene perfectly for your table and decorations and creates an inviting setting for cosy get-togethers with family or friends. Filigree pendant luminaires from our SLIM series in various sizes, round or as an ellipse are the elegant choice for this.

With a luminaire profile of only 2 cm in height and a nearly invisible suspension, the dimmable ring luminaire seems to float above the table and provides homogeneous lighting.

155 cm x 77,5 cm

SLIM ELLIPSE S.53

CASAMBI / DALI



PENDELLEUCHTEN

PENDANT LUMINAIRES



*Gemeinsam genießen mit
einer funktionalen und
formschönen Beleuchtung*

*Enjoying together with
functional and stylish lighting*

Das Licht in der Küche muss vor allem praktisch und funktional sein. Ob als Einzelleuchte oder Gruppe aus Leuchten mit unterschiedlichen Durchmessern, kombiniert mit flexiblen Spots, unsere formschönen Leuchten bringen noch mehr Spaß in die Küche. Denn die blendfreie und gute Ausleuchtung der Flächen im Arbeits- und Kochbereich lassen Sie Ihr Zuhause genießen.

The light in the kitchen must above all be practical and functional. Whether as a single luminaire or group of luminaires with different diameters, combined with flexible spots, our shapely luminaires bring even more fun into the kitchen. Because the glare-free and good illumination of the surfaces in the working and cooking area let you enjoy your home.



SLIM DIRECT Ø 60, Ø 90 cm, AVVENI Downlights with frame

PENDELLEUCHTEN

PENDANT LUMINAIRES

155 cm x 77,5 cm
220 cm x 91 cm
275 cm x 103 cm

DOPPIO ELLIPSE 220 cm x 91 cm S.54

 CASAMBI / DALI

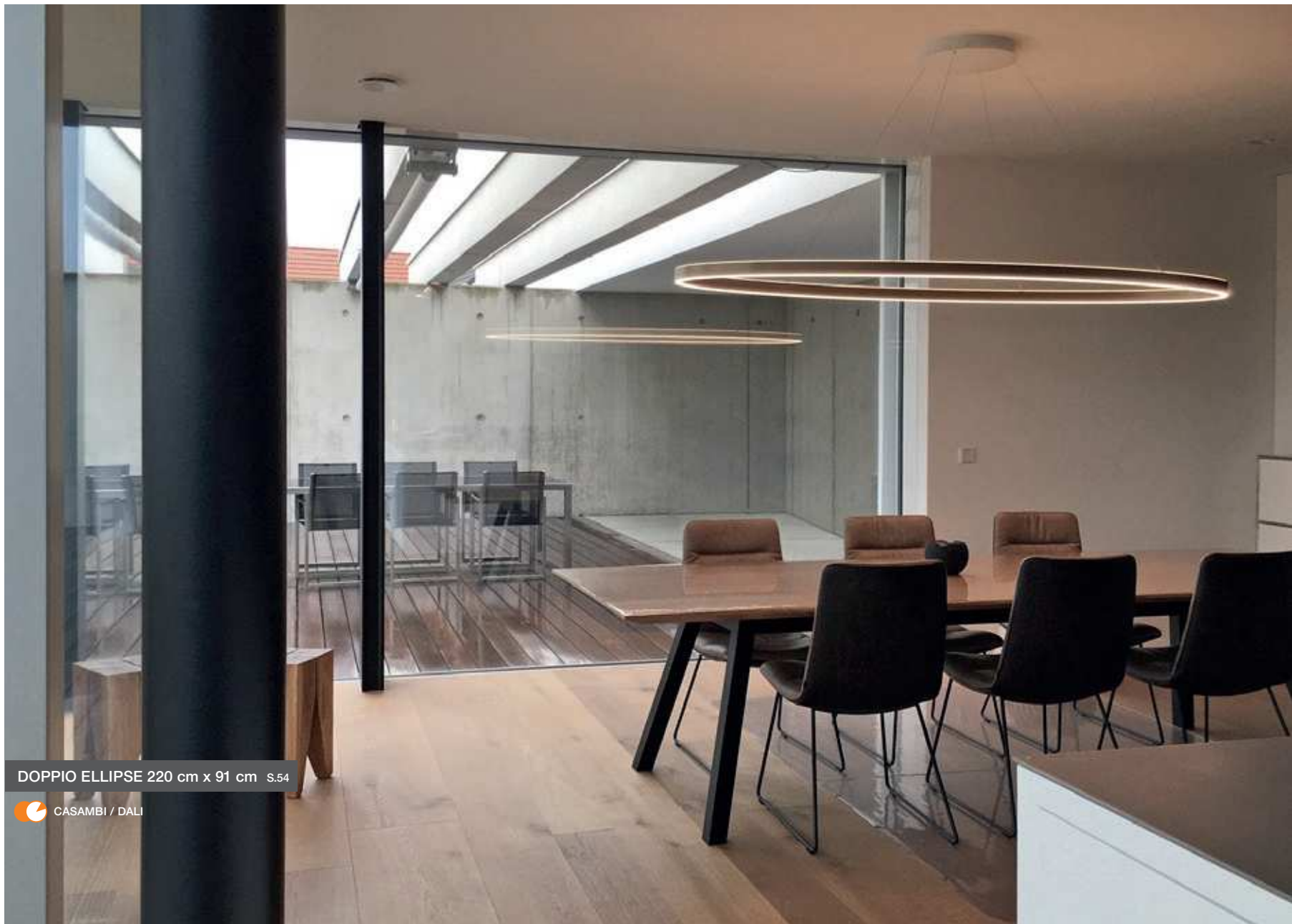



Luminaire mit indirektem Lichtanteil sind für die stimmungsvolle Wohnatmosphäre ein sehr großer Gewinn. Die Ringpendelleuchte DOPPIO ELLIPSE leuchtet direkt nach unten auf den Tisch und sorgt gleichzeitig für eine angenehme Deckenaufhellung durch den indirekten Lichtanteil. Bestimmen Sie selbst die Lichtstimmung zu jeder Tages- und Nachtzeit, denn das direkte und das indirekte Licht der DOPPIO ELLIPSE kann unabhängig voneinander geschaltet und gedimmt werden.

Luminaires with an indirect light component are a great asset for atmospheric living. The DOPPIO ELLIPSE ring pendant luminaire shines directly downwards onto the table and at the same time provides pleasant ceiling illumination thanks to the indirect light component. Determine the lighting mood yourself at any time of day or night, because direct and indirect light of the DOPPIO ELLIPSE can be switched and dimmed independently of each other.

*Indirektes Licht für
ein harmonisches Ambiente...*

*Indirect light for
a harmonious ambience...*



PENDELLEUCHTEN

PENDANT LUMINAIRES



TOCCATA Ø 90 cm s.55



TOCCATA Ø 190 cm s.55

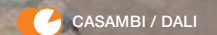

Die TOCCATA präsentiert sich als faszinierendes Lichtobjekt, das durch die raffinierte Kombination von drei oder fünf LED-Ringleuchten aus jedem Blickwinkel heraus immer wieder aufs Neue überrascht. Die besondere Kombination von nachhaltiger und handwerklicher Fertigung und modernster LED-Technologie unterstreicht diese exklusive, moderne Interpretation des klassischen Kronleuchters.

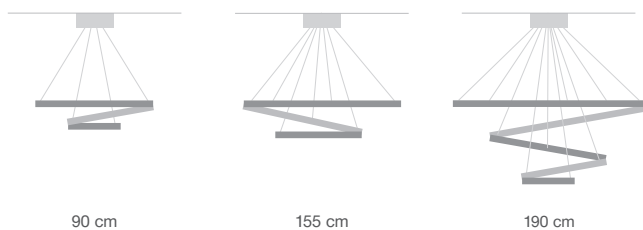

90 cm

155 cm

190 cm

Die moderne Interpretation des Kronleuchters

The modern interpretation of the chandelier

The TOCCATA presents itself as a fascinating light object that surprises again and again from every angle thanks to the sophisticated combination of three or five LED ring lights. The special combination of sustainable and handcrafted production and state-of-the-art LED technology underline this exclusive, modern interpretation of the classic chandelier.

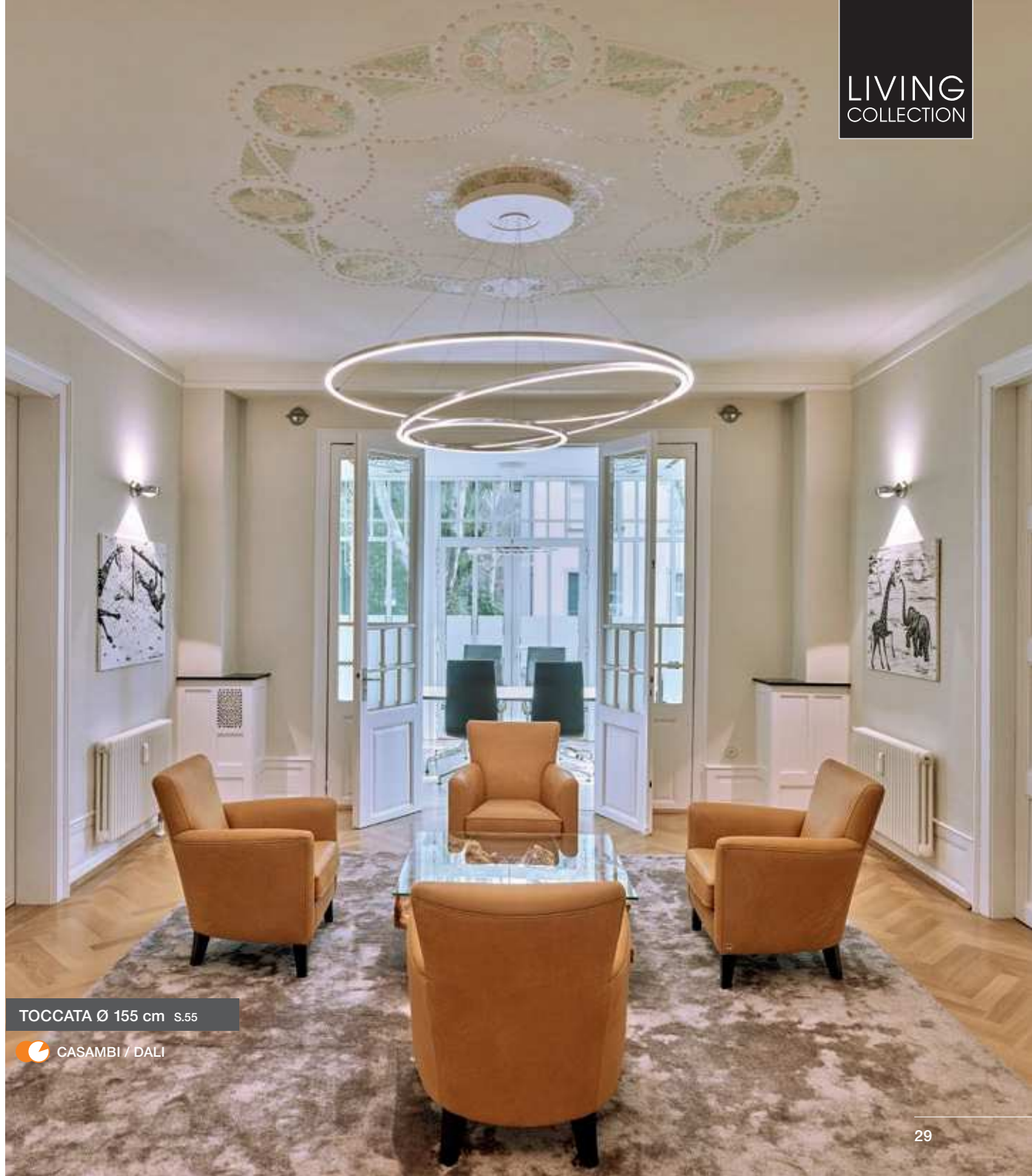

TOCCATA Ø 155 cm s.55

 CASAMBI / DALI

PALITO



Festus Open 2019



CONCORSO
DI DESIGN
APERTO
2019

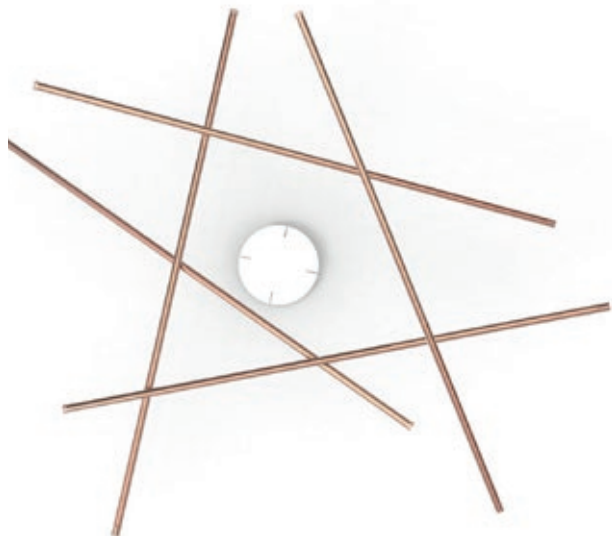

PALITO MIKADO – die spannende Unordnung sich kreuzender Linien, vereint in einer filigranen Struktur. Ausgestattet mit neuester LED-Technologie und spezieller Linsentechnik wird die PALITO MIKADO zu einem Lichtobjekt mit besonderem Reiz.

PALITO MIKADO - the intriguing disorder of intersecting lines, combined in a filigree structure. Equipped with state-of-the-art LED and special lens technology for direct and indirect light PALITO MIKADO becomes a light object with a special charm.



150 cm x 99 cm

PALITO MIKADO S.56

 DALI / CASAMBI

PENDELLEUCHTEN

PENDANT LUMINAIRES



PALITO LINEA S.57

 GESTEM DIMMUNG

PALITO LINEA in L 125 cm oder L 175 cm

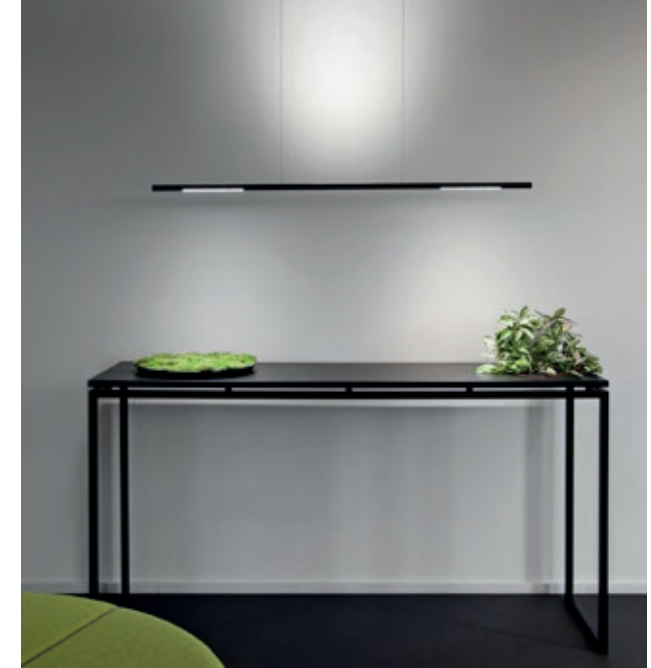

Unsere **PALITO** Serie besticht durch ihr filigranes Design. Mit einem Durchmesser von 2,2 cm und ihrem edlen eloxierten Oberflächenfinish, kombiniert mit neuester Linsentechnologie unterstützt sie perfekt Ihr modernes Wohnraumambiente. Die direkt/indirekt abstrahlende **PALITO LINEA** ist an zwei Punkten fixiert und lässt sich stufenlos verstellen. Die Gesetze der Gravitation außer Kraft zu setzen scheint die nur an einem Punkt abgependelte **PALITO**. Obwohl asymmetrisch abgependelt, schwebt sie, wenn gewünscht, ausbalanciert, waagrecht im Raum.

Our **PALITO** series impresses with its filigree design. With a diameter of 2.2 cm and its elegant anodised surface finish, combined with the latest lens technology, it perfectly supports your modern living room ambience. The direct/indirect radiating **PALITO LINEA** with direct and indirect light is fixed at two points and can continuously adjusted in height. The **PALITO**, which is suspended at only one point, seems to defy the laws of gravity. Although asymmetrically suspended, it floats horizontally in the room, if desired.



Edel im Detail - durch ein formschön integriertes Gewicht lässt sich der Neigungswinkel der Leuchte individuell einstellen.

Noble in detail - the angle of inclination of the luminaire can be individually adjusted by means of an invisibly integrated weight.



Komfortable kontaktlose Gestendimmung der PALITO Leuchte

Convenient contactless gesture control of the PALITO luminaire



PALITO S.56



GESTEN DIMMUNG

PALITO in L 124 cm oder L 155 cm



FINO PENDANT S.57

TRIAC / CASAMBI

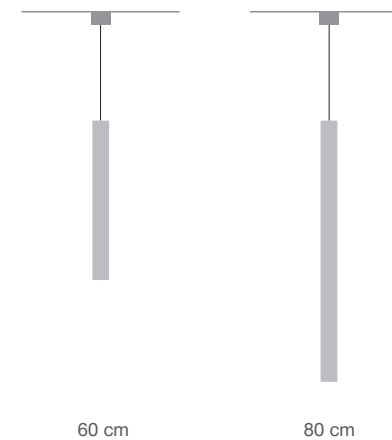

Erholung für die Sinne Relaxation for the senses

Unsere Leuchten der **PALITO** und **FINO** Serie lassen sich durch ihr baugleiches Profil mit $\varnothing 2,2$ cm und die identischen Oberflächenstrukturen perfekt kombinieren. Ob als horizontale oder vertikale Pendelleuchte, als Wandleuchte, Stehleuchte, einzeln- oder in Reihe angeordnet, das durchgängige Design bietet Ihnen kreative Kombinationsmöglichkeiten.

Our luminaires of the **PALITO** and **FINO** series can be perfectly combined thanks to the same profile with a diameter of 2.2 cm and the identical surface structures. Whether as a horizontal or vertical pendant luminaire, as a wall luminaire, floor luminaire, single or arranged in a row, the consistent design offers you creative combination possibilities.



PENDELLEUCHTEN

PENDANT LUMINAIRES



AVVENI PENDANT 1 s.59

 DALI / CASAMBI

Nie mehr kopflos! Die preisgekrönte AVVENI-Serie bietet Leuchtenköpfe mit hervorragenden Lichteigenschaften. Ob als stilvolle Einzelleuchte oder in Kombination, in Reihe oder in unterschiedlichen Höhen abgehängt, mit der **AVVENI PENDANT 1** in edler schwarz gebürsteter Optik haben Sie viele Anwendungsmöglichkeiten.

Never again headless! The award-winning AVVENI series offers light heads with outstanding lighting properties. Whether as a stylish single luminaire or in combination, suspended in a row or at different heights, with the **AVVENI PENDANT 1** in a noble black brushed look, you have many application possibilities.





Focus Open 2016



GERMAN
DESIGN
AWARD
WINNER
2017



product
design award
2017

Unsere **AVVENI PENDANT 4** mit vier flexibel beweglichen, auf einem Kugelgelenk gelagerten Leuchtenköpfen, dezenter Abhängung und integrierter Stromführung. Spannende, asymmetrische Formgebung und individuell wählbare Oberflächen bieten kreativen Spielraum. Platziert über Tischflächen oder Theken, im Wohn-, Esszimmer oder in der Küche wird sie zum attraktiven Blickfang. Ideal auch in Kombination mit anderen Leuchten unserer AVVENI-Serie.

Our **AVVENI PENDANT 4** with four flexibly movable light heads mounted on a ball joint, discreet suspension and integrated power supply. Exciting, asymmetrical design and selectable surface finishes offer creative scope. Placed above tables or counters, in the living room, dining room or kitchen, it becomes an attractive eye-catcher. Also ideal in combination with other luminaires from our AVVENI series.



AVVENI PENDANT 4 s.59

DALI / CASABE

LINEARE LEUCHTEN

LINEAR LUMINAIRES

DOPPIO LINEA

127 cm | 152 cm | 212 cm

Sie suchen die passende Beleuchtung für Ihren Home-Office Arbeitsplatz, Ihre Küchentheke oder Ihren Esszimmertisch? Unsere Auswahl an linearen Leuchten in verschiedensten Längen, hochwertigen Eloxaloberflächen, mit direkter und zusätzlich indirekter Beleuchtung ausgestattet und mit blendfreier LED Technologie, werden Ihren individuellen Anforderungen sicher entsprechen.



DOPPIO LINEA s.60

 DALI / CASAMBI / TRIAC



PALADIO LENS

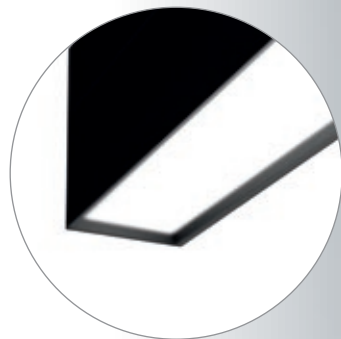

PALADIO OPAL

Die optimale Beleuchtung für Ihr Home-Office
The optimal lighting for your home office

PALADIO 35 OPAL

Pendelleuchte 141 cm | 169 cm

PALADIO 35 LENS (blendfrei/ glare-free)

Pendelleuchte 141 cm | 169 cm | 225 cm | 281 cm

Anbauleuchte 141 cm | 169 cm | 225 cm | 281 cm



Are you looking for the right lighting for your home office workstation, your kitchen counter or your dining room table? Our selection of linear luminaires in a wide range of lengths, high-quality anodised surfaces, with direct and additionally indirect light, equipped with glare-free LED technology will certainly meet your individual requirements.



PALADIO 35 OPAL s.61

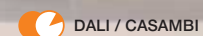

LINEARE STROMSCHIENE 48V

LINEAR POWER TRACK 48V



PALADIO TRACK 35 S.64

3 x AVVENI PENDANT 1
4 x EVOLUTION SPOT

 DALI / CASAMBI

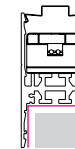

AVVENI PENDANT 1 an PALADIO TRACK 35 S.64

 DALI / CASAMBI

169 cm | 225 cm | 281 cm

Was für eine schicke Lösung: Mehrere Pendelleuchten strahlen als dekoratives Ensemble auf Ihren Esstisch und verwandeln ihn in eine gemütliche Lichtoase. Aber es ist nur ein Deckenauslass vorhanden? Kein Problem: Mit unserer PALADIO TRACK 35 Stromschiene lässt sich dieses Dilemma ganz einfach beheben. Diese lässt sich kinderleicht an nur einem Auslass installieren und erlaubt den Anschluss mehrerer Pendelleuchten oder Spots, die flexibel, auch kombiniert angeordnet werden können.



PALADIO TRACK 35 s.64

 DALI / CASAMBI



FINO PENDANT an PALADIO TRACK 35 s.64

 DALI / CASAMBI



EVOLUTION SPOT an PALADIO TRACK 35 s.64

 DALI / CASAMBI

What a chic solution: several pendant luminaires shine as a decorative ensemble on your dining table and transform it into a cosy oasis of light. But there is only one ceiling outlet? No problem: with our PALADIO TRACK 35 power track, this dilemma can be solved very easily. It is very simple to install on just one outlet and it allows the connection of several pendant luminaires or spots, which can be arranged flexibly, even in combination.

SPOT



EVOLUTION SPOT an PALADIO TRACK s.65



EVOLUTION SPOT s.65



Spot on! Setzen Sie Ihr Kunstwerk in Szene! Oder nutzen Sie das volle Potenzial der Lichtwirkung im Raum aus und richten den Strahler auf eine Reflexionsfläche. Solche bewusst gesetzten Lichtkegel sorgen aufgrund der Wandreflexion dafür, dass der Raum größer und heller wirkt. Strahler unserer **EVOLUTION** und **AVVENI** Serien sind sowohl für den Decken- als auch den Wandanbau geeignet.

Spot on! Set the scene for your work of art! Or use the full potential of the lighting effect in the room and direct the spotlight onto a reflective surface. Such deliberately placed light beams ensure that the room appears larger and brighter due to the wall reflection. Spotlights from our **EVOLUTION** and **AVVENI** series are suitable for both ceiling and wall mounting.

AVVENI SINGLE S.66

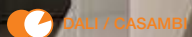

WAND & DECKE

WALL & CEILING



SPOTS: Das Licht zum Hinsehen, hebt einzelne Segmente oder Objekte hervor, indem die akzentuierte Lichtstärke höher ist als die Raumbelichtung. Somit können Sie mit Ihren Decken- oder Wandstrahlern den Blick bewusst auf Besonderheiten in Ihrer Wohnung lenken.

Ob Kunst, Deko, Pflanzen oder Arbeitsbereiche, unsere sehr flexibel einstellbaren, dimmbaren Strahler setzen Interessantes gekonnt in Szene.



AVVENI SINGLE S.66



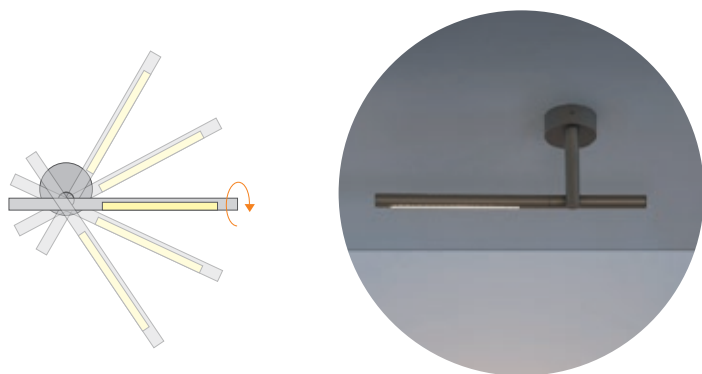

SPOTS: The light to direct attention, emphasises individual segments or objects by the accentuated light intensity being higher than the room lighting. In this way, you can use your ceiling or wall spotlights to consciously direct the view to special features in your home.

Whether art, decoration, plants or work areas, our very flexibly adjustable, dimmable spotlights skilfully set the scene for interesting objects.



PALITO WALL s.65



TREPPENHAUS UND EINGANGSBEREICH

STAIRCASE AND ENTRANCE AREA

Der Eingangsbereich ist das Aushängeschild, der erste Eindruck Ihres Zuhauses. Er verdient daher auch bei der Lichtplanung ein besonderes Augenmerk, damit sich Ihre Gäste von Anfang an willkommen fühlen. Mit Leuchten von SATTLER sorgen Sie auch in diesem Bereich für ein wohntoniges Ambiente und einen strahlenden Empfang. Hier zeigen wir Ihnen eine Auswahl an repräsentativen Pendelleuchten, die sowohl im Eingangs- als auch im Treppenhausbereich großzügige Akzente setzen. Je nach Leuchte haben Sie die Möglichkeit, auch größere Raumhöhen perfekt auszunutzen. Durch die nahezu unsichtbare, variable Abhängung der Leuchte schweben die Leuchten im Raum. Ob direkte Beleuchtung oder Leuchten mit zusätzlichem indirektem Licht, Sie finden in unserem Gesamtportfolio die für Ihre Ansprüche passende Leuchte.

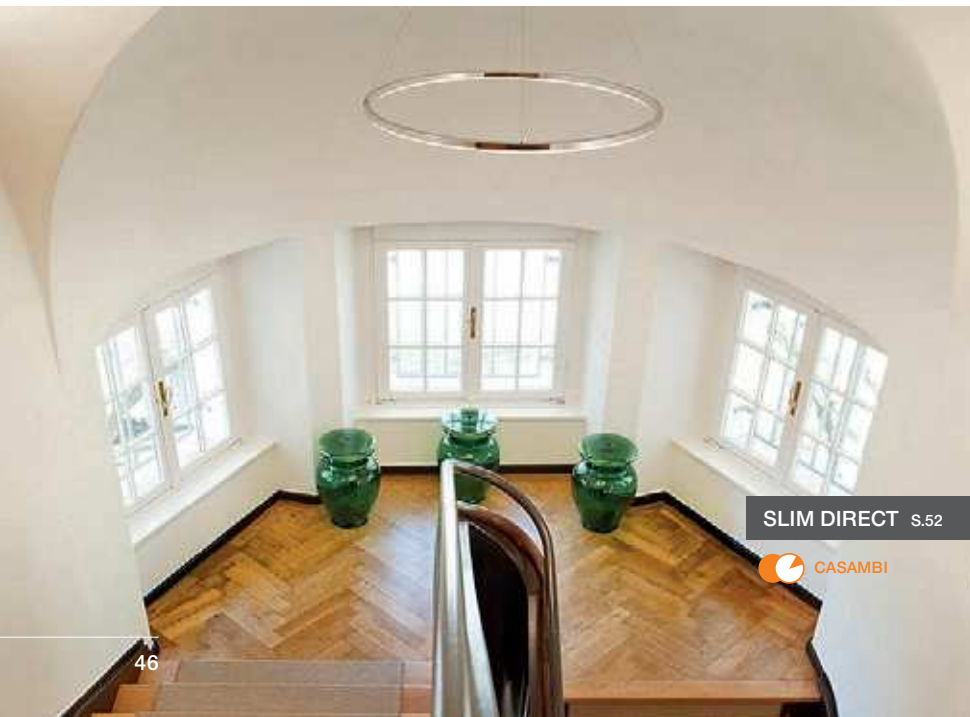

SLIM DIRECT s.52



TOCCATA s.55





AVVENI VERTICAL 4

The entrance area is the figurehead, the first impression of your home. It therefore deserves special attention in the lighting design so that your guests feel welcome right from the start. With luminaires from SATTLER, you can create a homely ambience and a radiant welcome in this area as well. Here we show you a selection of representative pendant luminaires that set generous accents in the entrance area as well as in the staircase area. Depending on the luminaire, you also have the option of making perfect use of larger room heights. Thanks to the almost invisible, variable suspension of the luminaire, the luminaires float in the room. Whether direct lighting or luminaires with additional indirect light, you will find the right luminaire in our total portfolio.



EVOLUTION

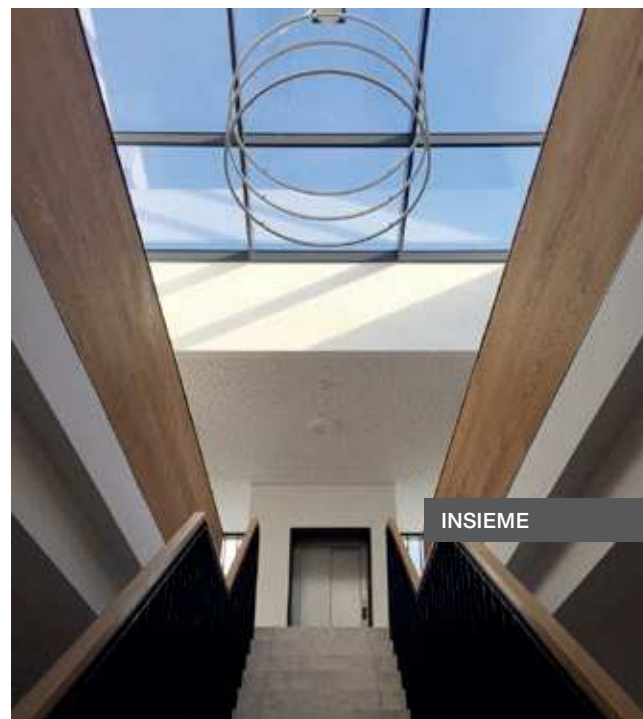

INSIEME



DOPPIO



FULL OF ENERGY

ENJOY THE LIGHT

An sonnigen Tagen steigt unser Wohlbefinden. Wir sind gut gelaunt und voller Energie – natürliches Licht beflügelt uns. Mit SATTLER Leuchten holen Sie sich dieses Gefühl mit nachhaltiger Beleuchtung zum Wohlfühlen in Ihr Zuhause.

On sunny days, our well-being increases. We are in a good mood and full of energy - natural light inspires us. With SATTLER luminaires, you can bring this feeling into your home with sustainable lighting that makes you feel good.

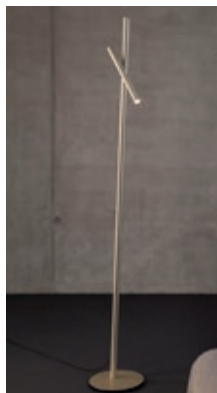

FINO FLOOR H 130 cm

H (max.) x Ø Fuß Profil [cm] H (max.) x Ø base profile	LED Watt	Lumen	Gewicht [kg] weight	Lichtfarbe light colour	Dimmung dimming	Art. Nr. Art. No.	Farbe colour
130 x 20 2,2 cm	4	313	2,5	2700 K	PUSH DIM	1537. 27. 07. 00.	--- Z80. N



WEBSITE

Farbe Leuchte / Colour luminaire --- =

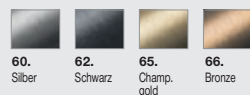

Farbübersicht siehe Seite 67 / Colour chart see page 67

3000 K PUSH DIM **1537. 30. 07. 00.** --- Z80. N

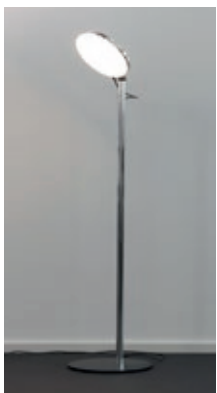

AVVENI FLOOR H 126 cm, Leuchtenkopf (Flood) / Light head (Flood)

H (max.) x Ø Fuß Kopf [cm] H (max.) x Ø base light head	LED Watt	Lumen	Gewicht [kg] weight	Lichtfarbe light colour	Dimmung dimming	Art. Nr. Struktur Art. No. structure	Art. Nr. Leuchtenkopf Art. No. light head
126 x 25 19,6	17	1.344	4,5	2700 K	PUSH DIM	1105. --- 07. 90. 0N	01. --- --- 27. 99. 00. 00



WEBSITE

Farbe Fuß | Struktur / Colour base | structure --- =

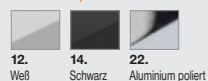

Farbe Ring + Farbe Abdeckung / colour ring + colour cover _

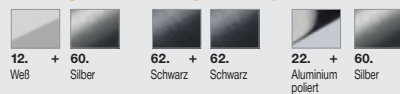

Farbübersicht siehe Seite 67 / Colour chart see page 67

* wenn Struktur Aluminium poliert (22) – Fuß schwarz (14)
if structure aluminium polished (22) - base black (14)

3000 K PUSH DIM **1105. --- 07. 90. 0N** 01. --- --- **30. 99. 00. 00**

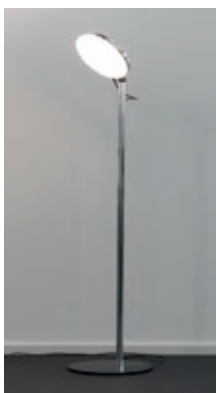

AVVENI FLOOR H 176 cm, Leuchtenkopf (Flood) / Light head (Flood)

H (max.) x Ø Fuß Kopf [cm] H (max.) x Ø base light head	LED Watt	Lumen	Gewicht [kg] weight	Lichtfarbe light colour	Dimmung dimming	Art. Nr. Struktur Art. No. structure	Art. Nr. Leuchtenkopf Art. No. light head
176 x 25 19,6	17	1.344	4,8	2700 K	PUSH DIM	1106. --- 07. 90. 0N	01. --- --- 27. 99. 00. 00



WEBSITE

Farbe Fuß | Struktur / Colour base | structure --- =

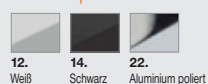

Farbe Ring + Farbe Abdeckung / colour ring + colour cover --- =

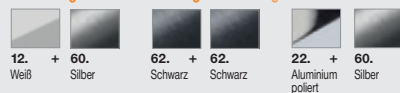

Farbübersicht siehe Seite 67 / Colour chart see page 67

* wenn Struktur Aluminium poliert (22) – Fuß schwarz (14)
if structure aluminium polished (22) - base black (14)

3000 K PUSH DIM **1106. --- 07. 90. 0N** 01. --- --- **30. 99. 00. 00**

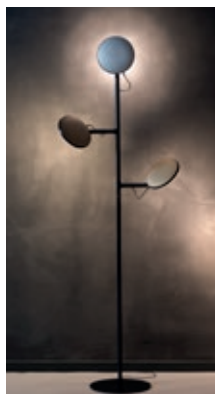

AVENI FLOOR 3 H 182 cm, drei Leuchtenköpfe (Flood) / Three light heads (Flood)

H (max.) x Ø Fuß Kopf [cm] H (max.) x Ø base light head	LED Watt	Lumen	Gewicht [kg] weight	Lichtfarbe light colour	Dimmung dimming	Art. Nr. Struktur Art. No. structure	Art. Nr. Leuchtenkopf Art. No. light head
182 x 32 19,6	3 x 17	3 x 1.344	7,2	2700 K	PUSH DIM	1110. -.-. 07. 90. 0N	01. -.-. -.-. 27. 99. 00. 00



WEBSITE

Farbe Fuß | Struktur / Colour base | structure -.-. =

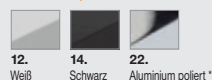

Farbe Ring + Farbe Abdeckung / colour ring + colour cover

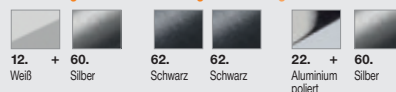

Farbübersicht siehe Seite 67 / Colour chart see page 67

3000 K PUSH DIM **1110.** -.-. 07. 90. 0N 01. -.-. -.-. **30. 99. 00. 00**

* wenn Struktur Aluminium poliert (22) – Fuß schwarz (14)
if structure aluminium polished (22) - base black (14)

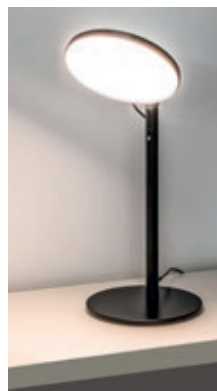

AVENI TABLE H 56 cm, Leuchtenkopf (Flood) / Light head (Flood)

H (max.) x Ø Fuß Kopf [cm] H (max.) x Ø base light head	LED Watt	Lumen	Gewicht [kg] weight	Lichtfarbe light colour	Dimmung dimming	Art. Nr. Struktur Art. No. structure	Art. Nr. Leuchtenkopf Art. No. light head
56 x 20 19,6	17	1.344	2,0	2700 K	PUSH DIM	1100. -.-. 07. 90. 0N	01. -.-. -.-. 27. 99. 00. 00



WEBSITE

Farbe Fuß | Struktur / Colour base | structure -.-. =

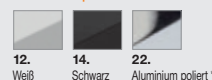

Farbe Ring + Farbe Abdeckung / colour ring + colour cover -.-. -.-. =

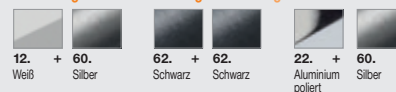

Farbübersicht siehe Seite 67 / Colour chart see page 67

3000 K PUSH DIM **1100.** -.-. 07. 90. 0N 01. -.-. -.-. **30. 99. 00. 00**

* wenn Struktur Aluminium poliert (22) – Fuß schwarz (14)
if structure aluminium polished (22) - base black (14)



AVENI CONCRETE Leuchtenkopf (Flood) / Light head (Flood)

H x Ø Fuß Kopf [cm] H x Ø base light head	LED Watt	Lumen	Gewicht [kg] weight	Lichtfarbe light colour	Dimmung dimming	Art. Nr. Struktur Art. No. structure	Art. Nr. Leuchtenkopf Art. No. light head
31,5 x 8,8 19,6	17	1.344	2,0	2700 K	CASAMBI	1155. 00. 08. 90. 0N	01. -.-. -.-. 27. 99. 00. 00



WEBSITE

Farbe Ring + Farbe Abdeckung / colour ring + colour cover -.-. -.-. =



Farbübersicht siehe Seite 67 / Colour chart see page 67

3000 K CASAMBI **1155.** 00. 08. 90. 0N 01. -.-. -.-. **30. 99. 00. 00**



SLIM TABLE Ø 38 cm

Ø Leuchte [cm] Ø lumiere	LED Watt	Lumen	Gewicht [kg] weight	Lichtfarbe light colour	Dimmung dimming	Art. Nr. Art. No.	Farbe colour
38	14	897	1,0	2700 K	TOUCH DIM	737. 27. 21. 00.	--- Z90. L
				3000 K	TOUCH DIM	737. 30. 21. 00.	--- Z90. L



WEBSITE

Farbe Leuchte / Colour luminaire --- =

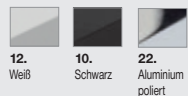

Farbübersicht siehe Seite 67 / Colour chart see page 67

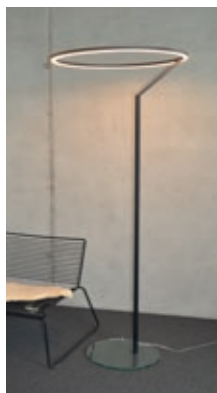

INSOSPESO FLOOR H 190 cm

H (max.) x Ø Fuß H (max.) x Ø base	Kopf [cm] head	LED Watt	Lumen	Gewicht [kg] weight	Lichtfarbe light colour	Dimmung dimming	Art. Nr. Art. No.	Farbe colour
190 x 40 70		43	2.509	7,0	2700 K	TOUCH DIM	597. 27. 21. 00.	--- Z91. N
					3000 K	TOUCH DIM	597. 30. 21. 00.	--- Z91. N



WEBSITE

Farbe Leuchte / Colour luminaire --- =

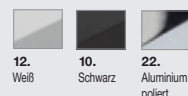

Farbübersicht siehe Seite 67 / Colour chart see page 67



SLIM DIRECT Ø 38 cm, mit Baldachin / with canopy

Ø x H Profil [cm] Ø x H profile	LED Watt	Lumen	Gewicht [kg] weight	Lichtfarbe light colour	Dimmung dimming	Art. Nr. Art. No.	Farbe colour
38 x 2	22	1.269	2,5	3000 K	CASAMBI	709. 30. 81. 00.	--- 000. F
				2700 - 6500 K tunable white	CASAMBI	709. 80. 81. 00.	--- 000. F



WEBSITE

Farbe Leuchte / Colour luminaire --- =



Farbübersicht siehe Seite 67 / Colour chart see page 67

Mit dezenter Stahlseilabhängung und integrierter Stromführung.
Discreet suspension with current-carrying steel cables.

SLIM DIRECT Ø 60 cm, mit Baldachin / with canopy

Ø x H Profil [cm] Ø x H profile	LED Watt	Lumen	Gewicht [kg] weight	Lichtfarbe light colour	Dimmung dimming	Art. Nr. Art. No.	Farbe colour
60 x 2	32	2.192	3,0	2700 K	CASAMBI	710. 27. 81. 00.	-- 000. F
				3000 K	CASAMBI	710. 30. 81. 00.	-- 000. F
				2700 - 6500 K tunable white	CASAMBI	710. 80. 81. 00.	-- 000. F



WEBSITE

Farbe Leuchte / Colour luminaire -- =

Farbübersicht siehe Seite 67 / Colour chart see page 67

 Mit dezenter Stahlseilabhängung und integrierter Stromführung.
Discreet suspension with current-carrying steel cables.

SLIM DIRECT Ø 90 cm, mit Baldachin / with canopy

Ø x H Profil [cm] Ø x H profile	LED Watt	Lumen	Gewicht [kg] weight	Lichtfarbe light colour	Dimmung dimming	Art. Nr. Art. No.	Farbe colour
90 x 2	54	3.196	3,5	2700 K	CASAMBI	711. 27. 81. 00.	-- 000. F
				3000 K	CASAMBI	711. 30. 81. 00.	-- 000. F
				2700 - 6500 K tunable white	CASAMBI	711. 80. 81. 00.	-- 000. F

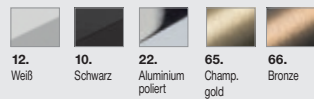

WEBSITE

Farbe Leuchte / Colour luminaire -- =

Farbübersicht siehe Seite 67 / Colour chart see page 67

 Mit dezenter Stahlseilabhängung und integrierter Stromführung.
Discreet suspension with current-carrying steel cables.

SLIM ELLIPSE DIRECT 155 x 77,5 x 2 cm, mit Baldachin / with canopy

L x B x H Profil [cm] L x W x H profile	LED Watt	Lumen	Gewicht [kg] weight	Lichtfarbe light colour	Dimmung dimming	Art. Nr. Art. No.	Farbe colour
155 x 77,5 x 2	70	4.107	6	2700 K	CASAMBI	738. 27. 81. 00.	-- 000. F
				3000 K	CASAMBI	738. 30. 81. 00.	-- 000. F
				2700 K	DALI	738. 27. 61. 00.	-- 000. F
				3000 K	DALI	738. 30. 61. 00.	-- 000. F





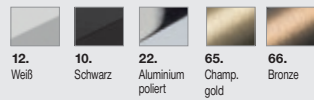

WEBSITE

Farbe Leuchte / Colour luminaire -- =

Farbübersicht siehe Seite 67 / Colour chart see page 67

 Mit dezenter Stahlseilabhängung und integrierter Stromführung.
Discreet suspension with current-carrying steel cables.

DOPPIO ELLIPSE 155 x 77,5 x 4,6 cm, direkt/indirekt, mit Baldachin / direct/indirect, with canopy





L x B x H Profil [cm] L x W x H profile	LED Watt	Lumen	Gewicht [kg] weight	Lichtfarbe light colour	Dimmung dimming	Art. Nr. Art. No.	Farbe colour	
155 x 77,5 x 4,6	70 / 26	4.107 / 1.519	6	2700 K	CASAMBI	1091. 27. 82. 27.	--- 000. F	
	Farbe Leuchte / Colour luminaire --- =			3000 K	CASAMBI	1091. 30. 82. 30.	--- 000. F	
					2700 K	DALI	1091. 27. 62. 27.	--- 000. F
	12. Weiß	10. Schwarz	22. Aluminium poliert	65. Champ. gold	3000 K	DALI	1091 30. 62. 30.	--- 000. F
				66. Bronze gebürstet				

WEBSITE

Farbübersicht siehe Seite 67 / Colour chart see page 67

Direkt und indirekt leuchtend, mit dezenter Stahlseilabhängung und integrierter Stromführung.
Direct and indirect lighting, discreet suspension with current-carrying steel cables.

DOPPIO ELLIPSE 220 x 91 x 4,6 cm, direkt/indirekt, mit Baldachin / direct/indirect, with canopy





L x B x H Profil [cm] L x W x H profile	LED Watt	Lumen	Gewicht [kg] weight	Lichtfarbe light colour	Dimmung dimming	Art. Nr. Art. No.	Farbe colour	
220 x 91 x 4,6	89 / 37	5.241 / 2.136	7	2700 K	CASAMBI	1092. 27. 82. 27.	--- 000. F	
	Farbe Leuchte / Colour luminaire --- =			3000 K	CASAMBI	1092. 30. 82. 30.	--- 000. F	
					2700 K	DALI	1092. 27. 62. 27.	--- 000. F
	12. Weiß	10. Schwarz	22. Aluminium poliert	65. Champ. gold	3000 K	DALI	1092 30. 62. 30.	--- 000. F
				66. Bronze gebürstet				

WEBSITE

Farbübersicht siehe Seite 67 / Colour chart see page 67

Direkt und indirekt leuchtend, mit dezenter Stahlseilabhängung und integrierter Stromführung.
Direct and indirect lighting, discreet suspension with current-carrying steel cables.

DOPPIO ELLIPSE 275 x 103 x 4,6 cm, direkt/indirekt, mit Baldachin / direct/indirect, with canopy

L x B x H Profil [cm] L x W x H profile	LED Watt	Lumen	Gewicht [kg] weight	Lichtfarbe light colour	Dimmung dimming	Art. Nr. Art. No.	Farbe colour	
275 x 103 x 4,6	115 / 50	6.812 / 2.935	9	2700 K	CASAMBI	1093. 27. 82. 27.	--- 000. F	
	Farbe Leuchte / Colour luminaire --- =			3000 K	CASAMBI	1093. 30. 82. 30.	--- 000. F	
					2700 K	DALI	1093. 27. 62. 27.	--- 000. F
	12. Weiß	10. Schwarz	22. Aluminium poliert	65. Champ. gold	3000 K	DALI	1093 30. 62. 30.	--- 000. F
				66. Bronze gebürstet				

WEBSITE





Farbübersicht siehe Seite 67 / Colour chart see page 67

Direkt und indirekt leuchtend, mit dezenter Stahlseilabhängung und integrierter Stromführung.
Direct and indirect lighting, discreet suspension with current-carrying steel cables.





TOCCATA 90 cm, mit Baldachin / with canopy





Ø x H (Leuchte Profil) [cm] Ø x H (lumiere profile)	LED Watt	Lumen	Gewicht [kg] weight	Lichtfarbe light colour	Dimmung dimming	Art. Nr. Art. No.	Farbe colour
90 70 38 x 12,8 2	83	4.840	8,0	2700 K	CASAMBI	777. 27. 81. 00.	--- 000. F
 WEBSITE	Farbe Leuchte / Colour luminaire --- =  12. Weiß  10. Schwarz  22. Aluminium poliert		3000 K	CASAMBI	777. 30. 81. 00.	--- 000. F	
	2700 K	DALI	777. 27. 61. 00.	--- 000. F			
	3000 K	DALI	777. 30. 61. 00.	--- 000. F			

Farbübersicht siehe Seite 67 / Colour chart see page 67

Mit dezenter Stahlseilabhängung und integrierter Stromführung / Discreet suspension with current-carrying steel cables.



TOCCATA Ø 155 cm, mit Baldachin / with canopy





Ø x H (Leuchte Profil) [cm] Ø x H (lumiere profile)	LED Watt	Lumen	Gewicht [kg] weight	Lichtfarbe light colour	Dimmung dimming	Art. Nr. Art. No.	Farbe colour
155 124 70 x 30 2	143	8.291	11,0	2700 K	CASAMBI	771. 27. 81. 00.	--- 000. J
 WEBSITE	Farbe Leuchte / Colour luminaire --- =  12. Weiß  10. Schwarz  22. Aluminium poliert		3000 K	CASAMBI	771. 30. 81. 00.	--- 000. J	
	2700 K	DALI	771. 27. 61. 00.	--- 000. J			
	3000 K	DALI	771. 30. 61. 00.	--- 000. J			

Farbübersicht siehe Seite 67 / Colour chart see page 67

Mit dezenter Stahlseilabhängung und integrierter Stromführung / Discreet suspension with current-carrying steel cables.



TOCCATA Ø 190 cm, mit Baldachin / with canopy

Ø x H (Leuchte Profil) [cm] Ø x H (lumiere profile)	LED Watt	Lumen	Gewicht [kg] weight	Lichtfarbe light colour	Dimmung dimming	Art. Nr. Art. No.	Farbe colour
190 155 124 90 60 x 45 2	248	14.580	14,0	2700 K	CASAMBI	773. 27. 81. 00.	--- 000. I
 WEBSITE	Farbe Leuchte / Colour luminaire --- =  12. Weiß  10. Schwarz  22. Aluminium poliert		3000 K	CASAMBI	773. 30. 81. 00.	--- 000. I	
	2700 K	DALI	773. 27. 61. 00.	--- 000. I			
	3000 K	DALI	773. 30. 61. 00.	--- 000. I			

Farbübersicht siehe Seite 67 / Colour chart see page 67

Mit dezenter Stahlseilabhängung und integrierter Stromführung / Discreet suspension with current-carrying steel cables.

PALITO MIKADO 150 x 99 x 19 cm, mit Deckenbaldachin / with canopy

L x B x H Ø Profil [cm] L x W x H Ø profile	LED Watt	Lumen	Gewicht [kg] weight	Lichtfarbe light colour	Dimmung dimming	Art. Nr. Art. No.	Farbe colour
150 x 99 x 19 2,2	58	7.040	3,5	2700 K	DALI	1543. 27. 61. 27.	--- 000. F

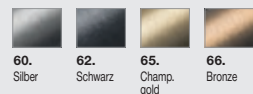

WEBSITE

Farbe Leuchte / Colour luminaire --- =

Farbübersicht siehe Seite 67 / Colour chart see page 67

3000 K	DALI	1543. 30. 61. 30.	--- 000. F
2700 K	CASAMBI	1543. 27. 81. 27.	--- 000. F
3000 K	CASAMBI	1543. 30. 81. 30.	--- 000. F

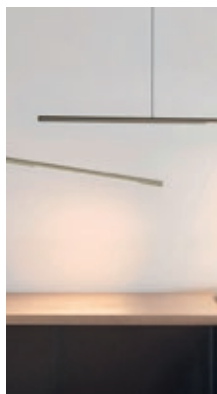
 Direkt und indirekt leuchtend, mit dezenter Stahlseilabhängung und integrierter Stromführung.
 Direct and indirect lighting, discreet suspension with current-carrying steel cables.

PALITO L 124 cm, mit Deckenbaldachin / with canopy

L x Ø Profil [cm] L x Ø profile	LED Watt	Lumen	Gewicht [kg] weight	Lichtfarbe light colour	Dimmung dimming	Art. Nr. Art. No.	Farbe colour
124 x 2,2	10	1.385	1,4	2700 K	Gestendimmung gesture dimming	1541. 27. 21. 00.	--- Z80. F

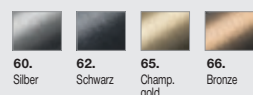

WEBSITE

Farbe Leuchte / Colour luminaire --- =

Farbübersicht siehe Seite 67 / Colour chart see page 67

3000 K	Gestendimmung gesture dimming	1541. 30. 21. 00.	--- Z80. F
---------------	----------------------------------	--------------------------	------------

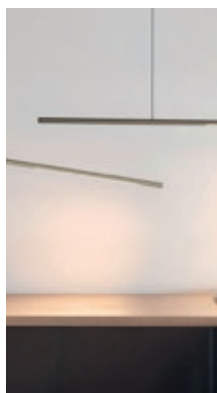
 Neigungswinkel beliebig verstellbar.
 Angle of inclination can be adjusted as required.

PALITO L 155 cm, mit Deckenbaldachin / with canopy

L x Ø Profil [cm] L x Ø profile	LED Watt	Lumen	Gewicht [kg] weight	Lichtfarbe light colour	Dimmung dimming	Art. Nr. Art. No.	Farbe colour
155 x 2,2	15	2.080	2,0	2700 K	Gestendimmung gesture dimming	1542. 27. 21. 00.	--- Z80. F

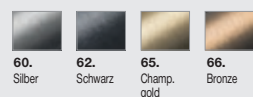

WEBSITE

Farbe Leuchte / Colour luminaire --- =

Farbübersicht siehe Seite 67 / Colour chart see page 67

3000 K	Gestendimmung gesture dimming	1542. 30. 21. 00.	--- Z80. F
---------------	----------------------------------	--------------------------	------------

 Neigungswinkel beliebig verstellbar.
 Angle of inclination can be adjusted as required.



PALITO LINEA L 125 cm, direkt/indirekt, mit Deckenbaldachin, höhenverstellbar / direct/indirect, with canopy, height adjustable

L x Ø Profil [cm] L x Ø profile	LED Watt	Lumen	Gewicht [kg] weight	Lichtfarbe light colour	Dimmung dimming	Art. Nr. Art. No.	Farbe colour
125 x 2,2	10 / 5	1.260 / 630	2,3	2700 - 6500 K tunable white	Gestendimmung gesture dimming	1545. 80. 21. 80. --- 000. Y	



WEBSITE

Farbe Leuchte / Colour luminaire --- =

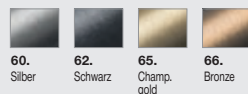

Farbübersicht siehe Seite 67 / Colour chart see page 67

Direkt und indirekt leuchtend, mit dezenter Stahlseilabhängung und integrierter Stromführung.
Direct and indirect lighting, discreet suspension with current-carrying steel cables.



PALITO LINEA L 175 cm, direkt/indirekt, mit Deckenbaldachin, höhenverstellbar / direct/indirect, with canopy, height adjustable

L x Ø Profil [cm] L x Ø profile	LED Watt	Lumen	Gewicht [kg] weight	Lichtfarbe light colour	Dimmung dimming	Art. Nr. Art. No.	Farbe colour
175 x 2,2	20 / 5	2.520 / 630	3,2	2700 - 6500 K tunable white	Gestendimmung gesture dimming	1546. 80. 21. 80. --- 000. Y	



WEBSITE

Farbe Leuchte / Colour luminaire --- =

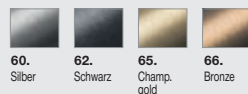

Farbübersicht siehe Seite 67 / Colour chart see page 67

Direkt und indirekt leuchtend, mit dezenter Stahlseilabhängung und integrierter Stromführung.
Direct and indirect lighting, discreet suspension with current-carrying steel cables.



FINO PENDANT L 60 cm, mit Deckenbaldachin / with canopy

L x Ø Baldachin Profil [cm] L x Ø canopy profile	LED Watt	Lumen	Gewicht [kg] weight	Lichtfarbe light colour	Dimmung dimming	Art. Nr. Art. No.	Farbe colour
60 x 7,8 2,2	5	365	0,4	2700 K	TRIAC	1533. 27. 11. 00. --- Z80. F	
				3000 K	TRIAC	1533. 30. 11. 00. --- Z80. F	



WEBSITE

Farbe Leuchte / Colour luminaire --- =

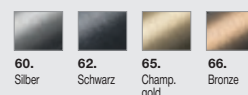

Farbübersicht siehe Seite 67 / Colour chart see page 67

Abhängung = Zuleitung (2 m, matt schwarz).
Suspension = supply cable (2 m, matt black).





FINO PENDANT L 80 cm, mit Deckenbaldachin / with canopy

L x Ø Baldachin Profil [cm] L x Ø canopy profile	LED Watt	Lumen	Gewicht [kg] weight	Lichtfarbe light colour	Dimmung dimming	Art. Nr. Art. No.	Farbe colour
80 x 7,8 2,2	5	365	0,4	2700 K	TRIAC	1534. 27. 11. 00. ---	Z80. F



WEBSITE

Farbe Leuchte / Colour luminaire --- =



Farbübersicht siehe Seite 67 / Colour chart see page 67

3000 K TRIAC **1534. 30.** 11. 00. --- Z80. F

Abhängung = Zuleitung (2 m, matt schwarz).
Suspension = supply cable (2 m, matt black).



FINO PENDANT L 60 cm, mit Stromschienenadapter für PALADIO TRACK / with track adapter for PALADIO TRACK

L x Profil [cm] L x profile	LED Watt	Lumen	Gewicht [kg] weight	Lichtfarbe light colour	Dimmung dimming	Art. Nr. Art. No.	Farbe colour
60 x 2,2	5	365	0,4	2700 K	CASAMBI	1533. 27. 81. 00. ---	Z80. Z



WEBSITE

Farbe Leuchte / Colour luminaire --- =

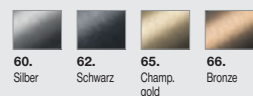

Farbübersicht siehe Seite 67 / Colour chart see page 67

3000 K CASAMBI **1533. 30.** 81. 00. --- Z80. Z

2700 K DALI **1533. 27.** 61. 00. --- Z80. Z

3000 K DALI **1533. 30.** 61. 00. --- Z80. Z

Abhängung = Zuleitung (2 m, matt schwarz).
Suspension = supply cable (2 m, matt black).



FINO PENDANT L 80 cm, mit Stromschienenadapter für PALADIO TRACK / with track adapter for PALADIO TRACK

L x Profil [cm] L x profile	LED Watt	Lumen	Gewicht [kg] weight	Lichtfarbe light colour	Dimmung dimming	Art. Nr. Art. No.	Farbe colour
80 x 2,2	5	365	0,4	2700 K	CASAMBI	1534. 27. 81. 00. ---	Z80. Z



WEBSITE

Farbe Leuchte / Colour luminaire --- =



Farbübersicht siehe Seite 67 / Colour chart see page 67

3000 K CASAMBI **1534. 30.** 81. 00. --- Z80. Z

2700 K DALI **1534. 27.** 61. 00. --- Z80. Z

3000 K DALI **1534. 30.** 61. 00. --- Z80. Z

Abhängung = Zuleitung (2 m, matt schwarz).
Suspension = supply cable (2 m, matt black).



AVVENI PENDANT 1 Leuchtenkopf (Flood) und Deckenbaldachin / Light head (Flood) and canopy

H x Ø Kopf [cm] H x Ø light head	LED Watt	Lumen	Gewicht [kg] weight	Lichtfarbe light colour	Dimmung dimming	Art. Nr. Struktur Art. No. structure	Art. Nr. Leuchtenkopf Art. No. light head
10,1 x 19,6	13	1.027	0,8	2700 K	DALI	1211. 00. 06. 82. 0F	02. 62. 62. 27. 99. 00. 00



WEBSITE

Farbe Ring + Farbe Abdeckung / colour ring + colour cover

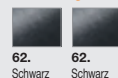

62. Schwarz 62. Schwarz

Farbübersicht siehe Seite 67 / Colour chart see page 67

3000 K	DALI	1211. 00. 06. 82. 0F	02. 62. 62. 30. 99. 00. 00
2700 K	CASAMBI	1211. 00. 08. 82. 0F	02. 62. 62. 27. 99. 00. 00
3000 K	CASAMBI	1211. 00. 08. 82. 0F	02. 62. 62. 30. 99. 00. 00

Zuleitung schwarz Z 82, 2m / Supply cable black Z 82, 2m

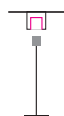

AVVENI PENDANT 1 Leuchtenkopf (Flood) und Stromschienenadapter für PALADIO TRACK / Light head (Flood) and track adapter for PALADIO TRACK

H x Ø Kopf [cm] H x Ø light head	LED Watt	Lumen	Gewicht [kg] weight	Lichtfarbe light colour	Dimmung dimming	Art. Nr. Struktur Art. No. structure	Art. Nr. Leuchtenkopf Art. No. light head
10,1 x 19,6	13	1.027	0,8	2700 K	DALI	1211. 00. 06. 82. 0Z	02. 62. 62. 27. 99. 00. 00



WEBSITE

Farbe Ring + Farbe Abdeckung / colour ring + colour cover

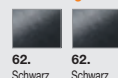

62. Schwarz 62. Schwarz

Farbübersicht siehe Seite 67 / Colour chart see page 67

3000 K	DALI	1211. 00. 06. 82. 0Z	02. 62. 62. 30. 99. 00. 00
2700 K	CASAMBI	1211. 00. 08. 82. 0Z	02. 62. 62. 27. 99. 00. 00
3000 K	CASAMBI	1211. 00. 08. 82. 0Z	02. 62. 62. 30. 99. 00. 00

Zuleitung schwarz Z 82, 2m / Supply cable black Z 82, 2m



AVVENI PENDANT 4 Leuchtenkopf (Flood) und Deckenbaldachin / Light head (Flood) and canopy

H x Ø Kopf [cm] H x Ø light head	LED Watt	Lumen	Gewicht [kg] weight	Lichtfarbe light colour	Dimmung dimming	Art. Nr. Struktur Art. No. structure	Art. Nr. Leuchtenkopf Art. No. light head
158,1 x 95,7	68	5.376	4,0	2700 K	DALI	1210. -- 06. 00. 0F	01. -- -- -- 27. 99. 00. 00



WEBSITE

Farbe Baldachin | Struktur / Colour canopy | structure -- -- =

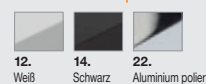

12. Weiß 14. Schwarz 22. Aluminium poliert

Farbe Ring + Farbe Abdeckung / colour ring + colour cover -- -- =

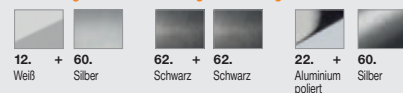

12. + 60. Weiß Silber 62. + 62. Schwarz Schwarz 22. + 60. Aluminium poliert Silber

Farbübersicht siehe Seite 67 / Colour chart see page 67

3000 K	DALI	1210. -- 06. 00. 0F	01. -- -- -- 30. 99. 00. 00
2700 K	CASAMBI	1210. -- 08. 00. 0F	01. -- -- -- 30. 99. 00. 00
3000 K	CASAMBI	1210. -- 08. 00. 0F	01. -- -- -- 30. 99. 00. 00

Mit dezenter Stahlseilabhangung und integrierter Stromfuhrung
With discreet steel cable suspension and integrated power supply.

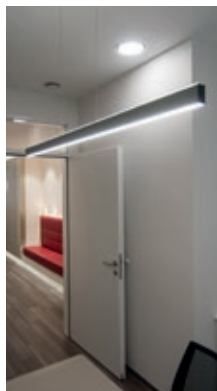

DOPPIO LINEA L 127 cm, direkt/indirekt, mit Längsbaldachin / direct/indirect, with canopy

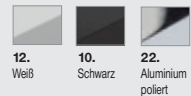
L x B x H Profil [cm] L x W x H profile	LED Watt	Lumen	Gewicht [kg] weight	Lichtfarbe light colour	Dimmung dimming	Art. Nr. Art. No.	Farbe colour
127 x 2,3 x 4,6	23 / 9	1.219 / 480	2,0	2700 K	CASAMBI	794. 27. 82. 27.	-- 000. F
 WEBSITE	Farbe Leuchte / Colour luminaire -- = 			3000 K	CASAMBI	794. 30. 82. 30.	-- 000. F
				2700 K	DALI	794. 27. 62. 27.	-- 000. F
				3000 K	DALI	794. 30. 62. 30.	-- 000. F
				2700 K	TRIAC	794. 27. 11. 27.	-- 000. F
				3000 K	TRIAC	794. 30. 11. 30.	-- 000. F

Direkt und indirekt leuchtend, mit dezenter Stahlseilabhängung und integrierter Stromführung.
Direct and indirect lighting, discreet suspension with current-carrying steel cables.

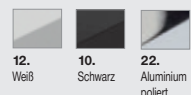

DOPPIO LINEA L 152 cm, direkt/indirekt, mit Längsbaldachin / direct/indirect, with canopy

L x B x H Profil [cm] L x W x H profile	LED Watt	Lumen	Gewicht [kg] weight	Lichtfarbe light colour	Dimmung dimming	Art. Nr. Art. No.	Farbe colour
152 x 2,3 x 4,6	28 / 11	1.489 / 587	2,5	2700 K	CASAMBI	795. 27. 82. 27.	-- 000. F
 WEBSITE	Farbe Leuchte / Colour luminaire -- = 			3000 K	CASAMBI	795. 30. 82. 30.	-- 000. F
				2700 K	DALI	795. 27. 62. 27.	-- 000. F
				3000 K	DALI	795. 30. 62. 30.	-- 000. F
				2700 K	TRIAC	795. 27. 11. 27.	-- 000. F
				3000 K	TRIAC	795. 30. 11. 30.	-- 000. F

Direkt und indirekt leuchtend, mit dezenter Stahlseilabhängung und integrierter Stromführung.
Direct and indirect lighting, discreet suspension with current-carrying steel cables.

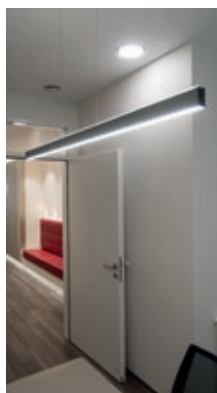

DOPPIO LINEA L 212 cm, direkt/indirekt, mit Längsbaldachin / direct/indirect, with canopy

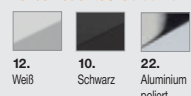
L x B x H Profil [cm] L x W x H profile	LED Watt	Lumen	Gewicht [kg] weight	Lichtfarbe light colour	Dimmung dimming	Art. Nr. Art. No.	Farbe colour
212 x 2,3 x 4,6	39 / 15	2.051 / 805	3,0	2700 K	CASAMBI	796. 27. 82. 27.	-- 000. F
 WEBSITE	Farbe Leuchte / Colour luminaire -- = 			3000 K	CASAMBI	796. 30. 82. 30.	-- 000. F
				2700 K	DALI	796. 27. 62. 27.	-- 000. F
				3000 K	DALI	796. 30. 62. 30.	-- 000. F
				2700 K	TRIAC	796. 27. 11. 27.	-- 000. F
				3000 K	TRIAC	796. 30. 11. 30.	-- 000. F

Direkt und indirekt leuchtend, mit dezenter Stahlseilabhängung und integrierter Stromführung.
Direct and indirect lighting, discreet suspension with current-carrying steel cables.



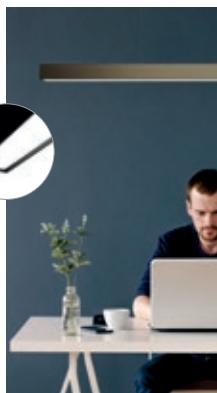

PALADIO 35 OPAL L 141 cm, direkt/indirekt, lineare Pendelleuchte mit opalem Diffusor / direct/indirect, linear pendant luminaire with opal diffuser

L x B x H L x W x H	Profil [cm] profil	LED Watt	Lumen	Gewicht [kg] weight	Lichtfarbe light colour	Dimmung dimming	Art. Nr. Art. No.	Farbe colour
141 x 3,5 x 7		25 / 10	2.600 / 960	3,0	2700 K	DALI	2081. 0A.	-- 27. 99. 27. 99. 06. A15.
					3000 K	DALI	2081. 0A.	-- 30. 99. 30. 99. 06. A15.
					2700 K	CASAMBI	2081. 0A.	-- 27. 99. 27. 99. 08. A15.
					3000 K	CASAMBI	2081. 0A.	-- 30. 99. 30. 99. 08. A15.



WEBSITE

Farbe Leuchte / Colour luminaire -- =



Farbübersicht siehe Seite 67 / Colour chart see page 67

Direkt und indirekt leuchtend / Direct and indirect illumination

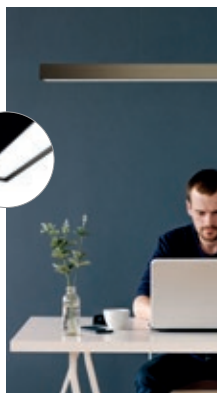

PALADIO 35 OPAL L 169 cm, direkt/indirekt, lineare Pendelleuchte mit opalem Diffusor / direct/indirect, linear pendant luminaire with opal diffuser

L x B x H L x W x H	Profil [cm] profile	LED Watt	Lumen	Gewicht [kg] weight	Lichtfarbe light colour	Dimmung dimming	Art. Nr. Art. No.	Farbe colour
169 x 3,5 x 7		30 / 10	3.080 / 960	3,5	2700 K	DALI	2086. 0A.	-- 27. 99. 27. 99. 06. A15.
					3000 K	DALI	2086. 0A.	-- 30. 99. 30. 99. 06. A15.
					2700 K	CASAMBI	2086. 0A.	-- 27. 99. 27. 99. 08. A15.
					3000 K	CASAMBI	2086. 0A.	-- 30. 99. 30. 99. 08. A15.



WEBSITE

Farbe Leuchte / Colour luminaire -- =



Farbübersicht siehe Seite 67 / Colour chart see page 67

Direkt und indirekt leuchtend / Direct and indirect illumination



PALADIO 35 LENS L 141 cm, direkt/indirekt, lineare Pendelleuchte mit Linsen Reflektor / direct/indirect, linear pendant luminaire with opal diffuser

L x B x H L x W x H	Profil [cm] profile	LED Watt	Lumen	Gewicht [kg] weight	Lichtfarbe light colour	Dimmung dimming	Art. Nr. Art. No.	Farbe colour
141 x 3,5 x 7		16 / 16	1.988 / 1.65	3,0	2700 K	DALI	2081. 0A.	-- 27. 32. 27. 99. 06. A15.
					3000 K	DALI	2081. 0A.	-- 30. 32. 30. 99. 06. A15.
					2700 K	CASAMBI	2081. 0A.	-- 27. 32. 27. 99. 08. A15.
					3000 K	CASAMBI	2081. 0A.	-- 30. 32. 30. 99. 08. A15.



WEBSITE

Farbe Leuchte / Colour luminaire -- =



Farbübersicht siehe Seite 67 / Colour chart see page 67

Direkt und indirekt leuchtend / Direct and indirect illumination





PALADIO 35 LENS L 169 cm, direkt/indirekt, lineare Pendelleuchte mit Linsen Reflektor / direct/indirect, linear pendant luminaire with lens reflector

L x B x H L x W x H	Profil [cm] profile	LED Watt	Lumen	Gewicht [kg] weight	Lichtfarbe light colour	Dimmung dimming	Art. Nr. Art. No.	Farbe colour
169 x 3,5 x 7		16 / 16	1.986 / 1.650	3,5	2700 K	DALI	2086. 0A.	27. 32. 27. 99. 06. A15.
					3000 K	DALI	2086. 0A.	30. 32. 30. 99. 06. A15.
					2700 K	CASAMBI	2086. 0A.	27. 32. 27. 99. 08. A15.
					3000 K	CASAMBI	2086. 0A.	30. 32. 30. 99. 08. A15.



WEBSITE

Farbe Leuchte / Colour luminaire -- =



Farbübersicht siehe Seite 67 / Colour chart see page 67

Direkt und indirekt leuchtend / Direct and indirect illumination



PALADIO 35 LENS L 225 cm, direkt/indirekt, lineare Pendelleuchte mit Linsen Reflektor / direct/indirect, linear pendant luminaire with lens reflector

L x B x H L x W x H	Profil [cm] profile	LED Watt	Lumen	Gewicht [kg] weight	Lichtfarbe light colour	Dimmung dimming	Art. Nr. Art. No.	Farbe colour
225 x 3,5 x 7		32 / 32	3.976 / 3.300	4,7	2700 K	DALI	2082. 0A.	27. 32. 27. 99. 06. A15.
					3000 K	DALI	2082. 0A.	30. 32. 30. 99. 06. A15.
					2700 K	CASAMBI	2082. 0A.	27. 32. 27. 99. 08. A15.
					3000 K	CASAMBI	2082. 0A.	30. 32. 30. 99. 08. A15.



WEBSITE

Farbe Leuchte / Colour luminaire -- =



Farbübersicht siehe Seite 67 / Colour chart see page 67

Direkt und indirekt leuchtend / Direct and indirect illumination



PALADIO 35 LENS L 281 cm, direkt/indirekt, lineare Pendelleuchte mit Linsen Reflektor / direct/indirect, linear pendant luminaire with lens reflector

L x B x H L x W x H	Profil [cm] profile	LED Watt	Lumen	Gewicht [kg] weight	Lichtfarbe light colour	Dimmung dimming	Art. Nr. Art. No.	Farbe colour
281 x 3,5 x 7		32 / 32	3.976 / 3.300	5,9	2700 K	DALI	2083. 0A.	27. 32. 27. 99. 06. A15.
					3000 K	DALI	2083. 0A.	30. 32. 30. 99. 06. A15.
					2700 K	CASAMBI	2083. 0A.	27. 32. 27. 99. 08. A15.
					3000 K	CASAMBI	2083. 0A.	30. 32. 30. 99. 08. A15.



WEBSITE

Farbe Leuchte / Colour luminaire -- =

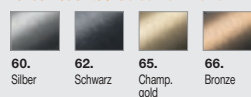

Farbübersicht siehe Seite 67 / Colour chart see page 67

Direkt und indirekt leuchtend / Direct and indirect illumination





PALADIO 35 LENS L 141 cm, lineare Anbauleuchte mit Linsen Reflektor / linear surface-mounted luminaire with lens reflector

L x B x H Profil [cm] L x W x H profile	LED Watt	Lumen	Gewicht [kg] weight	Lichtfarbe light colour	Dimmung dimming	Art. Nr. Art. No.	Farbe colour
141 x 3,5 x 7	16	1.988	3,0	2700 K	DALI	2081. 0P.	27. 32. 00. 00. 06. 000.



WEBSITE

Farbe Leuchte / Colour luminaire -- =

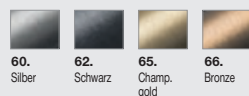

Farbübersicht siehe Seite 67 / Colour chart see page 67

3000 K	DALI	2081. 0P.	30. 32. 00. 00. 06. 000.
2700 K	CASAMBI	2081. 0P.	27. 32. 00. 00. 08. 000.
3000 K	CASAMBI	2081. 0P.	30. 32. 00. 00. 08. 000.



PALADIO 35 LENS L 169 cm, lineare Anbauleuchte mit Linsen Reflektor / linear surface-mounted luminaire with lens reflector

L x B x H Profil [cm] L x W x H profile	LED Watt	Lumen	Gewicht [kg] weight	Lichtfarbe light colour	Dimmung dimming	Art. Nr. Art. No.	Farbe colour
169 x 3,5 x 7	30	3.080	3,5	2700 K	DALI	2086. 0P.	27. 32. 00. 00. 06. 000.



WEBSITE

Farbe Leuchte / Colour luminaire -- =

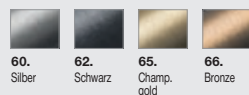

Farbübersicht siehe Seite 67 / Colour chart see page 67

3000 K	DALI	2086. 0P.	30. 32. 00. 00. 06. 000.
2700 K	CASAMBI	2086. 0P.	27. 32. 00. 00. 08. 000.
3000 K	CASAMBI	2086. 0P.	30. 32. 30. 00. 08. 000.



PALADIO 35 LENS L 225 cm, lineare Anbauleuchte mit Linsen Reflektor / linear surface-mounted luminaire with lens reflector

L x B x H Profil [cm] L x W x H profile	LED Watt	Lumen	Gewicht [kg] weight	Lichtfarbe light colour	Dimmung dimming	Art. Nr. Art. No.	Farbe colour
225 x 3,5 x 7	32	3.976	4,7	2700 K	DALI	2082. 0P.	27. 32. 00. 00. 06. 000.



WEBSITE

Farbe Leuchte / Colour luminaire -- =

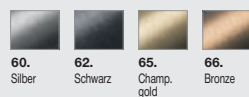

Farbübersicht siehe Seite 67 / Colour chart see page 67

3000 K	DALI	2082. 0P.	30. 32. 00. 00. 06. 000.
2700 K	CASAMBI	2082. 0P.	27. 32. 00. 00. 08. 000.
3000 K	CASAMBI	2082. 0P.	30. 32. 00. 00. 08. 000.





PALADIO 35 LENS L 281 cm, lineare Anbauleuchte mit Linsen Reflektor / linear surface-mounted luminaire with lens reflector

L x B x H Profil [cm] L x W x H profile	LED Watt	Lumen	Gewicht [kg] weight	Lichtfarbe light colour	Dimmung dimming	Art. Nr. Art. No.	Farbe colour
281 x 3,5 x 7	32	3.976	5,9	2700 K	DALI	2083. 0P.	27. 32. 00. 00. 06. 000.
				3000 K	DALI	2083. 0P.	30. 32. 00. 00. 06. 000.
				2700 K	CASAMBI	2083. 0P.	27. 32. 00. 00. 08. 000.
				3000 K	CASAMBI	2083. 0P.	30. 32. 00. 00. 08. 000.



WEBSITE

Farbe Leuchte / Colour luminaire -- =

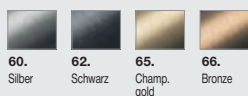

Farbübersicht siehe Seite 67 / Colour chart see page 67



PALADIO 35 TRACK mit EVOLUTION SPOT

PALADIO 35 TRACK lineares Anbauelement mit integrierter 48V-Stromschiene mit DALI / linear surface-mounted element with integrated 48V track with DALI

L x B x H Profil [cm] L x W x H profile	Gewicht [kg] weight	Dimmung dimming	Art. Nr. Art. No.	Farbe colour
169 x 3,5 x 7	4,5	DALI	2066. 0P.	00. 01 00. 00. 06. 000.
225 x 3,5 x 7	5,7	DALI	2062. 0P.	00. 01 00. 00. 06. 000.
281 x 3,5 x 7	5,9	DALI	2063. 0P.	00. 01 00. 00. 06. 000.



WEBSITE

Farbe Leuchte / Colour luminaire -- =



Farbübersicht siehe Seite 67 / Colour chart see page 67

PALADIO 35 TRACK 48V-Stromschiene mit DALI / 48V track with DALI

PALADIO 35 TRACK mit DALI-Dimmung ist kompatibel mit **CASAMBI-** oder **DALI-** dimmbaren Leuchten (PALADIO TRACK 35 | LIGHT ELEMENTS - S.65).

PALADIO 35 TRACK with DALI dimming is compatible with **CASAMBI** or **DALI** dimmable luminaires (PALADIO TRACK 35 | LIGHT ELEMENTS - p.65).

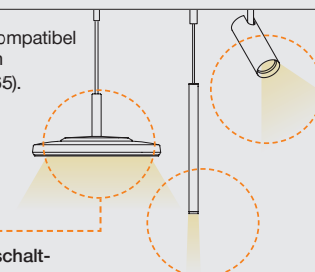

LIGHT ELEMENTS
Leuchten mit
luminaires with
DALI

Alle Leuchten einzeln schalt- und dimmbar. Auch geeignet für einfaches ein/aus ohne DALI Steuerung im Haus.

All luminaires individually switchable and dimmable. Also suitable for simple on/off without DALI control in the house.

LIGHT ELEMENTS
Leuchten mit
luminaires with
CASAMBI

Alle Leuchten via Bluetooth einzeln schalt- und dimmbar.

All luminaires can be individually switched and dimmed via Bluetooth.



PALADIO 35 TRACK mit EVOLUTION SPOT

PALADIO 35 TRACK lineares Anbauelement mit integrierter **48V-Stromschiene mit CASAMBI** / linear surface-mounted element with integrated **48V track with CASAMBI**

L x B x H Profil [cm] L x W x H profile	Gewicht [kg] weight	Dimmung dimming	Art. Nr. Art. No.	Farbe colour
169 x 3,5 x 7	4,5	CASAMBI	2066. 0P.	00. 01 00. 00. 08. 000.
225 x 3,5 x 7	5,7	CASAMBI	2062. 0P.	00. 01 00. 00. 08. 000.
281 x 3,5 x 7	5,9	CASAMBI	2063. 0P.	00. 01 00. 00. 08. 000.



WEBSITE

Farbe Leuchte / Colour luminaire

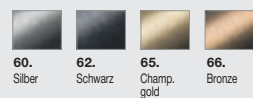

Farbübersicht siehe Seite 67 / Colour chart see page 67

PALADIO 35 TRACK 48V-Stromschiene mit CASAMBI / 48V track with CASAMBI

LIGHT ELEMENTS
Leuchten mit
luminaires with
DALI

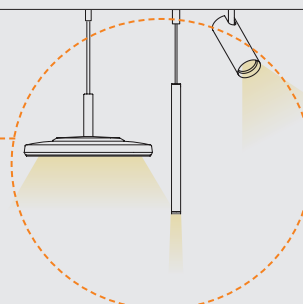

PALADIO 35 TRACK mit CASAMBI-
Dimmung ermöglicht es Leuchten mit **DALI-**
Dimmung via Bluetooth **gemeinsam zu**
schalten und zu dimmen.

PALADIO 35 TRACK equipped with
CASAMBI dimming enables luminaires with **DALI** dimming
to be **switched and dimmed together** via Bluetooth.

PALADIO 35 TRACK | LIGHT ELEMENTS

optionale Leuchten für Stromschiene / optional luminaires for track



AVVENI PENDANT 1
S. 59



FINO PENDANT
S. 58



EVOLUTION SPOT 24° / 38°
S. 66

PALADIO 35 TRACK

ist mit Einzeleuchten einer Gesamtwattage bis zu 100 W bestückbar.
can be equipped with individual luminaires with a total wattage of up to 100 W.

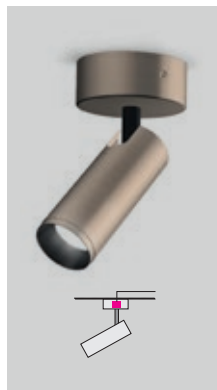

EVOLUTION SPOT 24° / 38° mit Deckenbaldachin / with canopy

H (max.) x Ø Baldachin Profil [cm] H (max.) x Ø canopy profile	LED Watt	Lumen	Gewicht [kg] weight	Abstrahlwinkel beam angle	Lichtfarbe light colour	Dimmung dimming	Art. Nr. Art. No.	Farbe colour
---	----------	-------	------------------------	------------------------------	----------------------------	--------------------	----------------------	-----------------

18 x 8 | 4,2

6

858

0,4



WEBSITE

Farbe Leuchte / Colour luminaire _ _ _ =



Farbübersicht siehe Seite 67 / Colour chart see page 67



24°

2700 K
3000 KTRIAC
TRIAC1778. 27. 11. 00. ---
1778. 30. 11. 00. ---000. P
000. P

38°

2700 K
3000 KTRIAC
TRIAC1779. 27. 11. 00. ---
1779. 30. 11. 00. ---000. P
000. P

EVOLUTION SPOT 24° / 38° mit Stromschienenadapter für PALADIO TRACK / with track adapter for PALADIO TRACK

L x Ø [cm] L x Ø	LED Watt	Lumen	Gewicht [kg] weight	Abstrahlwinkel beam angle	Lichtfarbe light colour	Dimmung dimming	Art. Nr. Art. No.	Farbe colour
---------------------	----------	-------	------------------------	------------------------------	----------------------------	--------------------	----------------------	-----------------

11 | 4,2

6

858

0,4



WEBSITE

Farbe Leuchte / Colour luminaire _ _ _ =

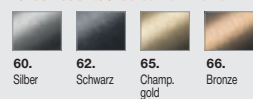

Farbübersicht siehe Seite 67 / Colour chart see page 67



24°

2700 K
3000 KCASAMBI
CASAMBI1778. 27. 08. 00. ---
1778. 30. 08. 00. ---000. Z
000. Z24°
24°DALI
DALI1778. 27. 61. 00. ---
1778. 30. 61. 00. ---000. Z
000. Z

38°

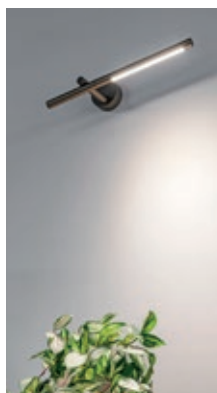
2700 K
3000 KCASAMBI
CASAMBI1779. 27. 08. 00. ---
1779. 30. 08. 00. ---000. Z
000. Z38°
38°DALI
DALI1779. 27. 61. 00. ---
1779. 30. 61. 00. ---000. Z
000. Z

PALITO WALL L 42 cm

L (max.) x (Baldachin Profil) [cm] L (max.) x (Canopy profile)	LED Watt	Lumen	Gewicht [kg] weight	Lichtfarbe light colour	Dimmung dimming	Art. Nr. Art. No.	Farbe colour
---	----------	-------	------------------------	----------------------------	--------------------	----------------------	-----------------

42 x 7,8 | 2,2

6,5

650

1,0



WEBSITE

Farbe Leuchte / Colour luminaire _ _ _ =



Farbübersicht siehe Seite 67 / Colour chart see page 67

2700 K

TRIAC

1544. 27. 11. 00. ---

000. P

3000 K

TRIAC

1544. 30. 11. 00. ---

000. P

Für Decken- und Wandmontage geeignet.
Suitable for ceiling and wall mounting.



AVVENI SINGLE Leuchtenkopf (Flood) / light head (Flood)

H (max.) x Ø Baldachin Kopf [cm] H (max.) x Ø canopy light head	LED Watt	Lumen	Gewicht [kg] weight	Lichtfarbe light colour	Dimmung dimming	Art. Nr. Struktur Art. No. structure	Art. Nr. Leuchtenkopf Art. No. light head
28,5 x 13,4 19,6	17	1.344	1,6	2700 K	DALI	1112. --- 06. 00. 0P	01. --- -- 27. 99. 00. 00



WEBSITE

Farbe Baldachin | Struktur / Colour canopy | structure _ _ =

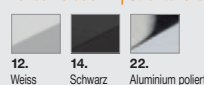

Farbe Ring + Farbe Abdeckung / colour ring + colour cover _ _ _ _ =

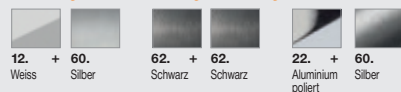

Farbübersicht siehe Seite 67 / Colour chart see page 67

3000 K	DALI	1112. --- 06. 00. 0P	01. --- -- 30. 99. 00. 00
2700 K	CASAMBI	1112. --- 08. 00. 0P	01. --- -- 27. 99. 00. 00
3000 K	CASAMBI	1112. --- 08. 00. 0P	01. --- -- 30. 99. 00. 00

Für Decken- und Wandmontage geeignet.
Suitable for ceiling and wall mounting.



AVVENI SINGLE Leuchtenkopf (Spot) 24° / light head (Spot) 24°

H (max.) x Ø Baldachin Kopf [cm] H (max.) x Ø canopy light head	LED Watt	Lumen	Gewicht [kg] weight	Lichtfarbe light colour	Dimmung dimming	Art. Nr. Struktur Art. No. structure	Art. Nr. Leuchtenkopf Art. No. light head
28,5 x 13,4 19,6	19	1.268	1,6	2700 K	DALI	1112. --- 06. 00. 0P	01. --- -- 27. 24. 00. 00



WEBSITE

Farbe Baldachin | Struktur / Colour canopy | structure _ _ =

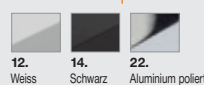

Farbe Ring + Farbe Abdeckung / colour ring + colour cover _ _ _ _ =

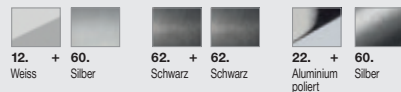

Farbübersicht siehe Seite 67 / Colour chart see page 67

3000 K	DALI	1112. --- 06. 00. 0P	01. --- -- 30. 24. 00. 00
2700 K	CASAMBI	1112. --- 08. 00. 0P	01. --- -- 27. 24. 00. 00
3000 K	CASAMBI	1112. --- 08. 00. 0P	01. --- -- 30. 24. 00. 00

Für Decken- und Wandmontage geeignet.
Suitable for ceiling and wall mounting.



CASAMBI Wandschalter / wall switch

Der drahtlose CASAMBI Wandschalter vereint maximale Flexibilität und modernes Design. Mit ihm steuern Sie ohne Verdrahtung von jedem beliebigen Ort im Raum aus die an das CASAMBI Netzwerk angeschlossenen Leuchten. Mittels CASAMBI App lassen sich die vier Tasten individuell konfigurieren. Leuchten können so entsprechend zugeordnet und somit geschaltet oder auch gedimmt werden.

The wireless CASAMBI wall switch combines maximum flexibility and modern design. It allows you to control the luminaires connected to the CASAMBI network from anywhere in the room without wiring. The four buttons can be individually configured using the CASAMBI app. Luminaires can be assigned accordingly and thus switched or dimmed.

CASAMBI Wandschalter / wall switch

Art. Nr.	weiß / white:	207. 00. 00. 00. 12.
	schwarz / black:	207. 00. 00. 00. 10.

Bei Verwendung von **DALI** oder **CASAMBI** sind verschiedene Lichtszenen individuell programmier- und realisierbar, um verschiedene Atmosphären im Raum zu schaffen.
Using **DALI** or **CASAMBI**, different lighting scenes can be individually programmed and realised to create different atmospheres in the room.

WEITERE LEUCHTEN AUS UNSEREM PORTFOLIO



ANELLO | LIGHT + ACOUSTIC PANEL



FAVO CELL



SLIM DIRECT



AVVENI CEILING 4



SOFT DELTA LIGHT + ACOUSTIC

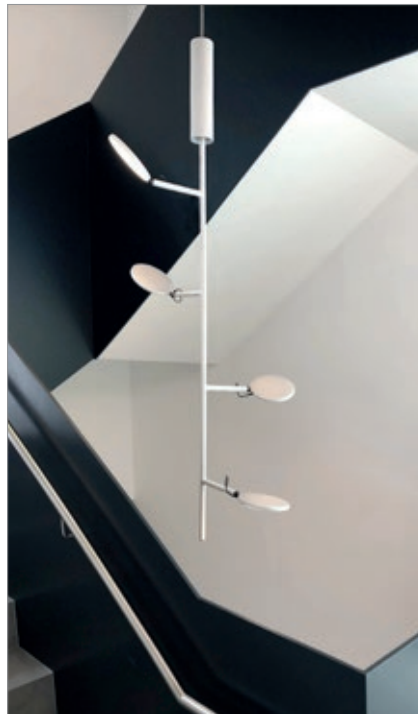

AVVENI VERTICAL



GIOCO

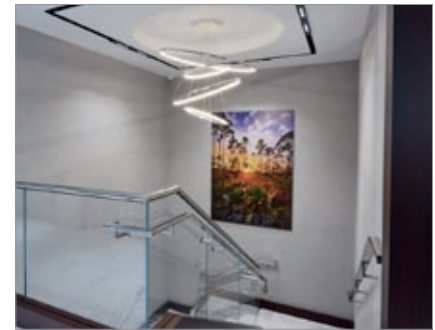

GIRATA Lichtobjekt



SLIM DIRECT

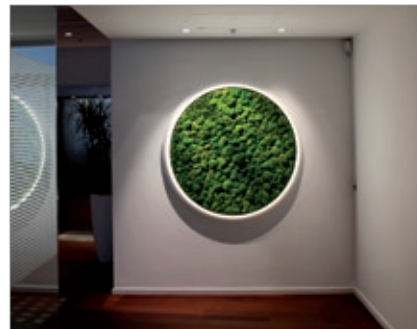

LUCE VERDE SLIM



PALADIO TRACK 35 | SLIM

OTHER LUMINAIRES FROM OUR PORTFOLIO



SLIM DIRECT (ANBAU)

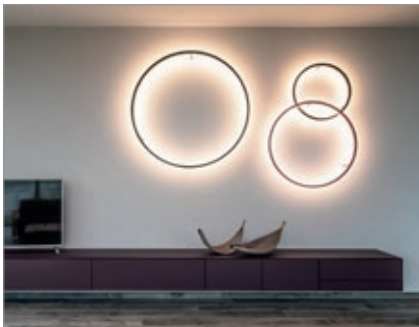

SLIM WALL



SLIM DIRECT



GIOCO | AVVENI SINGLE



INSIEME Sonderleuchte



AVVENI PENDANT 8 | AVVENI TABLE



EVOLUTION



SLIM IN



GIRATA VERTICAL



SLIM DELTA DIRECT

Bildverzeichnis / Image directory

Seite 2,3 | Photo: ©Liebel Architekten, Aalen - Haus Zochental
Seite 7 | Photo: bildhübsche fotografie | Andreas Körner
Seite 9 | Photo: Alex Wunsch
Seite 17 | Photo: bildhübsche fotografie | Andreas Körner
Seite 19 | Photo: bildhübsche fotografie | Andreas Körner – Brunner Group
Seite 22 | Photo: Gergo Gosztom, Designer: Insidesign kft Csilla Salloi, Szilvia Simko
Seite 23 | Photo: LipsiART digital photography, René Krause | Kochschule Andrea Lange, Ludwigsburg | henger+heyn, architekten, Ludwigsburg
Seite 27 | Photo: L/A LIEBEL ARCHITEKTEN, Aalen
Seite 28 links | Photo: © U-Team, Beijing
Seite 28 rechts | Photo: © Luminarium
Seite 29 | Photo: Christoph Tempes | Bürovilla | Multiline, Bad Homburg
Seite 30 | Photo: ©LICHT CUBE, Tolga Gündug
Seite 38 | Photo: Architekt: Guido Kummer & Partner, Solothurn | Distributed by: LUXED
Seite 46 links | Photo: ©Lohmann und Rauscher Academy | Pro Office GmbH
Seite 46 rechts | Photo: ©Luminarium
Seite 47 – 1. Reihe, 1. Bild | AVVENI VERTICAL 4 | Willwersch Architekten, Stuttgart
Seite 47 – 2. Reihe, 1. Bild | EVOLUTION | MSG Life, Köln
Seite 68 – 1. Reihe, 1. Bild | Photo: Nikolay Kazakov | La Biosthétique | Asal + Traub Architekten
Seite 68 – 1. Reihe, 3. Bild | Photo: Gergo Gosztom, Designer: Insidesign kft Csilla Salloi, Szilvia Simko
Seite 68 – 2. Reihe, 1. Bild | Photo: Nathalie Peters | Infinity – Amsterdam | MVSA Architects – Amsterdam | Unique Brands b.v.
Seite 68 – 2. Reihe, 2. Bild | Willwersch Architekten, Stuttgart
Seite 68 – 2. Reihe, 3. Bild | Photo: GIOCO | Wirth, Gelnhausen | IDEE RAUMKONZEPT KS GmbH
Seite 68 – 2. Reihe, 4. Bild | GIRATAS | Rubenstein
Seite 68 – 3. Reihe, 1. Bild | Photo: gauls die fotografen | Lohmann und Rauscher Academy | Pro Office GmbH
Seite 68 – 3. Reihe, 3. Bild | Photo: LUCE VERDE SLIM | Group M | distributed by: Moller & Rothe
Seite 69 – 1. Reihe, 1. Bild | Photo: © Kreative Raum Konzepte
Seite 69 – 1. Reihe, 3. Bild | Photo: © Lohmann und Rauscher Academy | Pro Office GmbH
Seite 69 – 2. Reihe, 2. Bild | INSIEME | Project: Prinzing Elektrotechnik GmbH, Frankfurt
Seite 69 – 2. Reihe, 4. Bild | Photo: EVOLUTION | MSG Life, Köln
Seite 69 – 3. Reihe, 1. Bild | Photo: Gergo Gosztom, Designer: Insidesign kft Csilla Salloi, Szilvia Simko
Seite 69 – 3. Reihe, 2. Bild | Photo: Steve Lerum | Westfield Mall Topanga Canyon | Designer: Westfield | Distributed by: Inter-Lux
Seite 69 – 3. Reihe, 3. Bild | Photo: © U-Team, Beijing

MONTAGEARTEN | MOUNTING VERSIONS

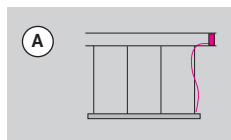

Seilabhängung mit externer Technischeinheit in Zwischendecke.

Suspension with external power supply unit in suspended ceiling.

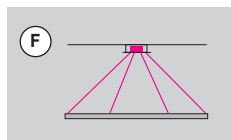

Abhängung mit Deckenbaldachin und strom-führenden Seilen, nicht in Verbindung mit RGB-Farbsteuerung.

Current-carrying steel cables. Not in combination with RGB.

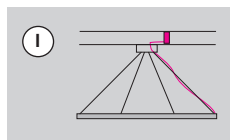

Seilabhängung mit Deckenbaldachin und Zuleitung. Externe Technischeinheit in Zwischendecke.

Suspensions to canopy and power supply cables. External power supply unit in suspended ceiling.

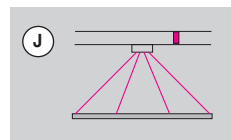

Seilabhängung mit Deckenbaldachin und stromführenden Seilen. Externe Technischeinheit in Zwischendecke.

Suspensions through canopy and current-carrying steel cables. External power supply unit in suspended ceiling.

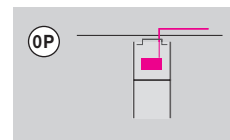

Decken- Direktbefestigung, Technischeinheit in Leuchte.

Direct ceiling-mounting with power supply unit in luminaire.

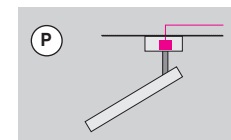

Decken-, Wandbefestigung, Technischeinheit in Baldachin.

Direct ceiling or wall mounting with power supply unit in canopy.

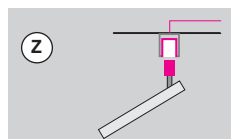

Montage mit Stromschienenadapter für PALADIO TRACK System
Installation with adapter for PALADIO TRACK system (48 V).

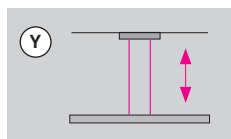

Baldachin mit stufenloser Höhenverstellung und stromführenden Abhängeseilen.
Canopy with stepless height adjustment and current carrying suspension cables.

OBERFLÄCHEN | FINISH

Eloxiert, gebürstet / Anodised, brushed



65 Champagner-Gold
champagne gold

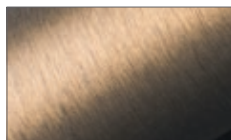

66 Bronze
bronze

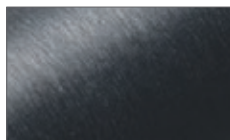

62 Schwarz
black



60 Silber
silver



22 handpoliert
hand polished

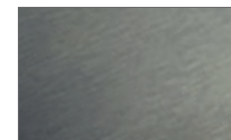

21 Alu natur
alu nature

Pulverbeschichtet / Powder coated



10 Schwarz Feinstruktur
black fine textured



14 Schwarz, glatt matt
black matt

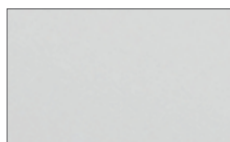

12 Weiß RAL 9003 Feinstruktur matt
white RAL 9003 fine textured matt

weitere Farben siehe Datenblatt oder auf Anfrage
further colours see specification sheet or on request

#sattlerlighting

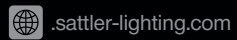
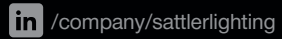

SATTLER GmbH

Wilhelm-Zwick-Str. 6
73035 Göppingen - Germany

Phone: +49 (0) 7161 / 920 193 - 0

E-Mail: info@sattler-lighting.com

Export Department:

Phone: +49 (0) 7161 / 920 193 - 50

Email: export@sattler-lighting.com

www.sattler-lighting.com



SATTLER