

when
light
meets
art

TERZANI
LA LUCE PENSATA

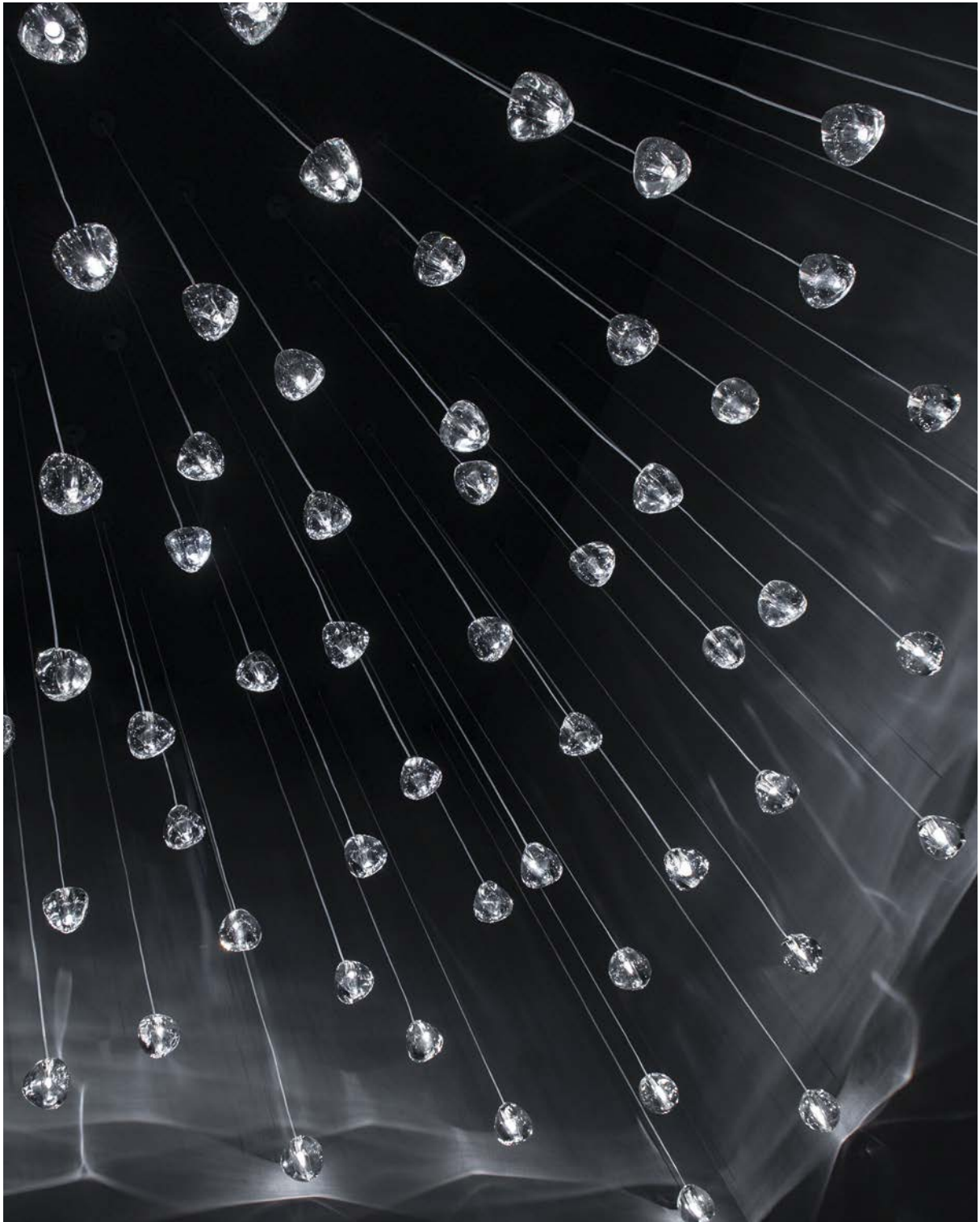

Precious Design

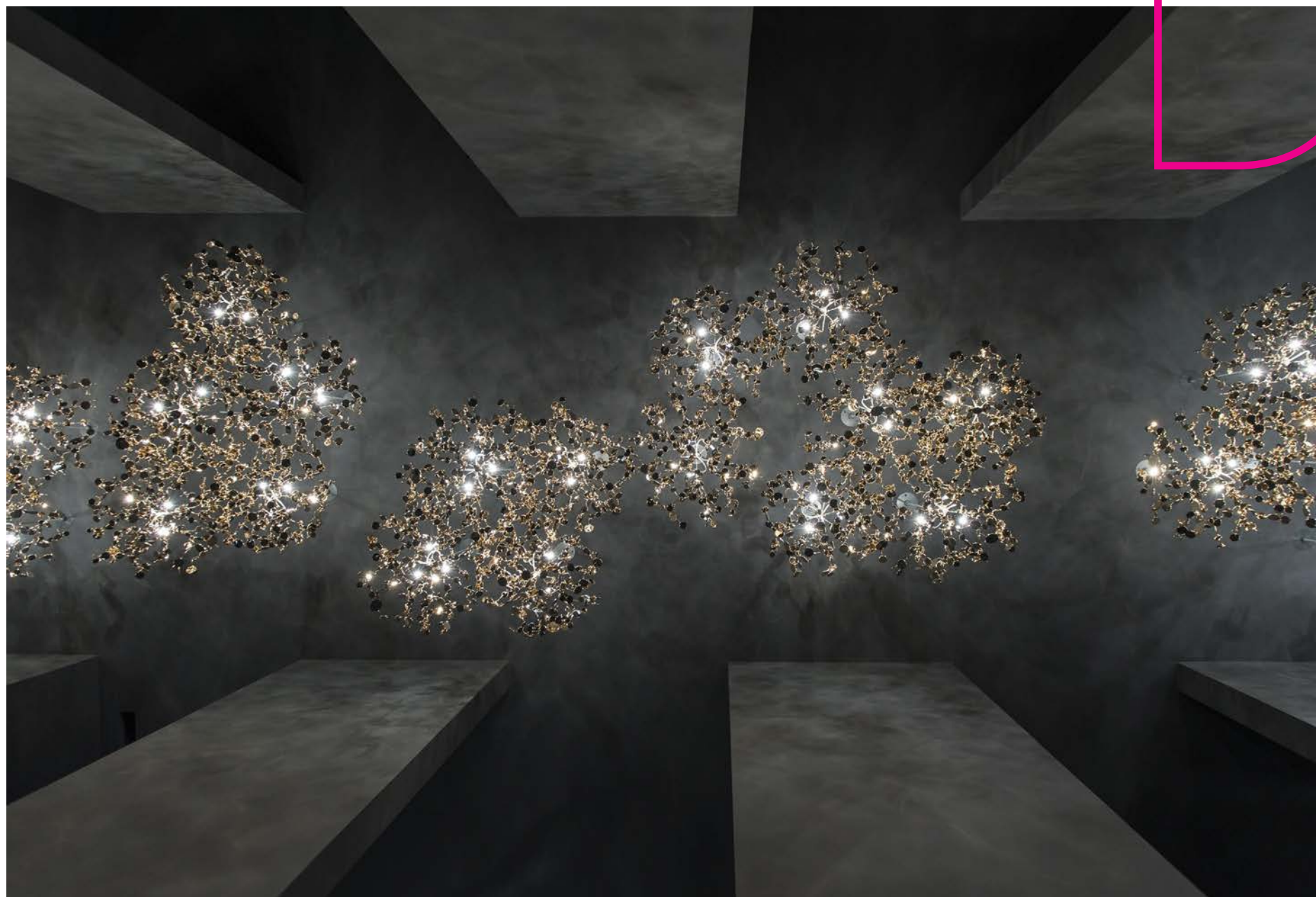

Terzani's Precious Design Concept is luxury evolved. Each piece in this new lighting collection breaks the staid boundaries of traditional luxury, and incorporates stunningly modern design, cutting-edge technology, artisan craftsmanship and precious materials.

When light meets art

The result are sculptures of light whose illumination transforms spaces through dynamic lighting and shadow effects. They create a new visual language of what luxury is, one that reflects both today's aesthetics, architecture and design traditions yet also pushes towards the future.

Index

226	Abacus
338	Angel Falls
344	Anish
128	Argent
024	Argen, mon bijou
070	Atlantis
328	Calle
300	Core
266	Doodle
060	Epoque
374	Etoile
316	Frame
206	Gaia
388	Glamour
352	G.r.a
400	Hugo
310	Iceberg
284	I Lucci Argentati
396	Magdalena
194	Manta
160	Mizu
256	Moiré
362	Orten'zia
246	Oscar
220	Pug
120	Soscik
046	Stanley
094	Stream
382	Tresor
106	Volver
404	Wabi

crea-
tivity

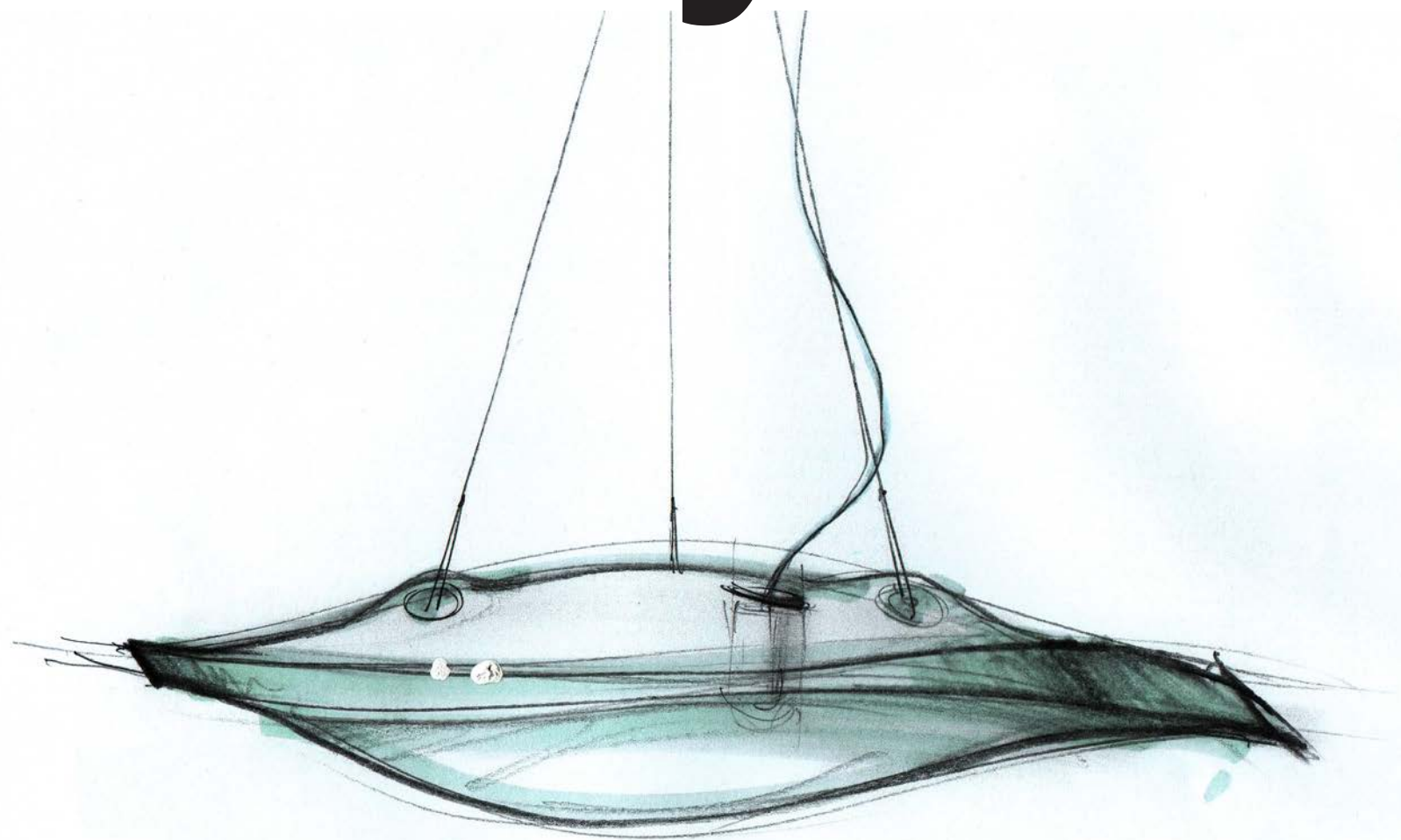
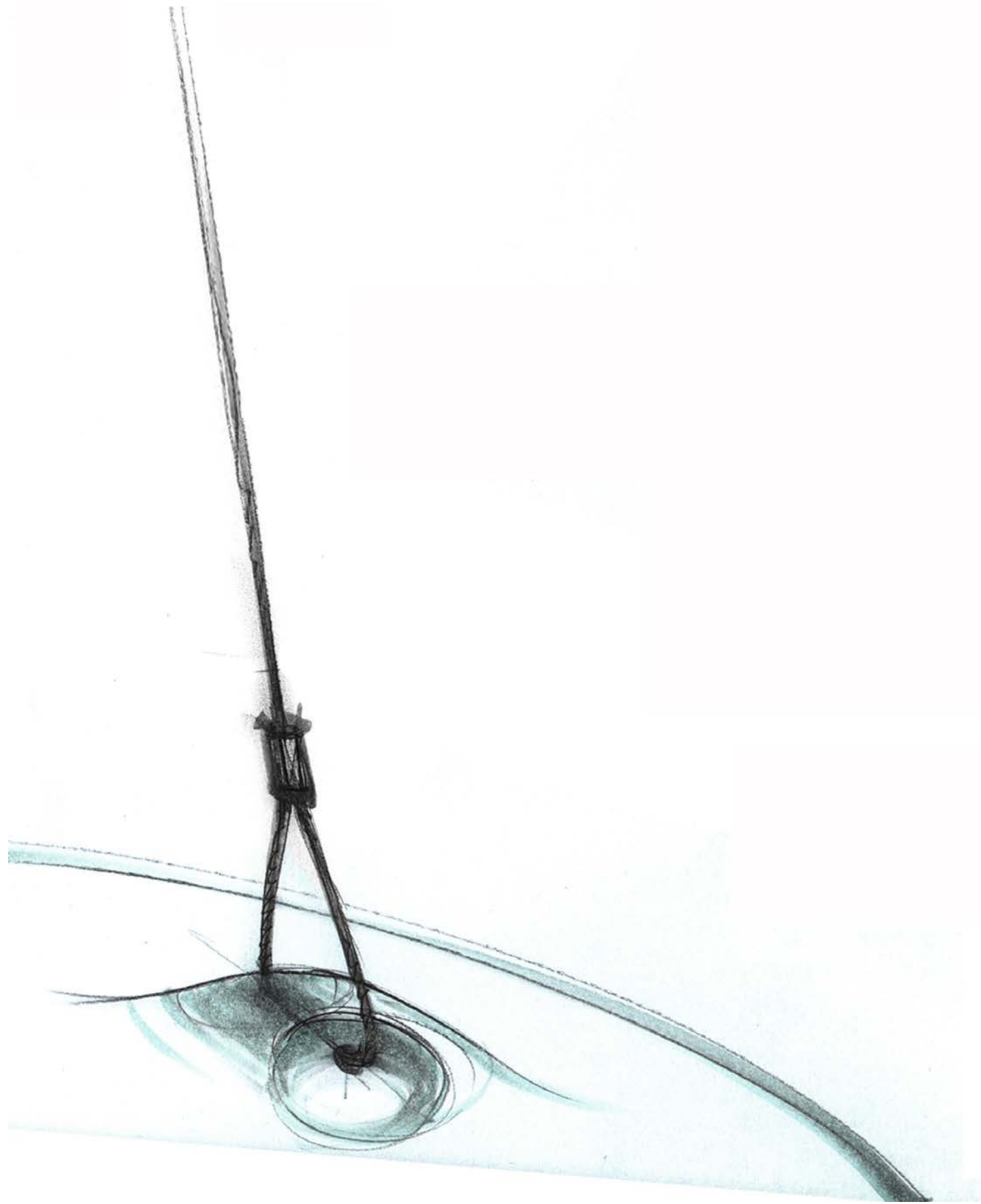

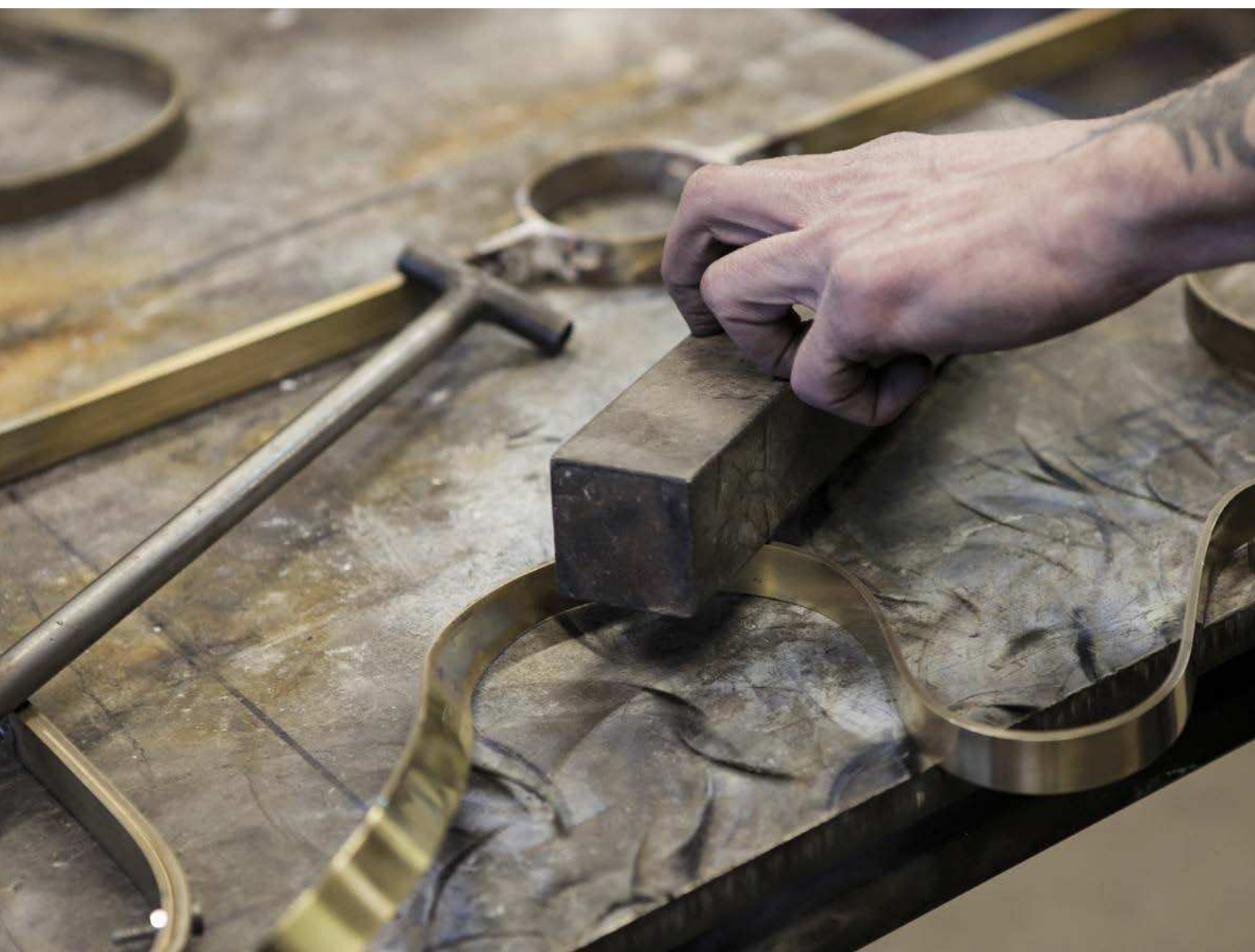

herit-
age





sculp-
tural

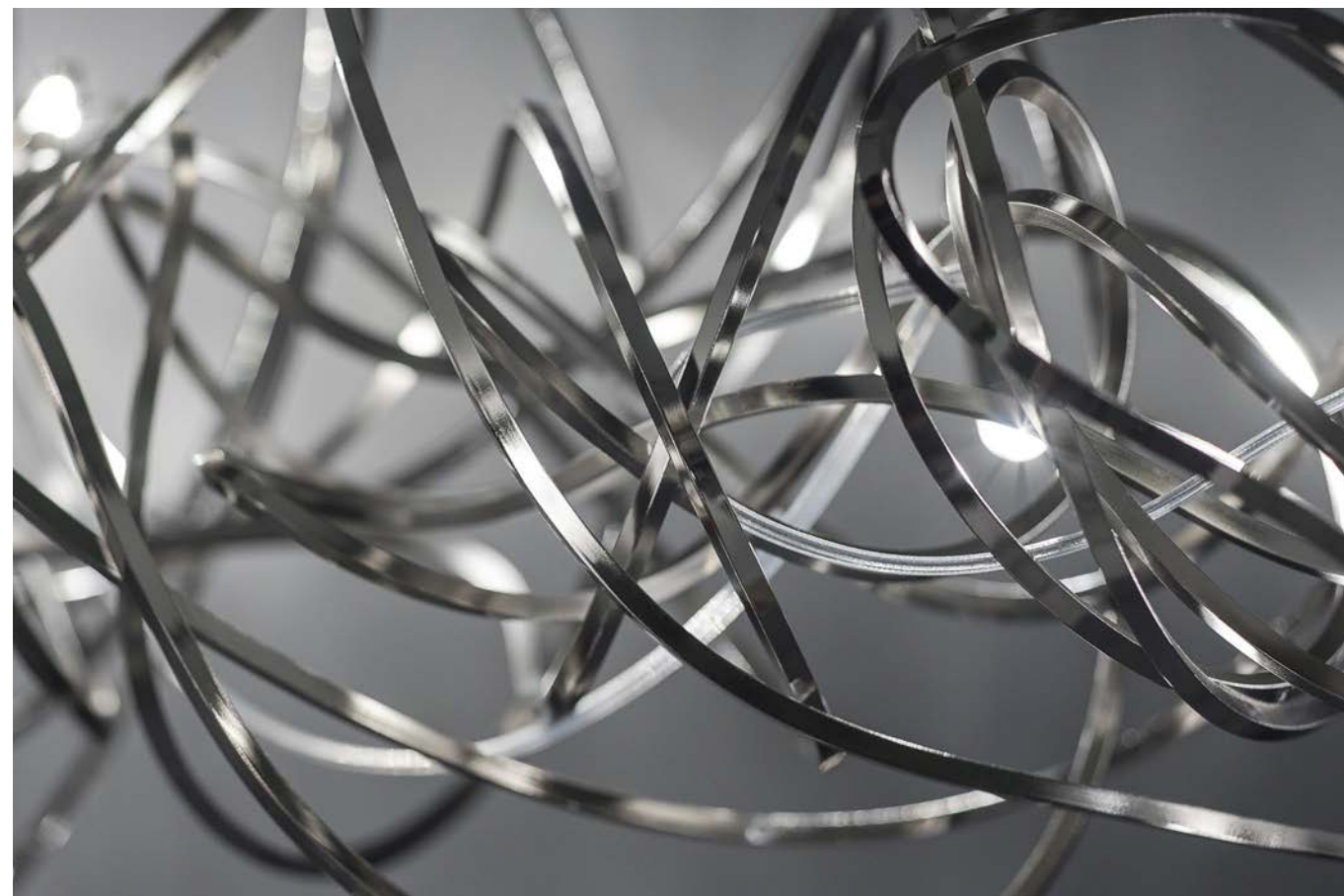



contem-
porary





hand-
made





ele-
gan-
ce





e-
motion







Argent, mon bijou | design Dodo Arslan



new





Lisa Licitra Ponti

Gio Ponti

FRANK LLOYD WRIGHT
/ CAPOLAVORI



Our newest addition to our Argent collection, Argent, mon bijou lets you take designer Dodo Arslan's iconic light sculpture with you wherever you go. Thanks to an innovative, rechargeable, and cordless technology, and a smaller, lightweight design, mon bijou is an elegant portable lighting solution. Like the other entries in our Argent collection, mon bijou is constructed of metal discs that have been meticulously joined by hand by Terzani's Italian craftsmen. Once lit, the multiple, angled surfaces of the discs emanate a soft, shimmering glow.

Take me wherever you want. Make mon bijou the centerpiece for a sophisticated dinner. Relax on your sofa as you bathe in its enchanting light. Or place it on your bedside table to spark romance. Regardless of whether you're entertaining or just looking to enhance your space, mon bijou makes it easy to quickly change the mood no plugs or wires needed.

Argent, mon bijou is available in stainless steel, gold plated, rose gold plated, and champagne plated finishes. Design Dodo Arslan.



EVERYDAY LIFE







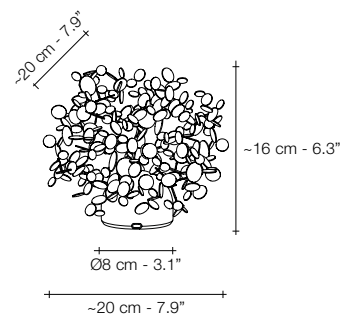

N88B



STAINLESS
STEEL



GOLD
PLATED |
PVD COATING



ROSE GOLD
PLATED |
PVD COATING

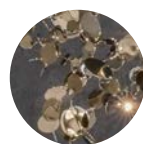

CHAMPAGNE
PLATED |
PVD COATING

LIGHT SOURCE

N88B



Replaceable
LED module
3000K

1,4W
max
210 lm

120V | 230V

Integrated 4 steps dimmer





Stanley, journey beyond the stars | design Dodo Arslan

new





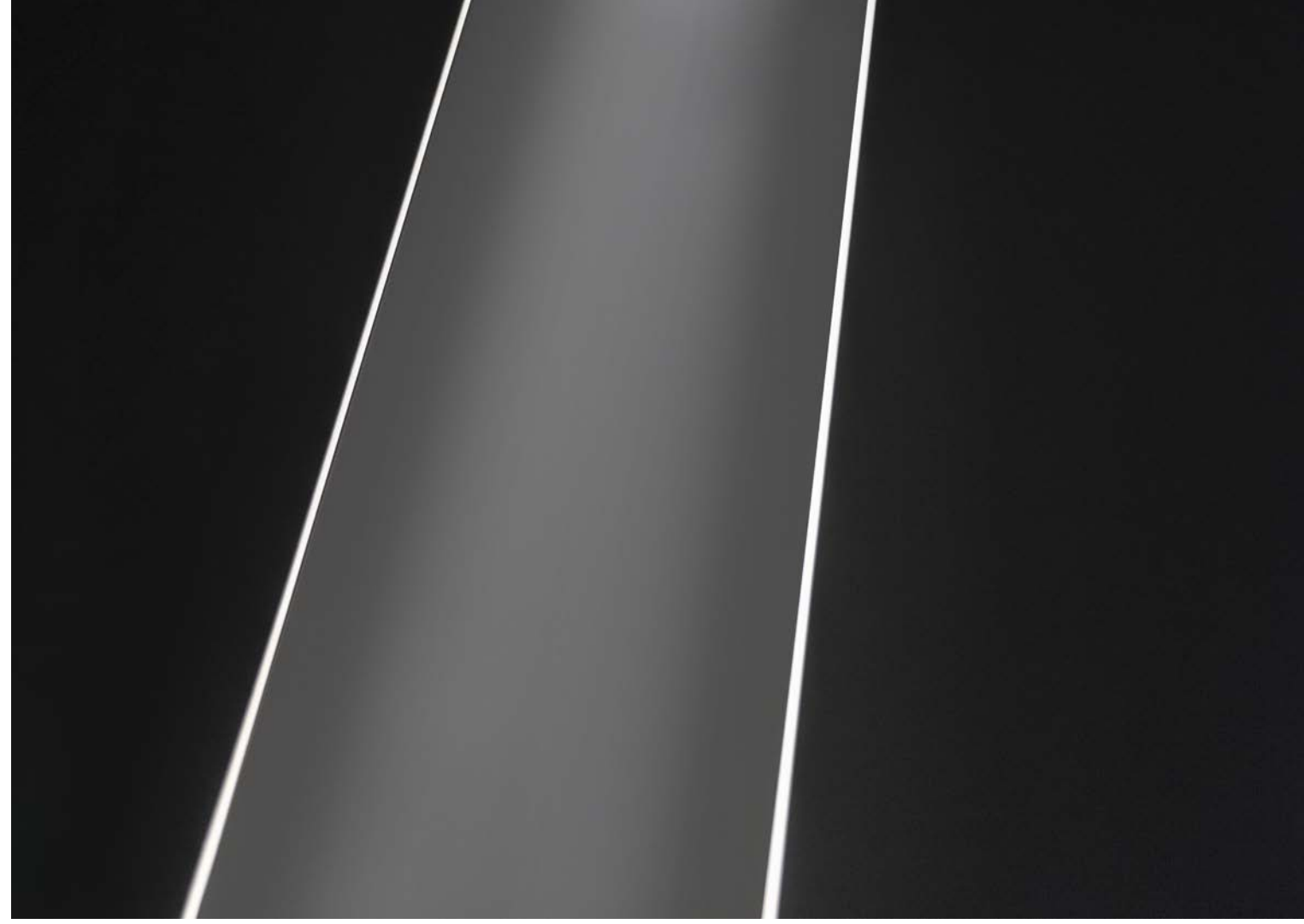



Capturing the mystery, power, and wonder of the stars, this new floor lamp from Dodo Arslan conjures the natural beauty of space and mankind's fascination with the heavens. Blades of crystalline light travel through a field of stars, creating a deep, rich, and nuanced viewing experience. Stanley's multiple perspectives create a cosmic vision with infinite depth. An homage to the genius of Stanley Kubrick and his masterpiece, *2001: A Space Odyssey*, Arslan's design aims to open doors to new galaxies. Through recreating the mysteries of our universe, Stanley captures the sense of awe that continues to compel artists, scientists, and dreamers to look to the sky for answers and inspiration. Staying in accord with the vibrancy of space, Stanley offers a series of chromatic variations which can be customized creating a unique, tonal experience. Design Dodo Arslan.

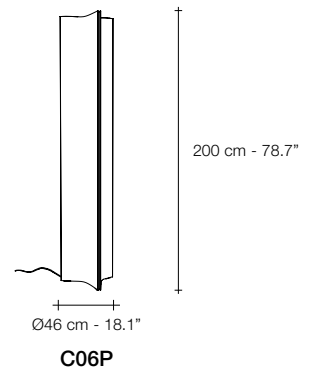



LIGHT SOURCE

120V | 230V

 Top:
 Integrated replaceable LED | 21W | 2875 lm
 +
 Edges:
 Integrated replaceable LED | 3x39W | 12875 lm
 Total 138W | 15750 lm | 3000K | CRI>80

Casambi technology | Xpress wireless switch
 Each light source can be dimmed independently or in programmable groups.
 Light sources are replaceable.



Collections

Epoque, Cyclical *Light.*

Epoque is a light sculpture designed to study chiaroscuro and volumes. The result is a modern expression of these Renaissance-era techniques in a stunning chandelier. Composed of curved, organic lines, Epoque's frame is made of flexible and durable brass metal, suspended by metal chains. Two bands of metal, a central elongated section and an external band of wide arcs, allows the light to envelop a room in reflections of soft light. Epoque has attracted attention from those in the design community with discerning tastes. Epoque is available in nickel, black nickel, gold and bronze plated finishes. Design Stefano Papi & Saviz Yaghmai.





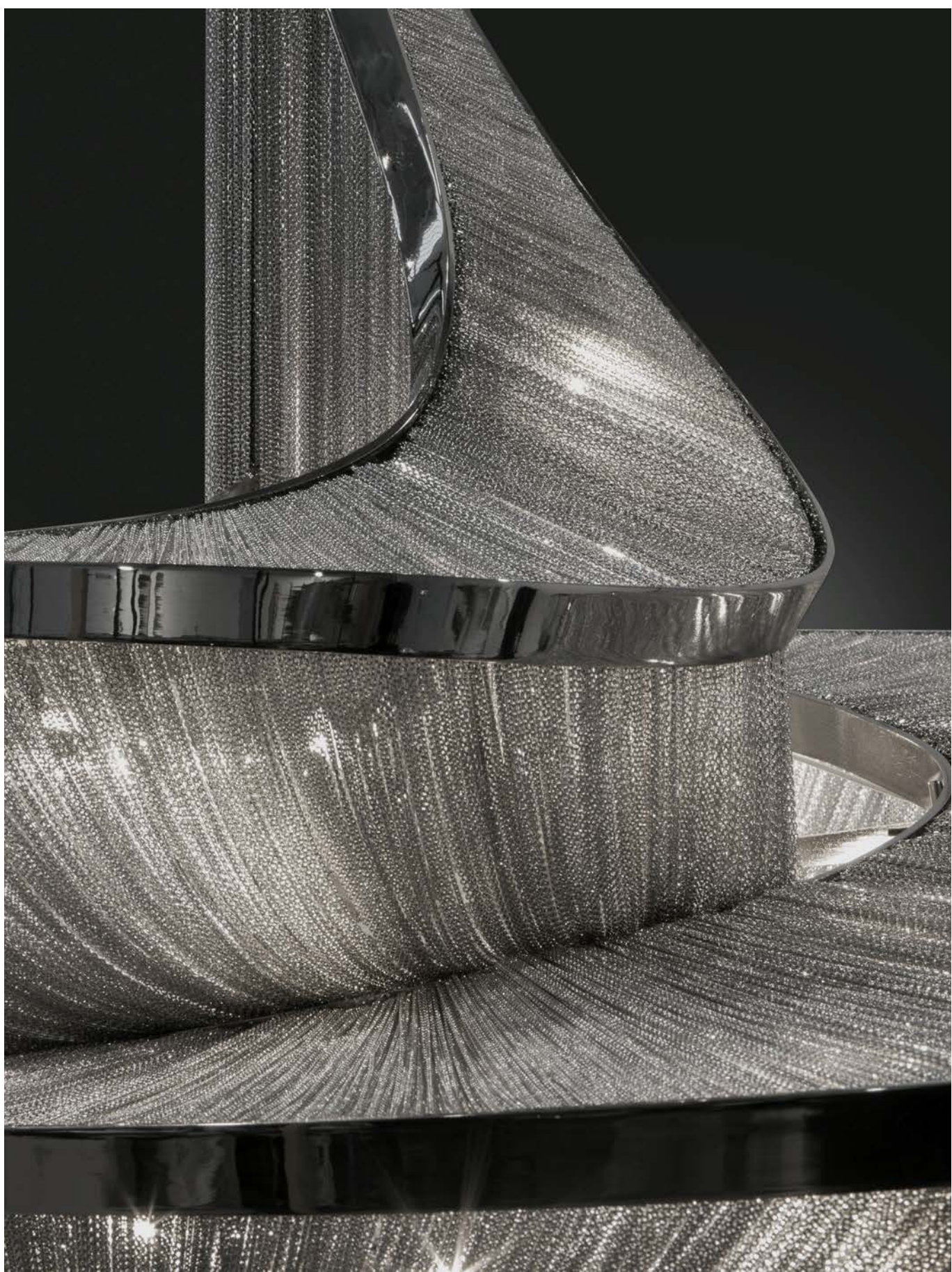



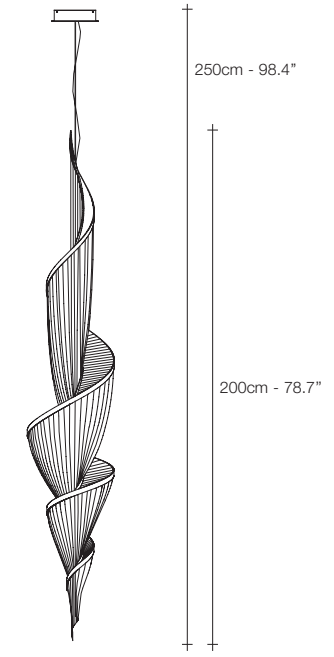

Ø35cm - 13.8"

G91S

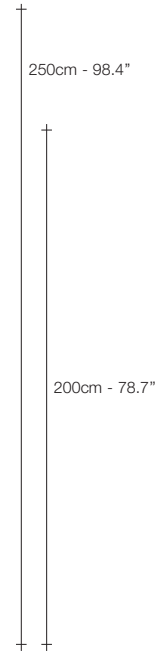

250cm - 98.4"

200cm - 78.7"

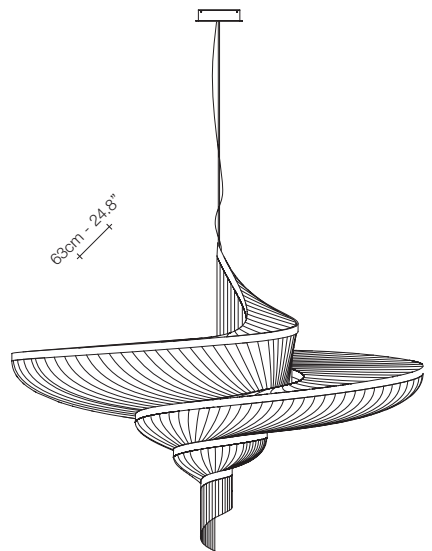

136cm - 53.5"

G90S

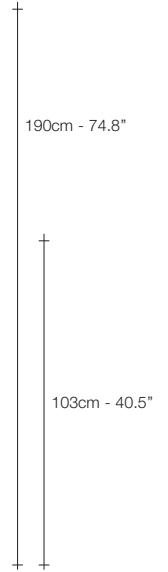

190cm - 74.8"

103cm - 40.5"

63cm - 24.8"



NICKEL



BLACK NICKEL



BRONZE



GOLD PLATED

	LIGHT SOURCE	G91S	G90S
230V	Replaceable LED module	12x2,1W	20x2,1W
	3000K	2328lm	3880lm
	2700K	2064lm	3440lm
	Dimmable	0/1-10V PUSH/DALI	PUSH DALI
120V	Replaceable LED module	12x2,1W	20x2,1W
	3000K	2328lm	3880lm
	2700K	2064lm	3440lm
	Dimmable	0/1-10V PUSH/DALI	1-10V PWM 10-100kΩ

Epoque can be manufactured to work with 3000K or 2700K LED. Different dimming options on request



Atlantis, a precious *wave.*

Seemingly alive, Atlantis' shimmering light creates a vibrant source of energy. Its mesmerizing, organic effect is created by hundreds of illuminated lengths of draped, metal chain. Like water in the ocean, Atlantis' chains appear liquid, cascading over its gloss nickel bands and falling down towards the abyss before turning back into itself. Atlantis is composed of almost three miles of metal chain, meticulously hand-crafted by master Italian artisans. Atlantis is available in nickel, black nickel, bronze, gold, champagne and brushed champagne plated finishes. Design Barlas Baylar. Made in Italy.











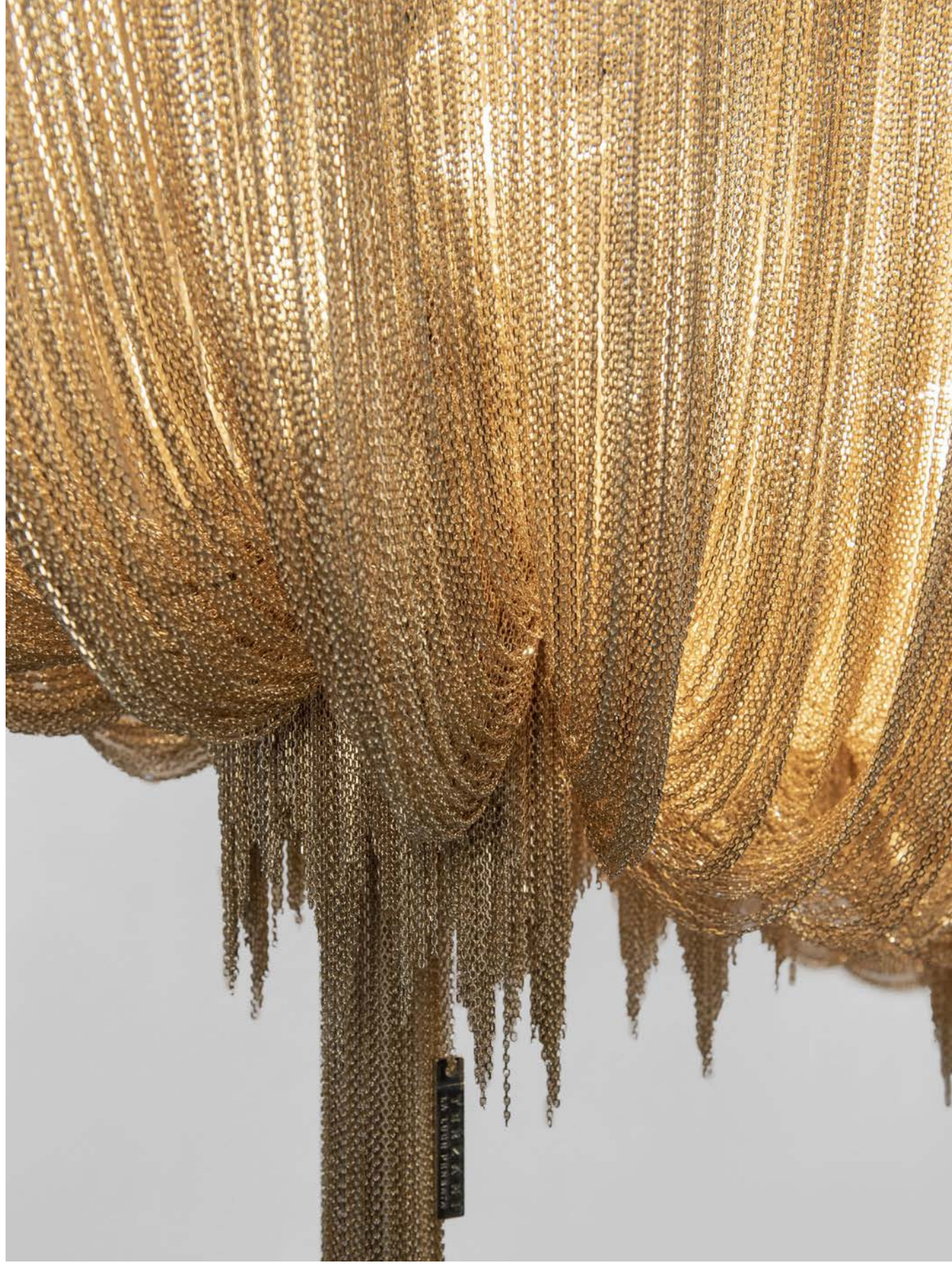









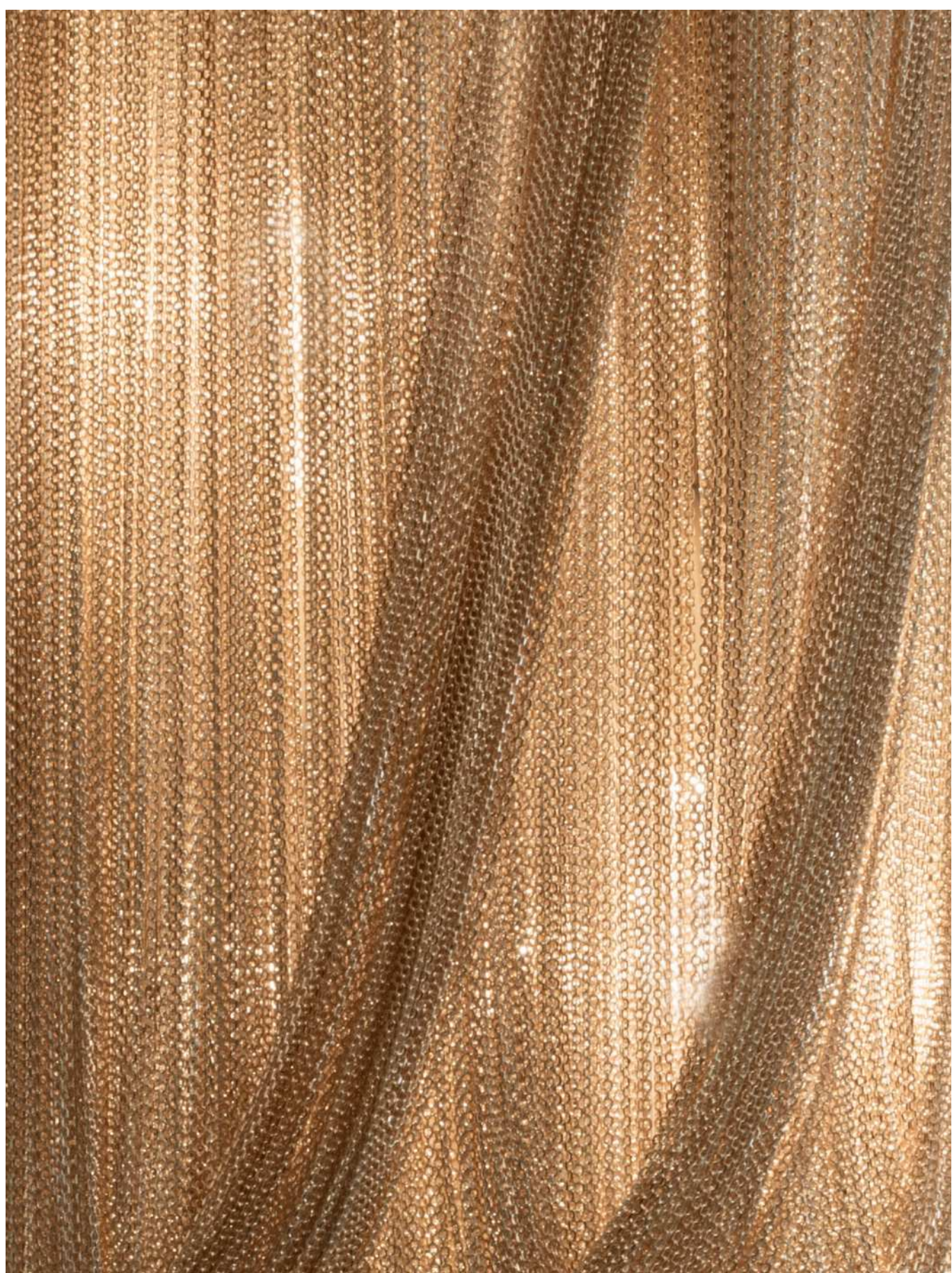

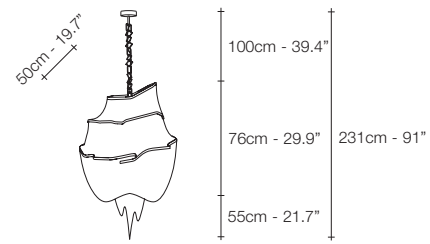

A13S

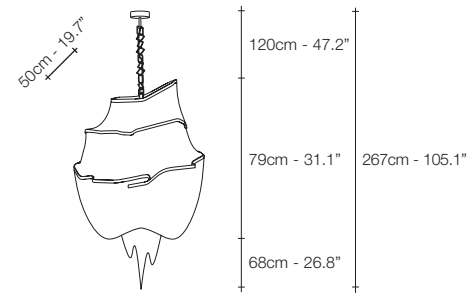

A14S

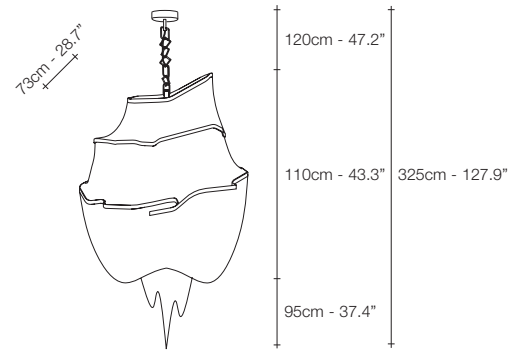

A15S

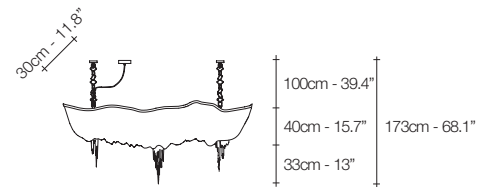

A18S

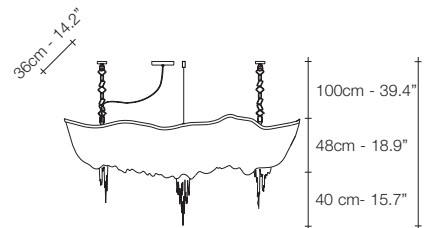

A17S

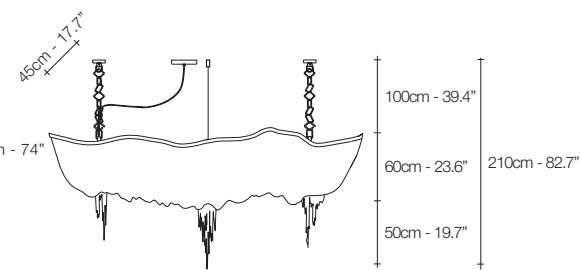

A16S

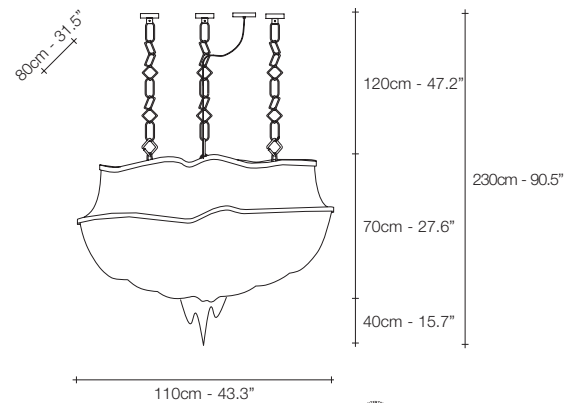

J01S

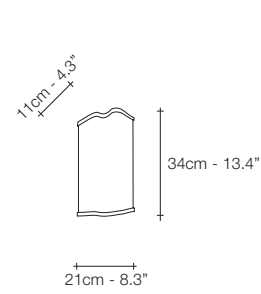

J04A

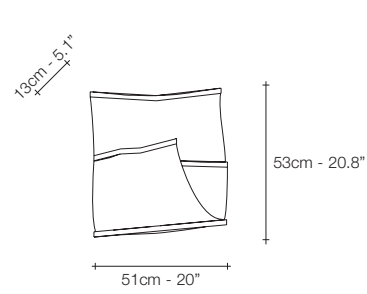

J03A



NICKEL



BLACK NICKEL



BRONZE



GOLD PLATED



CHAMPAGNE



BRUSHED CHAMPAGNE

	LIGHT SOURCE	A13S	A14S	A15S	A18S	A17S	A16S	J01S	J04A	J03A
230V	E14 LED	6x6W	8x6W	8x6W	8x6W	10x6W	10x6W	8x6W	2x6W	4x6W
	Dimmable	✓	✓	✓	✓	✓	✓	✓	✓	✓
120V	E12 LED	6x5.5W	8x5.5W	8x5.5W	8x5.5W	10x5.5W	10x5.5W	10x5.5W	2x5.5W	4x5.5W
	Dimmable	✓	✓	✓	✓	✓	✓	✓	✓	✓



Stream, Iridescent *Light.*

Another stunning design from Christian Lava, Stream is an impressive presence in any room. Like Christian's other work for Terzani, Etoile and Moiré, Stream's design exploits the physical characteristics of the materials used to envelop a room in a unique, immersive light. Here, over seven kilometers of metal chain appear to flow down from the undulating, nickel-plated frame. These cascading tiers project a streaking, yet tranquil, shadow throughout the room. Available in nickel, black nickel and gold plated finishes. Design Christian Lava. Made in Italy.











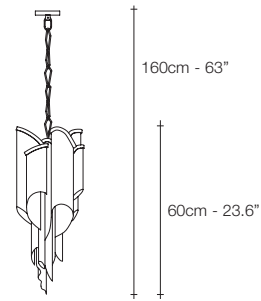

J54S

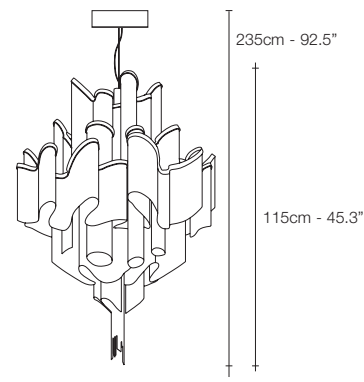

J51S

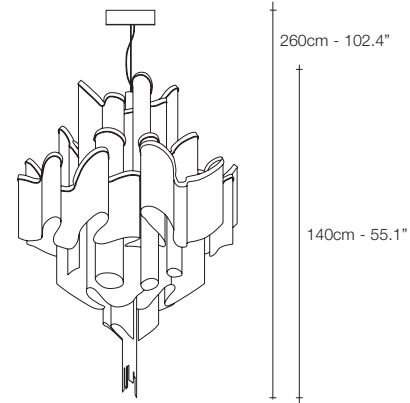

J50S

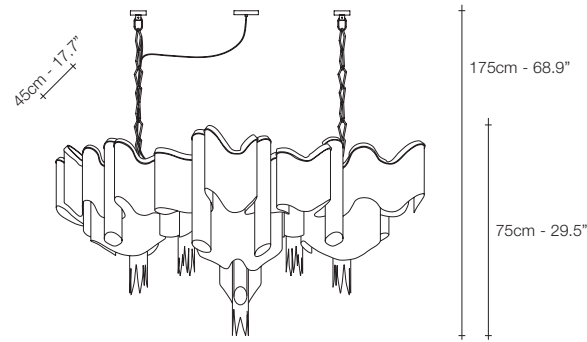

J52S

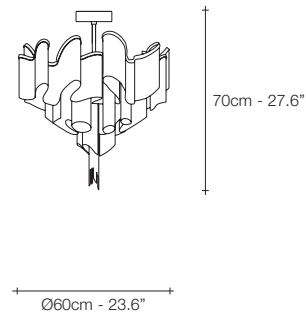

J70L

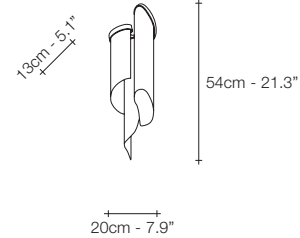

J60A

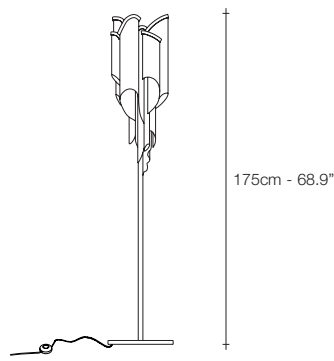

J65P



NICKEL



BLACK NICKEL



GOLD PLATED

LIGHT SOURCE		J51S	J50S	LIGHT SOURCE			J54S	J52S	J70L	LIGHT SOURCE		J60A	J65P		
230V		E14 LED GU10 LED	18x4W 5W	20x4W 5W	230V		G9 LED GU10 LED	4x3,5W 5W	12x3,5W 3x5W	8x3,5W 5W	230V		E14 LED	2x6W	6x6W
	Dimmable	✓	✓	Dimmable	✓	✓	✓	✓	✓	✓	✓	✓	✓	✓	✓
120V		E12 LED GU10 LED	18x4W 6W	20x4W 6W	120V		G9 LED GU10 LED	4x4W 6W	12x4W 3x6W	8x4W 6W	120V		E12 LED	2x5.5W	6x5.5W
	Dimmable	✓	✓	Dimmable	✓	✓	✓	✓	✓	✓	✓	✓	✓	✓	✓



Volver, Breath of new *Light.*

At Terzani, we are fortunate to work with some of the brightest young stars in Italian design. For Volver, designer Diego Bassetti and architect Andrea Panzieri of Studio 14, protégés of Bruno Rainaldi, applied their multidisciplinary approach to create Terzani's first LED suspension light. This geometric design combines thin metal chains with the latest in LED technology to create a light that is both elegant and modern. A breath of new light, Volver melds technology and art to achieve a new level of luxury. Available in nickel, black nickel, bronze and gold plated and in a circular variation. Design Studio 14. Made in Italy.





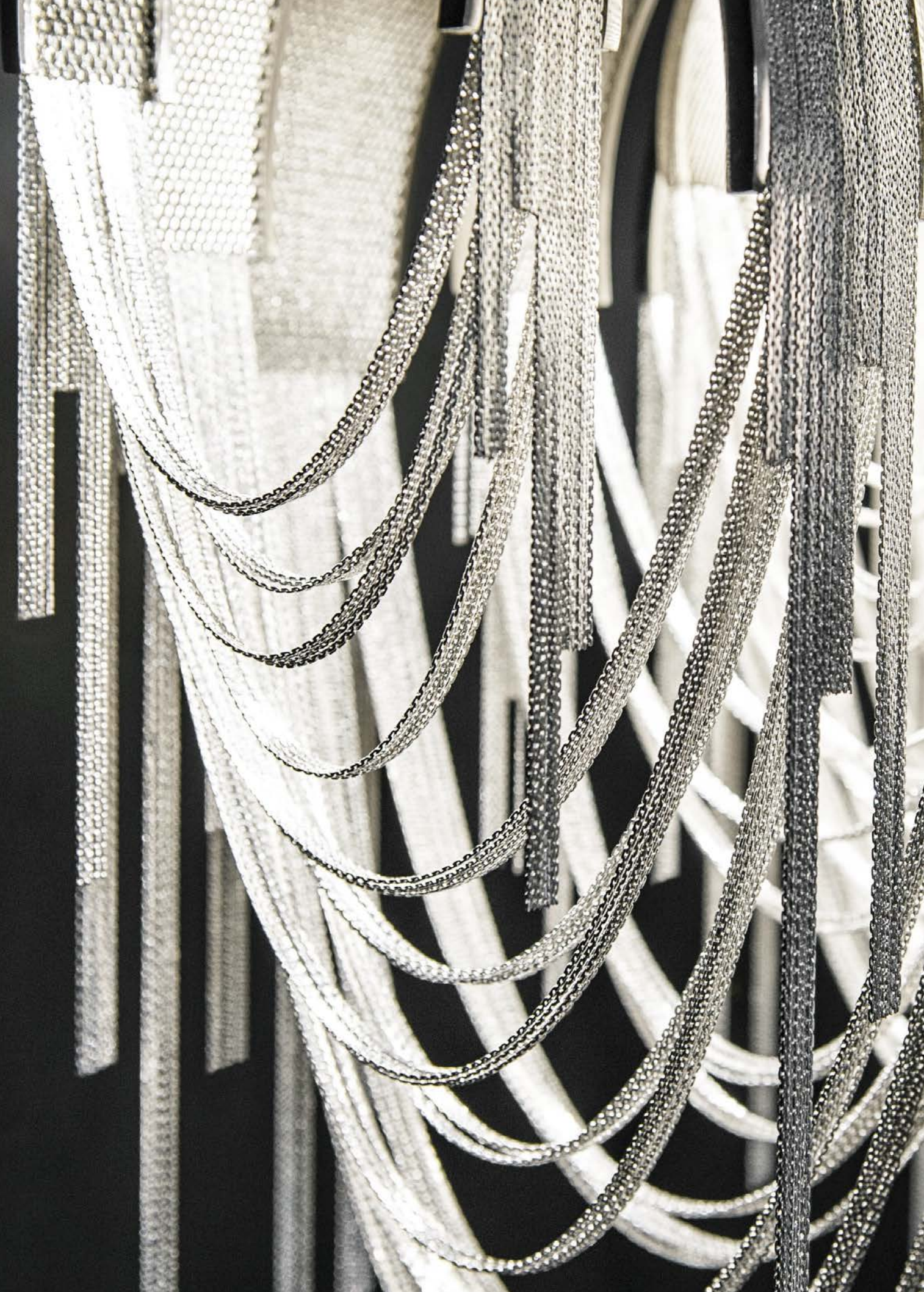



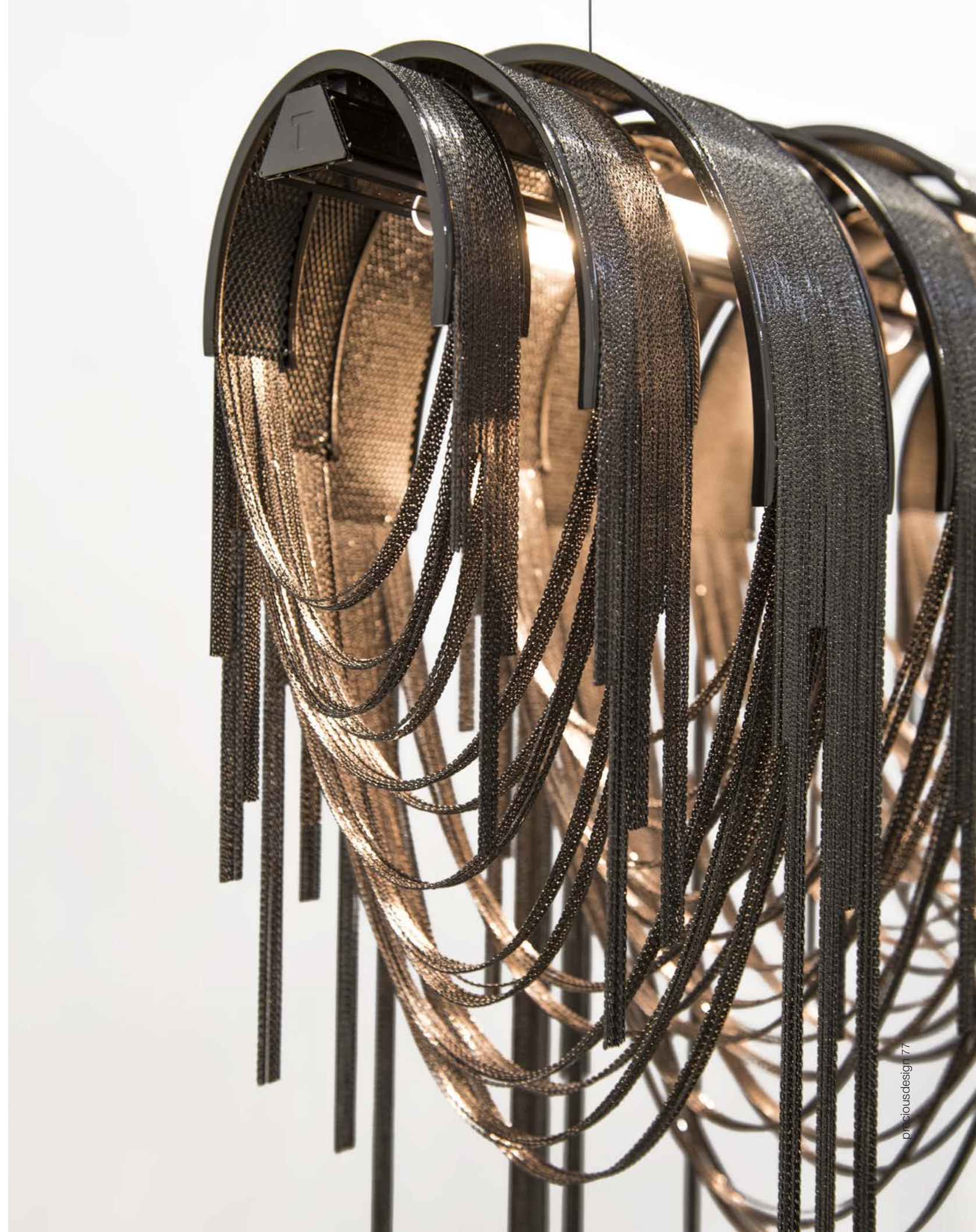

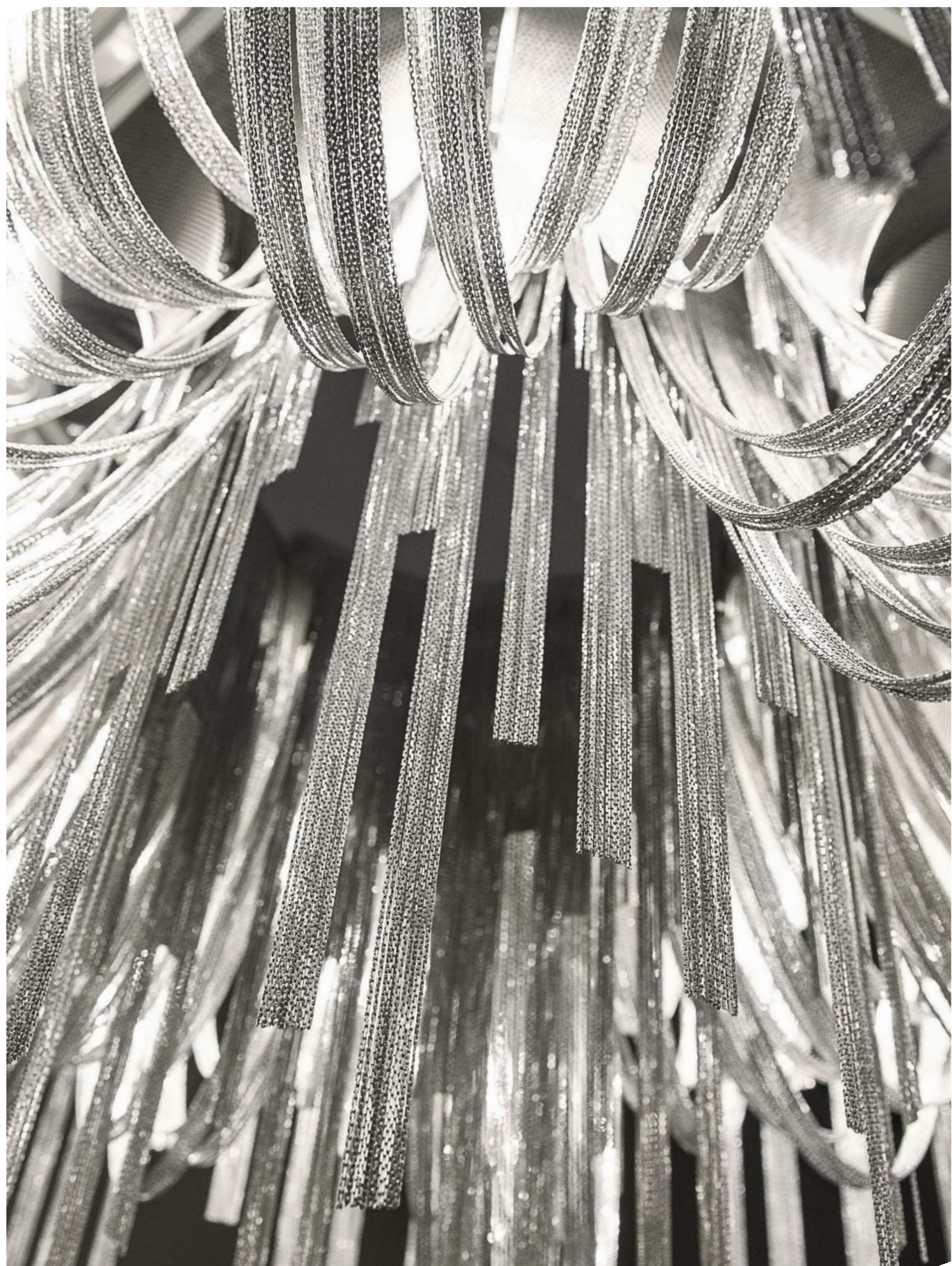

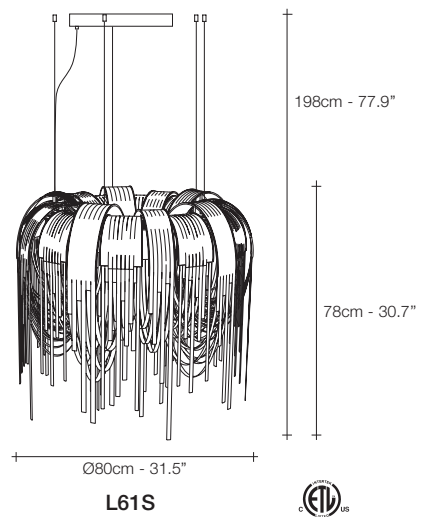
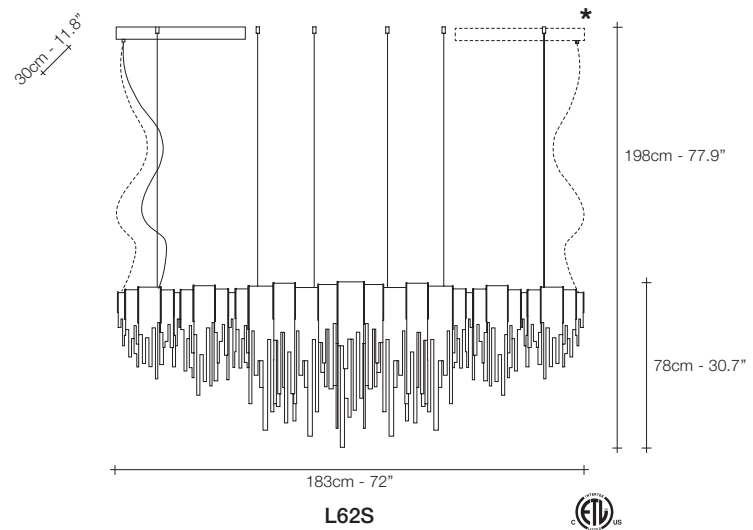
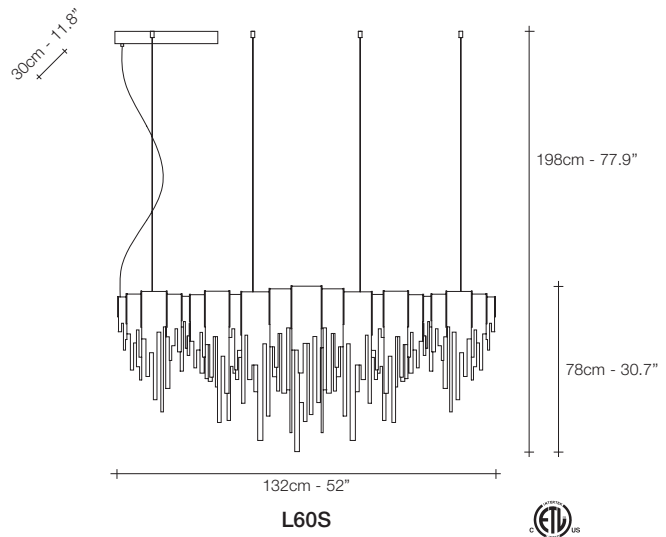
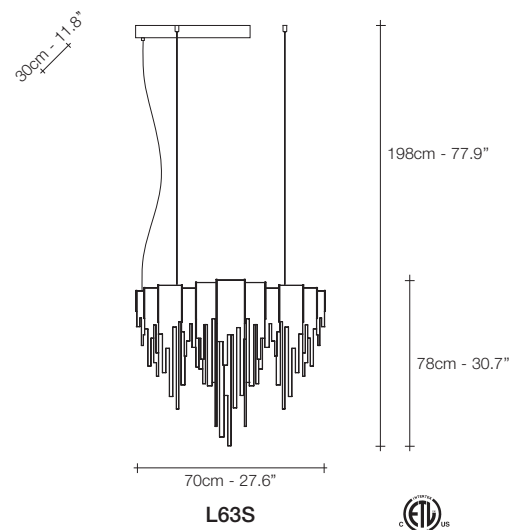

	LIGHT SOURCE	L63S	L60S	L62S	L61S
230V	Replaceable LED module	7x4,5W	10x4,5W	20x4,5W	10x4,5W
	CRI 90 3000K 2700K	4632lm 4200lm	6617lm 6000lm	13234lm 12000lm	6617lm 6000lm
	Dimmable	0-10V PWM PUSH/DALI	0-10V PUSH/DALI	0-10V PUSH/DALI	0-10V PUSH/DALI
120V	Replaceable LED module	7x4.5W	10x4.5W	20x4.5W	10x4.5W
	CRI 90 3000K 2700K	4632lm 4200lm	6617lm 6000lm	13234lm 12000lm	6617lm 6000lm
	Dimmable	1-10V PWM	1-10V PWM	1-10V PWM	1-10V PWM

Volver can be manufactured to work with integrated LED 3000K or 2700K. Different dimming options on request.
 * Only 120V version has two canopies.



Soscik, Classic form, *Modern look.*

Reinventing the classics. With Soscik, Terzani combines traditional, artisan techniques with cutting edge technology to give the traditional chandelier a modern update. Over the plated frame, Soscik creates a dramatic and romantic effect, while still being able to compliment today's modern luxury. Available as a chandelier or a ceiling lamp, Soscik proves that modern design does not have to sacrifice luxury. Available in nickel, bronze, gold and champagne plated finishes. Design Nicolas Terzani. Made in Italy.







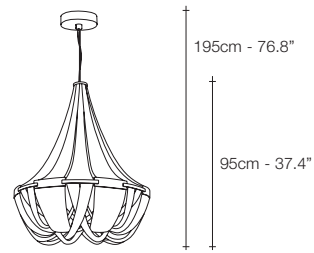

Ø72cm - 28.4"
G55S

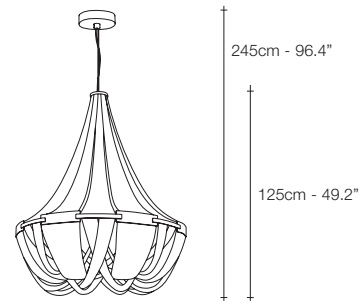

Ø100cm - 39.4"
G56S

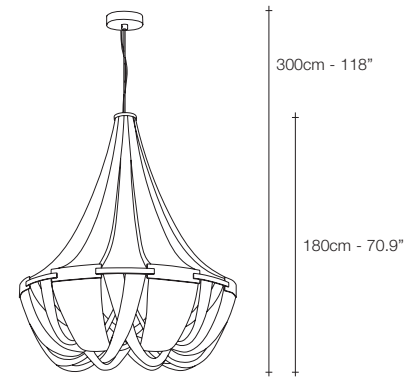

Ø145cm - 57.1"
G57S



Ø72cm - 28.4"
G60L



Ø100cm - 39.4"
G61L



Ø145cm - 57.1"
G62L



NICKEL



BRONZE



GOLD PLATED

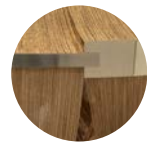

CHAMPAGNE

LIGHT SOURCE		G55S	G56S	G57S	G60L	G61L	G62L
230V	G9 LED	8x3,5W	12x3,5W	14x3,5W	8x3,5W	10x3,5W	12x3,5W
	Dimmable	✓	✓	✓	✓	✓	✓
120V	G9 LED	8x4W	12x4W	14x4W	8x4W	10x4W	12x4W
	Dimmable	✓	✓	✓	✓	✓	✓



Argent, a precious *cloud.*

With this suspension light, designer Dodo Arslan creates a shimmering cloud. Argent consists of metal discs that have been meticulously shaped by hand by Terzani craftsmen into clusters. Once lit, the multiple, angled surfaces of the discs emanate a soft, shimmering glow. Argent is available in stainless steel, gold, rose gold and champagne plated finishes. Black nickel is available on request. Design Dodo Arslan. Made in Italy.

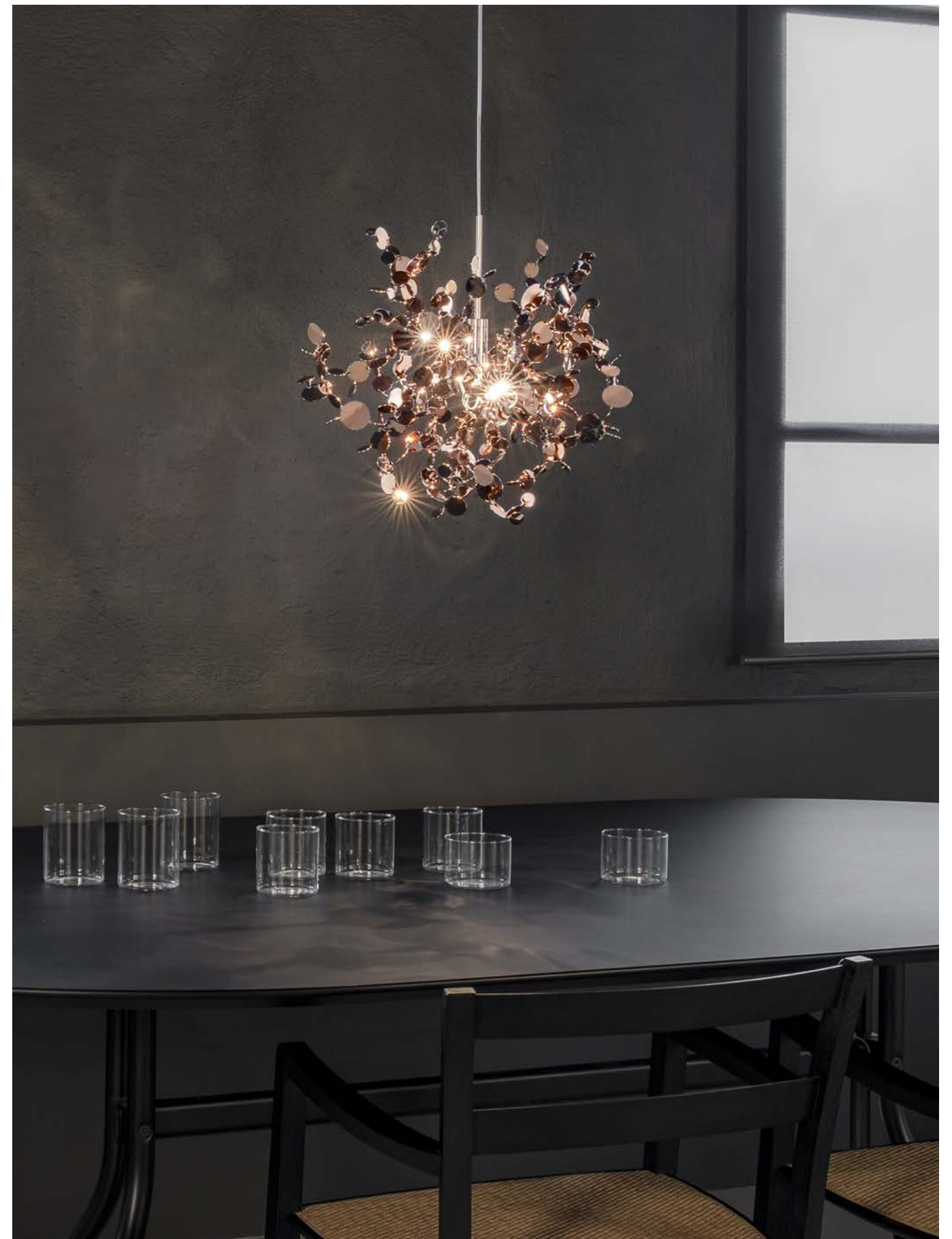

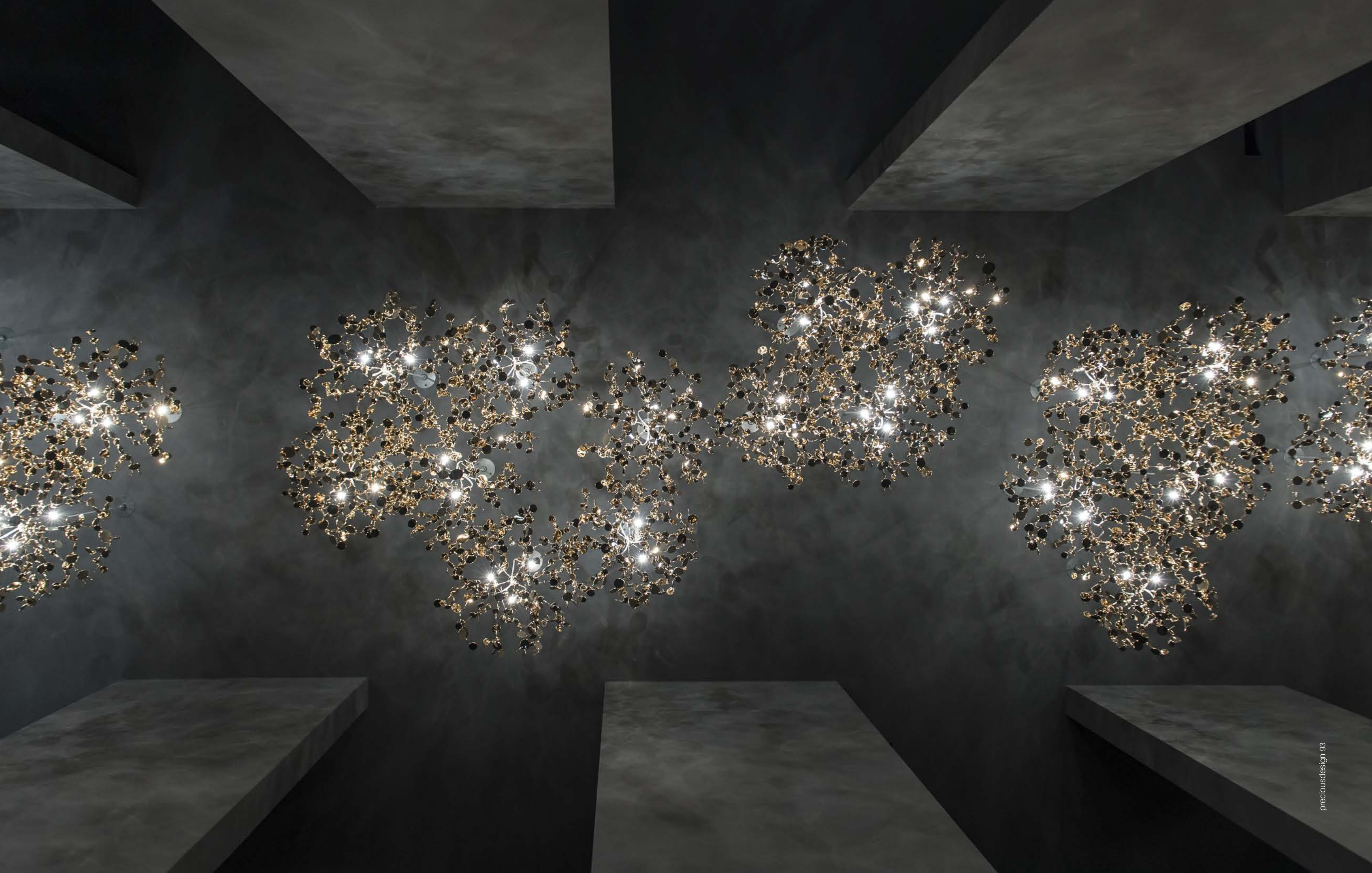





















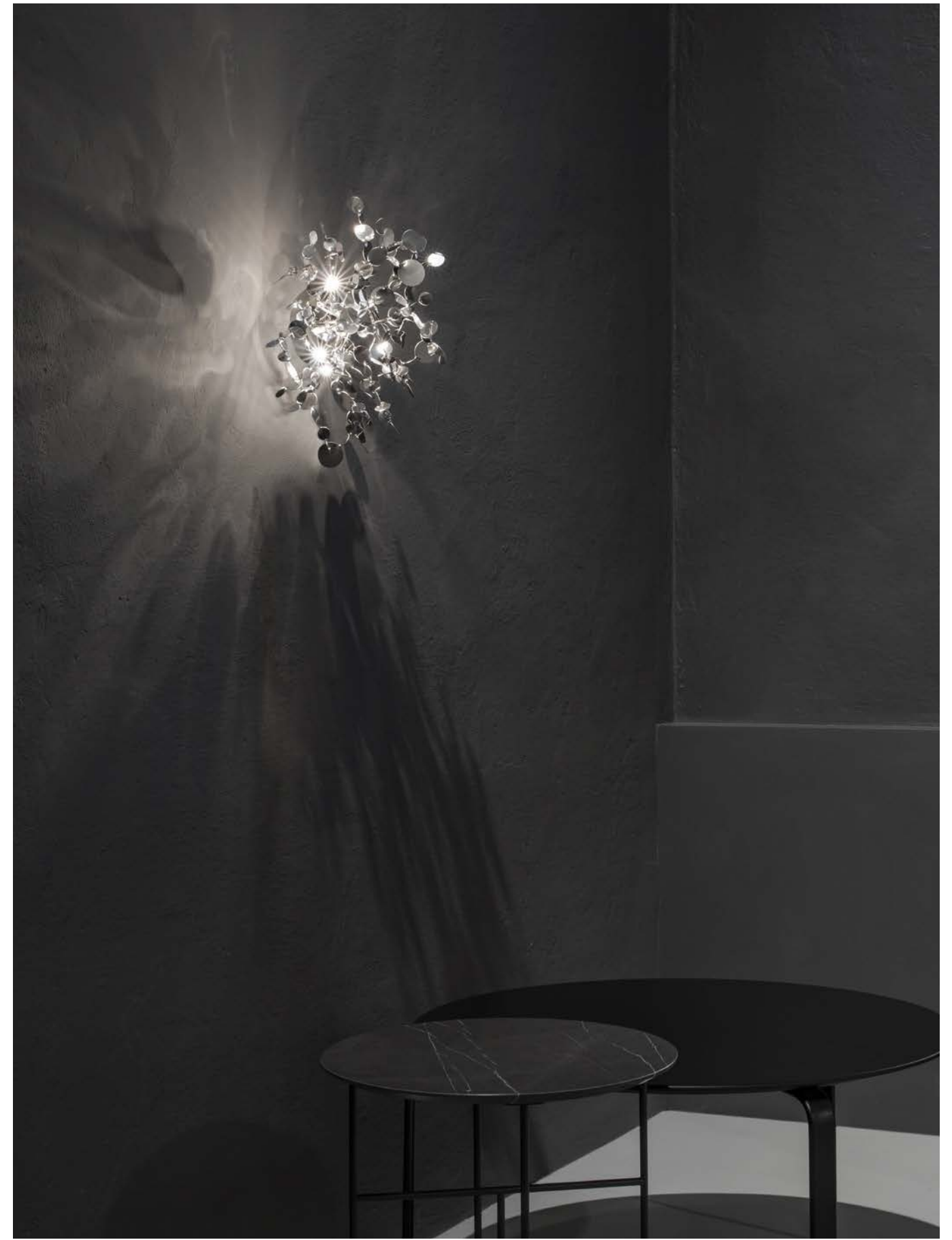





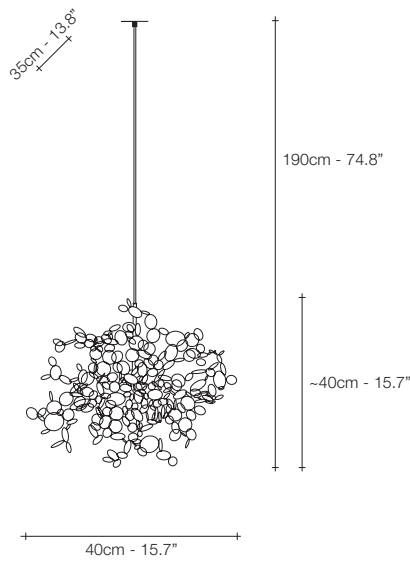

N90S KK
WHITE DISC

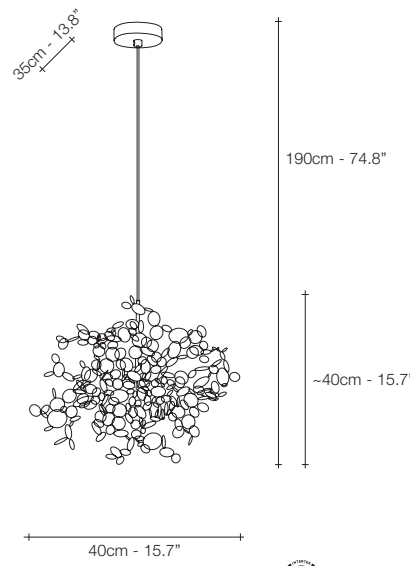

N90S

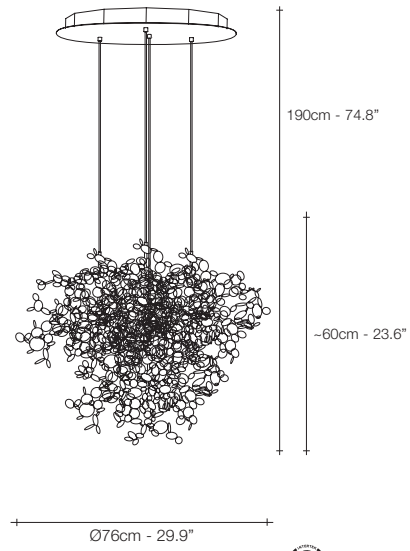

N91S

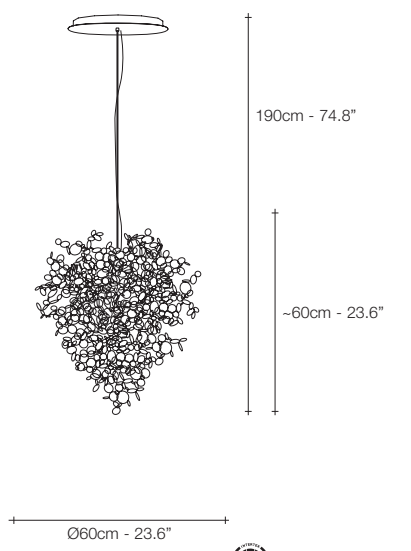

N95S

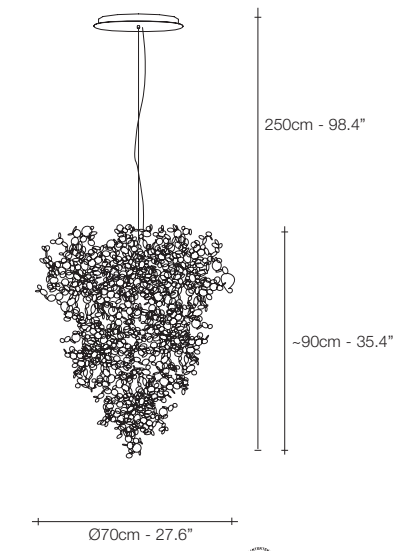

N93S

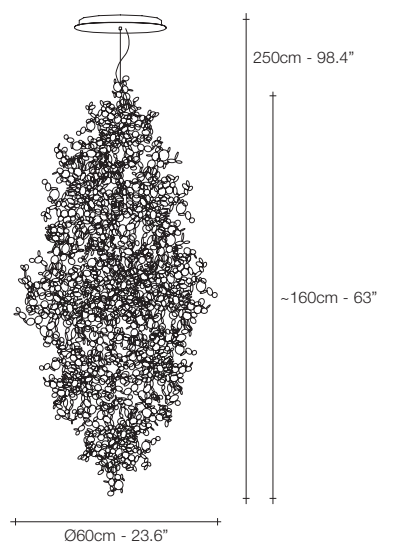

N94S

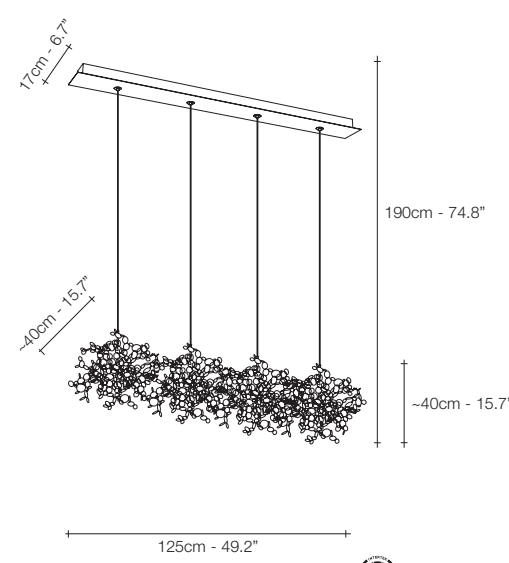

N92S

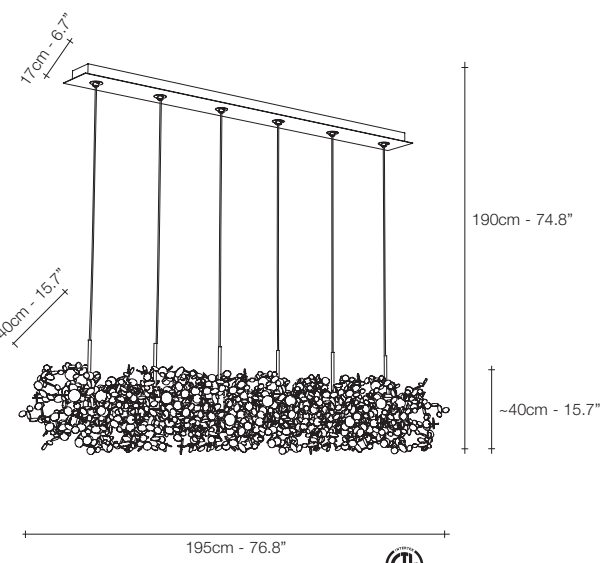

N89S

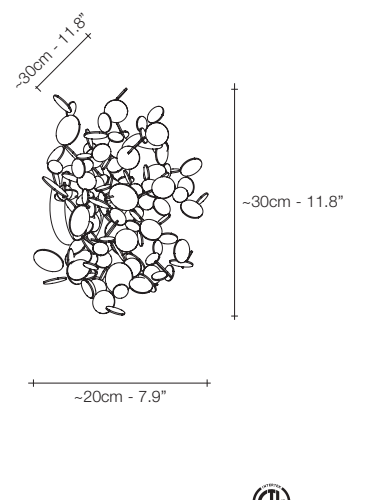

N97A

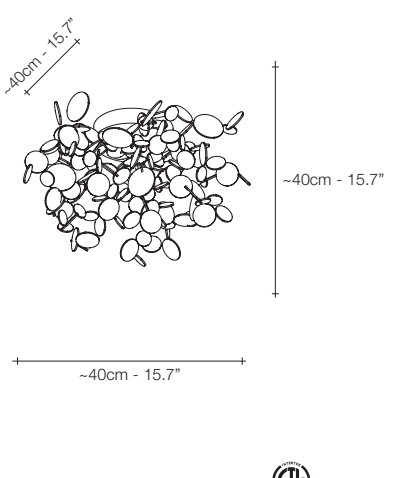

N99L

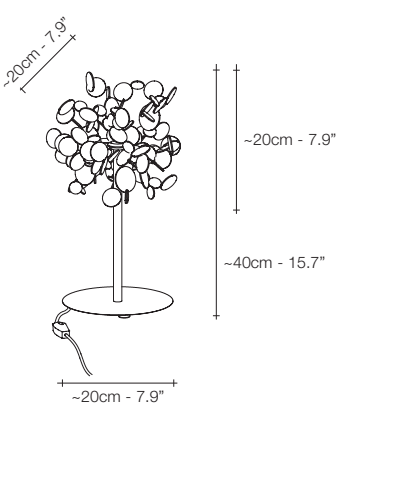

N98B

N/A in North America



	N90S KK	N90S	N91S	N92S	N89S	N97A	N99L	N98B		N95S	N93S	N94S	
230V									230V				
	G4 HALOGEN G4 LED	3x20W 3x2W	3x20W 3x2W	12x20W 12x2W	12x20W 12x2W	18x20W 18x2W	3x20W 3x2W	3x20W 3x2W		Replaceable LED module 3000K 2700K	6x2,1W 1698lm 3036lm	12x2,1W 3396lm 3036lm	18x2,1W 5094lm 4554lm
	Dimmable	IGBT 0/1-10V 10-100kΩ PUSH/DALI	IGBT TRIAC DALI	IGBT 0/1-10V PWM 10-100kΩ PUSH/DALI	IGBT 0/1-10V PWM 10-100kΩ PUSH/DALI	IGBT 0/1-10V PWM 10-100kΩ PUSH/DALI	IGBT TRIAC DALI	IGBT TRIAC DALI		Dimmable	0/1-10V PUSH/DALI	1-10V PUSH/DALI	PUSH/DALI
120V									120V				
	G4 XENON G4 LED	3x20W 3x2W	3x20W 3x2W	12x20W 12x2W	12x20W 12x2W	18x20W 18x2W	3x20W 3x2W	3x20W 3x2W		Replaceable LED module 3000K 2700K	6x2.1W 1698lm 1518lm	12x2.1W 3396lm 3036lm	18x2.1W 5094lm 4554lm
	Dimmable	ELV	ELV	ELV	ELV	ELV	ELV	ELV		Dimmable	1-10V PUSH	0/1-10V PUSH/DALI	0/1-10V PUSH/DALI

Argent N93S, N94S, N95S can be manufactured to work with integrated LED 3000K or 2700K. Different dimming options on request.

Mizu, flowing *light.*

Inspired by the tranquil and mesmerizing light refractions created by water, Mizu is a customizable pendant light from Terzani. Like water droplets, no two Mizu are alike, each crystal shape is unique and made meticulously by hand. Using only the clearest crystal, Mizu perfectly emulates water's refraction of light, casting amazing patterns around the room, reminiscent of flowing water. Available in clear, silver dust, gold, cognac and champagne finish. Design Nicolas Terzani. Made in Italy.





























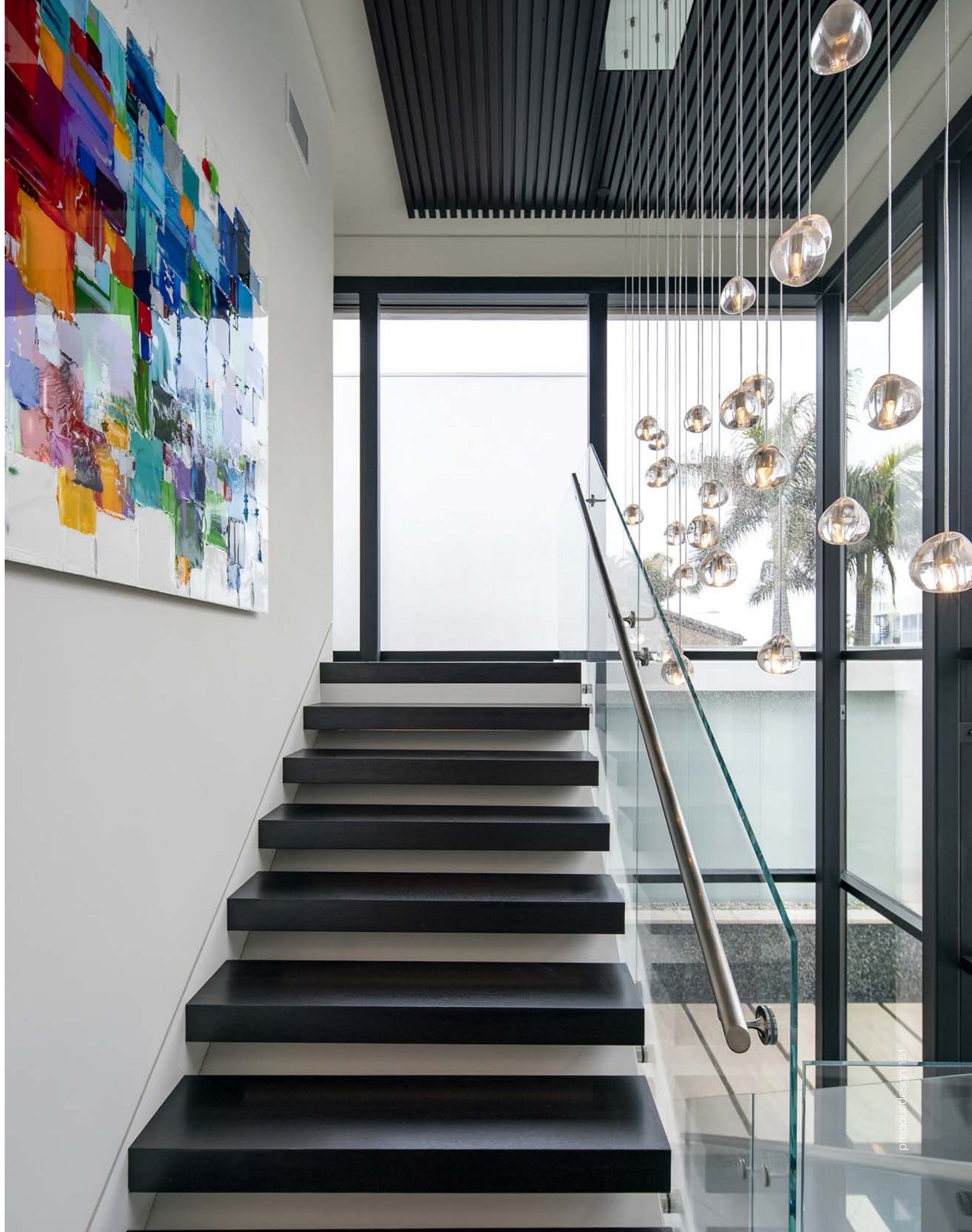

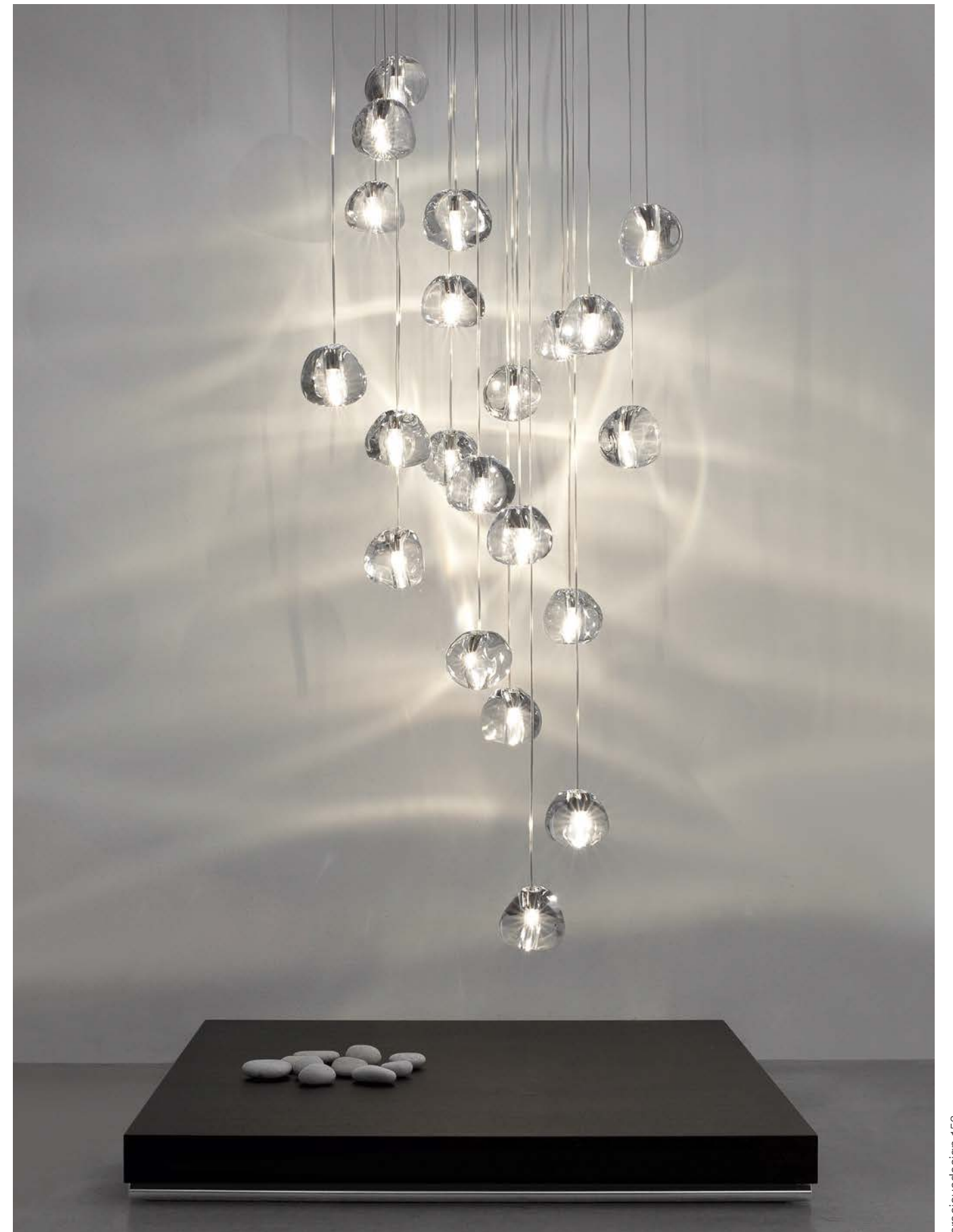

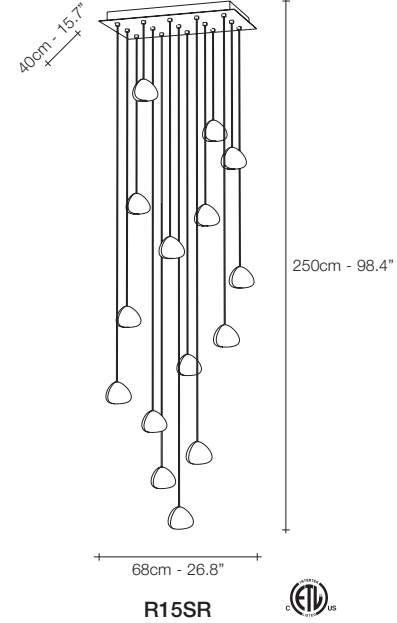
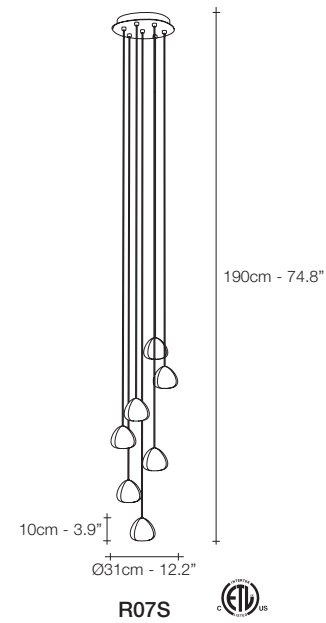
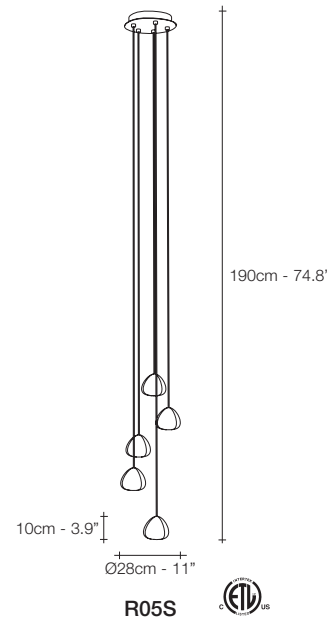
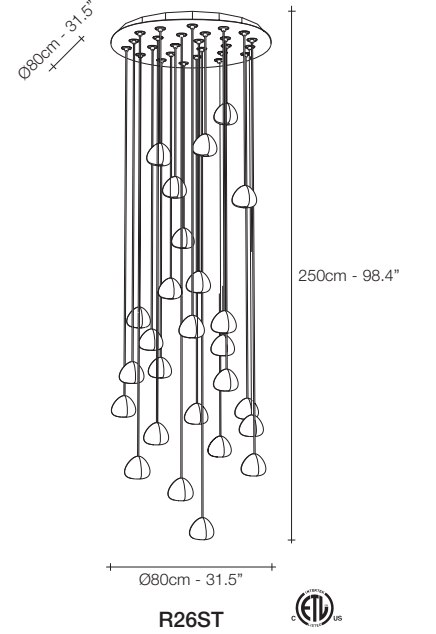
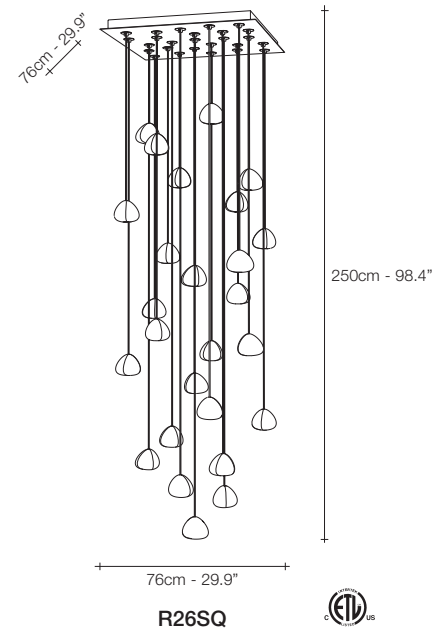
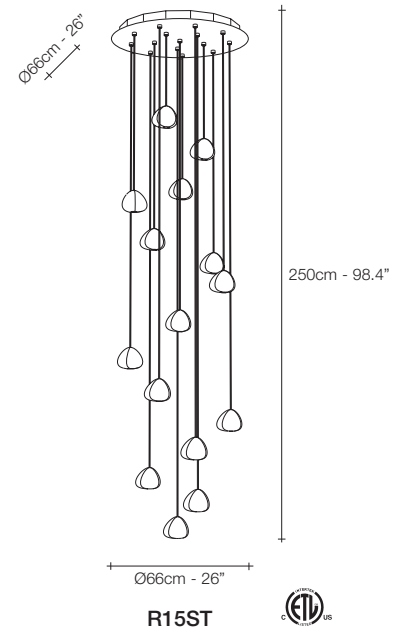
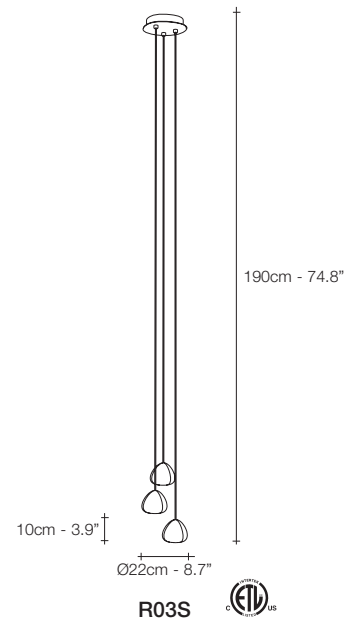
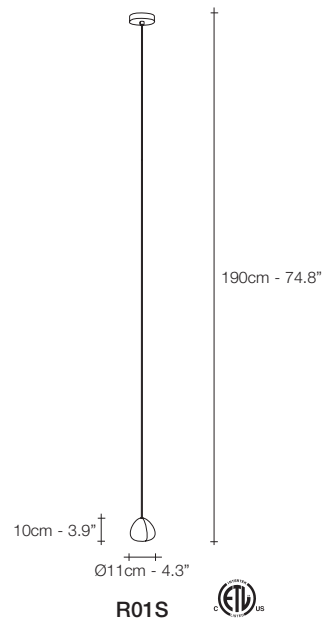
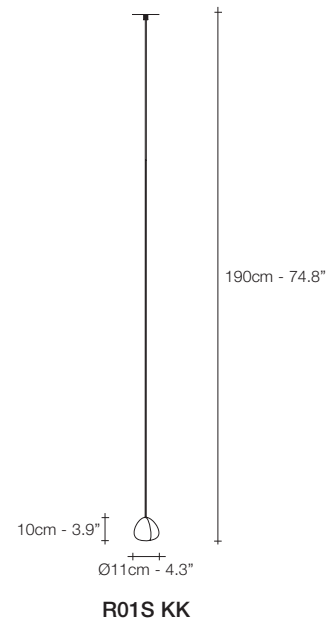

CRYSTAL



CHAMPAGNE CRYSTAL



COGNAC CRYSTAL



SILVER DUST CRYSTAL



GOLD CRYSTAL

	R01S KK	R01S	R03S	R05S	R07S	R15SR	R15ST	R26SQ	R26ST
230V	G4 HALOGEN	10W	3x10W	5x10W	7x10W	15x10W	15x10W	26x10W	26x10W
	G4 LED	2W	3x2W	5x2W	7x2W	15x2W	15x2W	26x2W	26x2W
	Replaceable LED module	1,5W	3x1,5W	5x1,5W	7x1,5W	15x1,5W	15x1,5W	26x1,5W	26x1,5W
		146lm	438lm	730lm	1022lm	2190lm	2190lm	3796lm	3796lm
		129lm	387lm	645lm	903lm	1935lm	1935lm	3354lm	3354lm
	Dimmable	IGBT 10-100kΩ 0/1-10V PUSH/DALI	IGBT 1-10V PUSH/DALI	IGBT 0/1-10V 10V PWM PUSH/DALI	IGBT 0/1-10V PWM PUSH/DALI	IGBT 0/1-10V PWM PUSH/DALI	IGBT 0/1-10V PWM PUSH/DALI	IGBT 0/1-10V PWM PUSH/DALI	IGBT 0/1-10V PWM PUSH/DALI
120V	G4 XENON	10W	3x10W	5x10W	7x10W	15x10W	15x10W	26x10W	26x10W
	G4 LED	2W	3x2W	5x2W	7x2W	15x2W	15x2W	26x2W	26x2W
	Dimmable	ELV	ELV	ELV	ELV	ELV	ELV	ELV	ELV

Mizu can be manufactured to work with integrated LED 3000K or 2700K (not ETL). Different dimming options on request

Manta, Shimmering *Waves.*

Manta is the latest design featuring the distinctive crystal first unveiled in Nicolas Terzani's best-selling Mizu. Collaborating with designer Dodo Arslan, the two imaginative minds created a light featuring sinuous, undulating lines. The results are soft waves of crystal light reminiscent of being underwater. The innovative Manta is made of crystal, with a dimmable integrated LED lamp focused on maximizing the crystal's reflection. Manta's organic form is available in two sizes and can be installed in numerous, customizable arrangements. Design Dodo Arslan & Nicolas Terzani. Made in Italy.





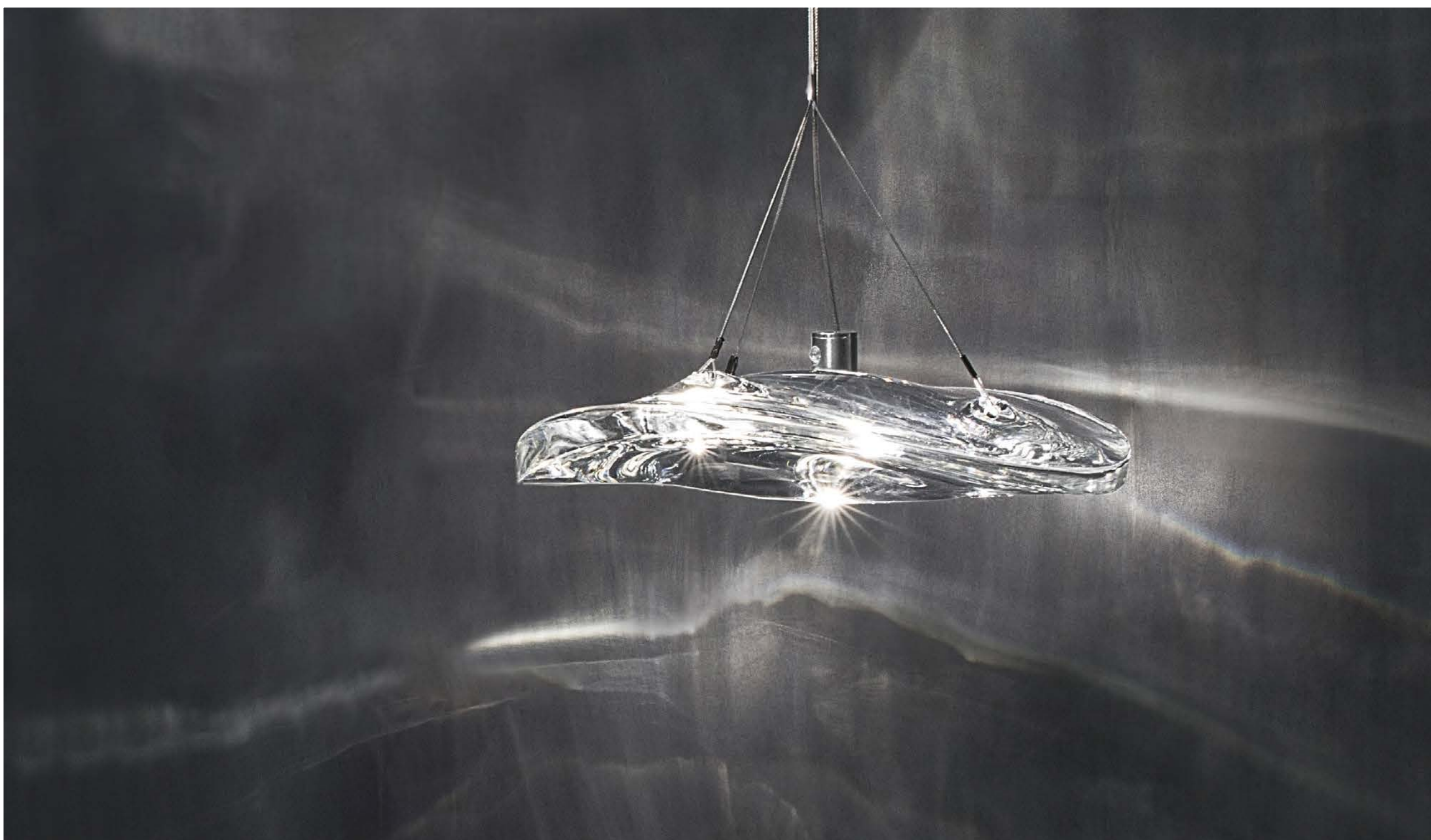





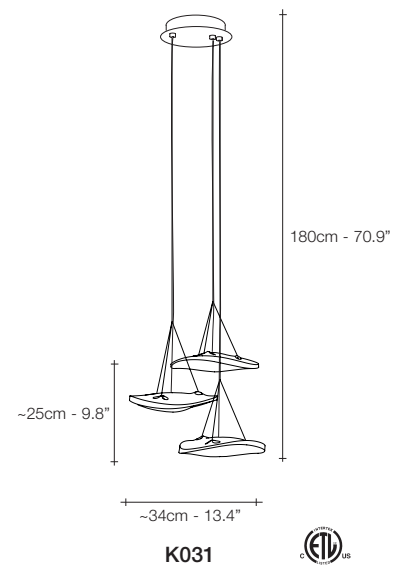
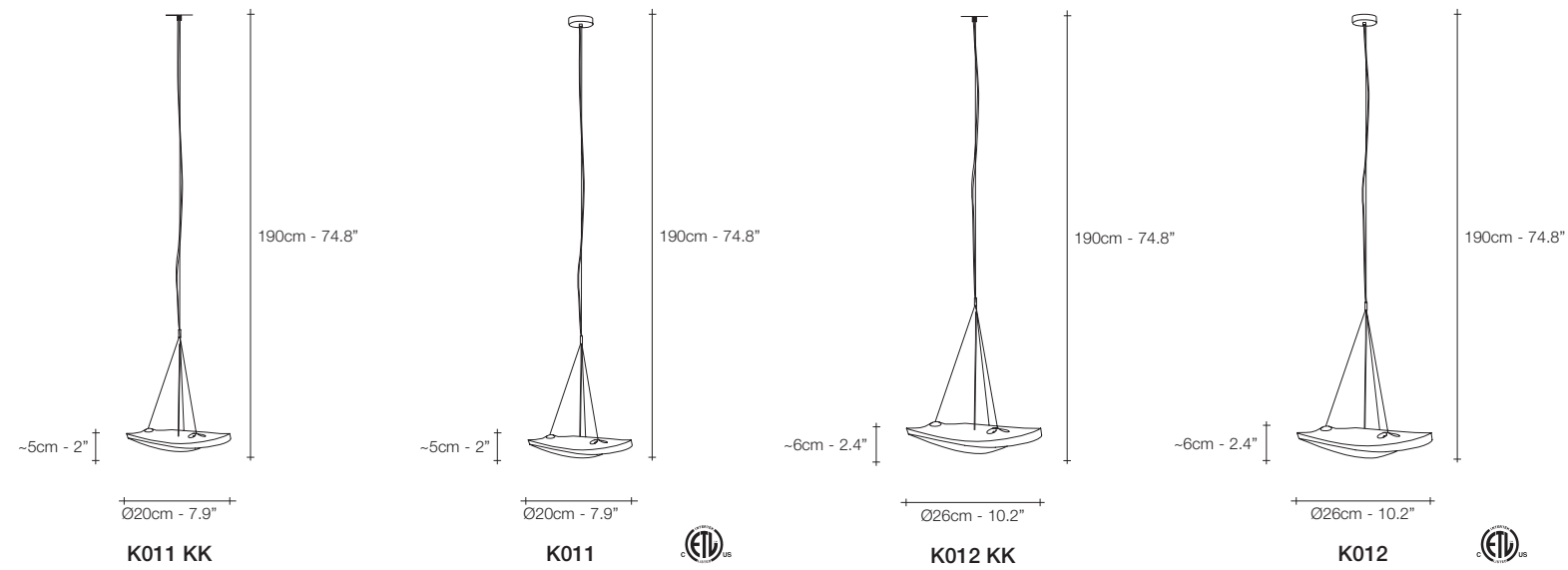

CLEAR CRYSTAL

	K011 KK	K011	K012 KK	K012	K031
230V	Replaceable LED module				
	1,5W	1,5W	1,5W	1,5W	3x1,5W
	3000K	135lm	135lm	135lm	405lm
	2700K	115lm	115lm	115lm	345lm
Dimmable	0/1-10V PUSH/DALI	PUSH/DALI	1-10V PUSH/DALI	PUSH/DALI	1-10V PUSH/DALI
120V	Replaceable LED module				
	1,5W	1,5W	1,5W	1,5W	3x1,5W
	3000K	135lm	135lm	135lm	405lm
	2700K	115lm	115lm	115lm	345lm
Dimmable	0/1-10V PUSH/DALI	no	0/1-10V PUSH/DALI	no	1-10V PUSH

Manta can be manufactured to work with integrated LED 3000K or 2700K. Different dimming options on request. Only 3000K version has the ETL certification.



Gaia, earth *mother.*

In Greek mythology, Gaia is the personification of the Earth and the mother of all life. Looking to capture the mythical and natural beauty of this Earth goddess, designer Jean-François Crochet has created the Gaia pendant light. Consisting of geometric frames of brass or raw metal reminiscent of the mountains Gaia created, the pendant uses led light to push light through the “cracks” formed. The resulting light creates a magical feeling, as if the lights peaking through were alive themselves. Also available in gold plated, nichel and wood finish and in custom configurations, Gaia adds a vibrancy and sacred light to any space. Design Jean-François Crochet. Made in Italy.













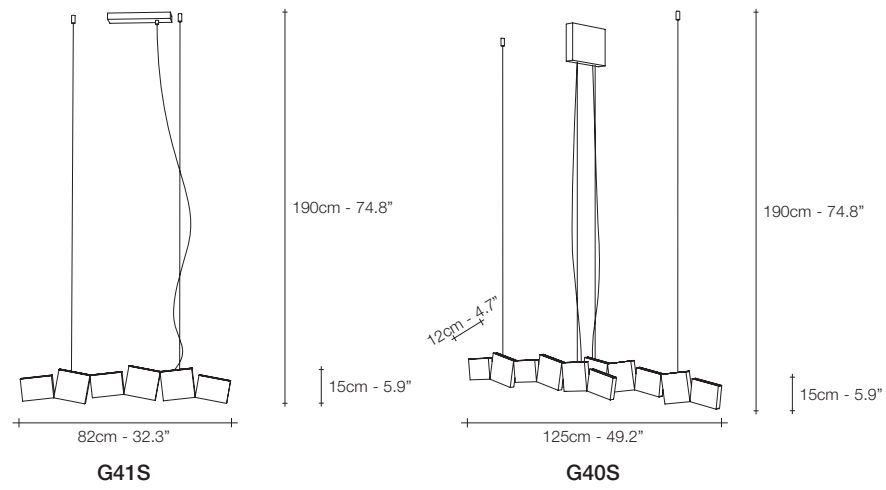

RAW METAL

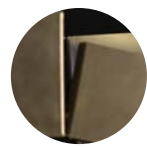

RAW BRASS



NICKEL



GOLD PLATED

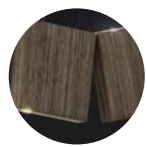

MATT WOOD | RAW BRASS

		G41S		G40S	
230V	○	Replaceable LED module	12x1,5W	24x1,5W	
		3000K	1752lm	3504lm	
		2700K	1548lm	3096lm	
		Dimmable	1-10V PUSH/DALI	0/1-10V PUSH/DALI	
120V	○	Replaceable LED module	12x1.5W	24x1.5W	
		3000K	1752lm	3504lm	
		2700K	1548lm	3096lm	
		Dimmable	1-10V PUSH	0/1-10V PUSH/DALI	

Gaia can be manufactured to work with integrated LED 3000K or 2700K. Different dimming options on request



Pug, multum *in parvo.*

Pug is a dog described as “much in little”, referring to the greatness of his personalities despite his diminutive size. Inspired by the Pug’s charm, designer Jean-François Crochet created the Pug pendant light whose protruding spherical lights are reminiscent of a pug’s face. As with the breed, the Pug pendant packs significant charm and beauty into a small package. Illuminated by LED light, these glass pendants are framed by two brass bands. With Pug, it’s easy to bring a new best friend (or pack of friends) into a home. Available in clear/raw brass and satin white/polished brass. Design Jean-François Crochet. Made in Italy.





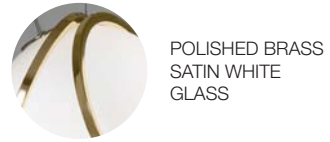
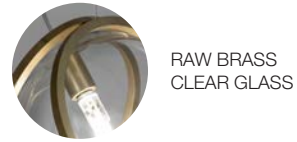
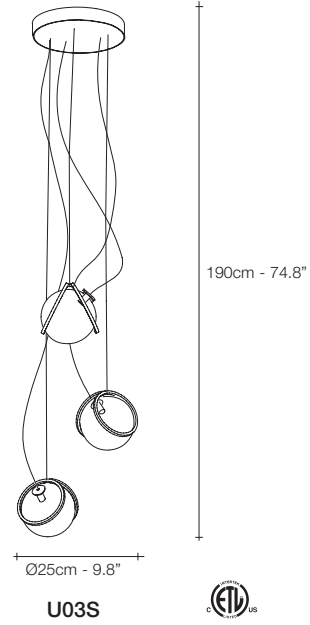
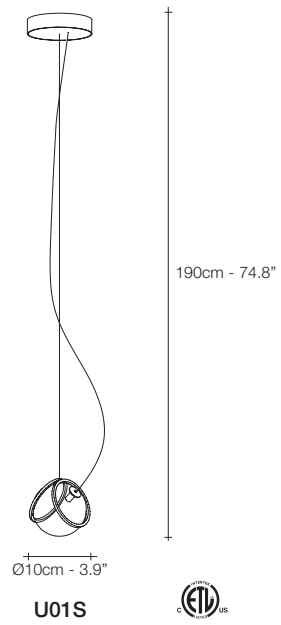
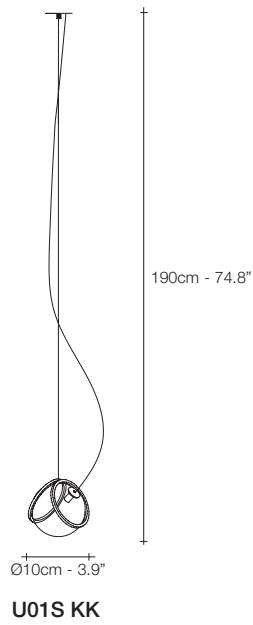

	LIGHT SOURCE	U01S KK	U01S	U03S
230V	G4 LED	1,5W	1,5W 3W	3x1,5W
	Dimmable	IGBT 10-100kΩ 0/1-10V PUSH/DALI	DALI	IGBT DALI
120V	G4 LED	1.5W	1.5W	3x1.5W
	Dimmable	ELV	no	ELV

Different dimming options on request



Abacus, multiplying *luminescence.*

Used for centuries as the tool to both teach and communicate mathematics, the abacus was found in one form or another across the ancient world. At Terzani, we saw the beauty in the abacus' mathematical purity and clean, functional design. In the hands of Terzani's craftsmen, we've turned this inspiration into a new collection of modular pendant lamps whose flexibility allows for complex and beautiful configurations. Each module, or strand, of Abacus contains a custom set of round, hand-blown opal glass which emit a soft and uniform light. And, as the original abacus was used to calculate everything from simple addition to complex formulas, we've retained the same scalability. Due to its customization, our Abacus light is just as suitable in a home as a commercial space, and its almost infinite configurations makes sure you always come up with the right solution. Design Draw. Made in Italy.









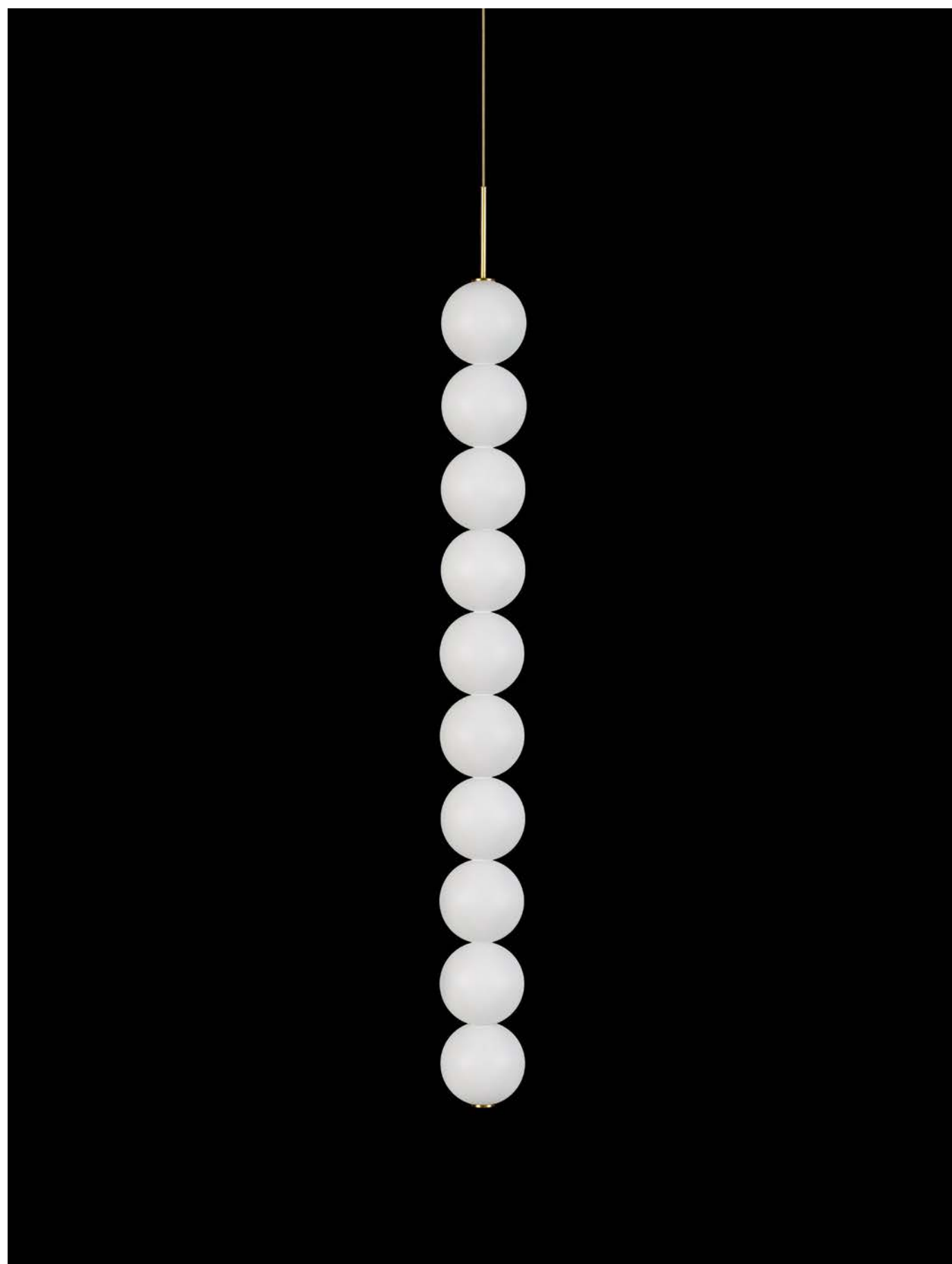

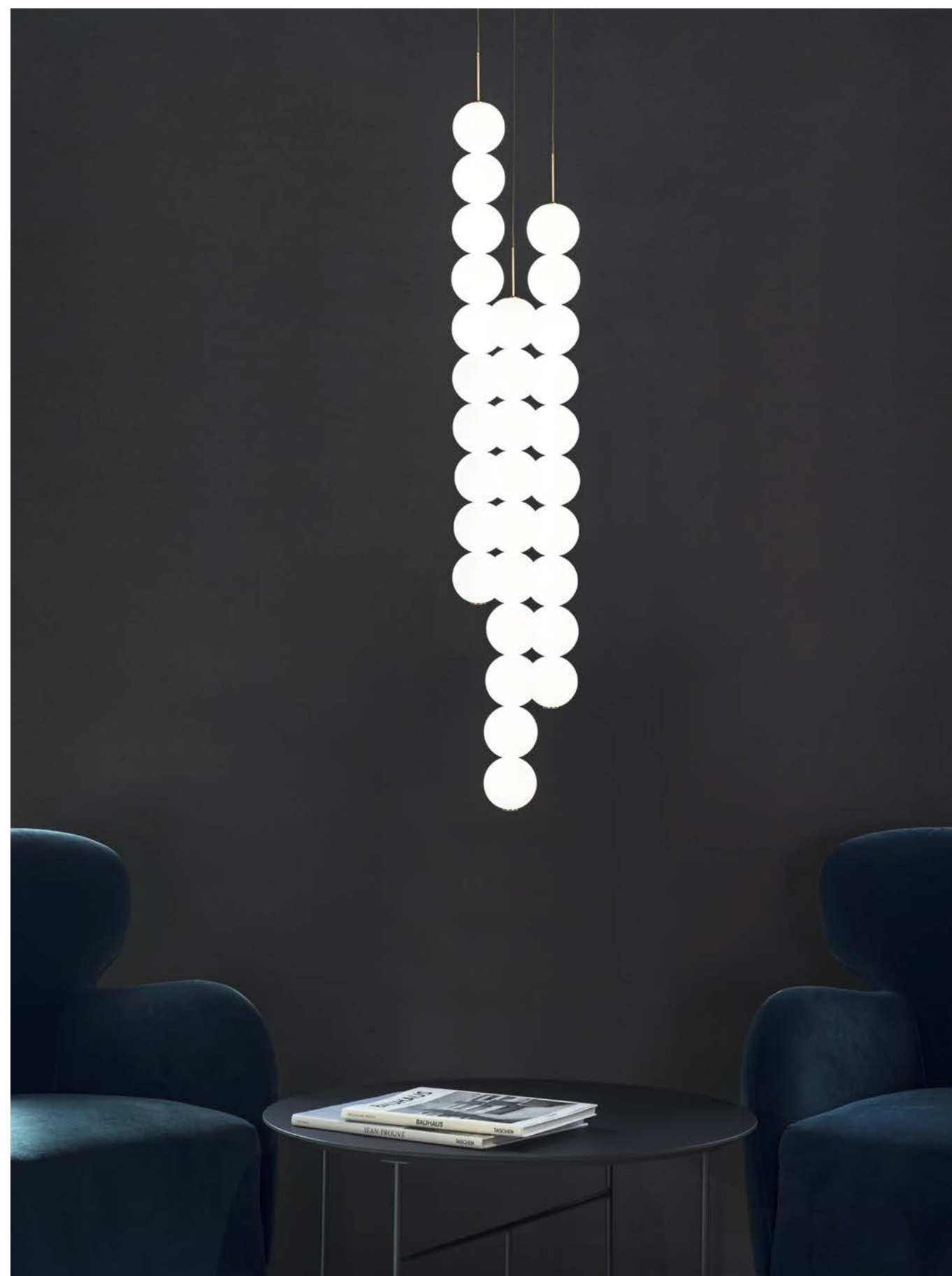
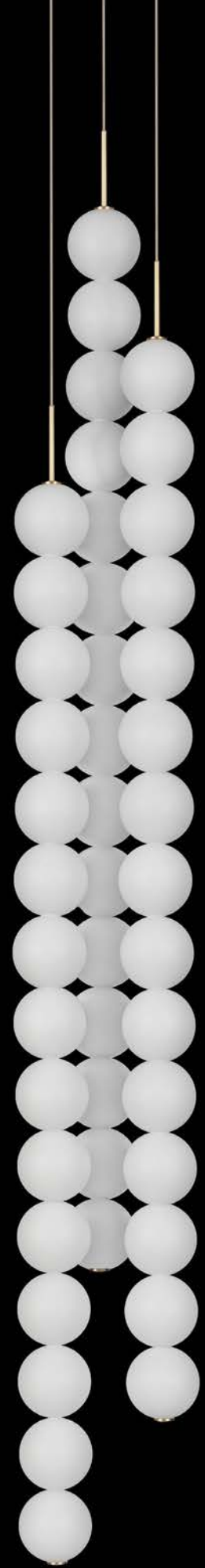

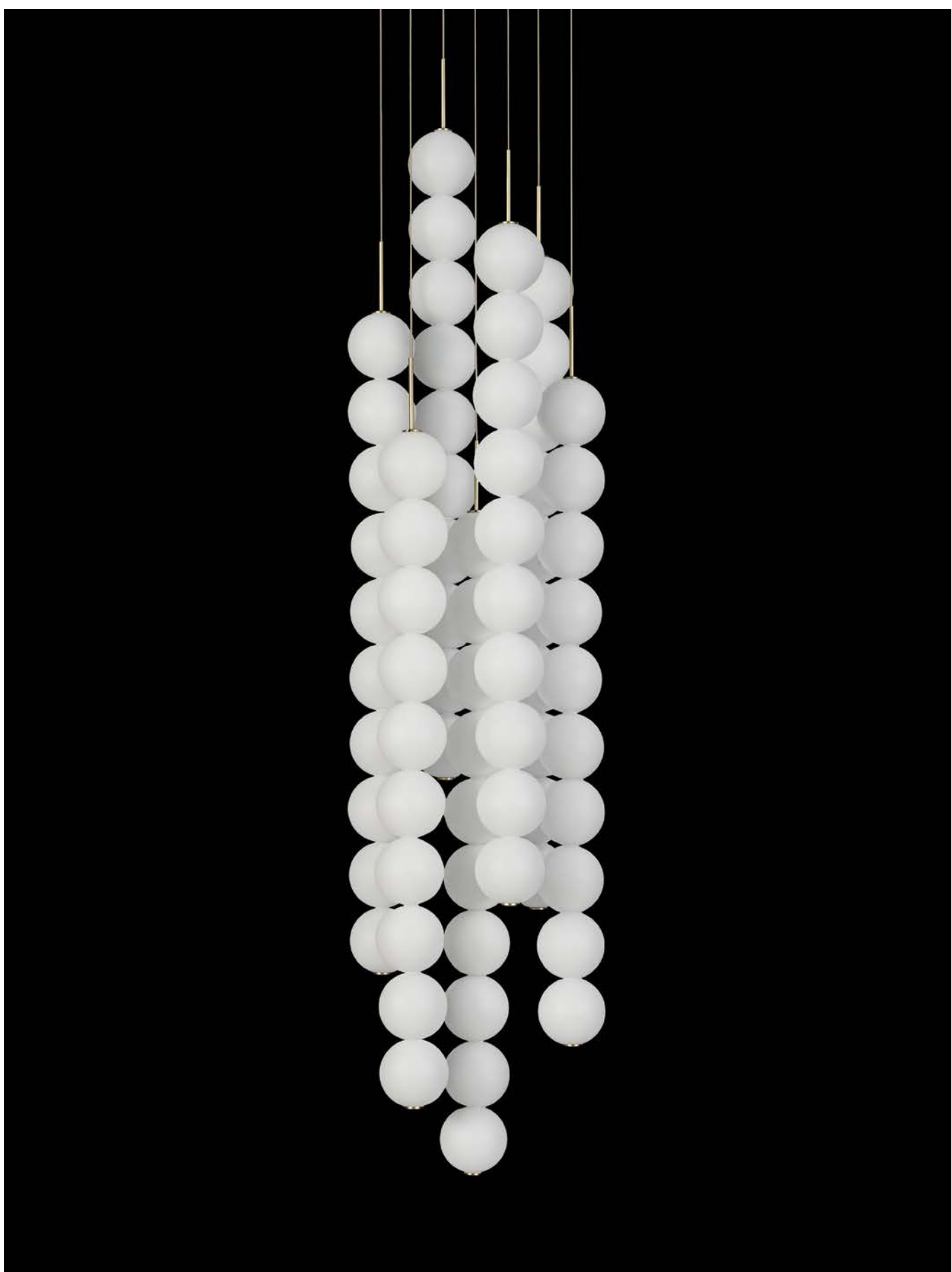

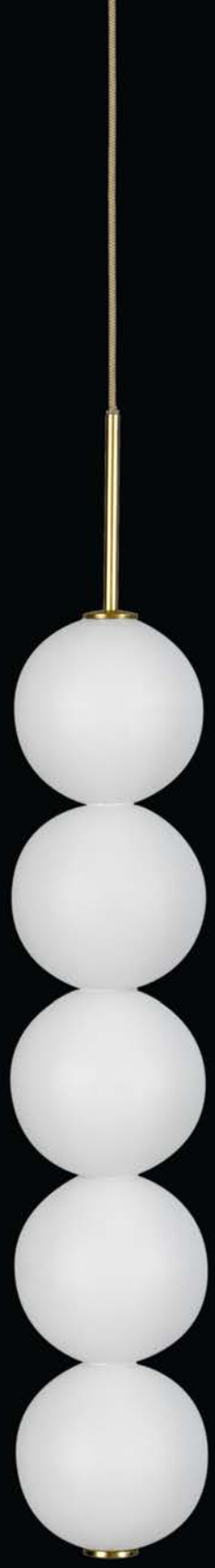



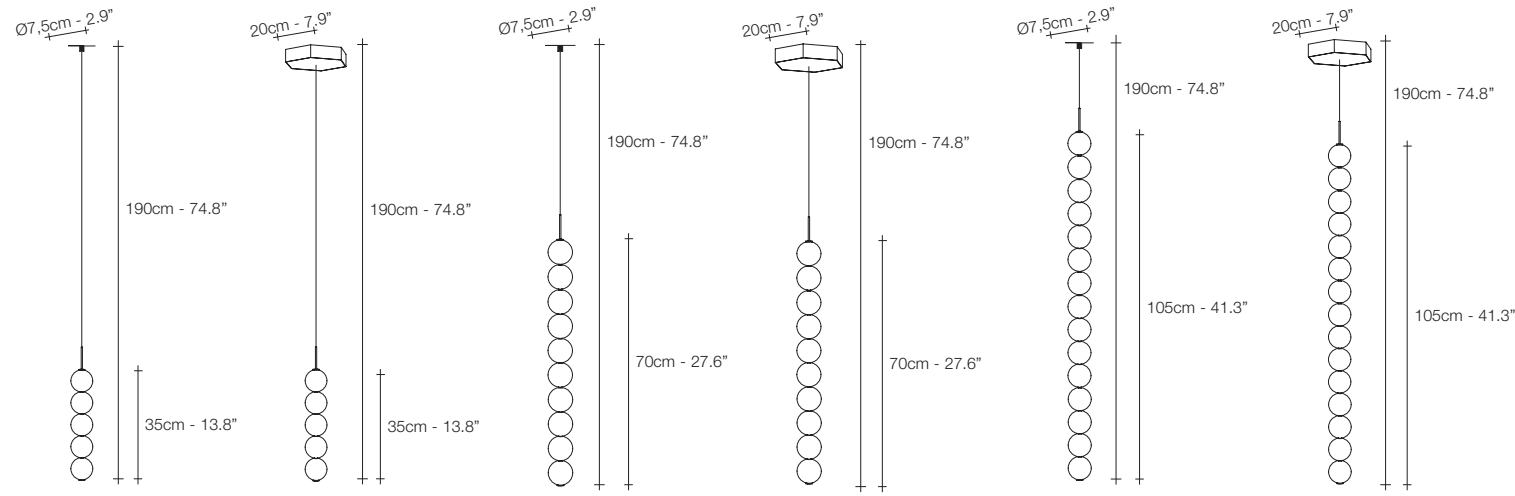

V01S 15KK 5 spheres
V01S P15 5 spheres
V01S 1AKK 10 spheres
V01S P1A 10 spheres
V01S 1FKK 15 spheres
V01S P1F 15 spheres

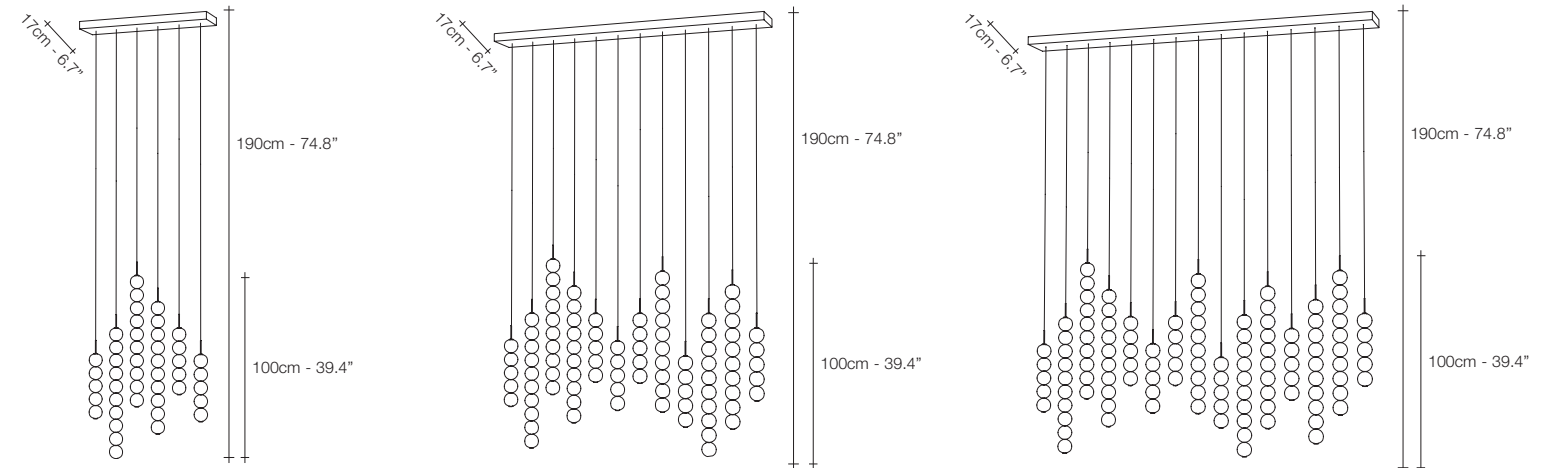

V06S R2B 3x5 - 3x10 spheres
V12S R3M 6x5 - 6x10 spheres
V15S R4D 7x5 - 8x10 spheres

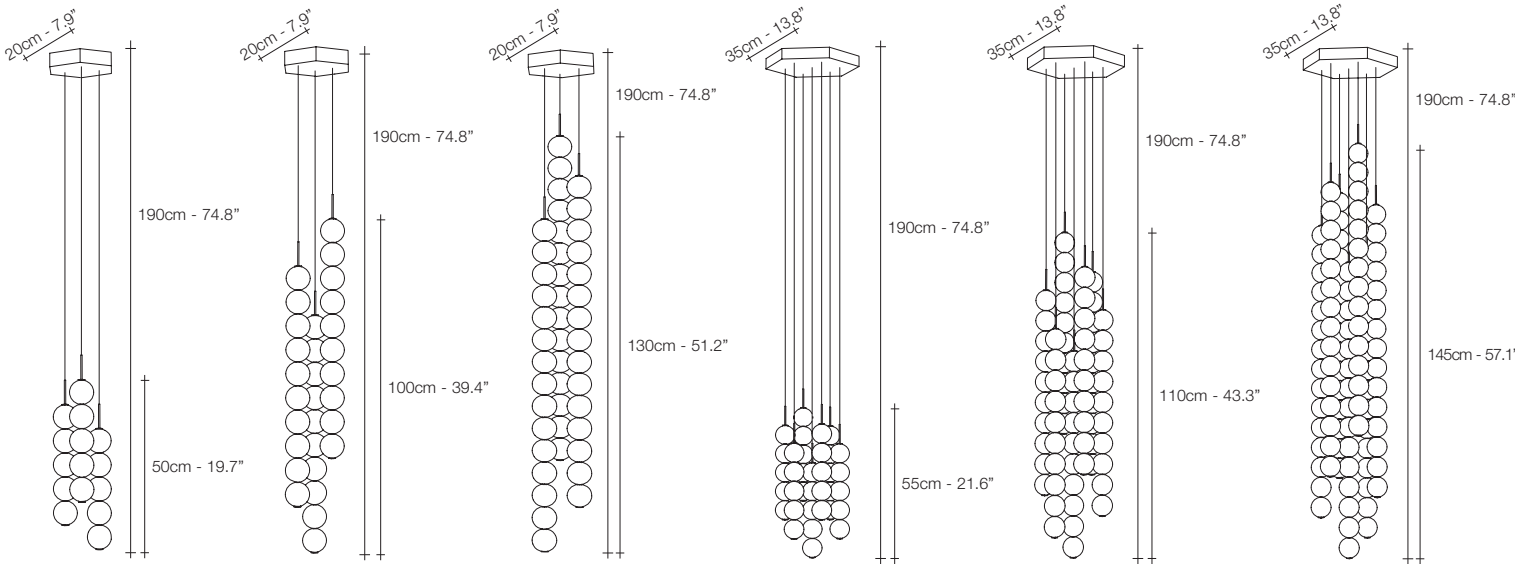

V03S P1F 3x5 spheres
V03S P1V 3x10 spheres
V03S P2B 3x15 spheres
V07S P21 7x5 spheres
V07S P32 7x10 spheres
V07S P43 7x15 spheres

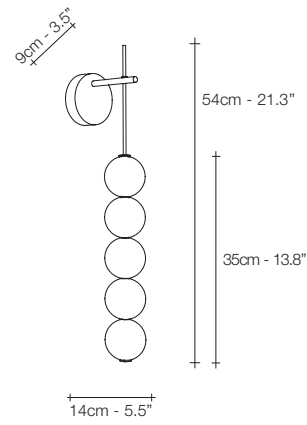

V01A 15
 5 spheres
 N/A in North America



BRASS
SATIN WHITE
GLASS

	LIGHT SOURCE	V01S 15KK	V01S P15	V01S 1AKK	V01S P1A	V01S 1FKK	V01S P1F	V03S P1F	V03S P1V	V03S P2B	V07S P21	V07S P32	V07S P43
230V	Replaceable LED module 3000K	3,6W 540lm	3,6W 540lm	7,2W 1080lm	7,2W 1080lm	10,8W 1620lm	10,8W 1620lm	3 x 3,6W 1620lm	3 x 7,2W 3240lm	3x10,8W 4860lm	7 x 3,6W 3780lm	7 x 7,2W 7560lm	7 x 10,8W 11340lm
	Dimmable	0/1-10V PWM 10-100kΩ PUSH/DALI	0/1-10V PWM 10-100kΩ PUSH/DALI	0/1-10V PWM 10-100kΩ PUSH/DALI	0/1-10V PWM 10-100kΩ PUSH/DALI	0/1-10V PWM 10-100kΩ PUSH/DALI	0/1-10V PWM 10-100kΩ PUSH/DALI	0/1-10V PWM 10-100kΩ PUSH/DALI	0/1-10V PWM 10-100kΩ PUSH/DALI	0/1-10V PWM 10-100kΩ PUSH/DALI	0/1-10V PWM 10-100kΩ PUSH/DALI	0/1-10V PWM 10-100kΩ PUSH/DALI	0/1-10V PWM 10-100kΩ PUSH/DALI
120V	Replaceable LED module 3000K	3,6W 540lm	3,6W 540lm	7,2W 1080lm	7,2W 1080lm	10,8W 1620lm	10,8W 1620lm	3 x 3,6W 1620lm	3 x 7,2W 3240lm	3 x 10,8W 4860lm	7 x 3,6W 3780lm	7 x 7,2W 7560lm	7 x 10,8W 11340lm
	Dimmable	0-10V PWM	0-10V PWM	0-10V PWM	0-10V PWM	0-10V PWM	0-10V PWM	0-10V PWM	0-10V PWM	0-10V PWM	0-10V PWM	0-10V PWM	0-10V PWM

Different dimming options on request

	LIGHT SOURCE	V06S R2B	V12S R3M	V15S R4D	V01A 15
230V	Replaceable LED module 3000K	3 x 3,6W 3 x 7,2W 4860lm	6 x 3,6W 6 x 7,2W 9720lm	7 x 3,6W 8 x 7,2W 12420lm	3,6W 540lm
	Dimmable	0/1-10V PWM 10-100kΩ PUSH/DALI	0/1-10V PWM 10-100kΩ PUSH/DALI	0/1-10V PWM 10-100kΩ PUSH/DALI	0/1-10V PUSH
120V	Replaceable LED module 3000K	3 x 3,6W 3 x 7,2W 4860lm	6 x 3,6W 6 x 7,2W 9720lm	7 x 3,6W 8 x 7,2W 12420lm	-
	Dimmable	0-10V PWM	0-10V PWM	0-10V PWM	-

Different dimming options on request

Oscar, *a tribute.*

The great Brazilian architect Oscar Niemeyer once said about his work: "It's not the right angle that attracts me, nor the straight line. Stiff, inflexible, created by men. What really attracts me is the free, sensual curve. The curve I see on the sinuous course of our rivers, on the clouds in the sky, on your favorite woman's body. The universe is entirely made of curves". Inspired to pay tribute to one of the founders of modern architecture, designer Dodo Arslan has created a series of lights named "Oscar", which pay homage through their adoption of Niemeyer's signature sensuous curves. Oscar table lamp consists of a glass orb delicately held by curved brass. Available in nickel, brass, black, white, gold plated and rose gold finish. Design Dodo Arslan. Made in Italy.

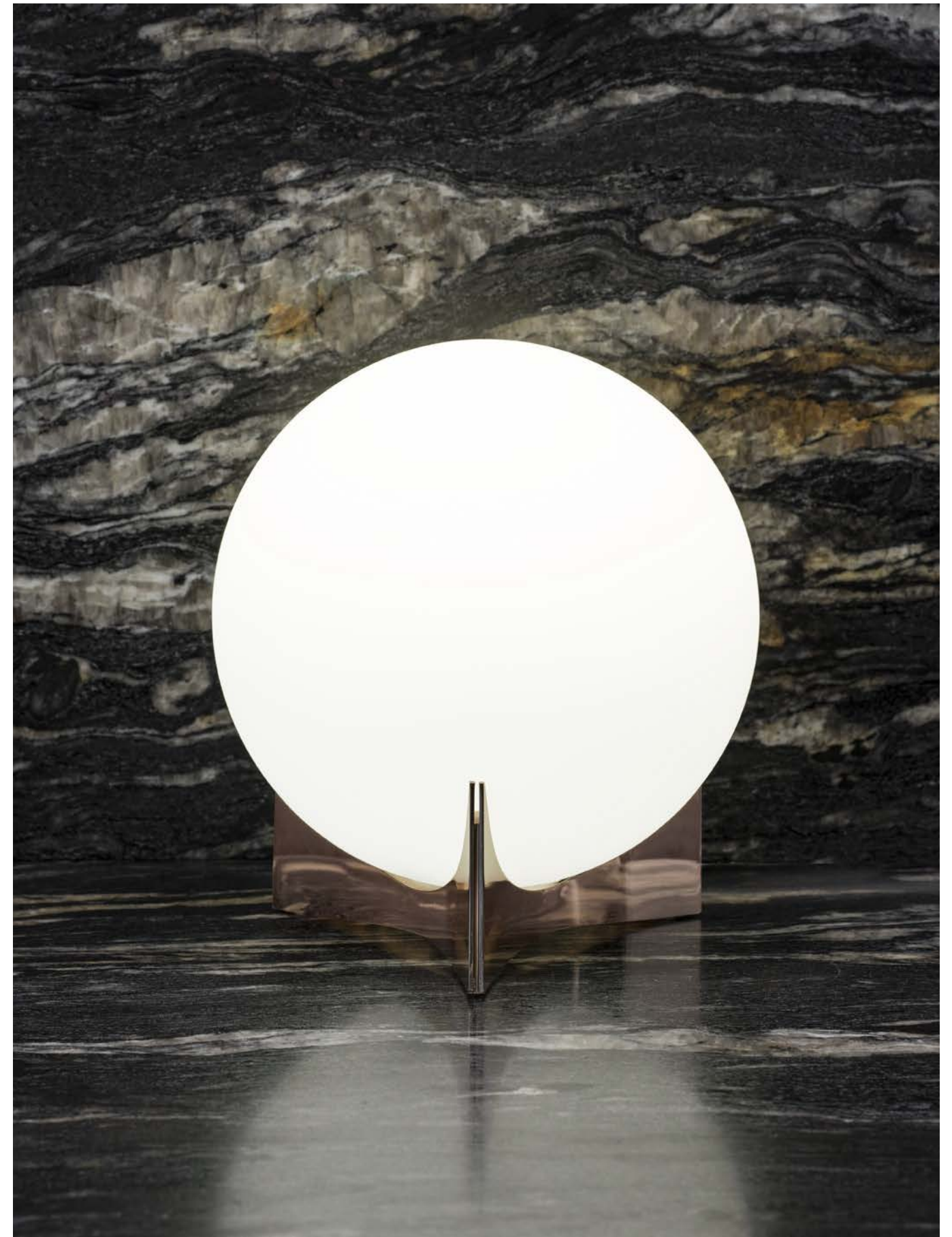



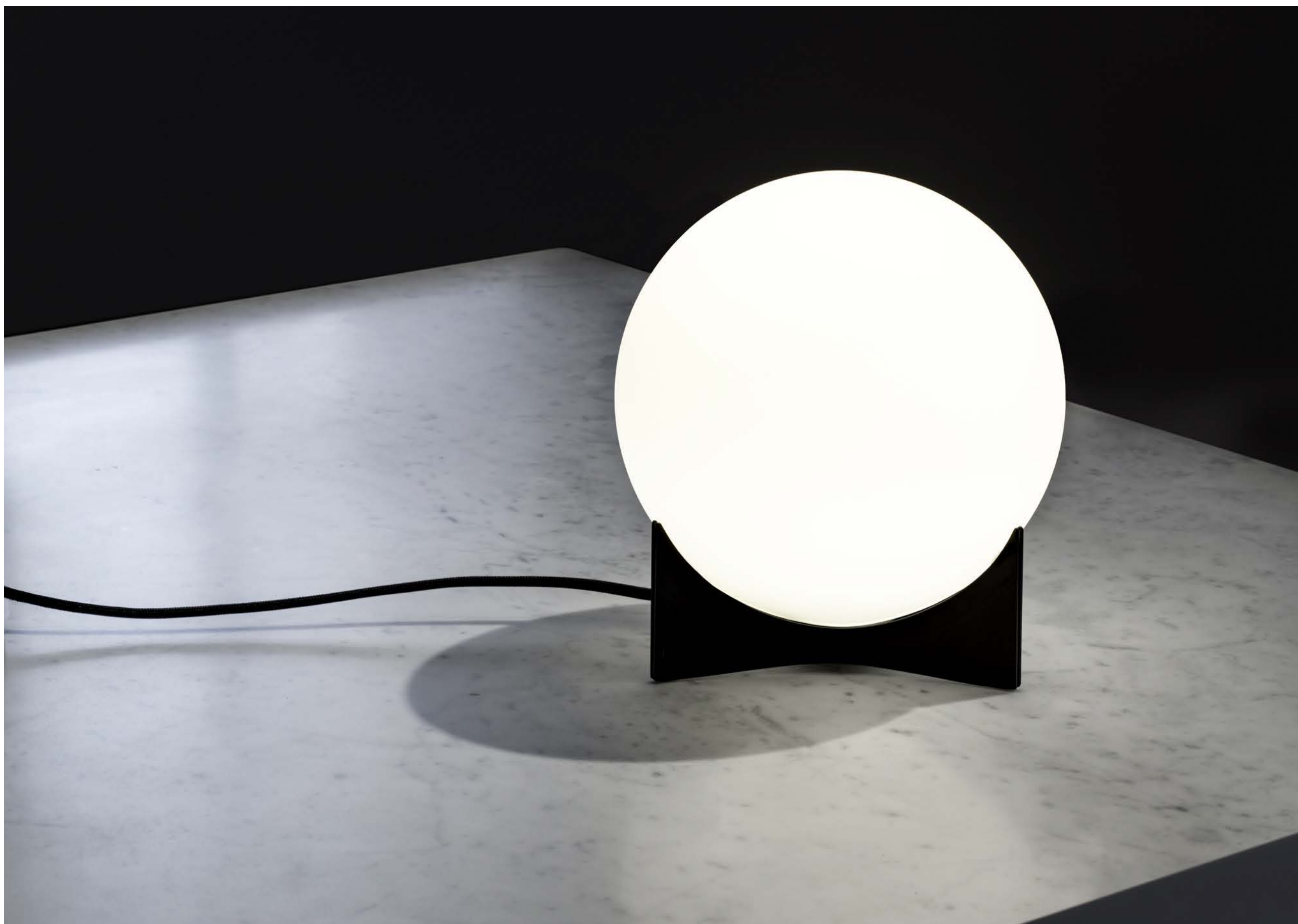



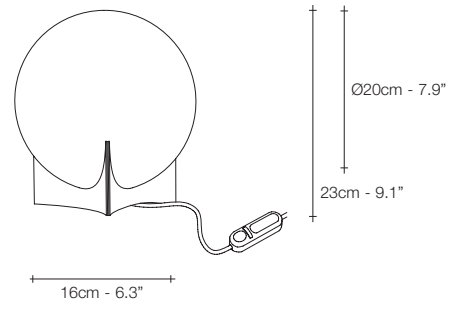

C02B

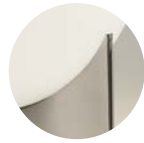

NICKEL
SATIN WHITE
GLASS



BRASS
SATIN WHITE
GLASS

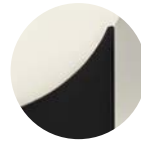

BLACK
SATIN WHITE
GLASS

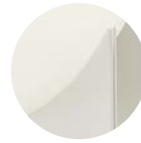



WHITE
SATIN WHITE
GLASS



GOLD PLATED
SATIN WHITE
GLASS



ROSE GOLD PLATED
SATIN WHITE
GLASS

LIGHT SOURCE		C02B
230V	 E14 LED	7W
	Dimmable	✓
120V	 E12 LED	7W
	Dimmable	✓



Moiré, movement *with pattern.*

A French term derived from silk with a rippled or “watered” appearance, moiré is an optical effect that results in the illusion of waves or the movement of water. This effect is achieved by having an opaque, ruled pattern overlaid over another. Designer Christian Lava’s studies of this effect have led to his latest design aptly titled, Moiré. Using overlapping grids of metal, this LED pendant light dynamically changes shape following the viewer’s gaze, practically coming to life with a vibrating energy. Moiré is a mesmerizing addition to any room. Available in gold plated and nickel finish. Design Christian Lava. Made in Italy.









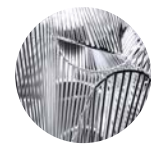
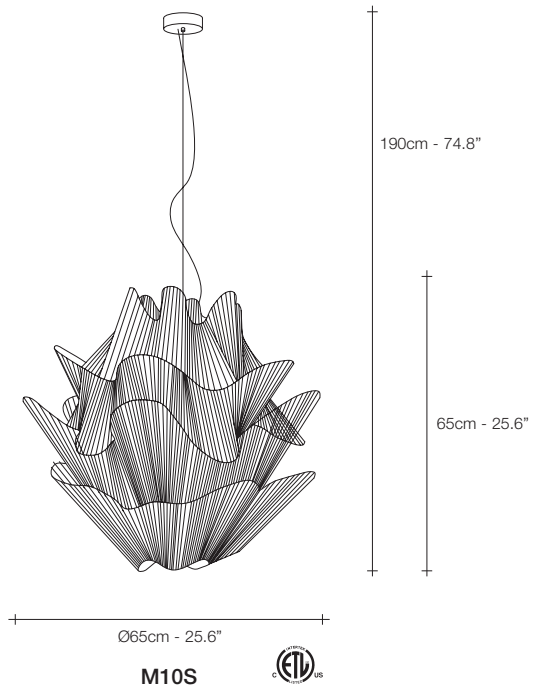

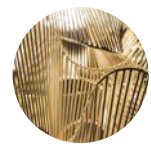

NICKEL



GOLD PLATED

LIGHT SOURCE		M10S	
230V	 Replaceable LED module 3000K	15W	1952lm
		Dimmable	1-10V PUSH/DALI
120V	 Replaceable LED module 3000K	15W	1952lm
		Dimmable	1-10V PUSH

Different dimming options on request

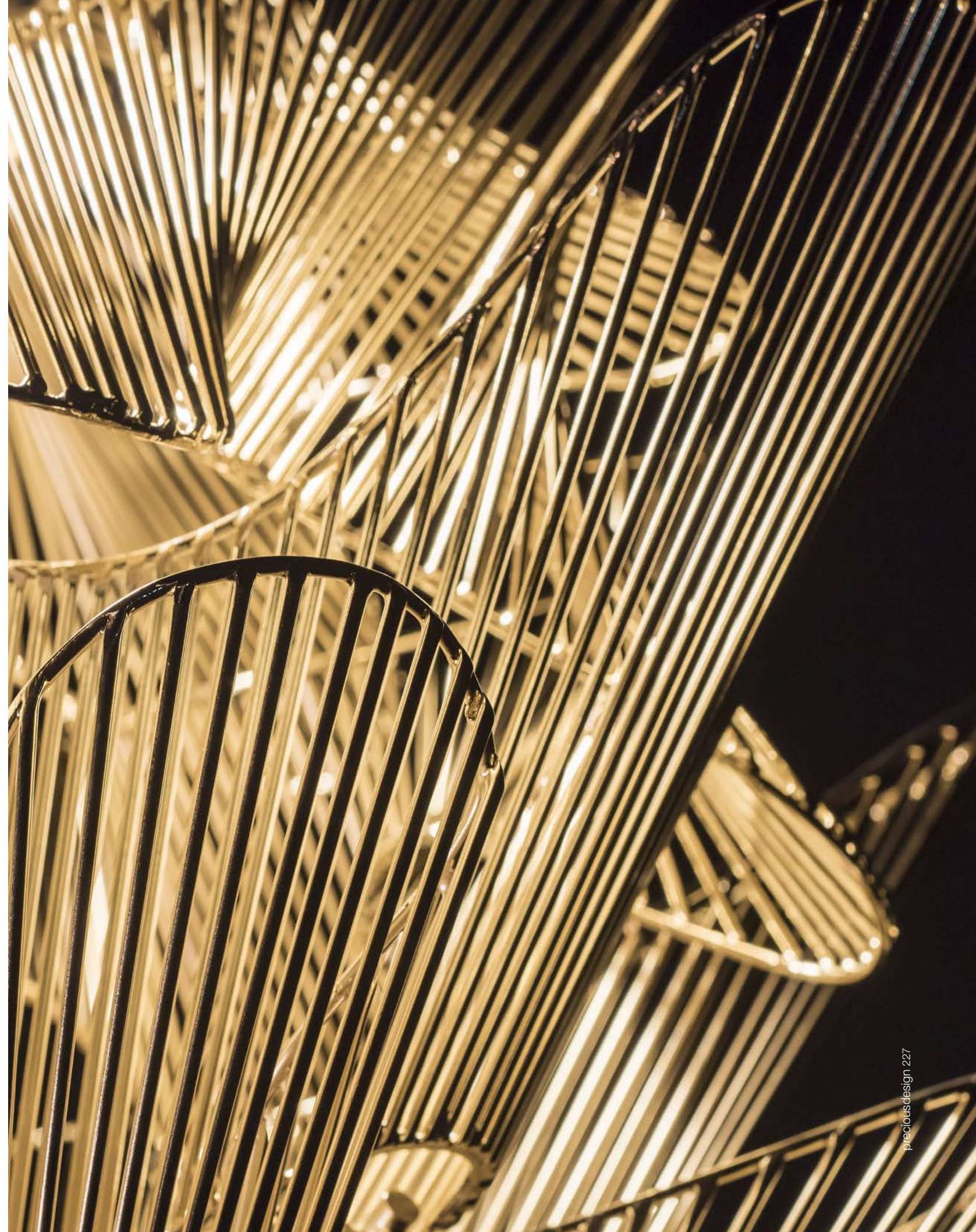

Doodle, Freehand *Design.*

We no longer march in a straight line. Our lives are dynamic, intertwining collections of relationships, experiences and journeys. Reflecting the fluidity of our generation, designer Simone Micheli has created a new, contemporary light for Terzani, Doodle. Like us, each Doodle is unique, each pendant is handcrafted by artisans to resemble a randomised path. And, to give us control over the journey we want to take, each LED bulb can be placed anywhere on the light, not only reflecting the choices we make in life, but giving Doodle a special flexibility. Available in nickel, black amethyst, gold and copper plated finishes. Design Simone Micheli. Made in Italy











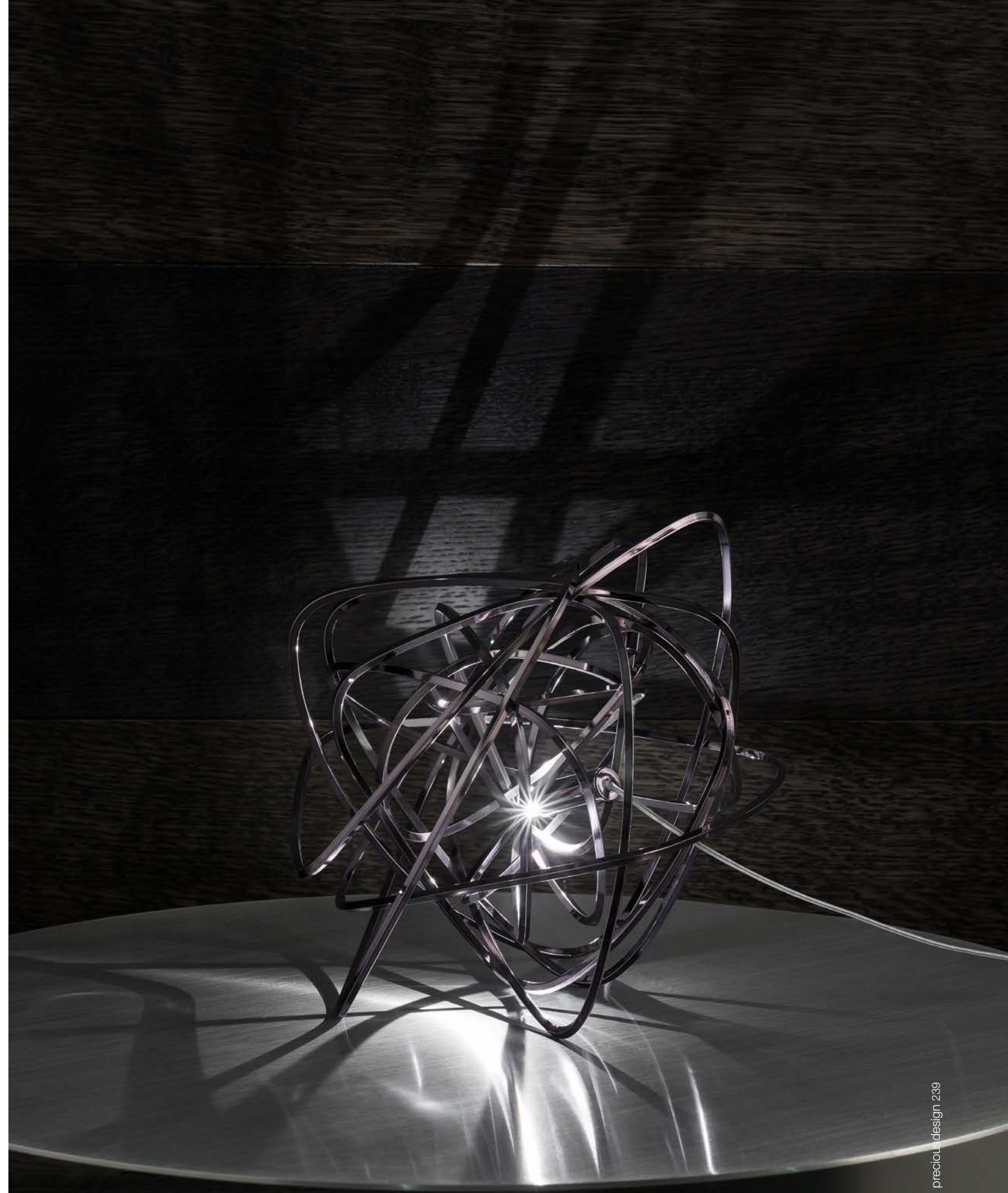





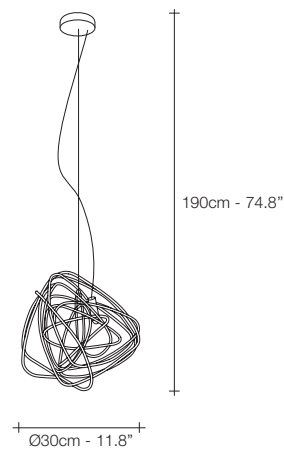

J80S

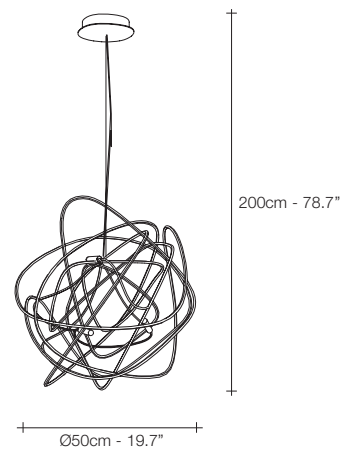

J93S

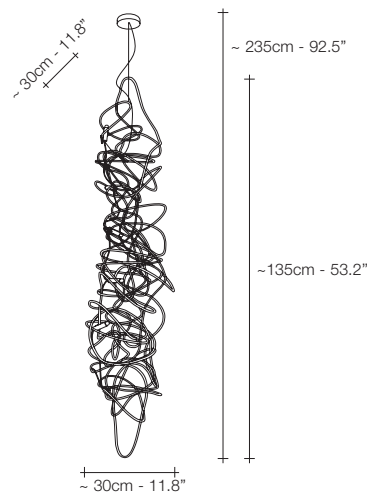

J87S

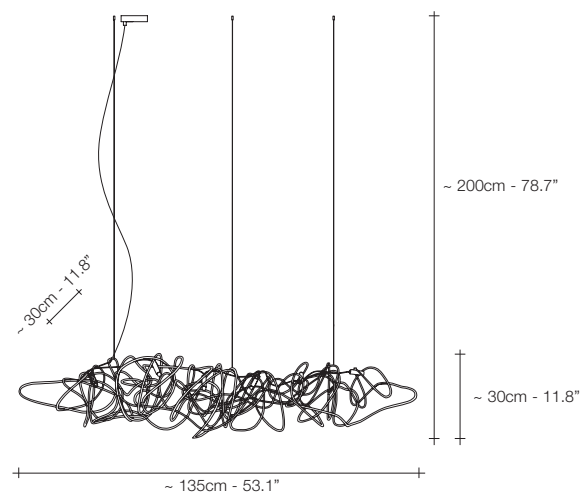

J81S

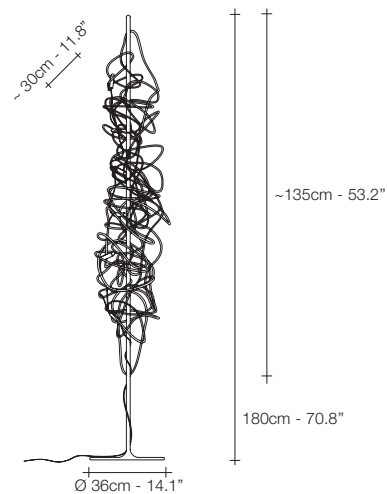

J86P

N/A in North America

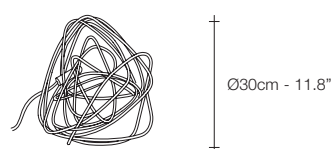

J84B

N/A in North America

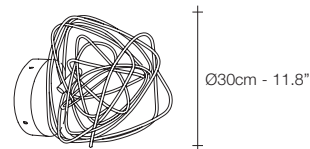

J82A



NICKEL



BLACK AMETHYST



GOLD PLATED

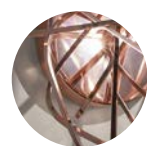

COPPER

	LIGHT SOURCE	J80S	J93S	J87S	J81S	J86P	J84B	J82A
230V	G4 LED	2W	5x2W 2W	6x2W 2W	6x2W 2W	6x1,2W 1,2W	2W	2W
	Dimmable	0/1-10V 10-100kΩ PUSH/DALI	IGBT DALI	IGBT DALI	IGBT DALI	no	no	0/1-10V 10-100kΩ PUSH/DALI
120V	G4 LED	2W	5x2W	6x2W	6x2W	-	-	2W
	Dimmable	no	ELV	ELV	ELV	-	-	ELV

Different dimming options on request

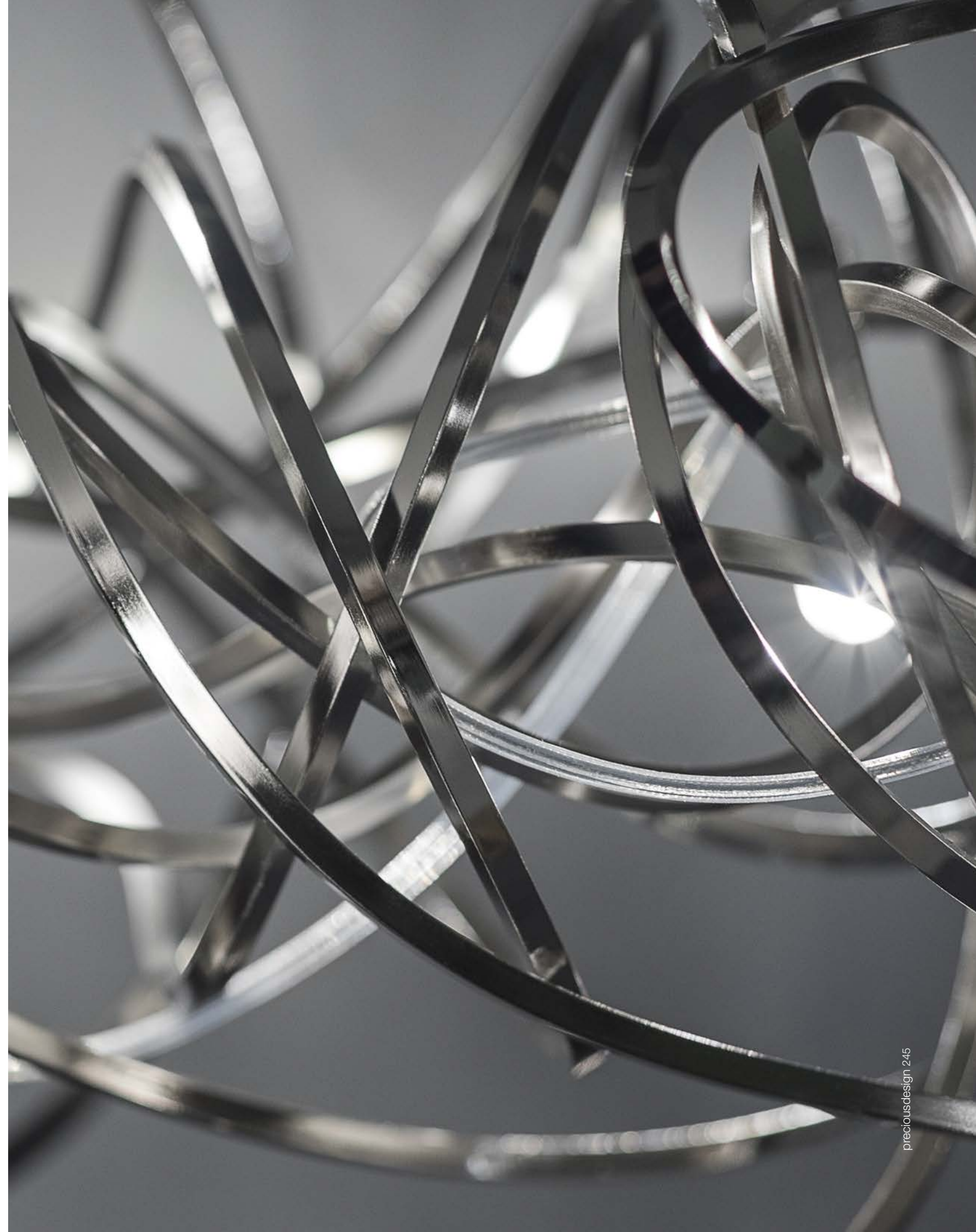

I Lucci Argentati, School of *Light.*

I Lucci Argentati draws from nature to create a whimsical, yet modern light. Recalling a school of fish darting through freshwater, it creates a mesmerizing luminescence. Sets of sleek lights combine to form a stunning pendant with thin incisions along the bottom creating an understated, tranquil beauty. Thanks to its modular system, I Lucci Argentati is customizable and can be combined in many different configurations: from small to extra large; as a pendant or sconce; and finished either in brushed nickel, brushed gold plated or white. Design Dodo Arslan. Made in Italy.















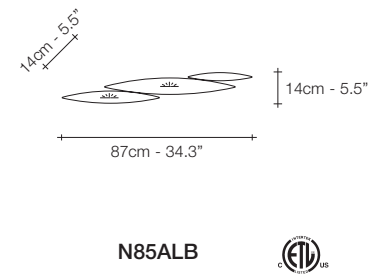
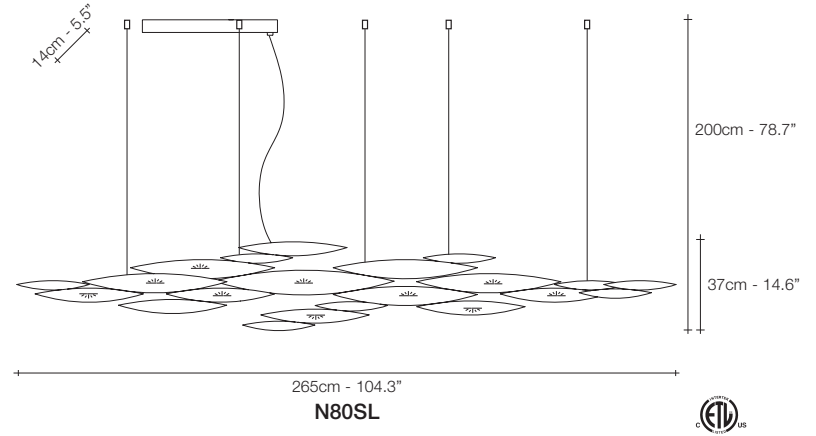
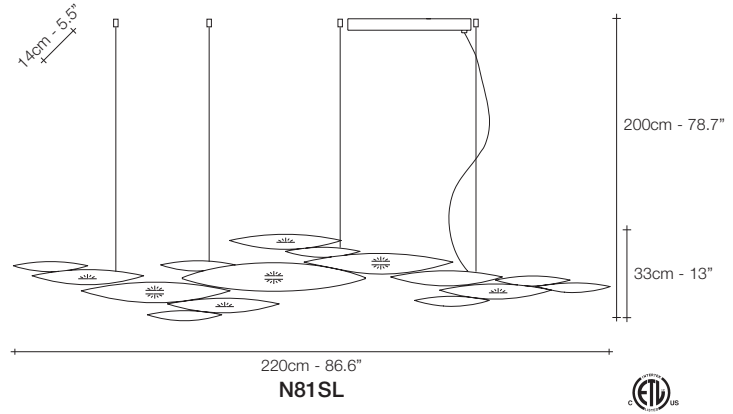
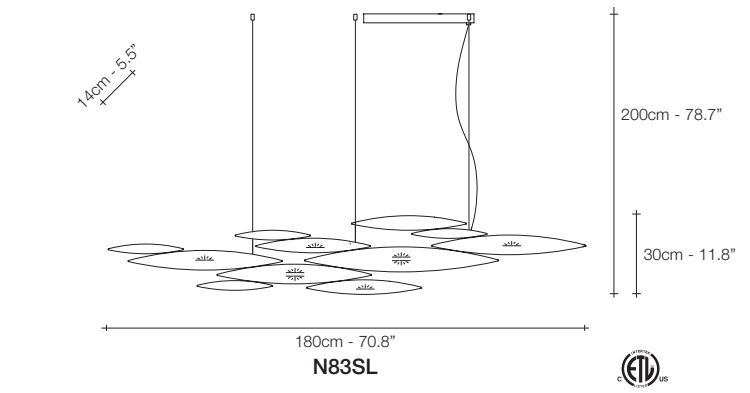
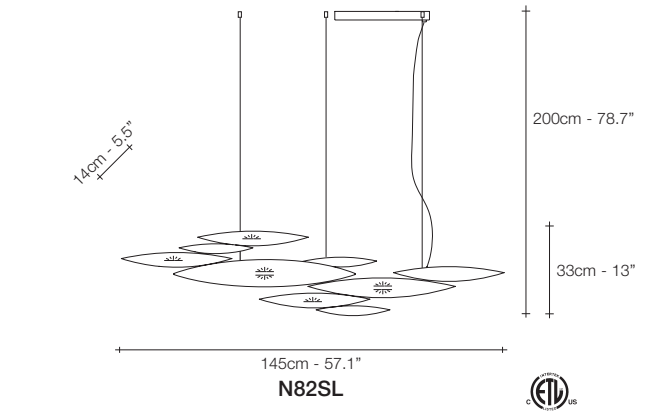

BRUSHED NICKEL



WHITE



BRUSHED GOLD PLATED

	LIGHT SOURCE	N82SL	N83SL	N81SL	N80SL	N85ALB
230V	Replaceable LED module	7x4,5W	8x4,5W	10x4,5W	10x4,5W	2x4,5W
	CRI 90 3000K	4632lm	5294lm	6617lm	6617lm	1323lm
	2700K	4200lm	4800lm	6000lm	6000lm	1200lm
	Dimmable	0-10V PWM PUSH/DALI	0-10V PWM PUSH/DALI	0-10V PWM PUSH/DALI	0-10V PWM PUSH/DALI	0/1-10V PUSH/DALI
120V	Replaceable LED module	7x4.5W	8x4.5W	10x4.5W	10x4.5W	2x4.5W
	CRI 90 3000K	4632lm	5294lm	6617lm	6617lm	1323lm
	2700K	4200lm	4800lm	6000lm	6000lm	1200lm
	Dimmable	1-10V PWM	1-10V PWM	1-10V PWM	1-10V PWM	no

I Lucci Argentati can be manufactured to work with integrated LED 3000K or 2700K. Different dimming options on request.



Core, Eruption *of Light.*

Core is reminiscent of the natural energy at the heart of our world. Like bright lava seeping through the earth's crust, vibrant spheres of faceted glass break through the iron surface of this pendant. Forcing light to pass through this metal structure results in a powerful, vibrant exchange of forces light and shadow erupt across the room, as the light pours through, as the light itself emits an organic radiance. Available in nickel, black nickel and gold plated finishes. Design Christian Lava. Made in Italy.









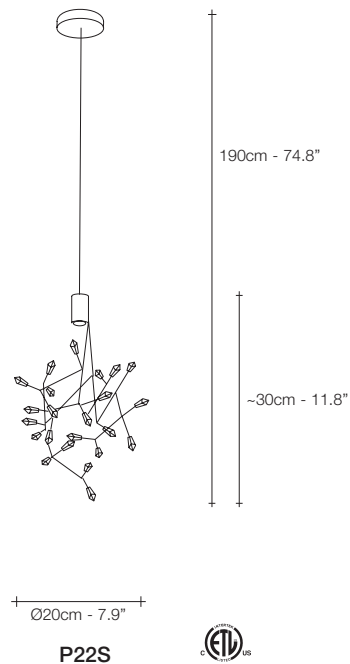

P22S

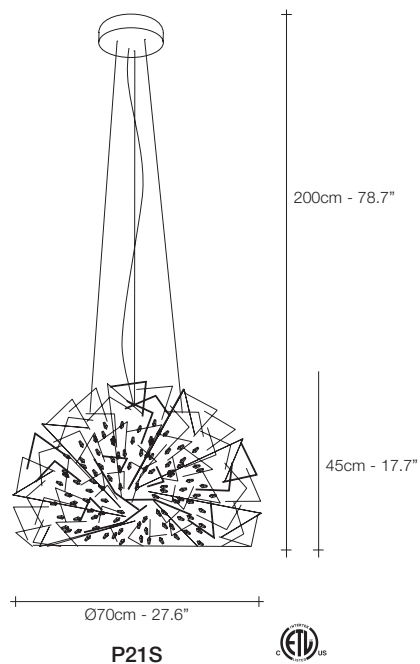

P21S

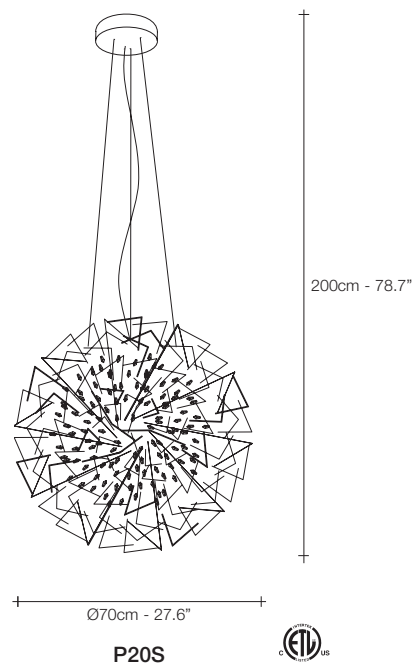

P20S



NICKEL
CLEAR GLASS



BLACK NICKEL
CLEAR GLASS



GOLD PLATED
CLEAR GLASS

VOLTAGE	P22S		P21S		P20S	
	LED SOURCE	WATTAGE	LED SOURCE	WATTAGE	LED SOURCE	WATTAGE
230V	Replaceable LED module 3000K 2700K	2.1W 194lm 172lm	Replaceable LED module CRI 90 3000K 2700K	18W 1640lm 1570lm	18W 1640lm 1570lm	
	Dimmable	no	Dimmable	1-10V PUSH/DALI	1-10V PUSH/DALI	
120V	Replaceable LED module 3000K 2700K	2.1W 194lm 172lm	Replaceable LED module CRI 90 3000K 2700K	18W 1640lm 1570lm	18W 1640lm 1570lm	
	Dimmable	no	Dimmable	1-10V PUSH	1-10V PUSH	

Core can be manufactured to work with 3000K or 2700K LED. Different dimming options on request



Iceberg, Pure *Light.*

Inspired by the natural beauty of ice crystals, this new suspension light creates a spectacular, luminous piece through the use of over 3600 plexyglass tubes. Similar to light refracting through water, the illumination created by Iceberg is both brilliant and natural, meticulously handcrafted, each light is a unique sculpture; sparkling, multifaceted and powerful. Design Dodo Arslan. Made in Italy.



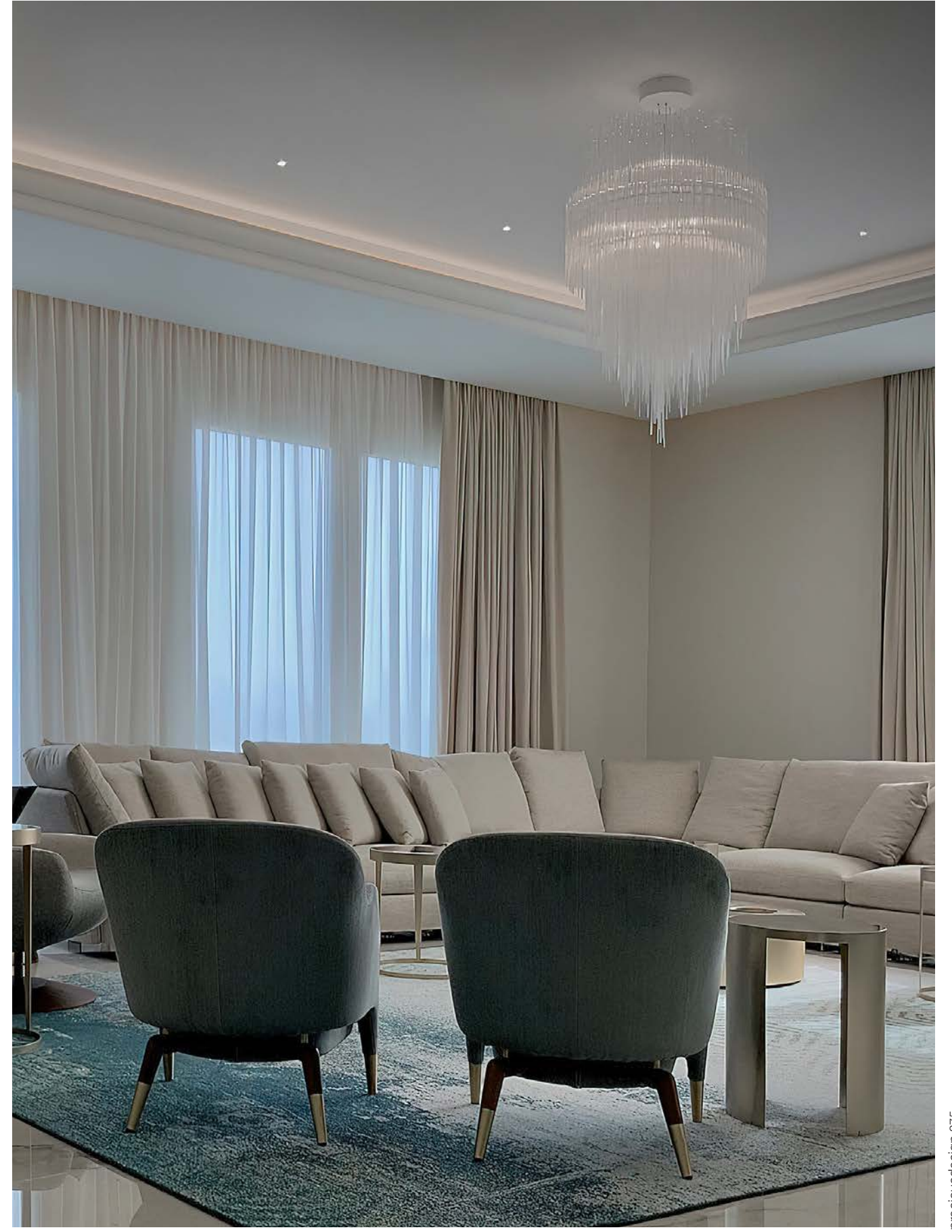

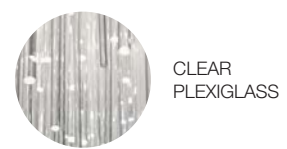
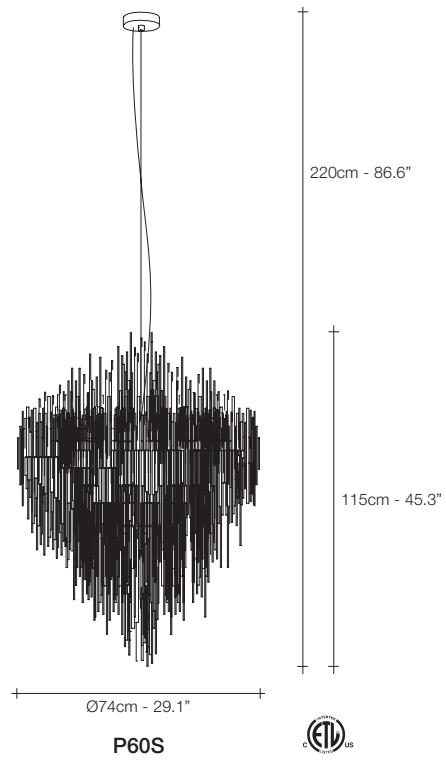

LIGHT SOURCE		P60S	
230V		E14 LED	6x6W
		E27 LED	8W
		Dimmable	✓
120V		E12 LED	6x5.5W
		E26 LED	8W
		Dimmable	✓



Frame, Nature's *Imprint.*

Capturing a moment in time, Frame features a metal coral leaf, enclosed inside a borosilicate glass preserving a delicate imprint of nature. Hidden inside is a single bulb which glows from within. Creating a stirring light that projects a dynamic shadow due to the permeable coral. Frame is available in white, gold plated or silver plated. Design Terzani Lab.





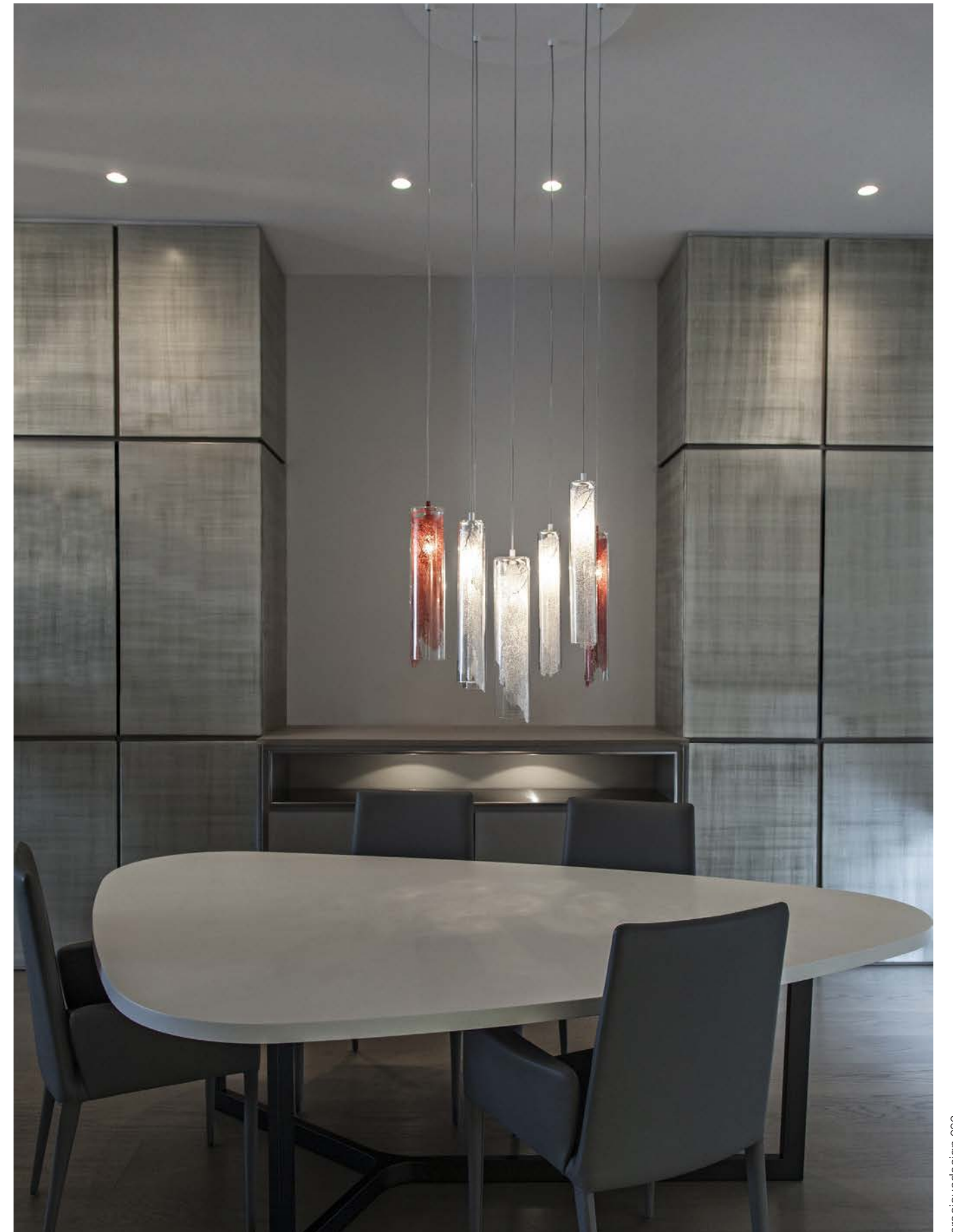

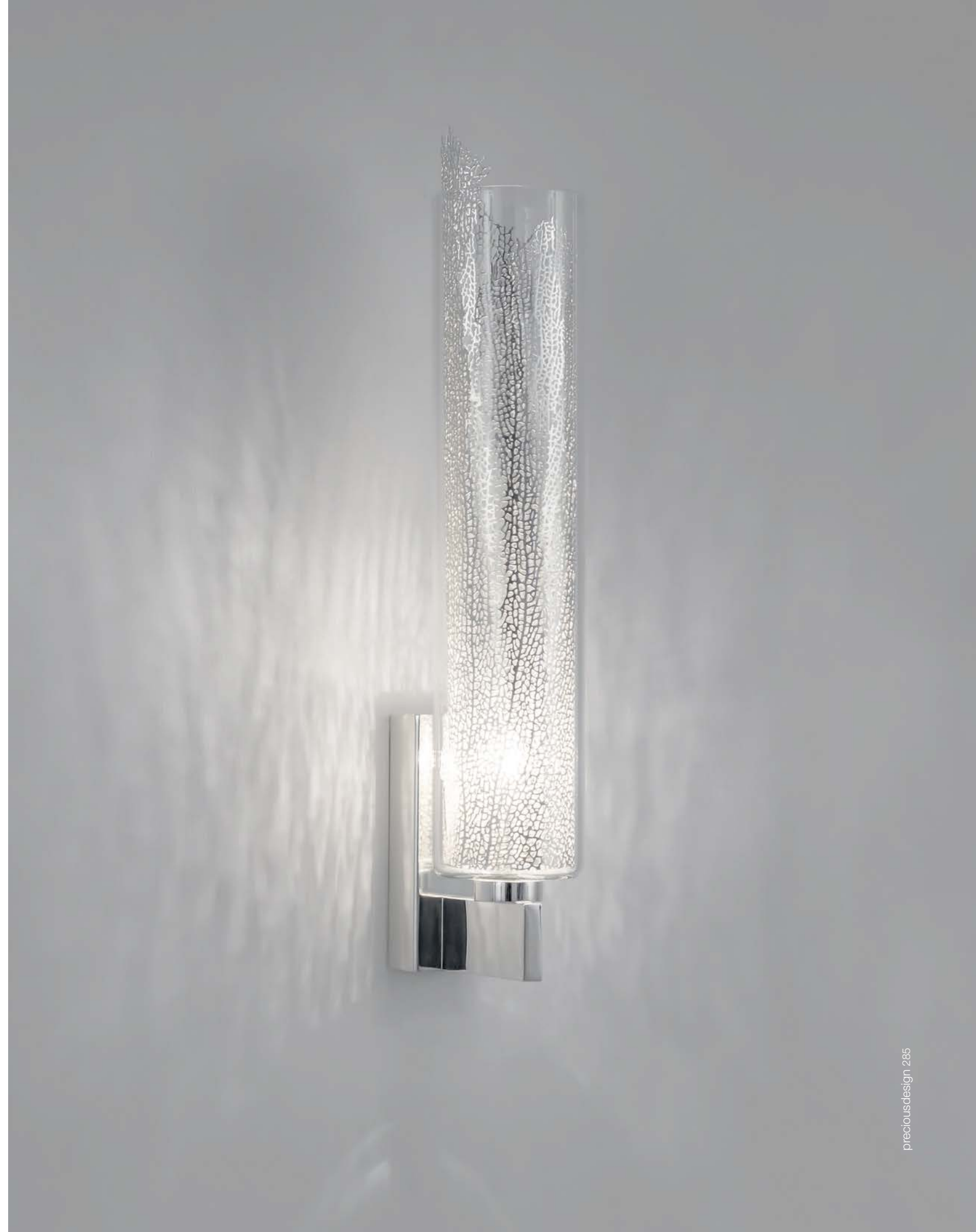



White and clear

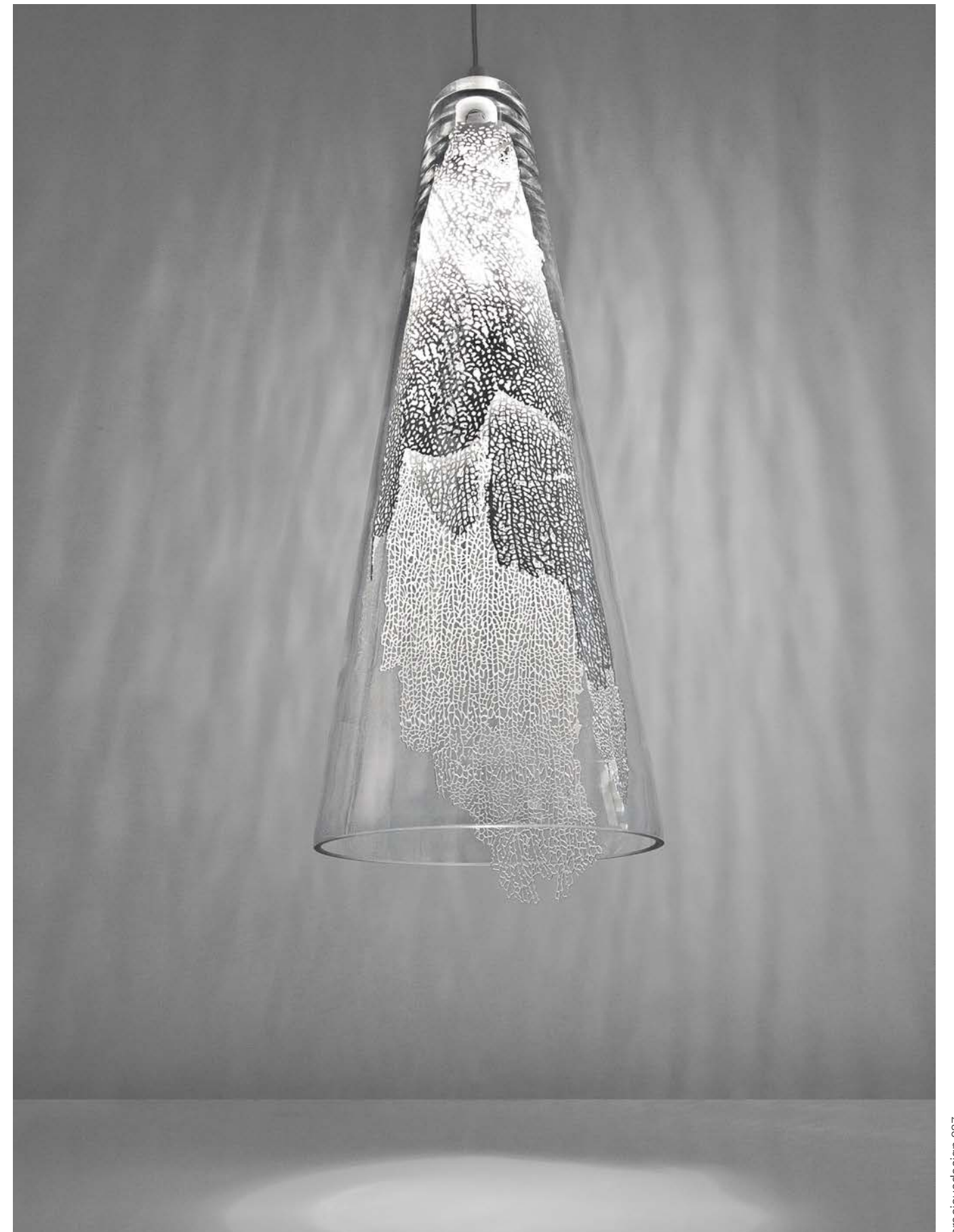

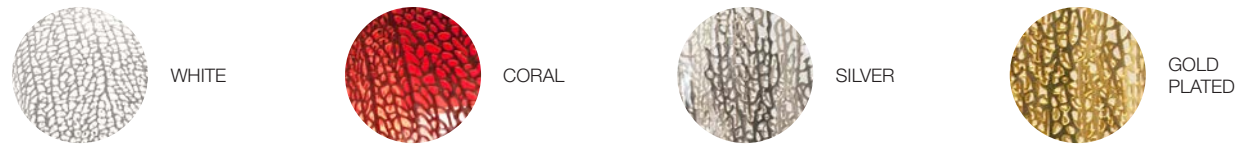
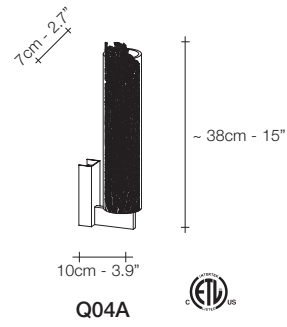
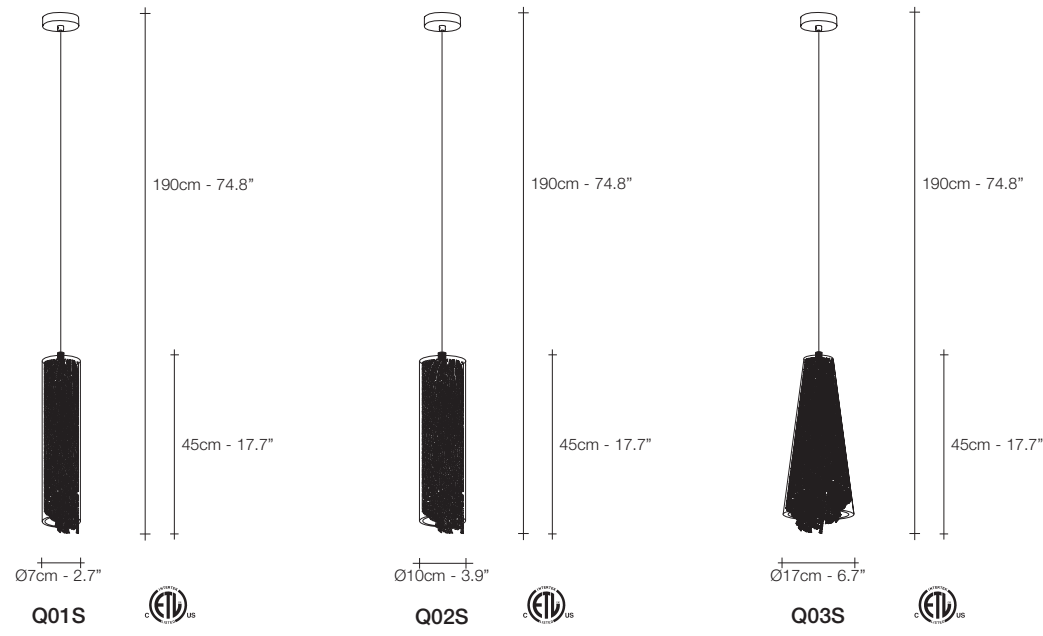

LIGHT SOURCE		Q01S	Q02S	Q03S	LIGHT SOURCE		Q04A
230V	E14 LED	4W	4W	4W	230V	G9 LED	3,5W
	Dimmable	✓	✓	✓		Dimmable	✓
120V	E12 LED	4W	4W	4W	120V	G9 LED	4W
	Dimmable	✓	✓	✓		Dimmable	✓

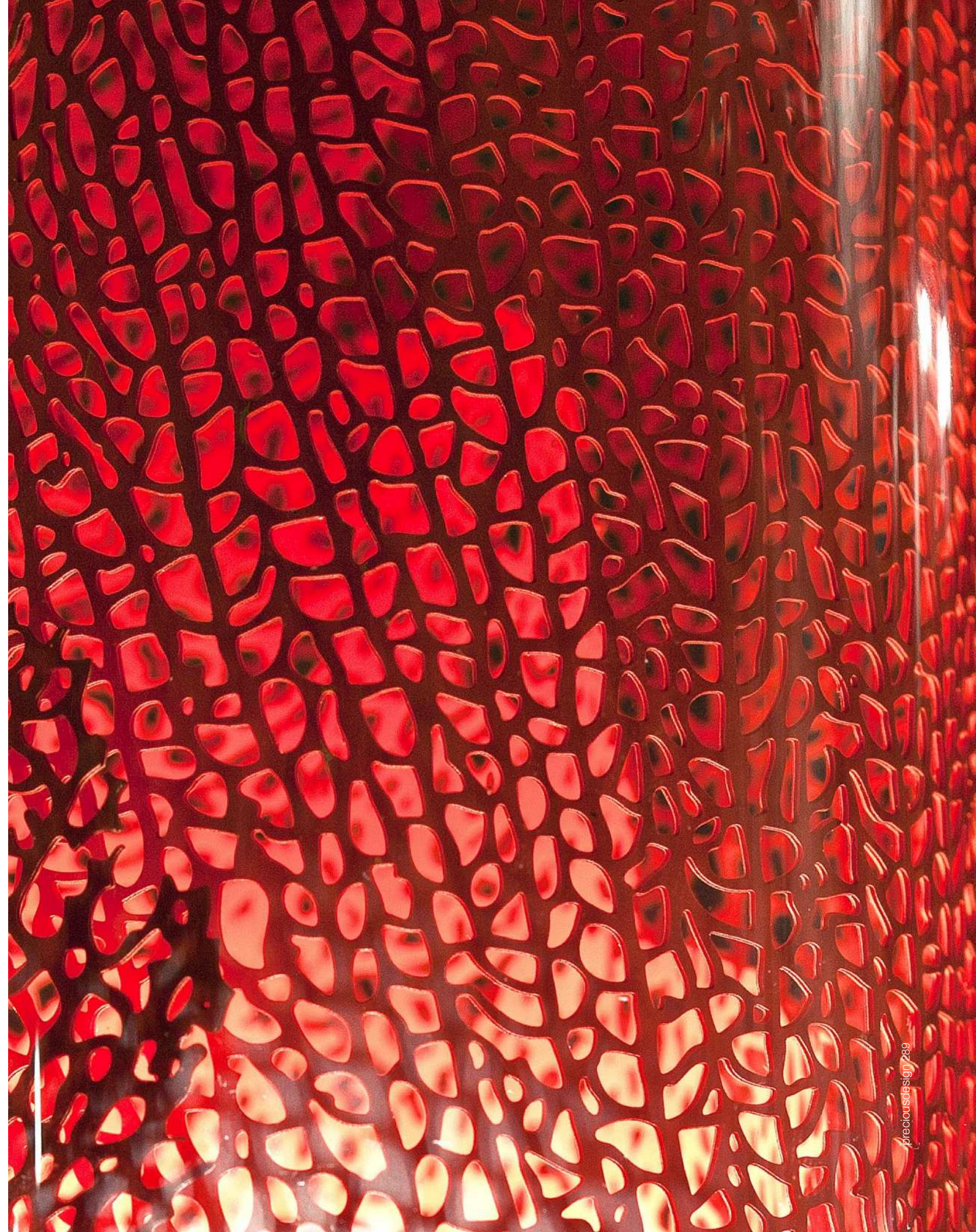

Calle, Perennial *Elegance.*

At Terzani, we spend countless days searching the globe for talented new designers, but sometimes they find us. Such is the case with the young designers Luca Martorano and Mattia Albicini who approached us with the design for Calle, a fantastic a new light we instantly fell in love with. It showcases our skill at crafting crystal to take the material to an exciting, modern place. Luca and Mattia worked with our craftsmen to create a slender inverted flute of crystal that, like the calla lily it mimics, can be grouped into stunning bouquets of light. Design Draw.









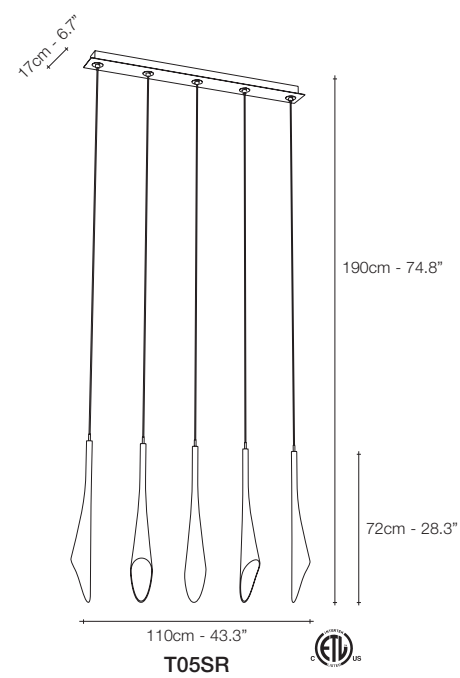
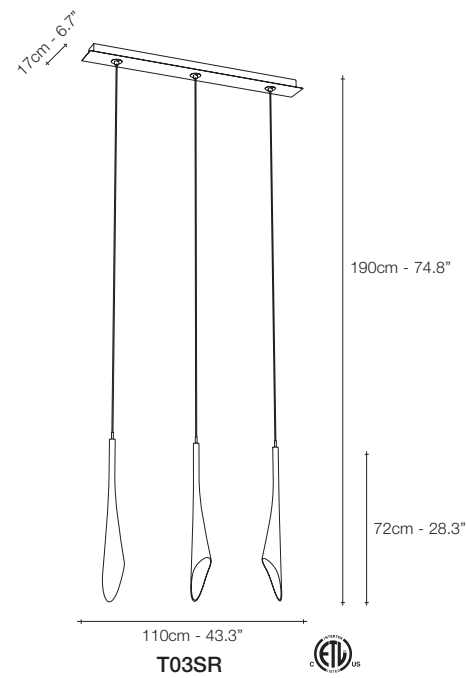
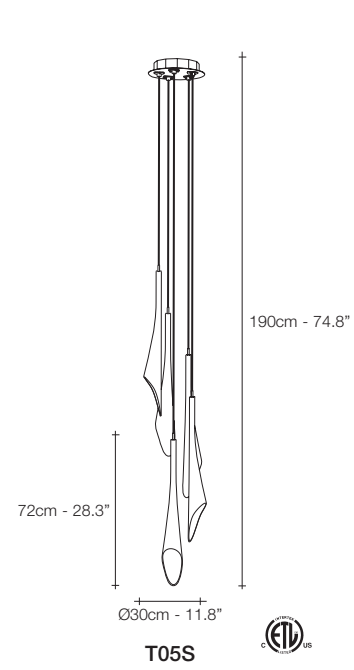
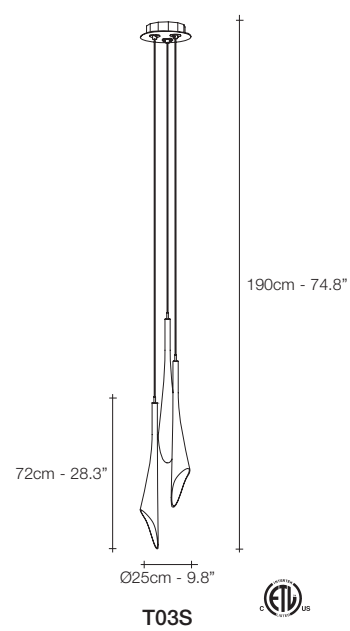
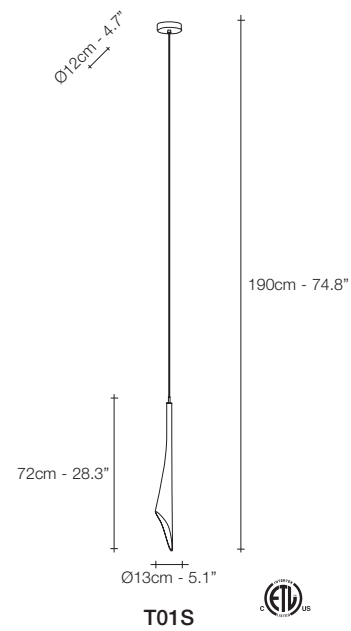
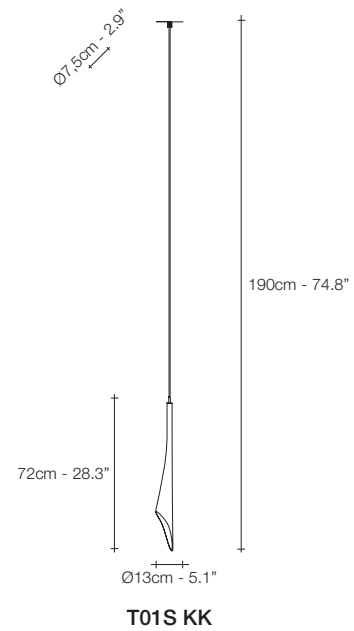

WHITE
CRYSTAL

LIGHT SOURCE OPTIONS		T01S KK	T01S	T01S	T03S	T05S	T03SR	T05SR
230V	G4 LED	2W	2W	3W	3x2W	5x2W	3x2W	5x2W
	G4 HALOGEN	20W	20W	20W	3x20W	5x20W	3x20W	5x20W
	Dimmable	IGBT 0/1-10V 10-100kΩ PUSH/DALI	IGBT TRIAC DALI	DALI	IGBT DALI	IGBT PWM DALI	IGBT DALI	IGBT 1-10V PWM DALI
120V	G4 LED	2W	2W	-	3x2W	5x2W	3x2W	5x2W
	G4 XENON	20W	20W	-	3x20W	5x20W	3x20W	5x20W
	Dimmable	ELV	ELV	-	ELV	ELV	ELV	ELV

Calle can be manufactured to work with LED light source on request, different dimming options on request



Angel Falls, Cast down *Earth.*

For his first work for Terzani, Nigel Coates, well known for his unorthodox approach to design, has created an engaging, unique light. Customizable groups of crystal “angels” are illuminated by halogen lamps. What caused these angels to fall from the heavens? It’s up to the viewers to decide. Either way, angel falls is sure to garner attention, and generate conversation, in any setting. Design Nigel Coates. Made in Italy.





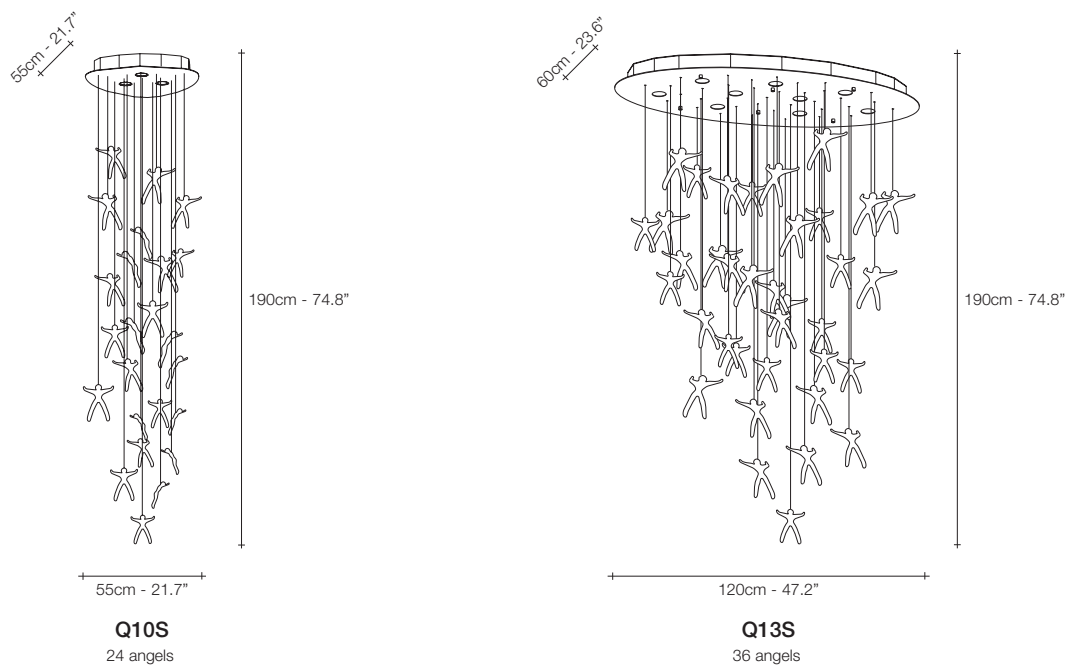
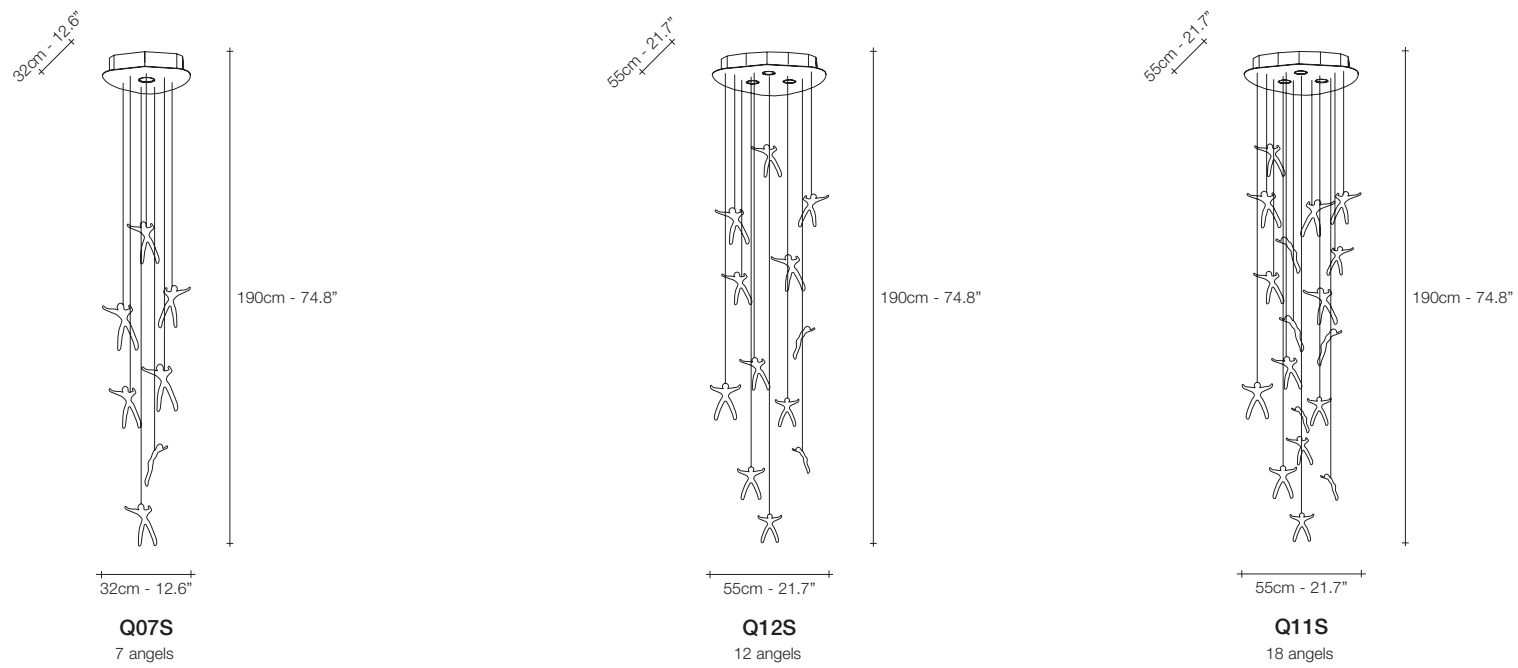

CRYSTAL

LIGHT SOURCE		Q07S	Q12S	Q11S	Q10S	Q13S
230V	GU10 LED	5W	3x5W	3x5W	3x5W	9x4W
	Dimmable	✓	✓	✓	✓	✓
120V	GU10 LED	7W	3x7W	3x7W	3x7W	9x6W
	Dimmable	✓	✓	✓	✓	✓



Anish, Playing *Spoons.*

A playful study of reflection, the idea for Anish was born when designer Dodo Arslan, while playing with his daughter, became fascinated by the almost infinite reflections spoons unleashed due to their concave and convex surfaces. Taking this idea to a larger scale, Dodo took inspiration from Italian flatware manufacturer and created a pendant composed of a range of spoons from the smallest teaspoon to serving spoons which magnifies the reflective quality of this shape. The result is an installation that creates a “galaxy” effect of seemingly endless light. Design Dodo Arslan. Made in Italy



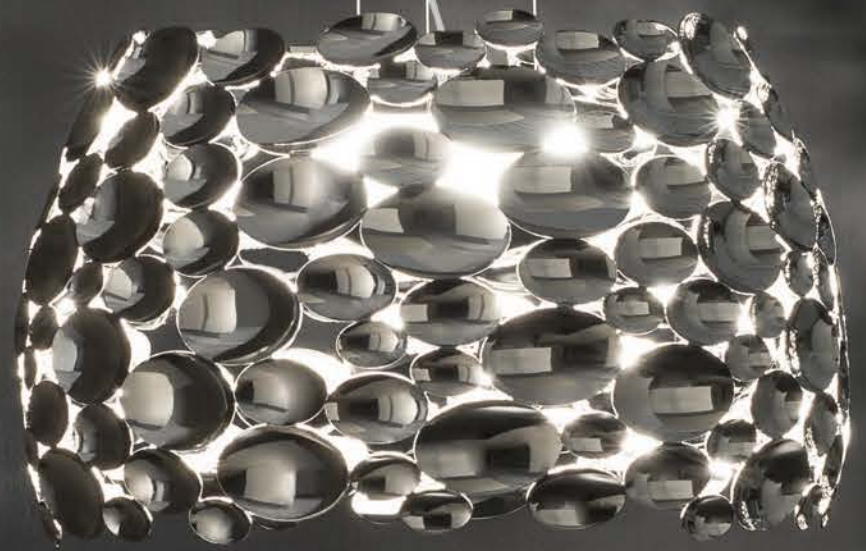

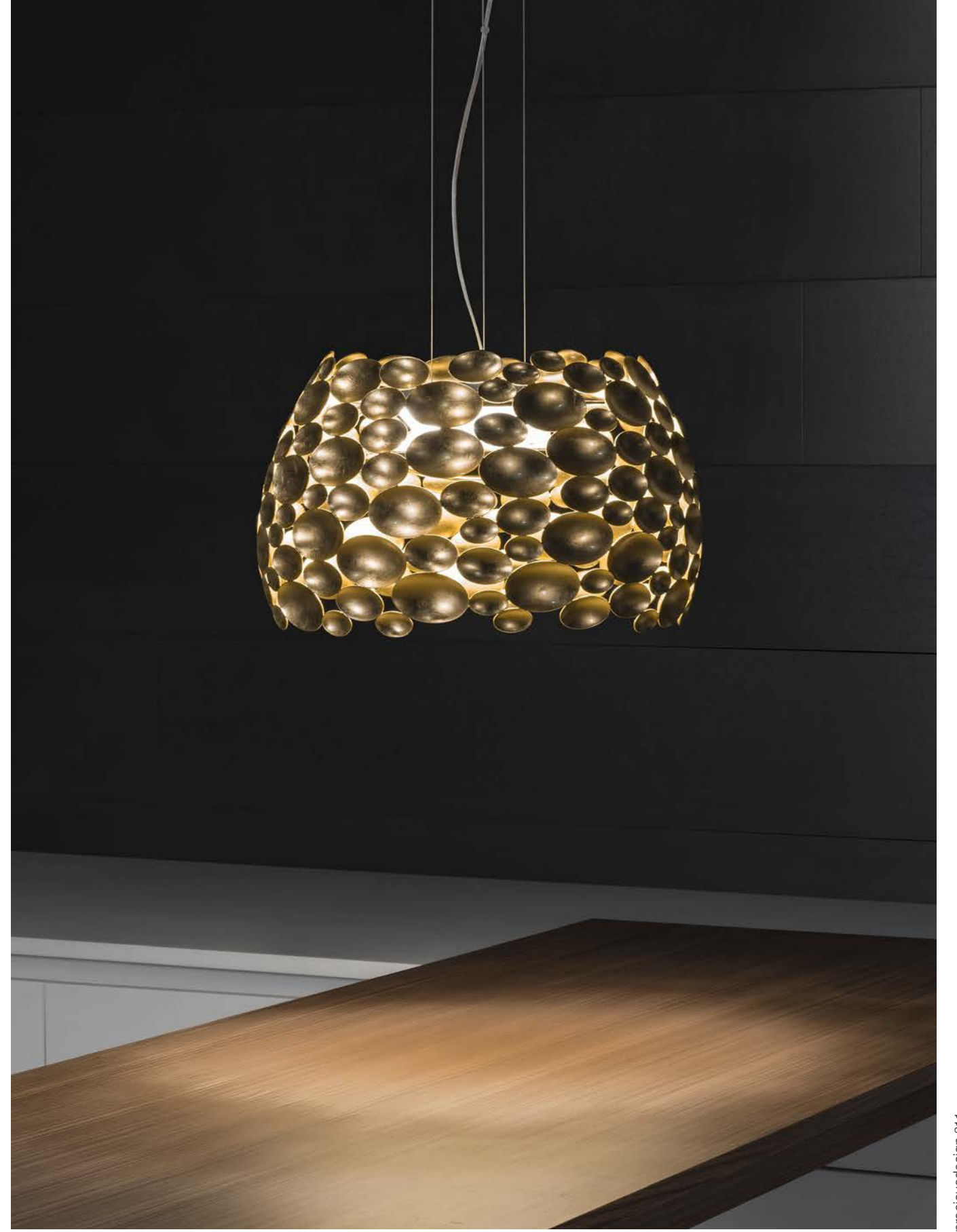
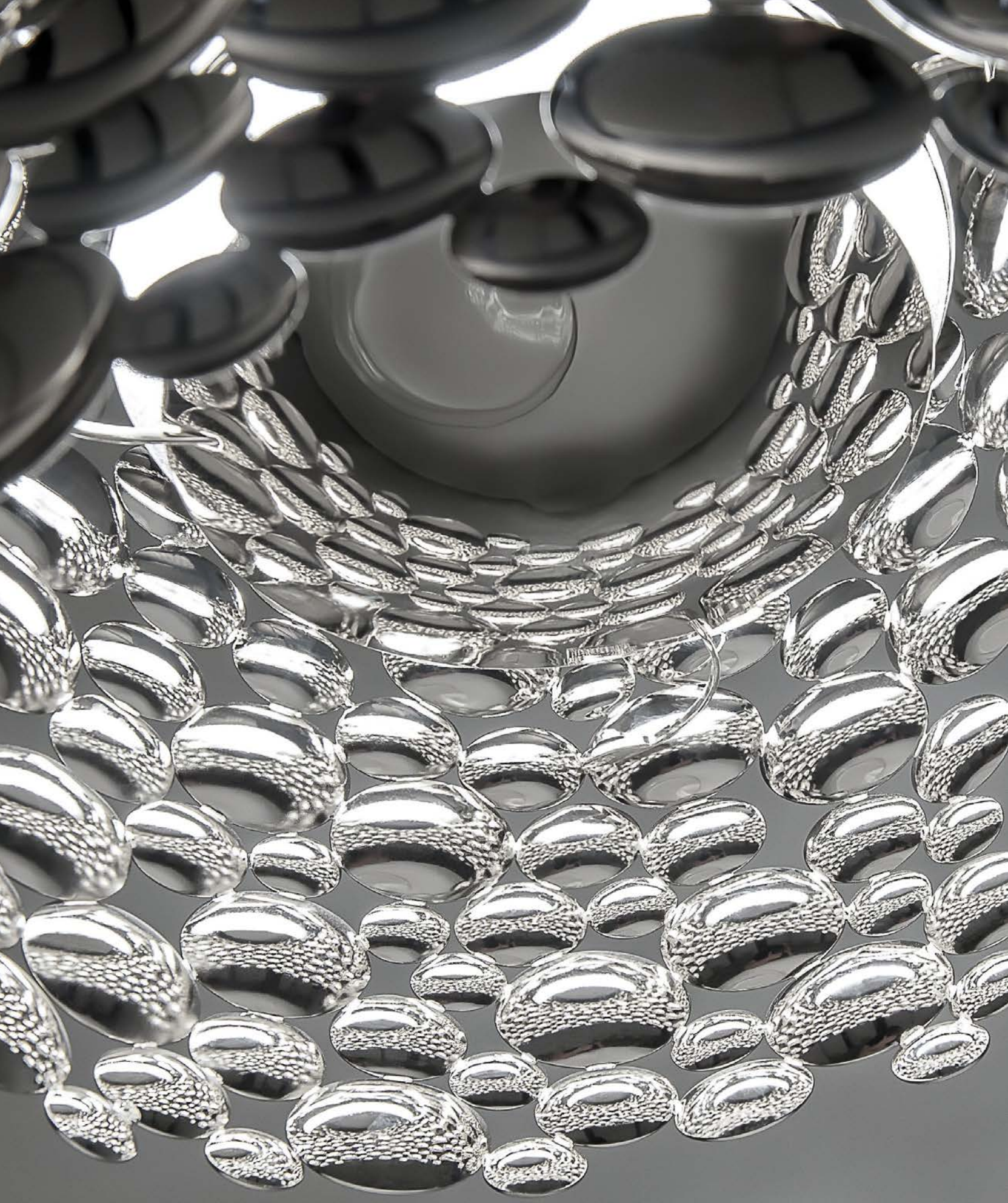

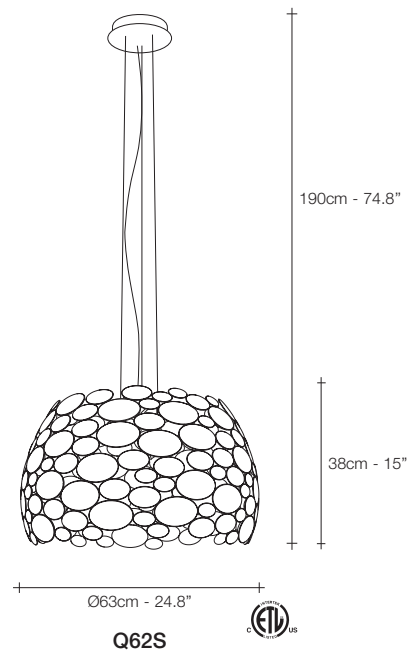
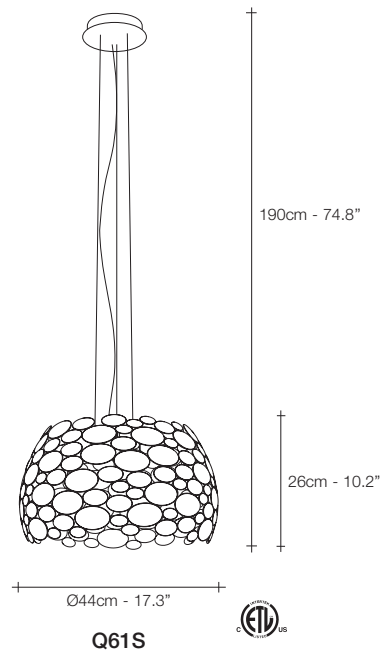

NICKEL

		Q61S	Q62S
230V	Replaceable LED module	6x4.5W	6x4.5W
	CRI 90 3000K 2700K	3970lm 3600lm	3970lm 3600lm
	Dimmable	0/1-10V PWM 10-100kΩ PUSH/DALI	0/1-10V PWM 10-100kΩ PUSH/DALI
120V	Replaceable LED module	6x4.5W	6x4.5W
	CRI 90 3000K 2700K	3970lm 3600lm	3970lm 3600lm
	Dimmable	1-10V PWM 10-100kΩ	1-10V PWM 10-100kΩ

Anish can be manufactured to work with integrated LED boards 3000K or 2700K. Different dimming options on request

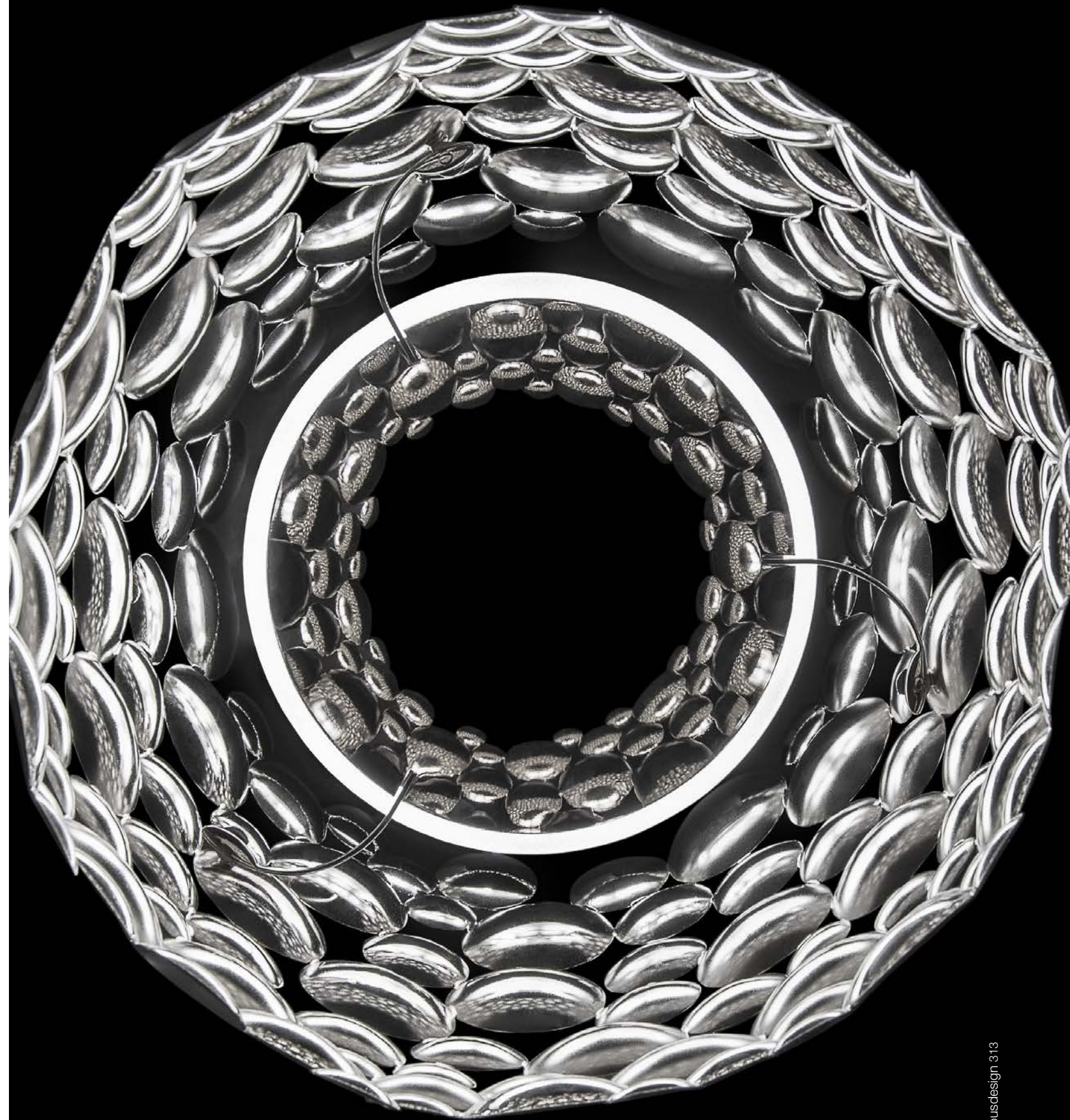

G.r.a., gyrating Romantic *rings of Light.*

This clean, precise form is the result of hours of labor by our artisans, who meticulously weld each ring together. G.r.a. is a delicate, refined pendant whose intricate shape belies its romantic glow. Available as an oval or a sphere, G.r.a. serves as an elegant, unobtrusive complement to any room. Available in nickel, gold plated and gold leaf finishes. Design Bruno Rainaldi. Made in Italy.









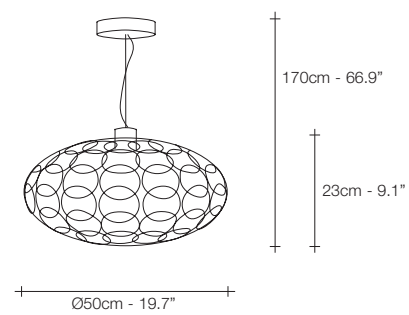

N41SL

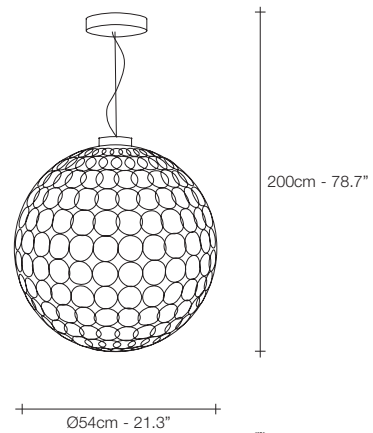

N43SL

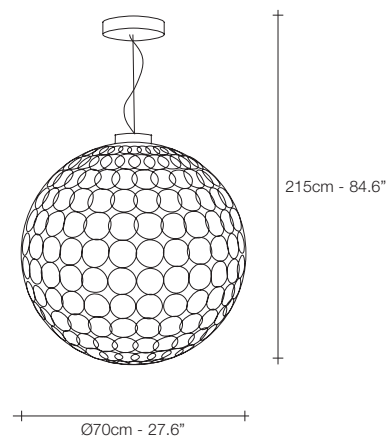

N42SL

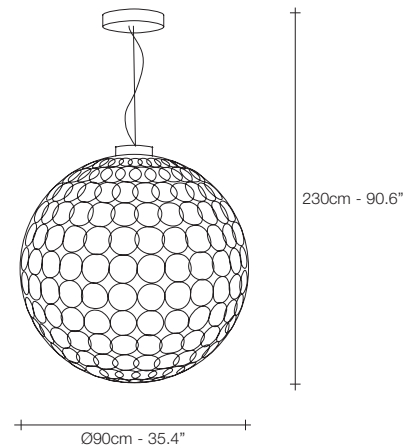

N40SL



NICKEL

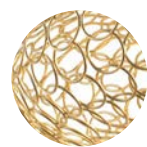

GOLD LEAF

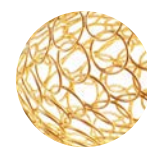

GOLD PLATED

230V	Replaceable LED module	LIGHT SOURCE			
		N41SL	N43SL	N42SL	N40SL
120V	Replaceable LED module	18W	18W	18W	18W
	LED module	1640lm	1640lm	1640lm	1640lm
	CR I 90 3000K	1570lm	1570lm	1570lm	1570lm
	2700K				
	Dimmable	1-10V PUSH/DALI	1-10V PUSH/DALI	1-10V PUSH/DALI	1-10V PUSH/DALI
	Replaceable LED module	18W	18W	18W	18W
	LED module	1640lm	1640lm	1640lm	1640lm
	CR I 90 3000K	1570lm	1570lm	1570lm	1570lm
	2700K				
	Dimmable	1-10V PUSH	1-10V PUSH	1-10V PUSH	1-10V PUSH

G.r.a. can be manufactured to work with integrated LED 3000K or 2700K. Different dimming options on request.



Orten'zia, Petals of *Light.*

Recalling the natural beauty of a flower, Orten'zia hand-soldered "petals" emanate a unique glow, immersing the entire room in a glimmering light. An organic radiance is created through light and shadow, planting a garden within the room. The orten'zia's elegant form complements its dramatic light. Available in nickel and gold plated finishes. Design Bruno Rainaldi. Made in Italy.







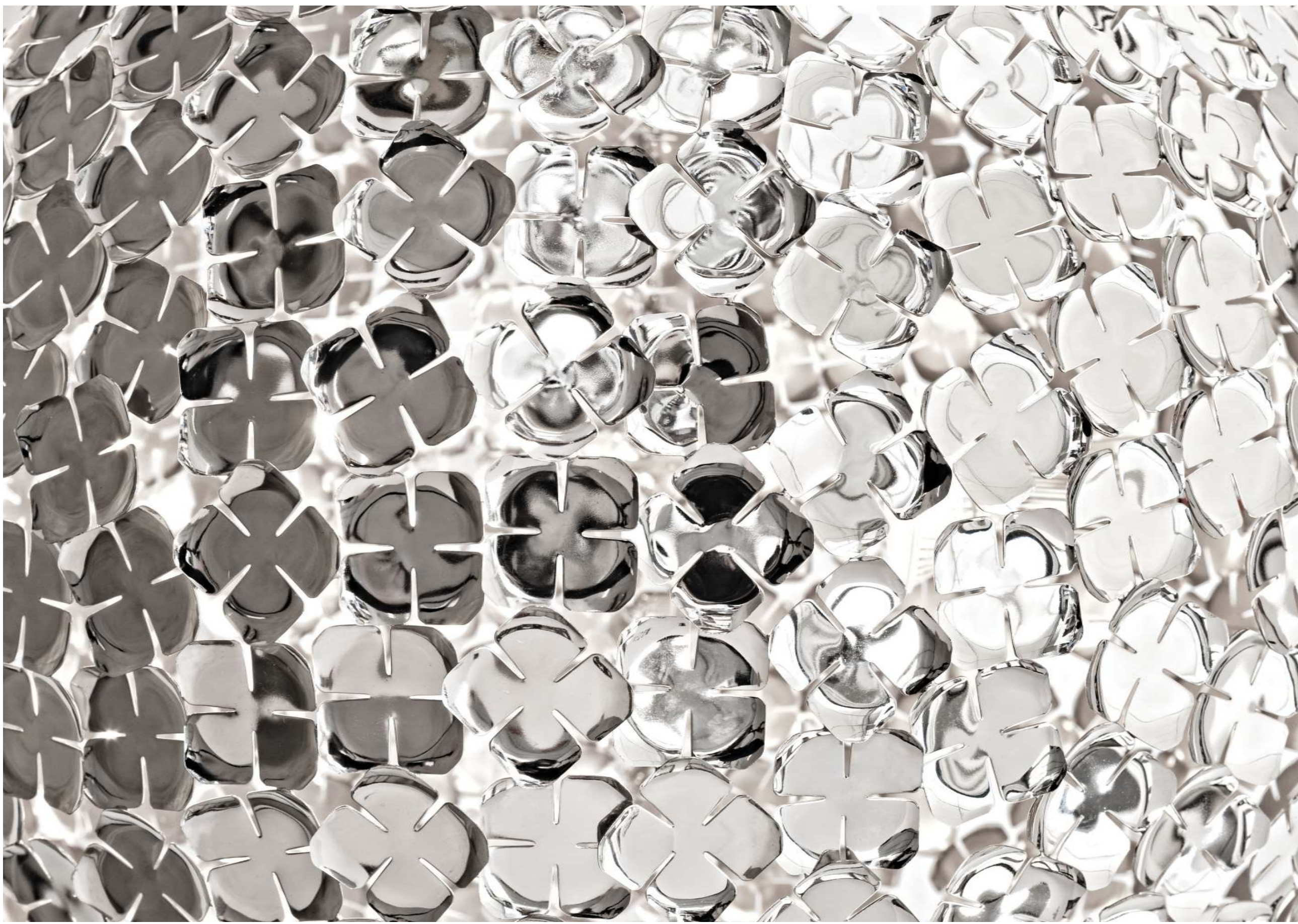



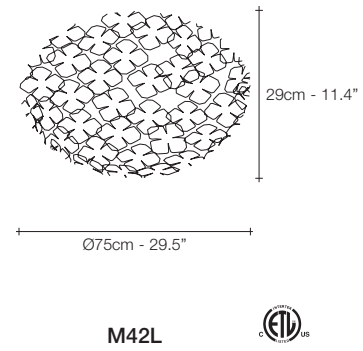
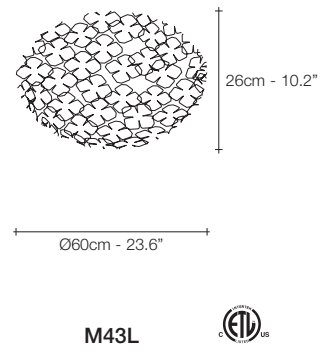
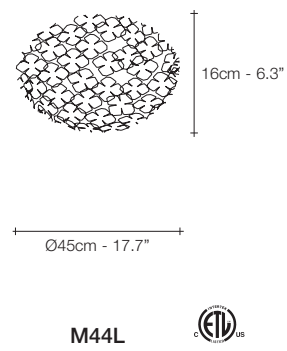
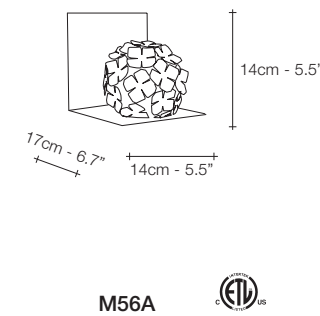
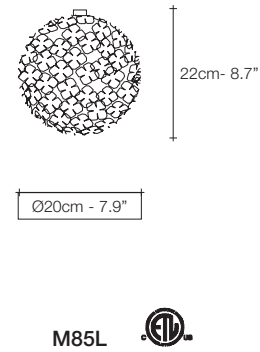
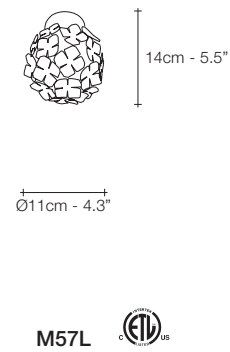
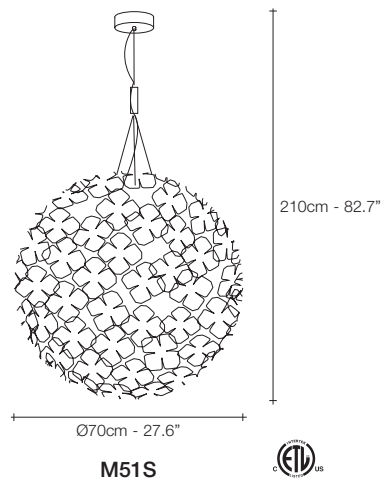
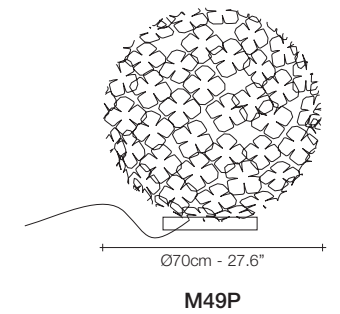
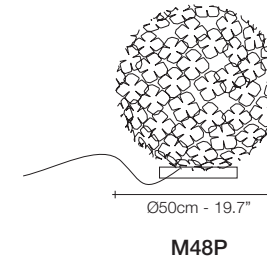
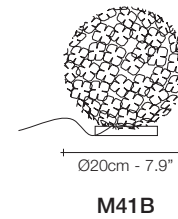
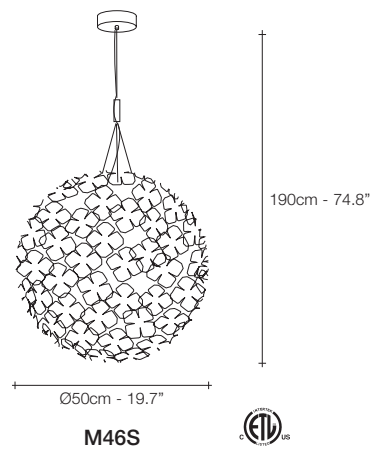
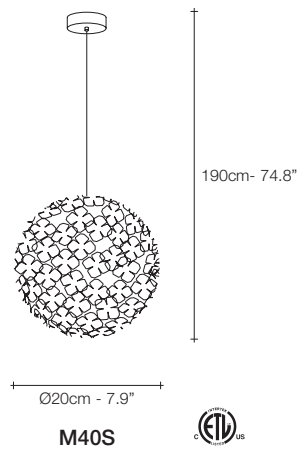
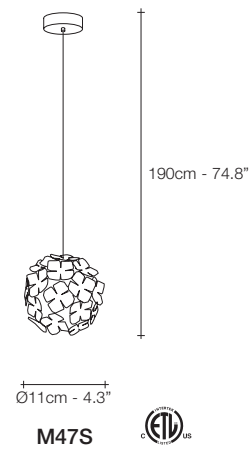

	LIGHT SOURCE	M40S	M41B	LIGHT SOURCE	M46S	M43L	M42L	M48P	M49P	LIGHT SOURCE	M44L
230V	E14 LED Dimmable	4W ✓	4W ✓	E27 LED Dimmable	15W ✓	11W ✓	15W ✓	11W ✓	15W ✓	R7s HALOGEN Dimmable	120W ✓
120V	E12 LED Dimmable	4W ✓	4W ✓	E26 LED Dimmable	15W ✓	11W ✓	15W ✓	11W ✓	15W ✓	R7s HALOGEN Dimmable	150W ✓

	LIGHT SOURCE	M47S	M57L	M85L	M56A
230V	G9 LED Dimmable	3,5W ✓	3,5W ✓	4W ✓	3,5W ✓
120V	G9 LED Dimmable	4W ✓	4W ✓	5W ✓	4W ✓

Etoile, Twinkling in an *indoor Sky.*

Etoile's intricate network of intersecting nickel lines recalls constellations in a clear night sky. Strategically placed bulbs cast a starry light, twinkling as viewers move around the pendant. Through projecting these complex patterns throughout the room, Etoile casts a heavenly glow in any space. Design Christian Lava. Made in Italy.







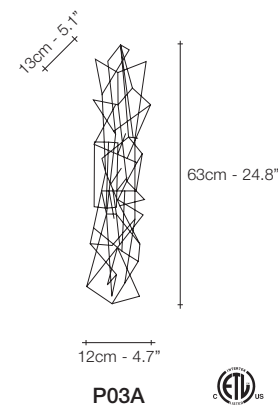
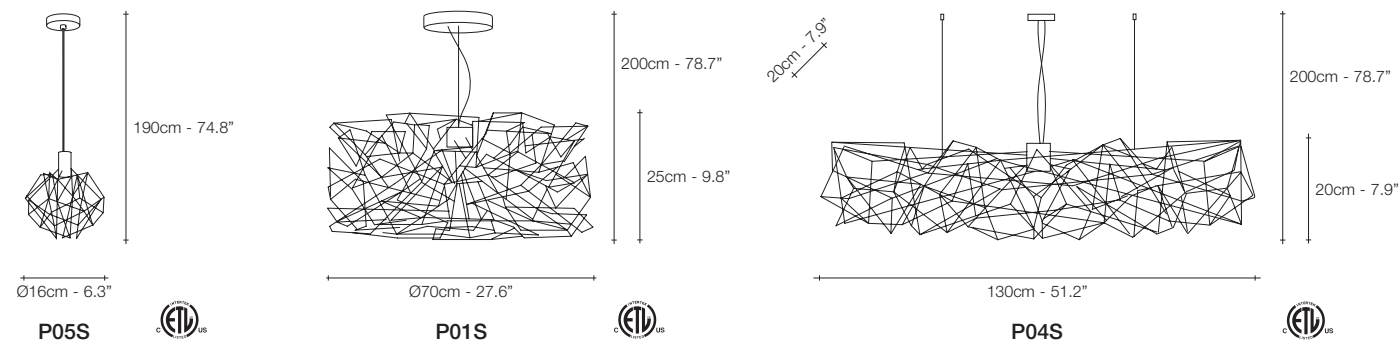

LIGHT SOURCE OPTIONS		P05S	P05S	P01S	P01S	P04S	P04S	P03A
230V	G4 HALOGEN	2W	3W	8x10W	16x1,2W	8x20W	8x2W	6x10W
	G4 LED	20W	10W	8x20W	10-100kΩ	8x2W	8x2W	6x2W
	Dimmable	IGBT TRIAC	DALI	IGBT TRIAC	0/1-10V PWM 10-100kΩ PUSH/DALI	0/1-10V IGBT TRIAC	10-100kΩ PUSH/DALI	IGBT
120V	G4 XENON	20W	-	8x10W	-	8x20W	6x10W	6x10W
	G4 LED	2W	-	8x20W	-	8x2W	6x2W	6x2W
	Dimmable	ELV	-	IGBT	-	IGBT TRIAC	ELV	ELV

Etoile can be manufactured to work with LED light source on request, different dimming options on request



Tresor, a Wealth *of Light.*

An impeccable addition to any space, Tresor's hand-made design and precious metal "coins" create scintillating halos of light. Recalling discovered treasure, the layers of gold or silver leaf create a rich, luxurious light. Available in a range of sizes, including wall sconces and pendants, Tresor has an elegance that is truly priceless. Available in silver and gold leaf finishes. Design Jean François Crochet. Made in Italy.





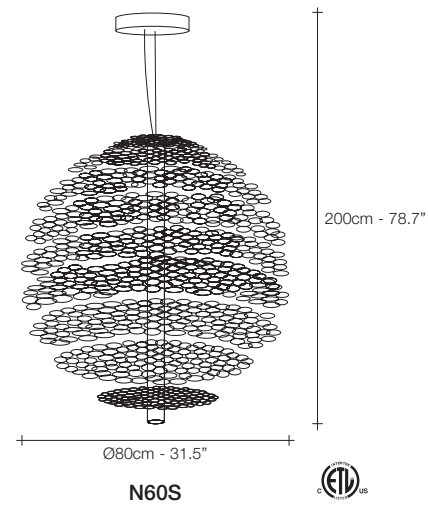

N60S

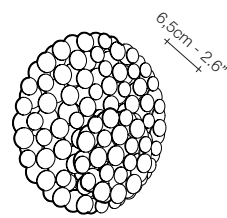

N62A

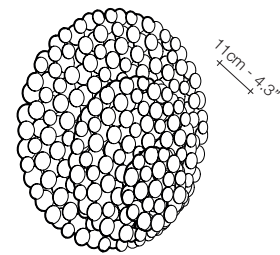

N63A

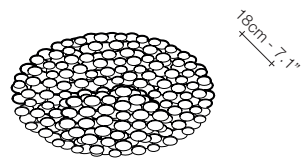

N66L

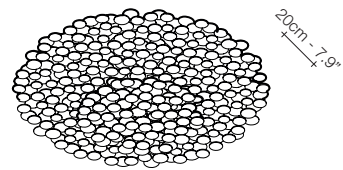

N65L



GOLD LEAF



SILVER LEAF

LIGHT SOURCE		N60S	N62A	N63A	N66L	N65L
230V	G9 LED	9x3,5W	4W	2x4W	6x3,5W	6x3,5W
	Dimmable	✓	✓	✓	✓	✓
120V	G9 LED	9x4W	5W	2x5W	6x4W	6x4W
	Dimmable	✓	✓	✓	✓	✓

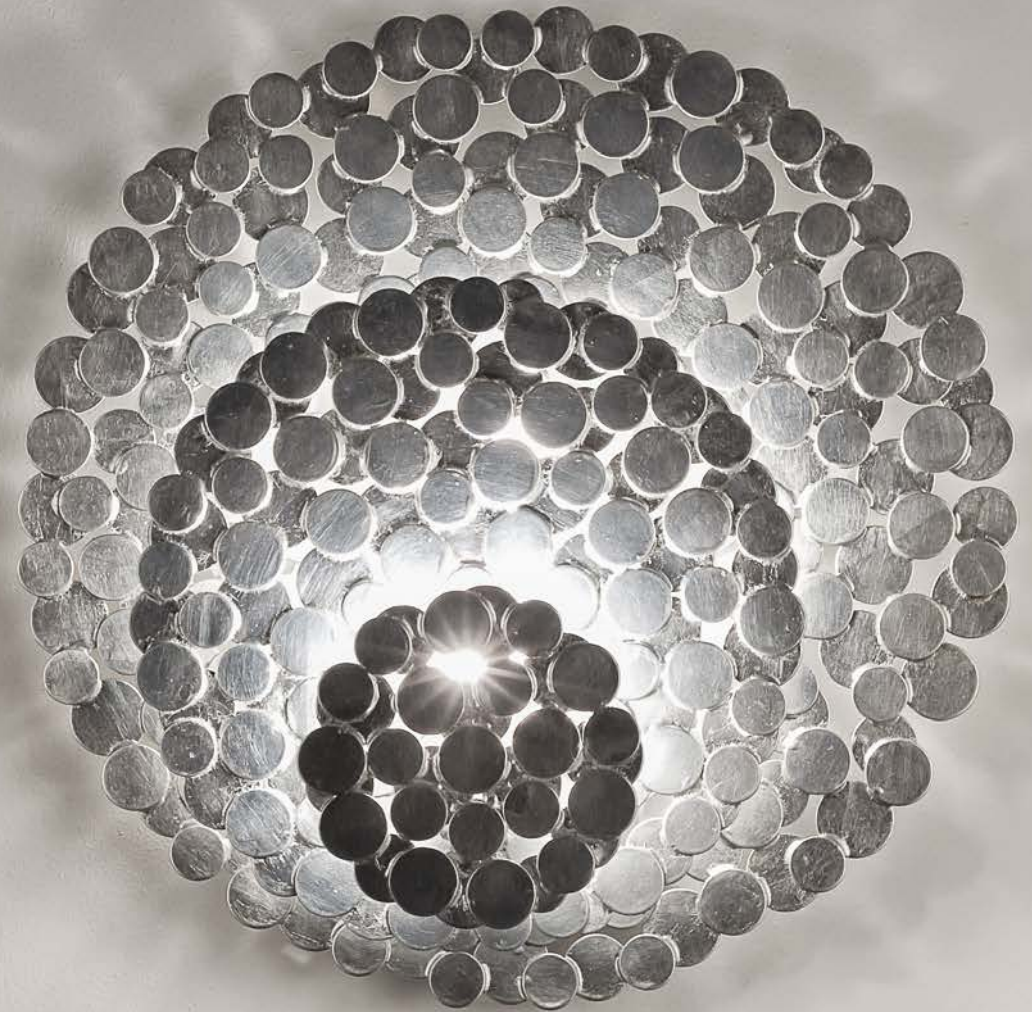

Glamour, Modern *Seduction.*

Glamour's randomly interspersed rings imbue this design with a seductiveness rarely applied to geometric shapes. Whether finished in gold plated, nickel or white, the diffused light emanating behind Glamour's rings bathes the surrounding area in a soft, sensuous glow. Available as a wall sconce, table lamp or pendant, glamour can provide subtle accents or act as the focal point of a room. Design Dodo Arslan. Made in Italy.



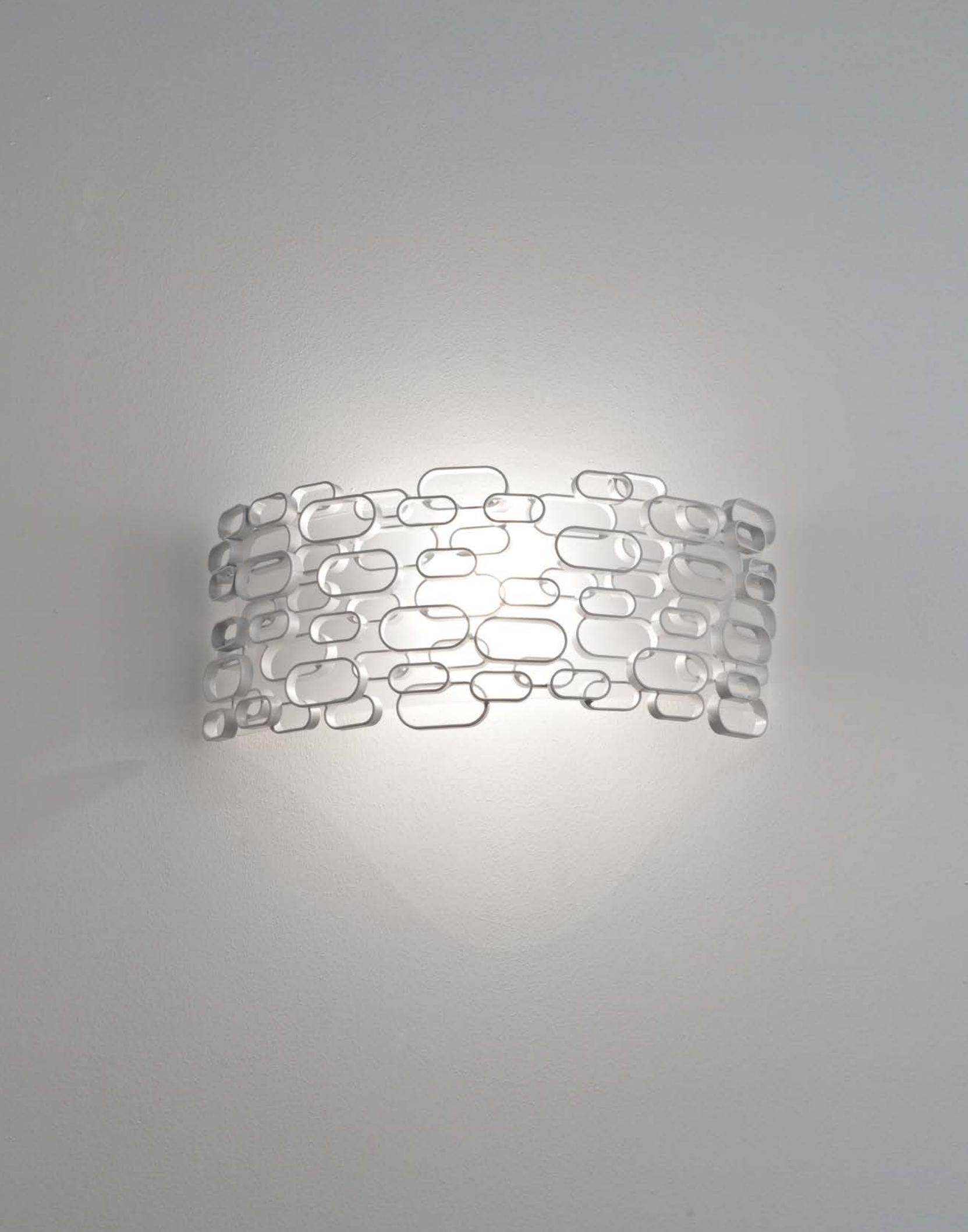



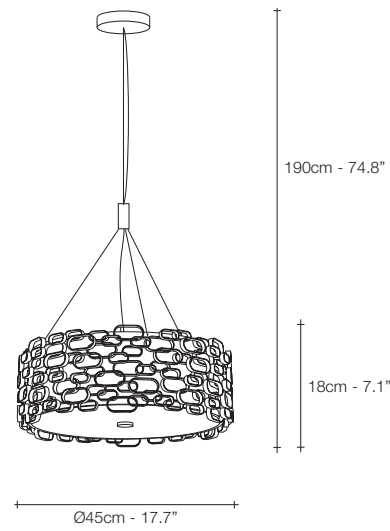

N16S 

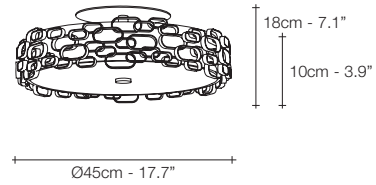

N17L 

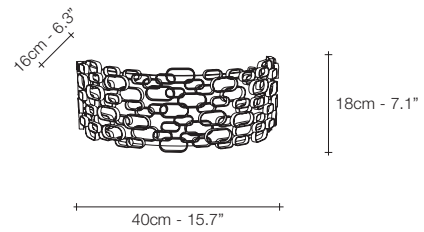

N18A 







WHITE



NICKEL



GOLD
PLATED

	LIGHT SOURCE	N16S	N17L	LIGHT SOURCE OPTIONS	N18A
230V	 E14 LED	3x4W	3x4W	 R7s HALOGEN 48W	
	Dimmable <input checked="" type="checkbox"/>	<input checked="" type="checkbox"/>	<input checked="" type="checkbox"/>	 Releaceable LED module 13W	1025lm
				Dimmable IGBT	
120V	 E12 LED	3x4W	3x4W	 R7s HALOGEN 70W	
	Dimmable <input checked="" type="checkbox"/>	<input checked="" type="checkbox"/>	<input checked="" type="checkbox"/>	Dimmable <input checked="" type="checkbox"/>	



Magdalena, Cutting edge *Beauty.*

Reaching inside traditional forms, Magdalena's laser-cut, horizontal openings allow for its light to expand its range to the entire room. Creating an alluring pattern of light and shadow, Magdalena highlights the shape of the room itself. This unique exchange creates a pendant that impacts every space, regardless of size. Available in white, semipolished nickel and gold leaf finishes. Design Bruno Rainaldi. Made in Italy.



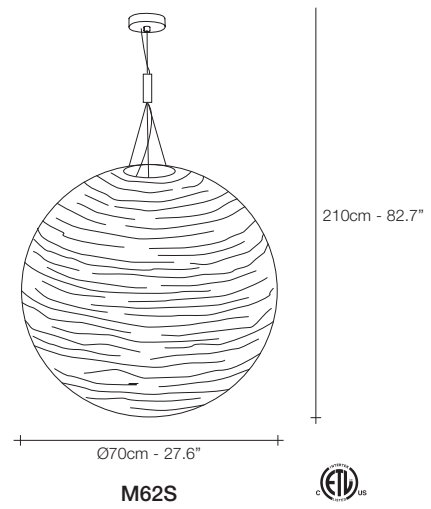
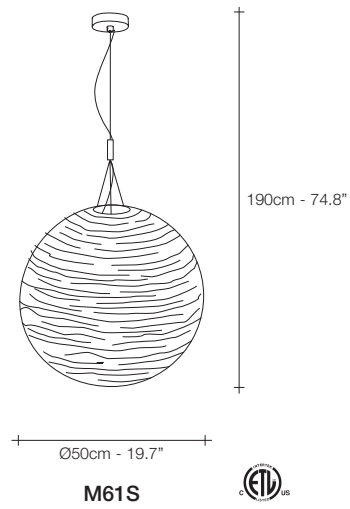
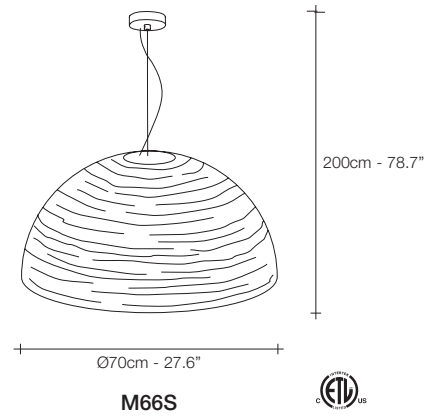
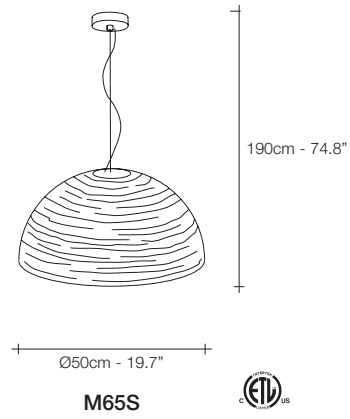

WHITE

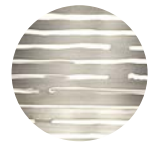

SEMIPOLISHED
NICKEL



GOLD LEAF

LIGHT SOURCE		M65S	M66S	LIGHT SOURCE		M61S	M62S
230V	E27 LED globe	15W	15W	230V	E27 LED	15W	15W
	Dimmable	✓	✓		Dimmable	✓	✓
120V	E26 LED globe	15W	15W	120V	E26 LED	15W	15W
	Dimmable	✓	✓		Dimmable	✓	✓



Hugo, a Welcome *Guest.*

Some designs are strong enough to stand alone. These are the pieces that transform spaces and inspire viewers. Hugo, a unique sculpture created by Terzani's master craftsmen, is composed of hand-forged metal stems, encasing a single light. With a graceful, delicate form, Hugo is a welcome guest in any space, intriguing and powerful. Design Jean François Crochet. Made in Italy.



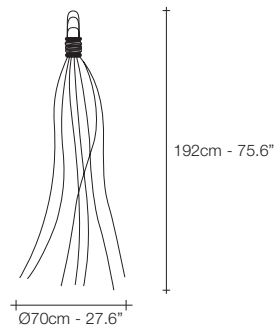

D20P

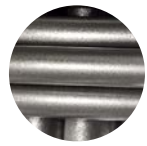

SATIN NICKEL

LIGHT SOURCE		D20P
230V	E27 LED	15W
	Dimmable	✓
120V	E26 LED	15W
	Dimmable	✓



Wabi, Understated *Elegance.*

Influenced by the rustic simplicity of the mulberry tree, Nicolas Terzani set out to create a piece that delivered the same quiet, harmonious elegance. thus, wabi, available in gold-plated or silver-plated finish, which recalls the serenity and balance of its natural inspiration. the texture of wabi harnesses the anomalies of a cortex, resulting in a unique and classic light. Design Nicolas Terzani. Made in Italy.

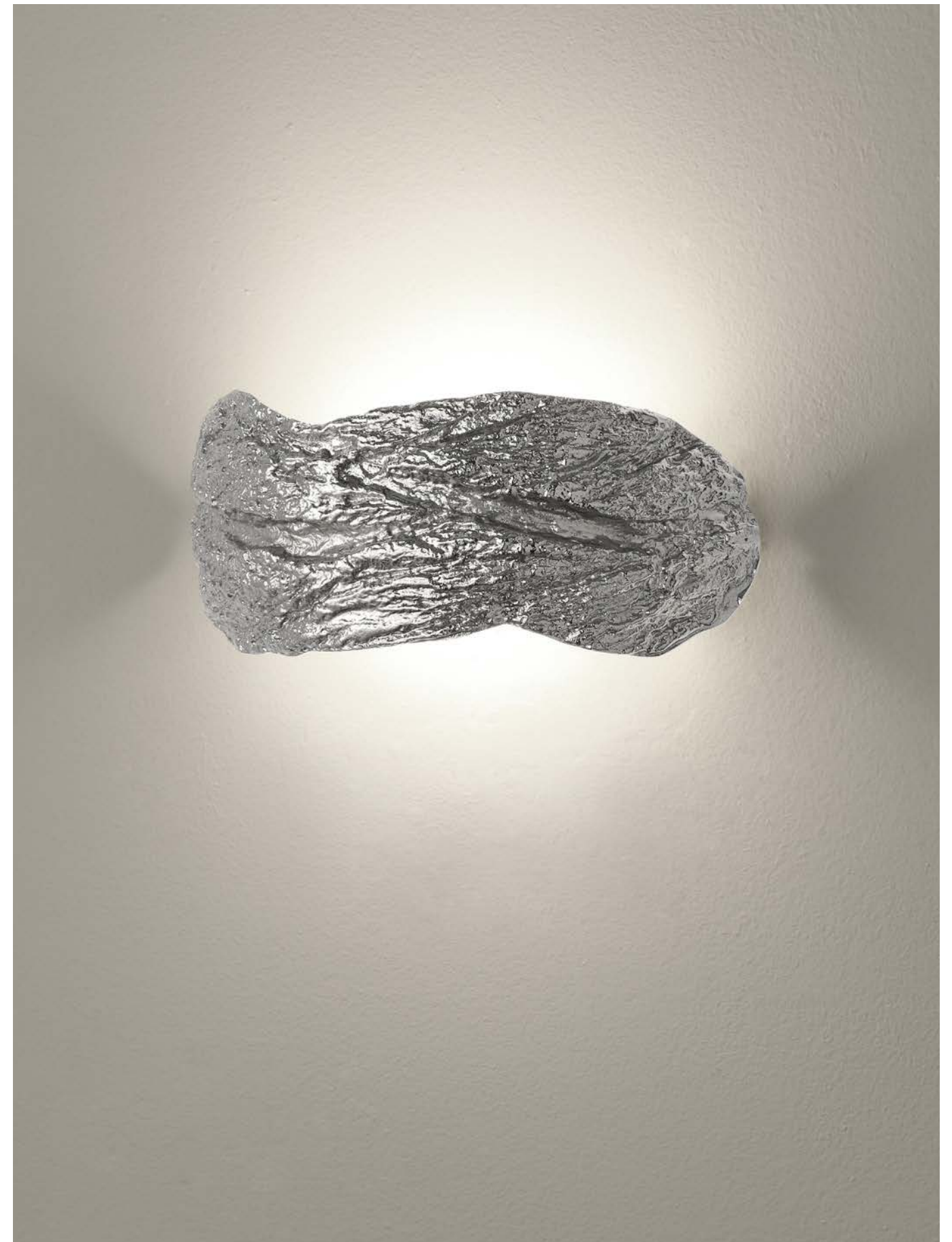

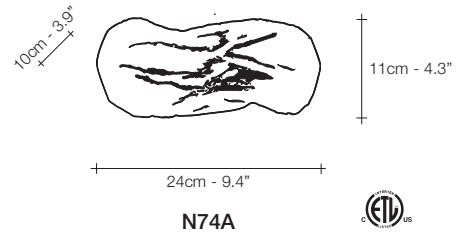

NICKEL



GOLD
PLATED

LIGHT SOURCE		N74A
230V	R7s HALOGEN	48W
	Dimmable	✓
120V	R7s HALOGEN	70W
	Dimmable	✓





Be- spoke

Work with Terzani design team to bring to life your idea. From simple modification to more complex design changes.



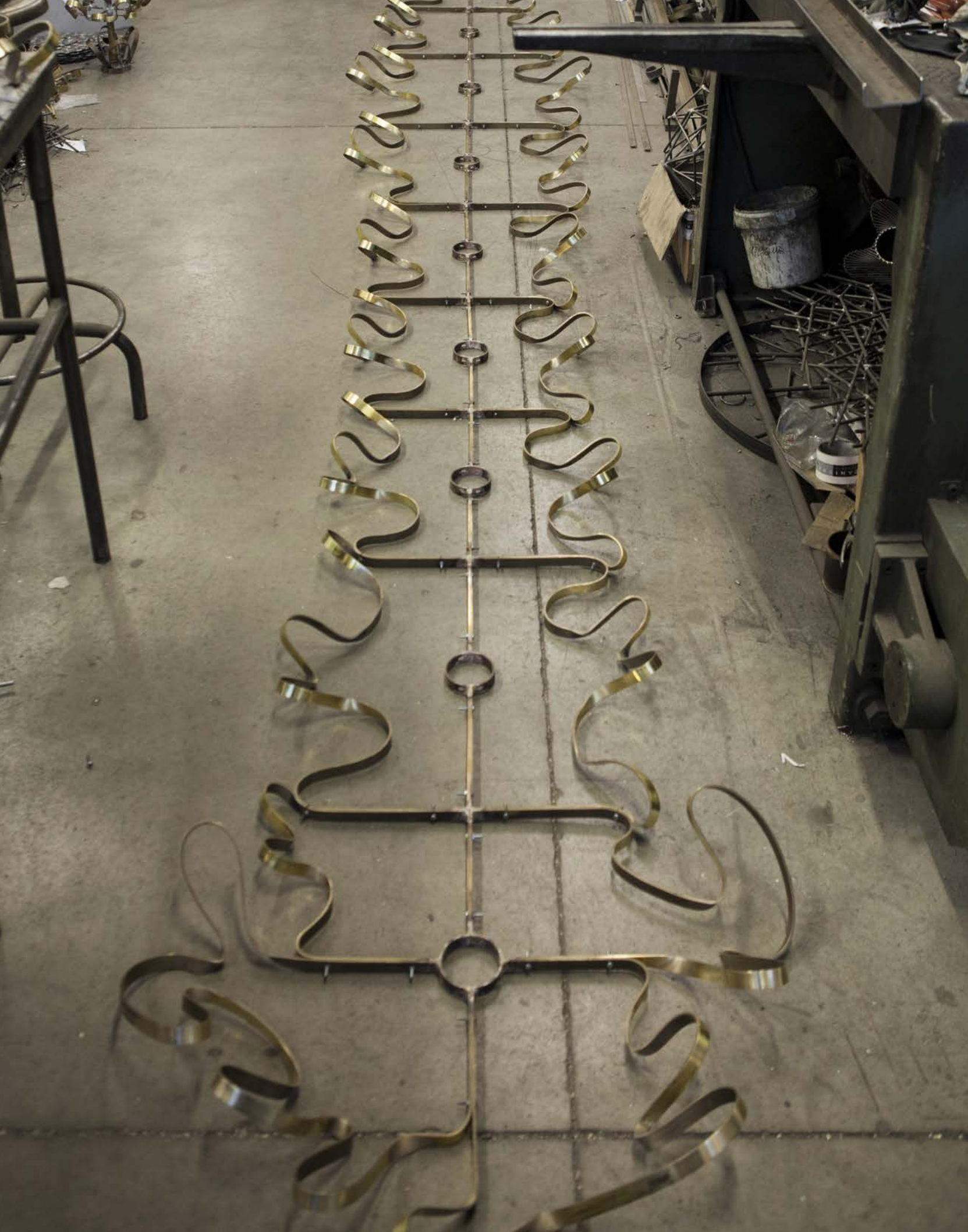

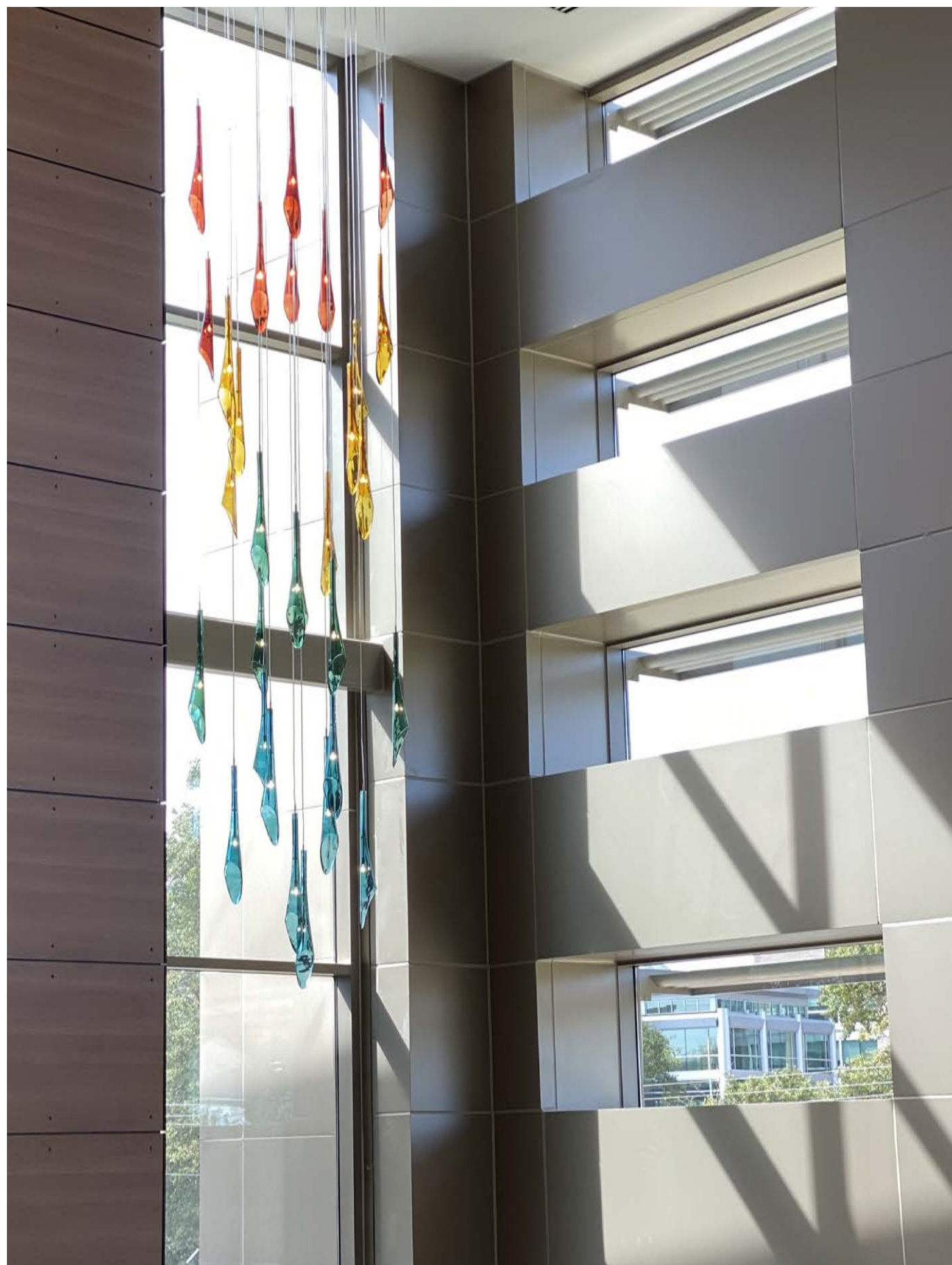

Since the beginning, Terzani has always viewed esthetics as a way of interpreting natural and artistic beauty. Born in 1972 in Florence - Italy, the cradle of the Renaissance, the company was compelled to follow the creative invocations of the city. The word "esthetics" originates from the greek "aisthesis" which means "feeling" or, more precisely, knowledge created by the use of one's senses. When you look at a Terzani design, you can sense how its light enchantingly envelops the surrounding space. It's more than simply a practical, utilitarian design it's an esthetic that represents a modern and artistic beauty through the use of design and innovative technologies.

Intersection of art, luxury and design

Terzani creations are always inspired by the dialogue between the company and the designers themselves. The pieces are born from a compelling feeling Nicolas articulates to his designers. This inspiration can be a shape that exists in nature, as you can see with the fish that inspired "I Lucci Argentati", or the stones/drops of water that inspired "Mizu", or a material or working method that attracts his attention. With the team of designers that work with the company, a project will be executed with all the necessary technical diligence, but the starting point that defines any Terzani light is always a feeling.

To create a style like what we at Terzani have established, you need to balance several characteristics. Terzani is elegant and sophisticated, innovative yet original. It uses the latest technology, but also incorporates fine materials crafted in a very artisan way. Each lamp is an object/sculpture that is meant to be fully integrated into its surroundings, spreading a charming and enchanting play of light. This creates an ever-changing dialogue between the lamp and the space around it. The feeling that Terzani exudes is one of harmony and togetherness. Its products are grounded in the human process, transmitting the handmade artisan traditions of lovingly crafting objects piece by piece. This is the essence of Terzani, which sees beauty in the contemporary world, tradition and the search for new forms and languages. Terzani continues to redefine the way luxury lighting is designed and produced. Through experimentation with new production methods and forward-thinking ideas, it has become known for designs that use sculpture, light, shadow and motion to reshape spaces.

These handmade products sit at the intersection of art, luxury and design. Following Terzani's artisan tradition, each "lighting sculpture" continues to incorporate traditional methods of processing glass and metal, along with giving individual attention to the every detail.

These designs are brought forth through the dialogue between Terzani and some of the world's most renowned designers. Terzani is proud to work with such talented artists as Dodo Arlsan, Barlas Baylar, Jean Francois Crochet, Nicolas Terzani, Nigel Coates, Maurizio Galante, Christian Lava, Studio 14, Draw, Simone Micheli, Franziska Hinze, Stefano Papi & Saviz Yaghmai, and others, to create the company's original style.

TERZANI
LA LUCE PENSATA

All products in the Terzani collections are inspired by a return to noble artisan traditions. Every object is carefully created using craft techniques and for this reason certain details may vary from product to product. These variations are not imperfections but characteristic peculiarities of the production process. Terzani reserves the right to modify its products in order to improve its features. Product reproduction on paper may result in a misrepresentation of some colors. For updated technical data please refer to our current price list or our website. For updates on e1 please visit our website or call our customer service. For e2 certification please refer to our current price list or our website. For information about Patent & Design Registration please visit: www.terzani.com/patents

Creative Direction Terzani
Art Direction Camilla Cordella
Photos Leonardo Beglieri
Digital imaging Fulvio Gallotti
Printed on FSC eco-friendly paper
Eu (Italy) 2023
© terzani 2023

Headquarters & Showroom
Terzani srl
Via Castelpulci Int.9
50018 Scandicci Firenze Italy
Office +39 055 722021
info@terzani.com

Headquarters USA & Showroom Terzani USA, Inc.
2501 SW 56th Ave
Pembroke Park FL 33023
Office 954 438 7779
Toll free 1 866 380 5412
info@terzaniusa.com

terzanishop.com
terzanishop.us
terzani.com



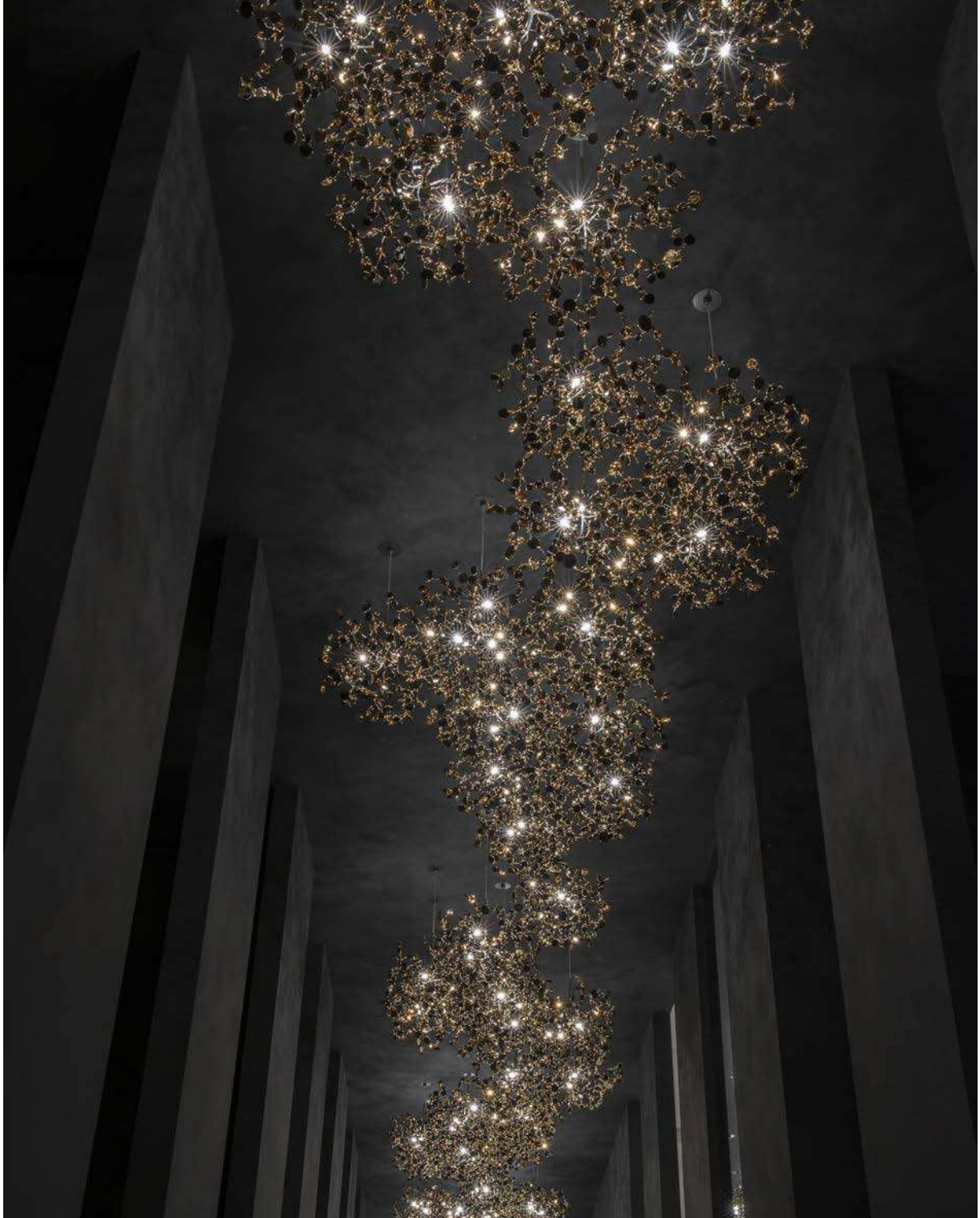

TERZANI
LA LUCE PENSATA

terzani.com